

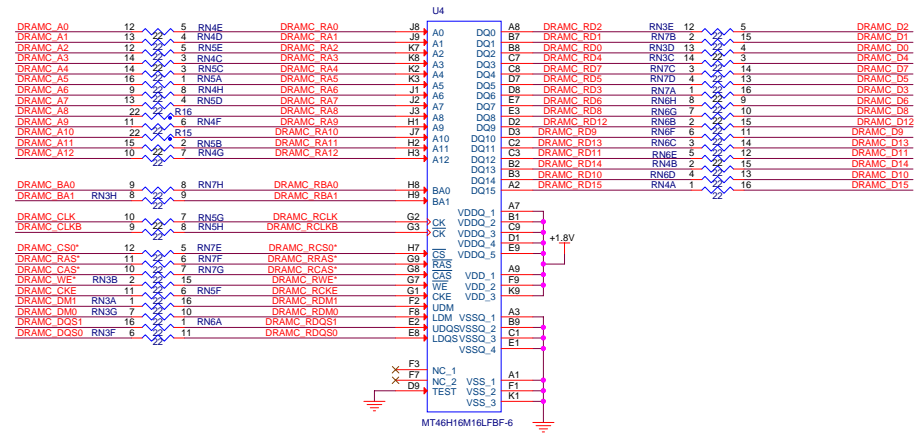

D
C
B
A

D
C
B
A



DDR

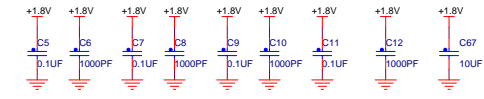

Approvals		Date	File	
Drawn	GLG	072811	TWR-PXS30 AXM-0560	
Checked	DSR	072811	Size	Document Number
Finish			C	DOC-0560-030
		Date:	Monday, April 02, 2012	Sheet 2 of 6

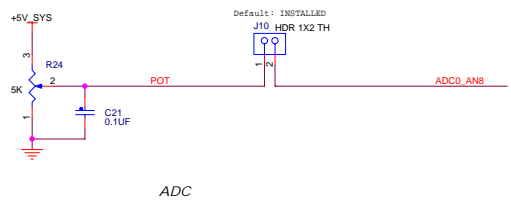
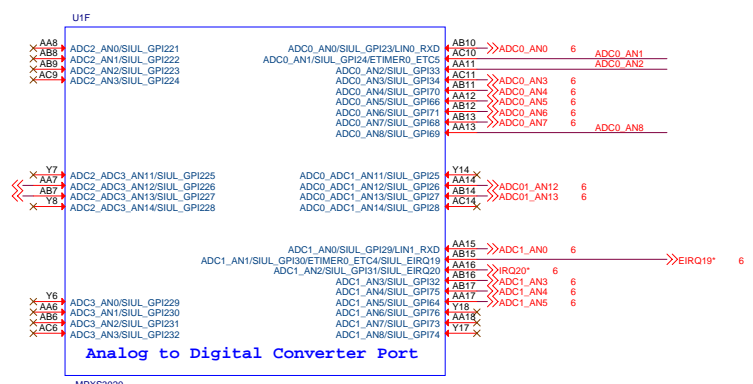
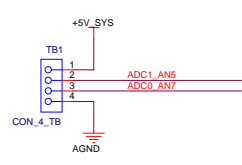
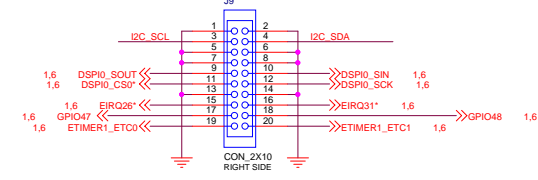
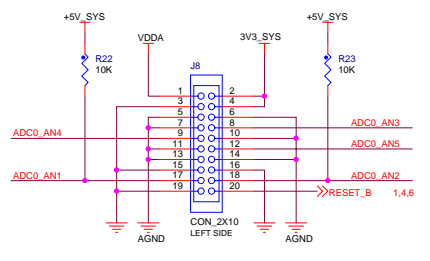
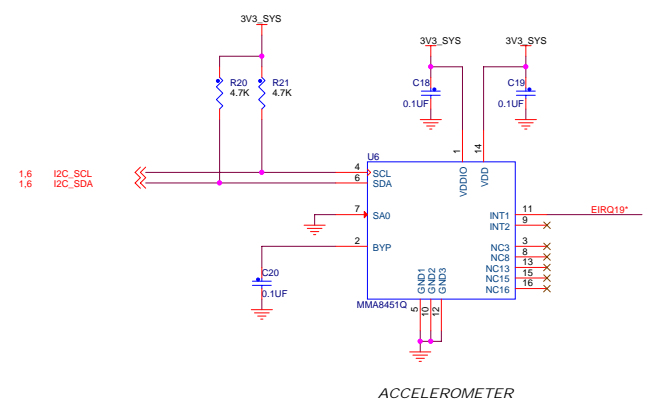
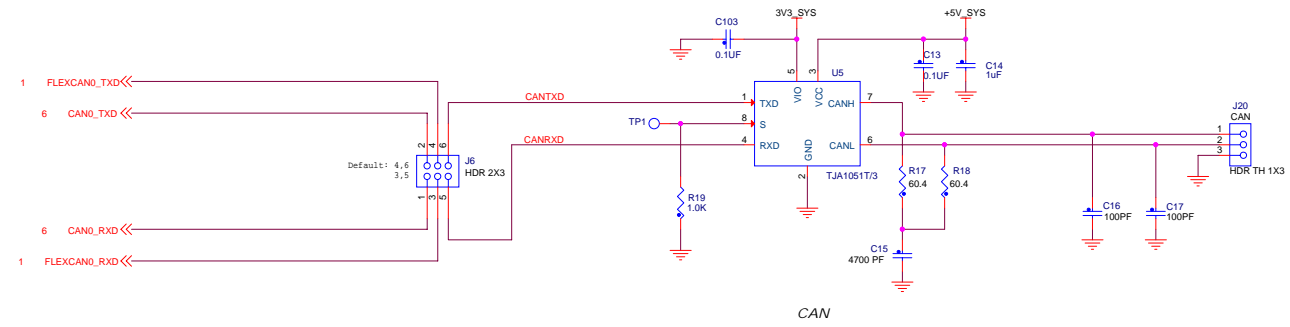

Approvals		Date	Title	
Drawn	GLG	072811	TWR-PXS30 AXM-0560	
Checked	DSR	072811	Size	Document Number
Finish			C	DOC-0560-030
Date: Monday, April 02, 2012			Sheet	3 of 6

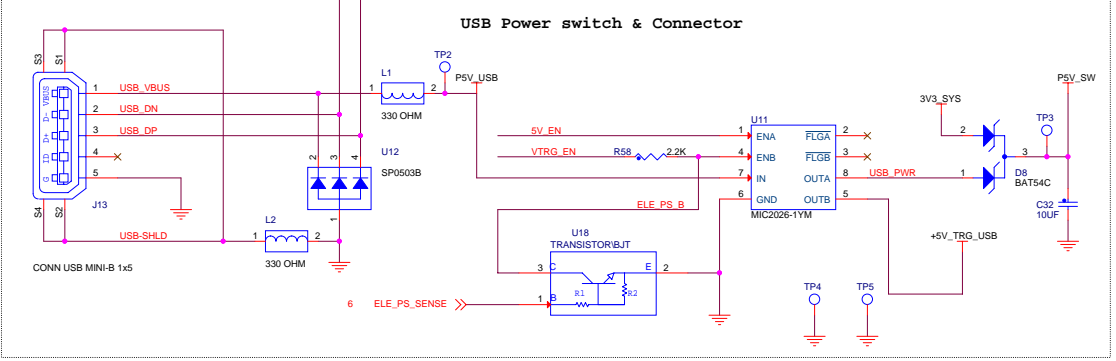
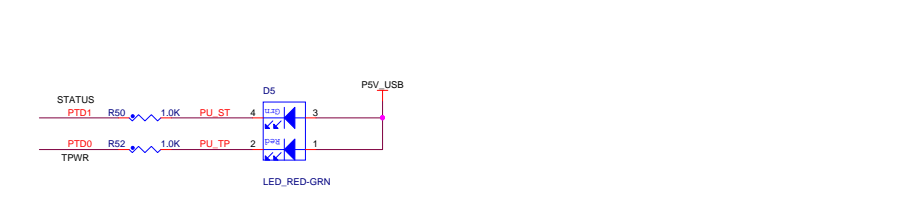
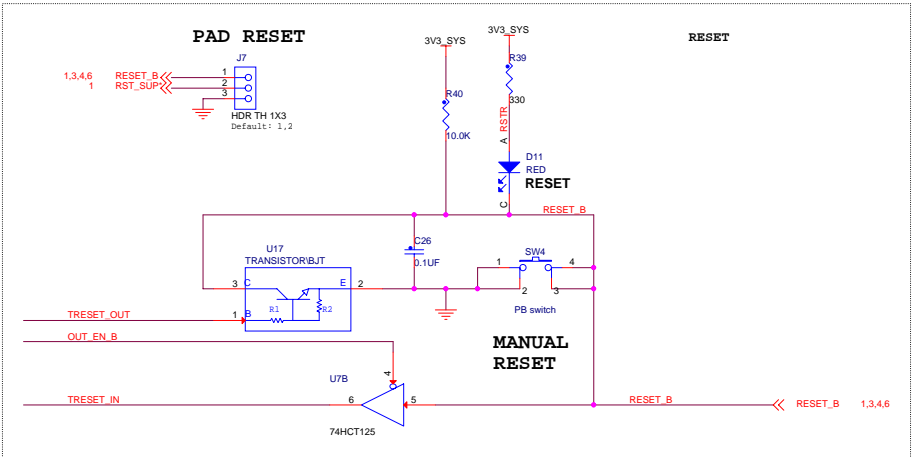
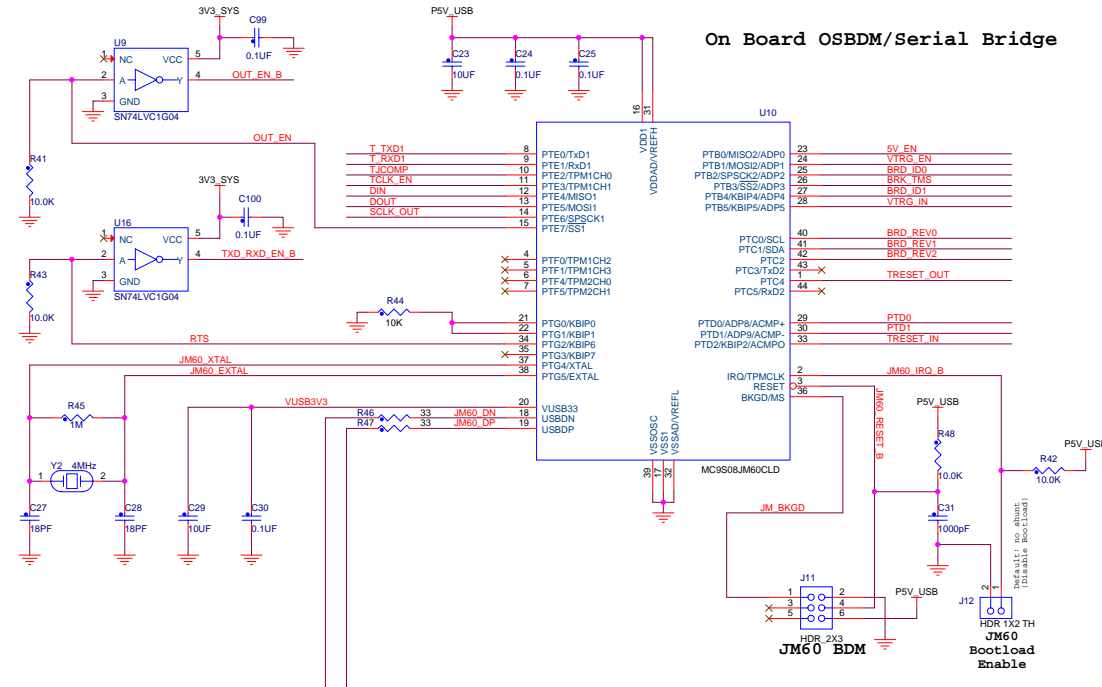
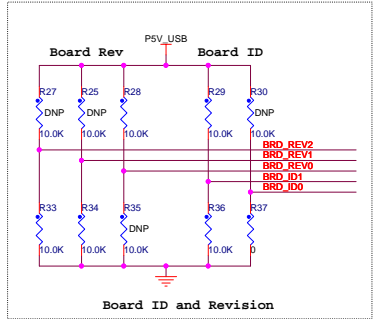
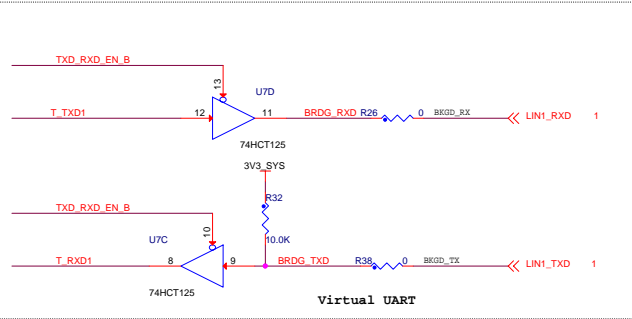
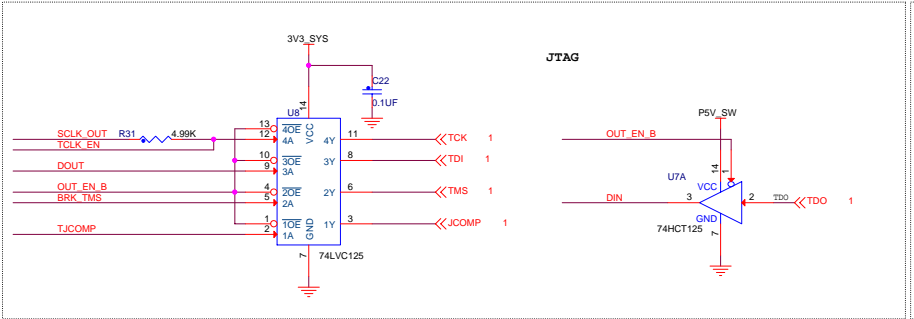

		AXIOM SYSTEMS INC.		
		Approvals Drawn Checked Finish	Date 072811	File TWR-PXS30 AXM-0560
Date: Monday, April 02, 2012		Sheet 4 of 6		

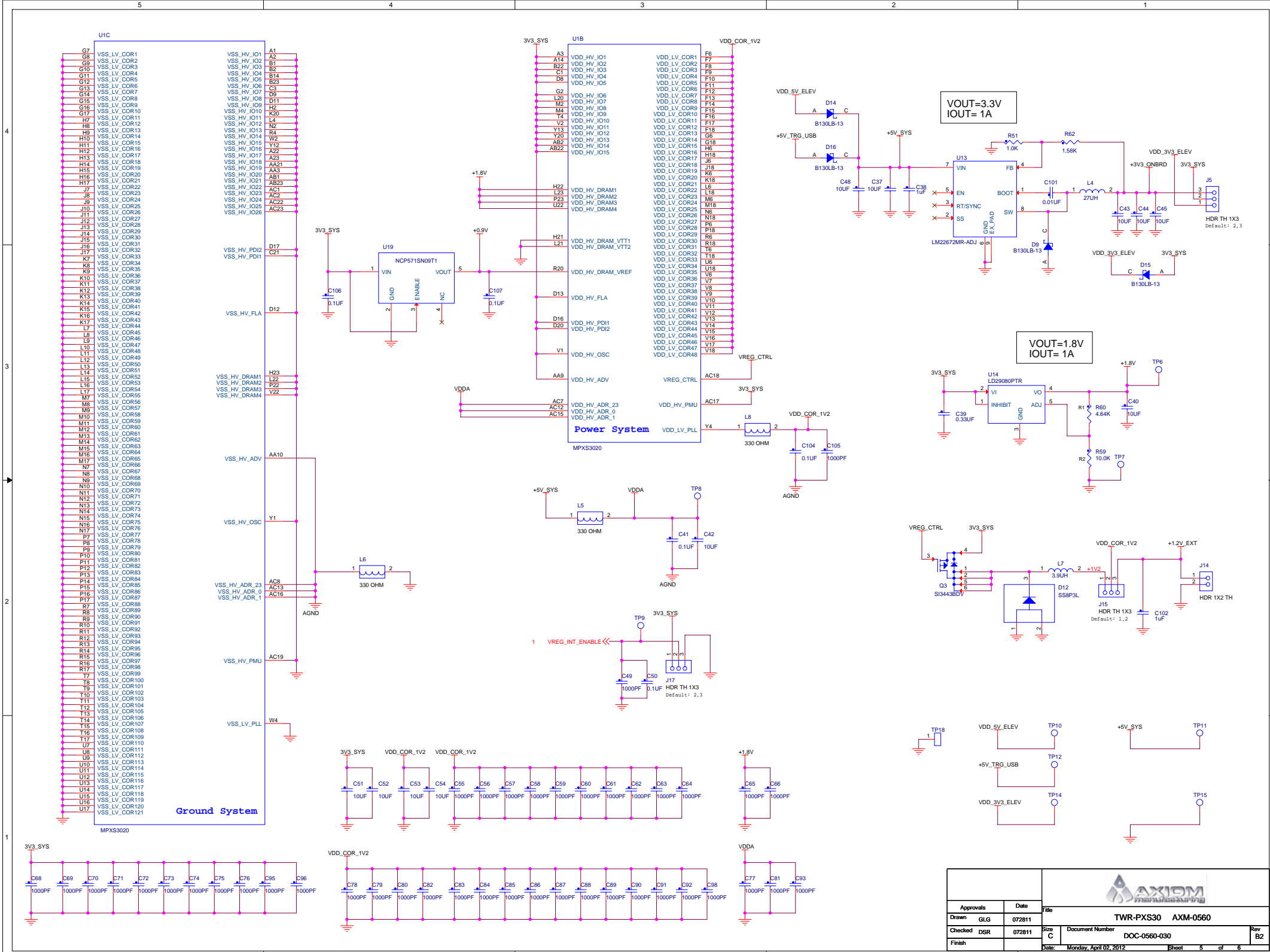

VOUT=3.3V
IOUT= 1A

VOUT=1.8V
IOUT= 1A

Approvals		Date	File	
Drawn	GLG	072811	TWR-PXS30 AXM-0560	
Checked	DSR	072811	Document Number	DOC-0560-030
Finish			Date: Monday, April 02, 2012	Sheet 5 of 6

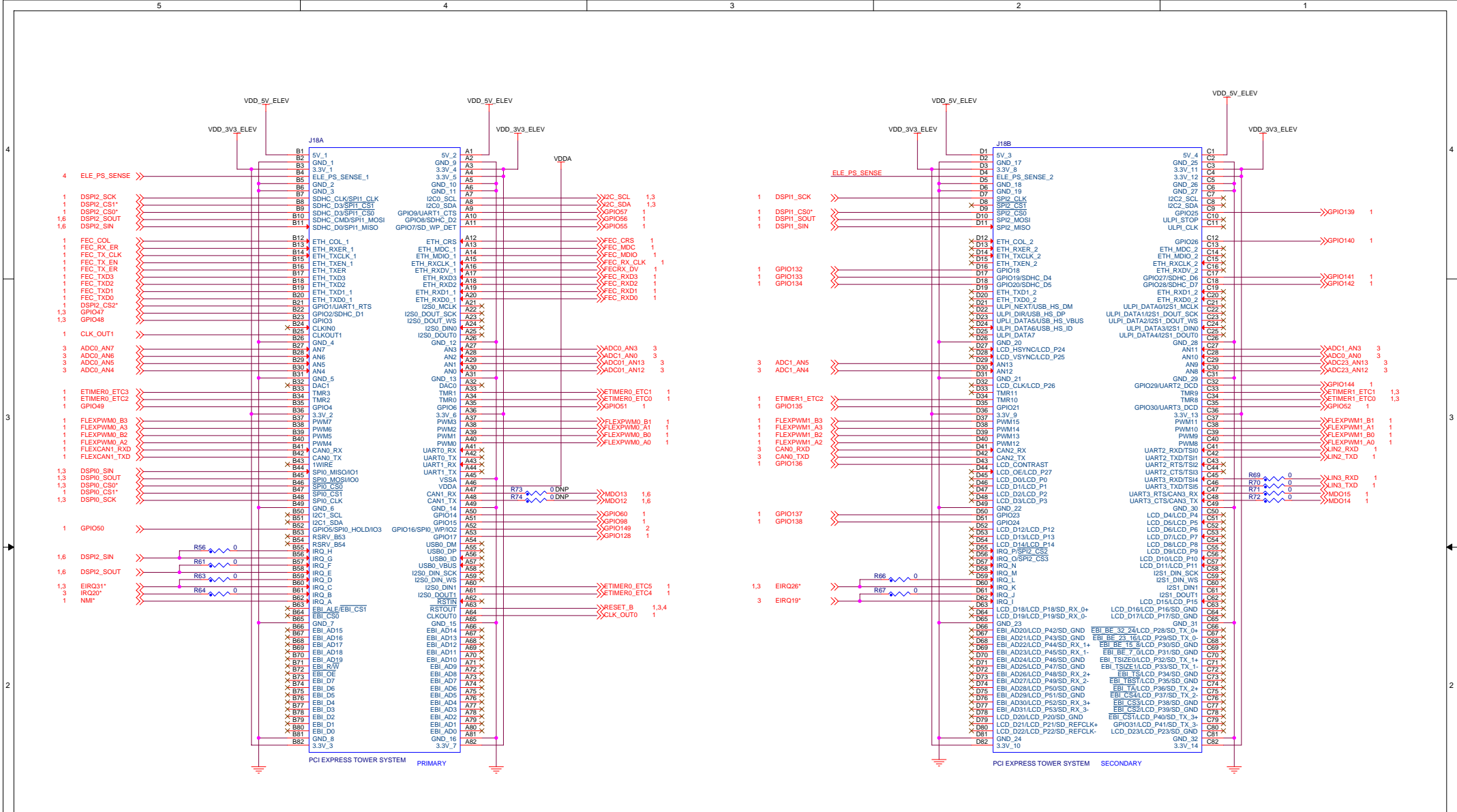

		TWR-PXS30 AXM-0560	
Approved GLG	Date 072811	File TWR-PXS30 AXM-0560	Rev B2
Checked DSR	Date 072811	Document Number DOC-0560-030	Rev B2
Finish	Date Monday, April 02, 2012	Sheet 6 of 6	Date Monday, April 02, 2012