

Approvals		Date	File	
Drawn	GLG	081611	TWR-PXS20 AXM-0559	
Checked	DSR	081611	Document Number	DOC-0559-030
Finish			Date	Monday, April 02, 2012
			Sheet	1 of 5

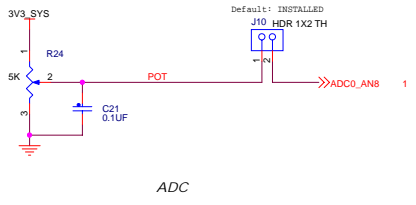

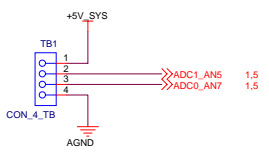

Approvals		Date	File	
Drawn	GLG	081611	TWR-PXS20 AXM-0559	
Checked	DSR	081611	Size	C
Finish			Document Number	DOC-0559-030
			Date:	Monday, April 02, 2012
			Sheet	2 of 5

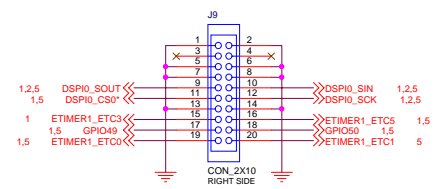
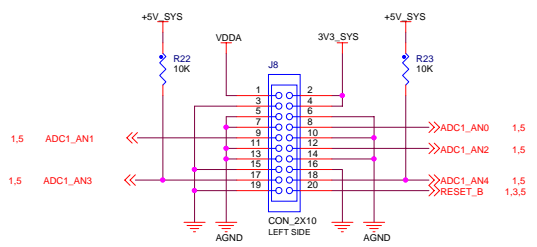
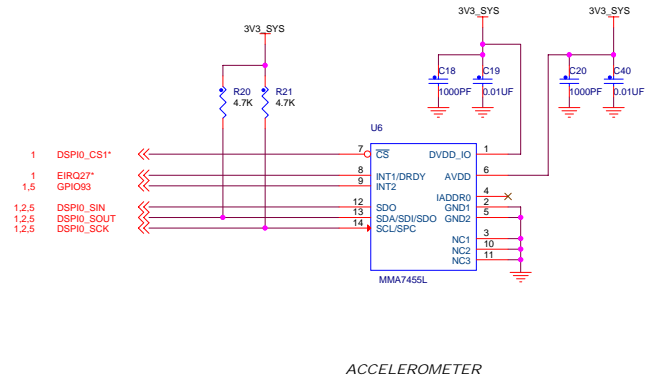
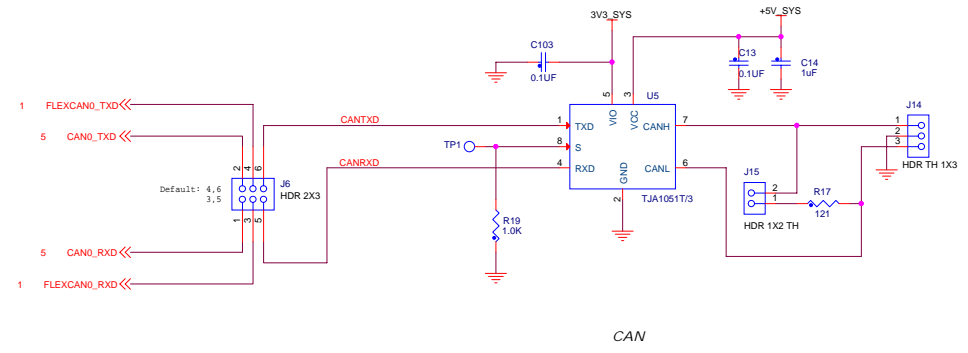

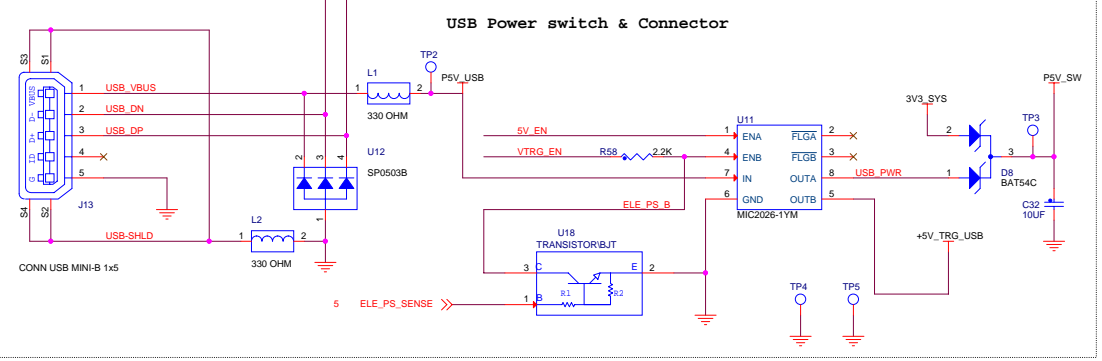
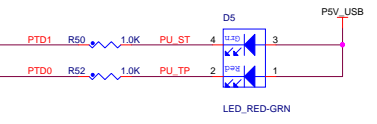
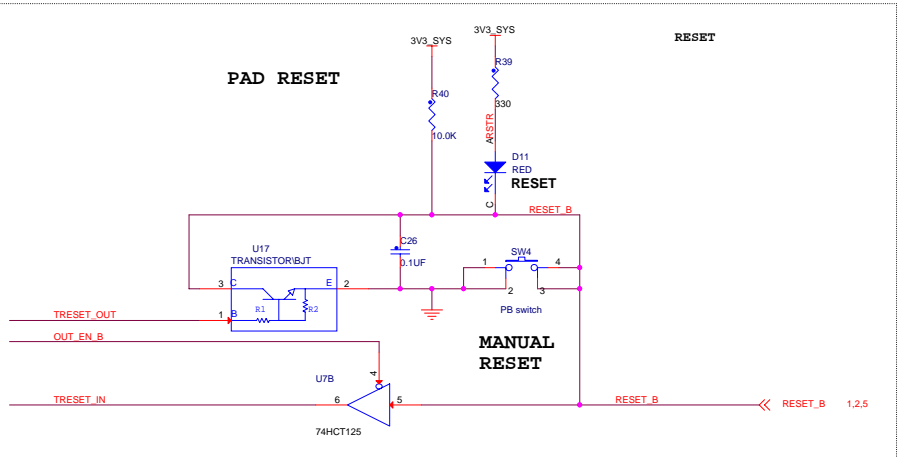
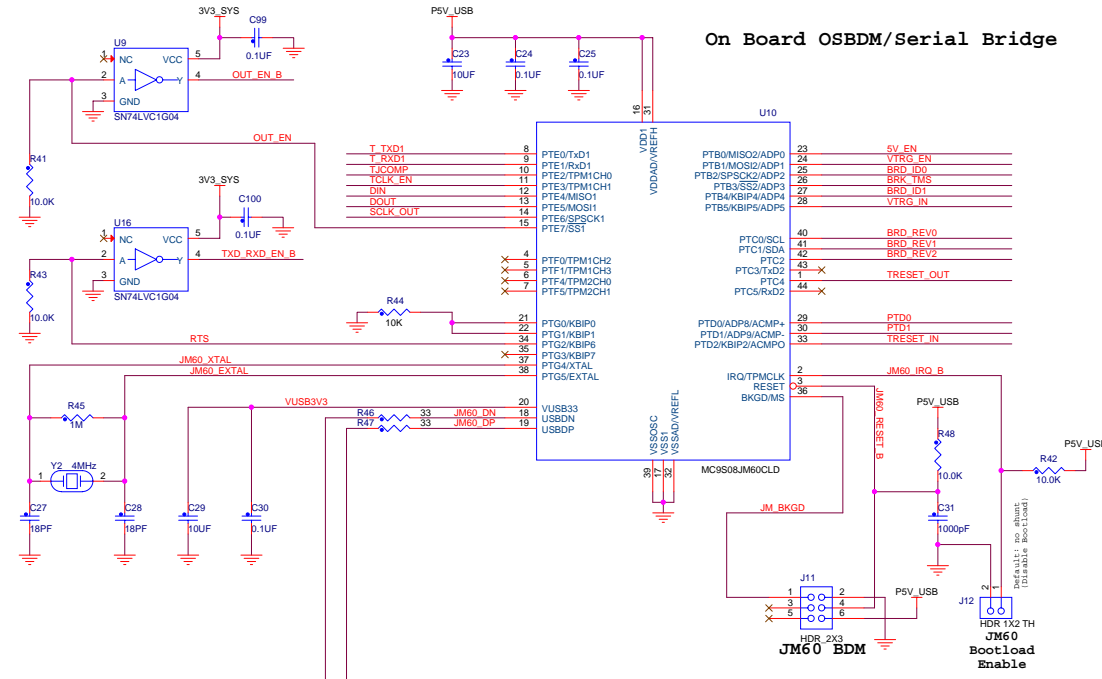
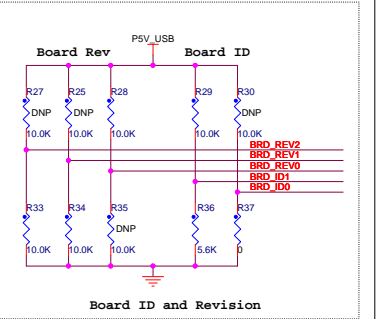
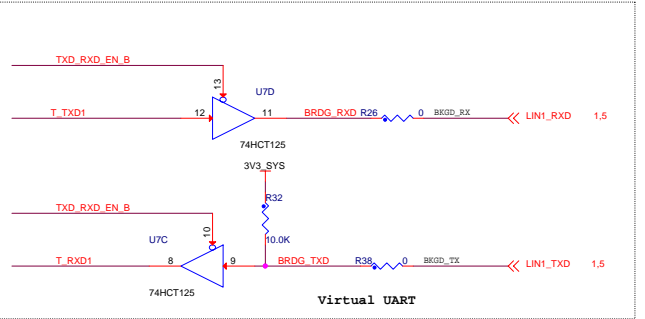
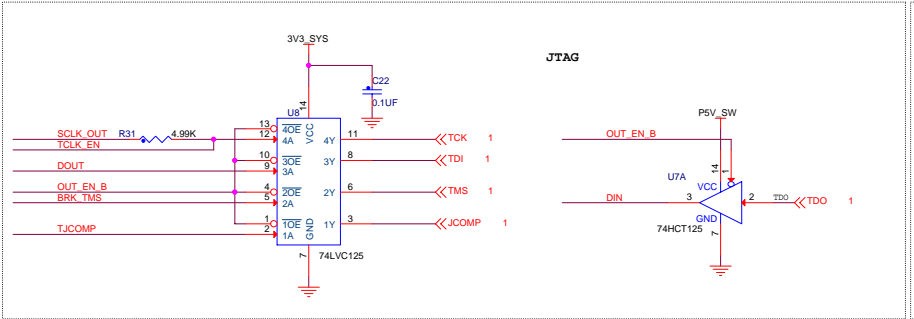

Approvals		Date	File	
Drawn	GLG	081611	TWR-PXS20 AXM-0559	
Checked	DSR	081611	Size	Document Number
Finish			C	DOC-0559-030
Date: Monday, April 02, 2012			Sheet	3 of 5

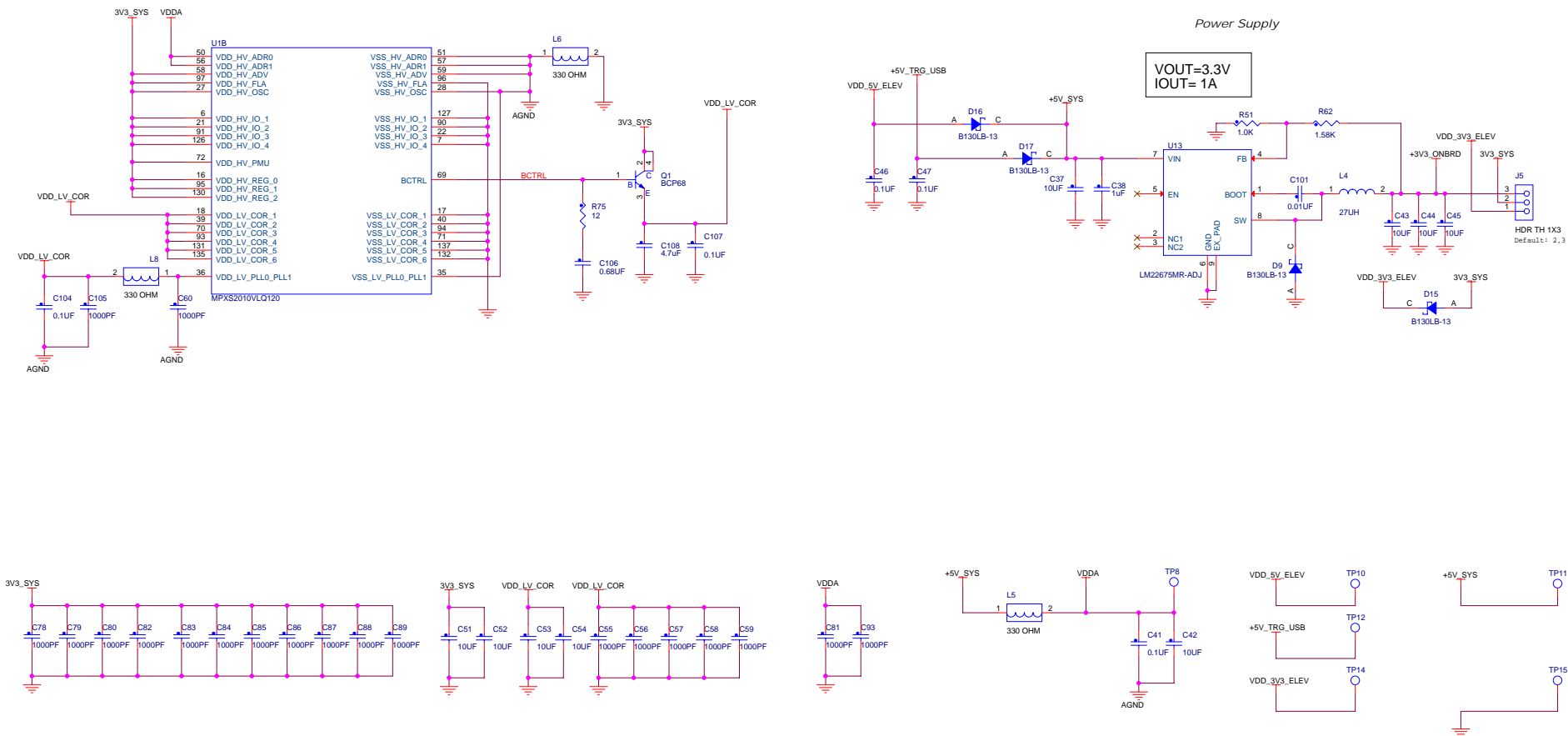

Approvals		Date	File	
Drawn	GLG	081611	TWR-PXS20 AXM-0559	
Checked	DSR	081611	Size	Document Number
Finish			C	DOC-0559-030
Date: Monday, April 02, 2012			Rev	B2
Sheet 4 of 5				

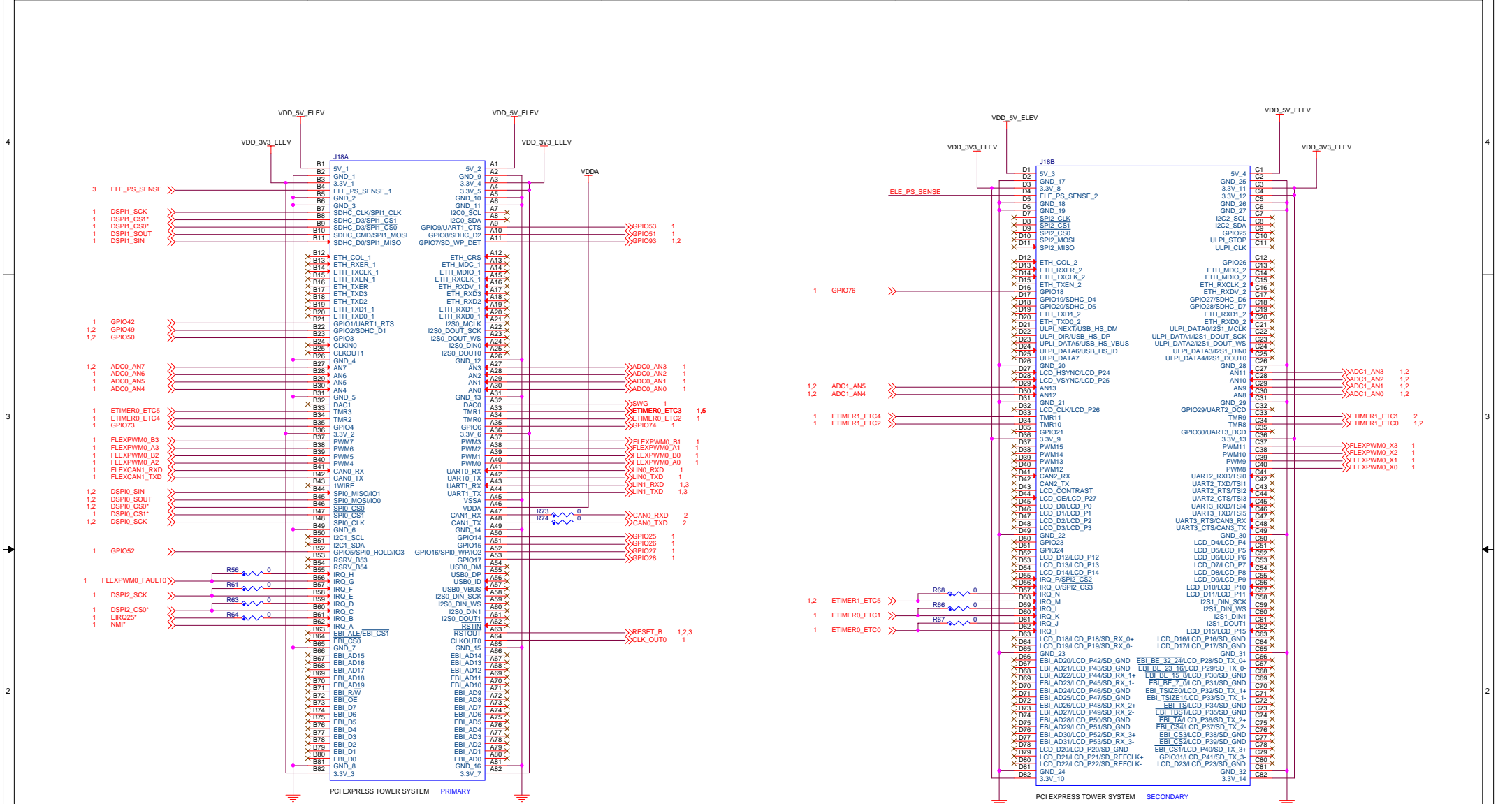

Approvals	Date
Drawn GLG	081611
Checked DSR	081611
Finish	
File TWR-PXS20 AXM-0559	
Document Number DOC-0559-030	
Date: Monday, April 02, 2012	
Sheet 5 of 5	