



<b>Contents</b>
IA2600

Revisions			
Rev	Description	Date	Approved
X2	RELEASE TO AGILE	10 NOV 2010	PASCAL BERNARD

		<b>Microcontroller Solutions Group</b>	
6501 William Cannon Drive West Austin, TX 78735-8598			
This document contains information proprietary to Freescale Semiconductor and shall not be used for engineering design, procurement or manufacture in whole or in part without the express written permission of Freescale Semiconductor.			
ICAP Classification:		FCP:	FIUQ: X PUBL:
Designer: Pascal Bernard	Drawing Title: <b>TWRMOD-MMA2600</b>		
Drawn by: Andrew MacDonald	Page Title: <b>TITLE PAGE</b>		
Approved: Pascal Bernard	Size C	Document Number SCH-26902 PDF: SPF-26902	Rev A
Date:	Monday, June 13, 2011	Sheet	1 of 3



ICAP Classification:		FCP:	FLIQ: X
Drawing Title:		PUB:	
<b>TWRMOD-MMA2600</b>			
Page Title:			
<b>NOTES</b>			
Size	Document Number	Rev	
C	SCH-26902 PDF: SPF-26902	A	
Date:	Monday, June 13, 2011	Sheet	2 of 3

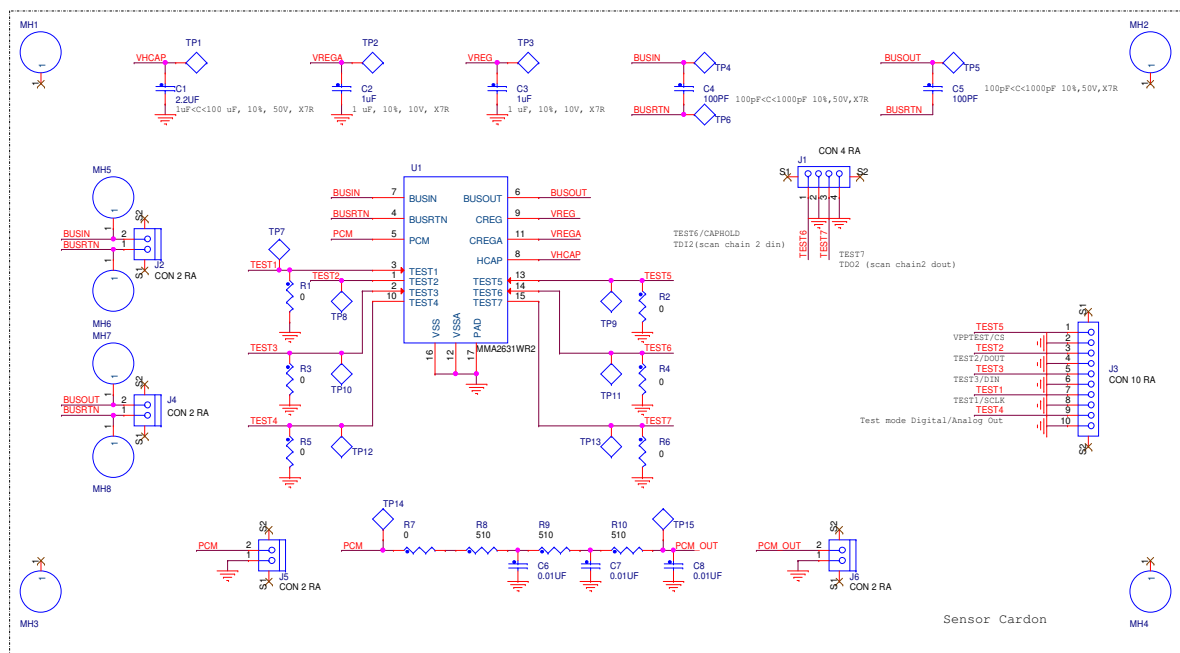

Sensor Cardon