

UM10363

UBA2024 application development tool

Rev. 02 — 4 February 2010

User manual

Document information

Info	Content
Keywords	UBA2024, application, development, tool, CFL, IC
Abstract	User manual for the UBA2024 application development tool for CFL lamps



Revision history

Rev	Date	Description
02	20100204	<ul style="list-style-type: none">Text and technical content updatedSection 8 “Legal information” updated.
01	20090618	First release

Contact information

For more information, please visit: <http://www.nxp.com>

For sales office addresses, please send an email to: salesaddresses@nxp.com

1. Introduction

The on-line UBA2024 application development tool is an aid in developing electronic circuits for CFL lamps using the UBA2024 IC family. The tool helps to calculate the values for the resonance capacitor and inductor. With the tool the application can be verified for power levels and phase shift over a wide range of the mains supplies.

The tool is based on the basic applications schematic as shown in [Figure 1](#). The tool currently supports four different versions of the UBA2024. The supported devices with the main parameters are listed in [Table 2](#). [Figure 2](#) shows a screen shot of the tool. Three different colors are used in the tool. All input fields are amber, advised (calculated) values are in blue, and actual values are in green. The same color scheme is used in the input and output fields of the graphs. A quick design procedure help function is available under the Help menu.

The following subjects are explained within this document:

- The input parameters in [Section 2](#)
- The output parameters in [Section 3](#)
- Error checking in [Section 4](#)
- Design overview and the Bill of Materials in [Section 5](#)
- File menu - saving, loading and printing of a design in [Section 6](#)
- Design procedure in [Section 7](#).

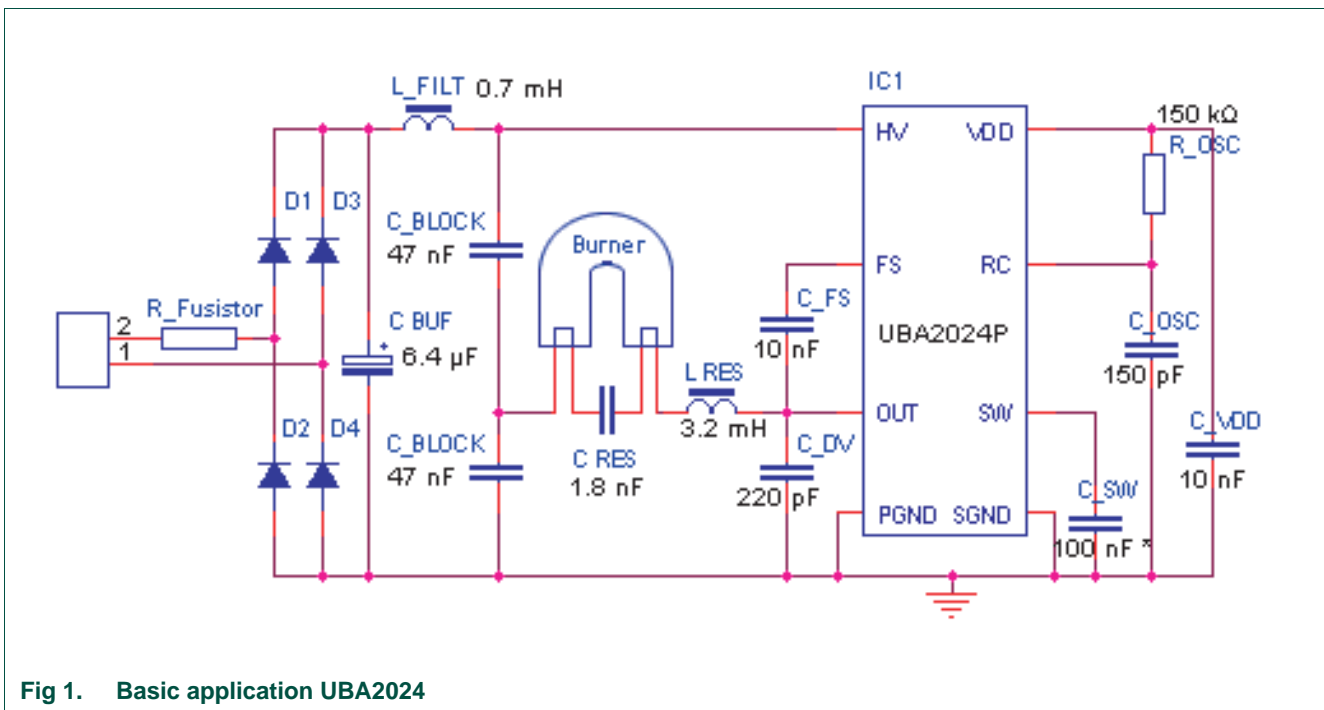

Fig 1. Basic application UBA2024

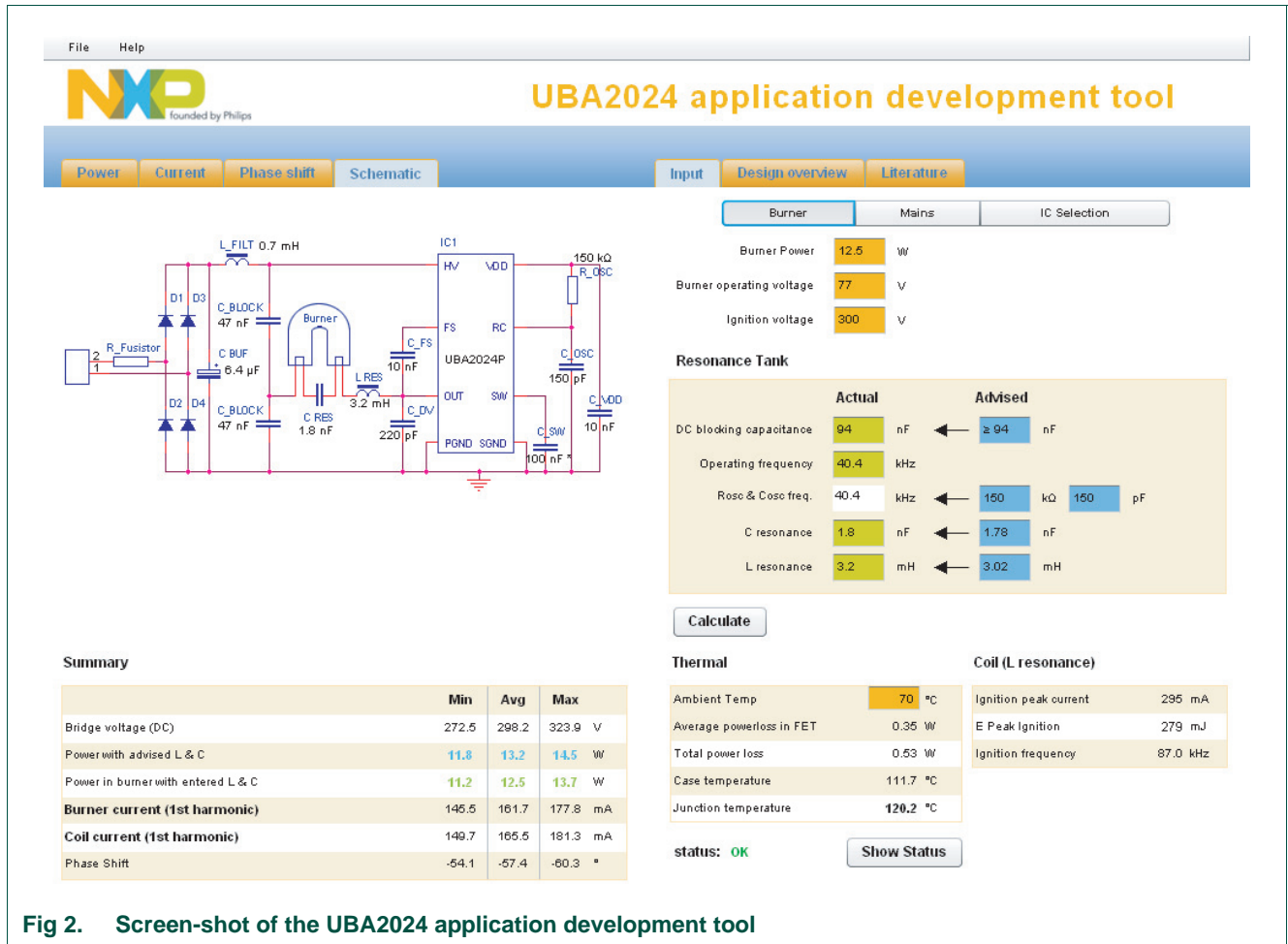

Fig 2. Screen-shot of the UBA2024 application development tool

1.1 Disclaimer

The purpose of this tool is to give guidance during the design of a CFL application in combination with the UBA2024. NXP Semiconductors expressly disclaims any representations or warranties, expressed or implied that the application is suitable for the specified use, without further testing or modification, and shall have no liability for the consequences of use of this tool. Actual values can differ from values calculated in this sheet due to tolerances in the components used in the application and due to limitations of the model used in the calculations.

2. Input parameters

To calculate the application values, the user must enter the burner data, the mains voltage, and the initial values of some of the application components. These input fields are explained in paragraphs [Section 2.1](#).to [Section 2.8](#) inclusive.

2.1 Calculate

Every time you enter new data, you must click on the Calculate button before the tool will update the calculated values and graphs.

2.2 Burner data

The tool calculates around a given CFL burner. It is important to enter the data of the burner and not of the final lamp, see [Figure 3](#). For example, a 15 W lamp can be built with a 12.5 W burner. Therefore:

- The 12.5 W is entered in the “**Burner power**” input field
- The burner RMS voltage (not peak) of the burner at nominal power, is entered in the “**Burner operating voltage**” field
- The ignition voltage worst case peak value is entered in the “**Ignition voltage**” field.

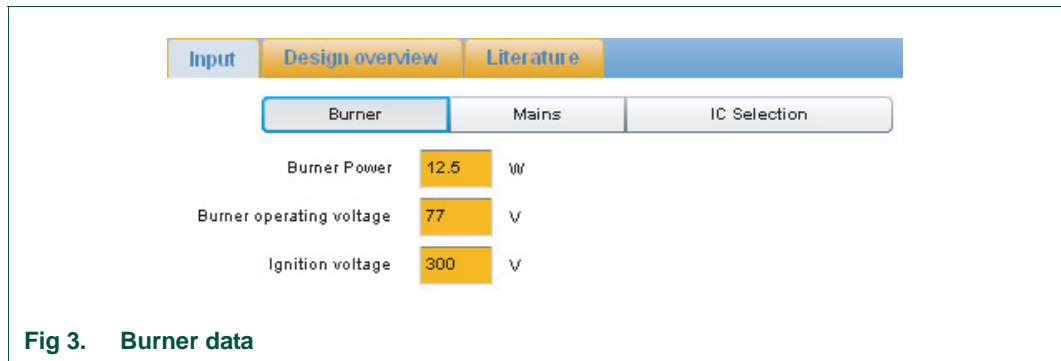

Fig 3. Burner data

2.3 Mains voltage

Enter the nominal mains RMS voltage and frequency together with the buffer capacitor value, see [Figure 4](#). As a guideline for the buffer capacitor, you can use the values as shown in [Table 1](#). This value can be changed at any time if needed.

You can verify how the lamp will behave under variation of the mains voltage at a later stage. At the beginning of the design process, the mains variation should be set to 0 %. If the ripple voltage will be too high, a warning will be shown, asking you to increase the buffer capacitor.

Table 1. Advised buffer capacitor for 230 V (AC)

Lamp power	Buffer capacitor
5 W	2.2 μ F
6 W to 8 W	3.3 μ F
9 W to 11 W	4.7 μ F
12 W to 15 W	6.8 μ F
15 W to 25 W	10 μ F

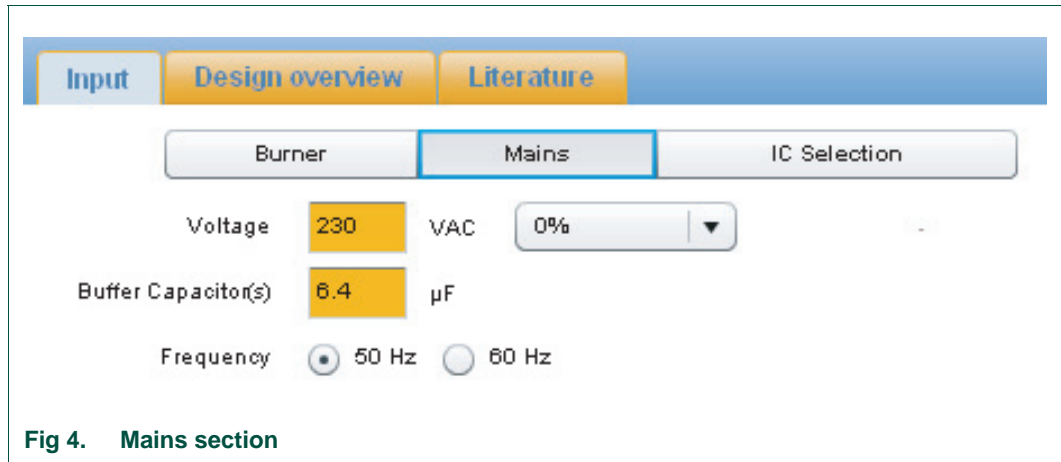

Fig 4. Mains section

2.3.1 Mains variation

The application can be verified over a range of mains voltages. To the right of the Mains, Voltage input field, a drop-down menu is available, values of -25 % to +25 % can be chosen, in 5 % steps, see [Figure 5](#). After changing the mains variation, the tool will automatically calculate the new situation.

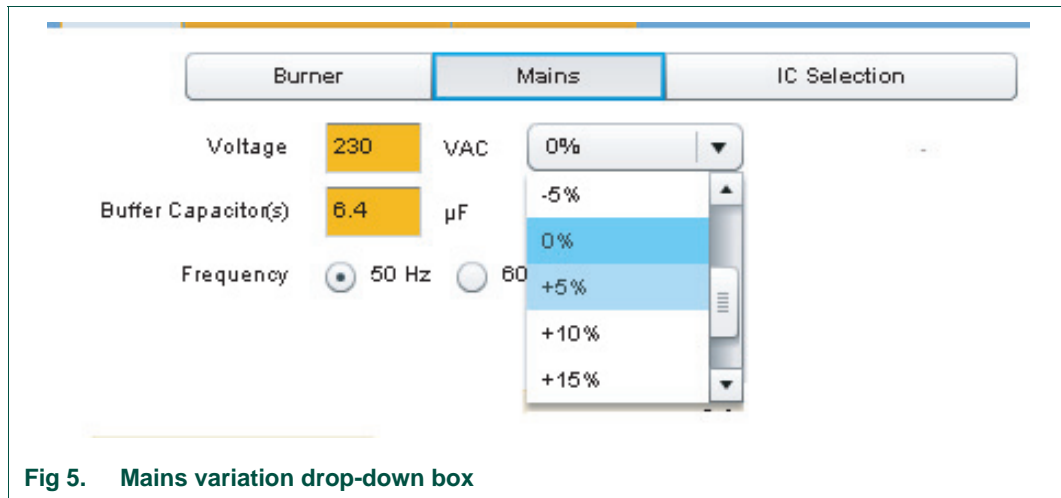

Fig 5. Mains variation drop-down box

Remark: The tool always calculates a LC combination that has the requested output power in the burner, which means that the advised LC value will change when a different value is chosen from the drop-down box. Therefore, when you check how the application behaves with variations in mains, the actual LC should not be changed.

2.3.2 Voltage doubler

When using 110 V mains, a voltage doubler is often used, but this configuration is not currently supported by the tool. Please see the UBA2024 application note for the different solutions used to enable the UBA2024 to operate with 100 V to 120 V mains.

Remark: Some low power burners, which have low operating voltages, can be used without a voltage doubler. This tool can help you verify if this is possible with your burner.

2.3.3 Ripple voltage

Using the mains voltage, the rectifier voltage drop, and the buffer capacitor, estimated losses in the circuit and the burner power, the minimum and maximum DC voltages on the half bridge are calculated. The minimum and maximum voltages are used in all further calculations and are shown in the output table and graphs.

2.4 IC selection

The top most input field is a drop-down menu for the IC to be used. In [Table 2](#) the supported devices are shown. Select the IC that fits your lamp. The selection can be changed at any time during the design process if required.

Table 2. Supported devices

IC	Package	Power range W	R _{DSon} Ω	I _{max} RMS mA	I _{max} peak mA
UBA2024P	DIL-8	Up to 15	9.0	220	900
UBA2024AP	DIL-8	Up to 25	6.0	270	1350
UBA2024T	SO14	Up to 15	9.0	220	900
UBA2024AT	SO14	Up to 20	6.4	260	1260

The maximum power depends on the burner used. Higher power lamps can be built with a burner that has a lower current at a given power (and thus a higher operating voltage). The tool does not check on the given power, it checks on the maximum RMS current through the integrated half bridge FETs and the junction temperature.

2.5 DC blocking capacitor

The combined value of the DC blocking capacitors is entered in the DC blocking capacitance field, see [Figure 6](#). For example when two 47 nF capacitors are used, a value of 94 nF should be entered. On the right of the input field, in the blue field, an Advised value is shown. Initially this value can be used.

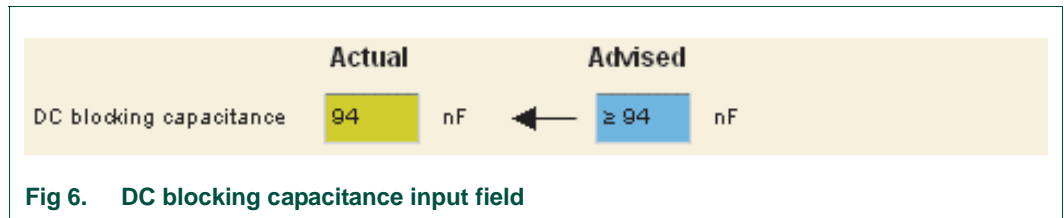

Fig 6. DC blocking capacitance input field

2.6 Operating frequency

The operating frequency can be any frequency up to 60 kHz. Often frequencies between 30 kHz and 40 kHz are not used to prevent interference with IR remote control devices. Frequencies lower than 25 kHz can cause audible noise and therefore should also not be used. Frequencies higher than 50 kHz can make the filtering for EMI more difficult. Considering these limitations, the recommended frequency ranges are: 25 kHz to 30 kHz or 40 kHz to 50 kHz.

The Oscillator frequency is set by two components: R_{osc} and C_{osc}. The tool calculates a value for these two components, see [Figure 7](#). Different values can be calculated using [Equation 1](#)

$$f_{OSC} = \frac{1}{L \cdot R_{OSC} \cdot C_{OSC}} \tag{1}$$

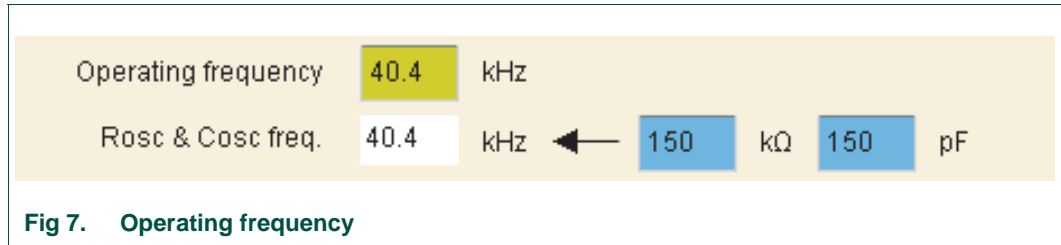

Remark: Please remember that the frequency will vary due to the tolerances of the components used.

2.7 Resonant circuit

The tool will calculate a value of the coil and the capacitor in the resonance circuit, so that the average burner power equals the entered nominal burner power. These values are shown in the fields with a blue background, see [Figure 8](#). You can use these values as a basis, or use your own values. In the graphs, the blue lines are based on these advised values. The green lines are based on the entered values of L and C.

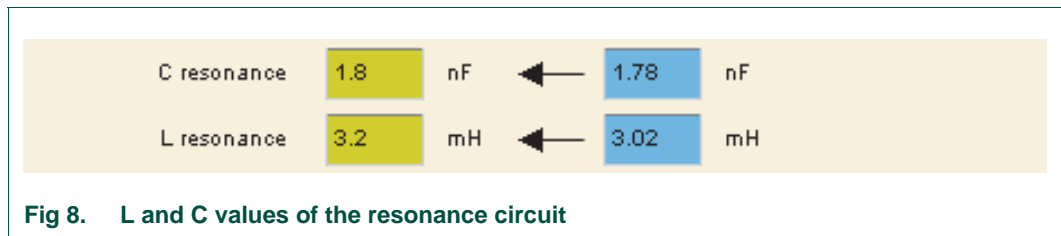

A higher inductance value of the coil will reduce the burner current and thus burner power. A lower inductance will increase the burner power.

The capacitor value will determine the amount of heating of the filaments. Larger capacitors will give higher filament currents, lower capacitance will give lower filament currents.

2.8 Ambient temperature

The ambient temperature is entered to check the junction temperature of the IC. The ambient temperature will depend on the physical design of the PCB and housing of the final lamp.

3. Output parameters

Using the data entered in the fields explained in [Section 2](#), the tool will calculate parameters that are critical for a suitable CFL application. Both for normal operation and during ignition. Normal operation is explained in [Section 3.1](#). and all the parameters related to ignition are explained in [Section 3.2](#).

3.1 Burn mode

The most important parameters during normal operation are the burner power, the half bridge current and the voltage/current phase shift in the half bridge. This data is summarized in a table and shown in 3 different graphs.

3.1.1 Summary table

[Figure 9](#) shows the summary table with examples of output data. It shows the values of the power, current and phase shift for the minimum, average and maximum bridge voltages.

All calculations are done with the first harmonic of the square wave of the half bridge. These will not be the exact value of the real currents in the application, but in general, the results are close enough to be usable.

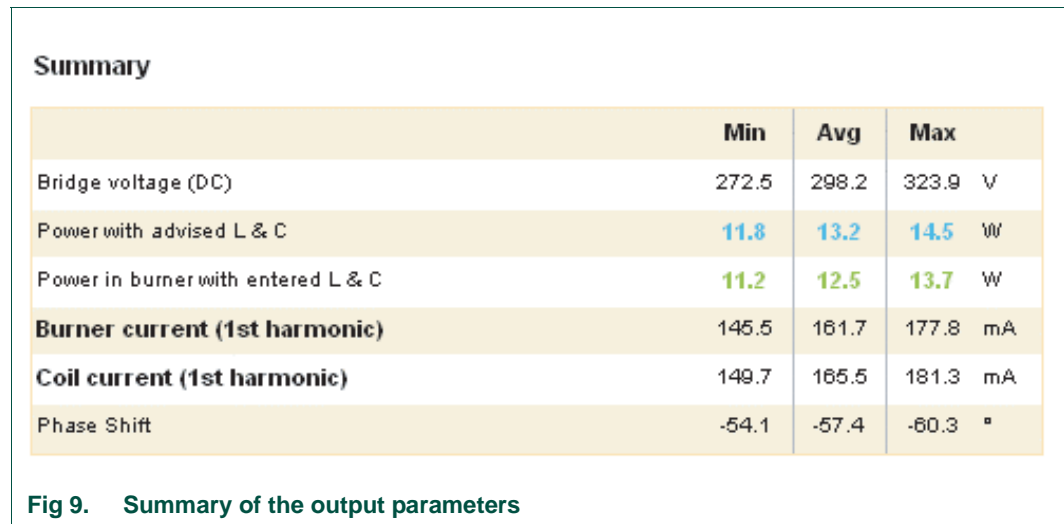

3.1.2 Burner power

The graph in [Figure 10](#) shows the burner power versus the bridge ripple voltage. Both the power with the advised LC values and with the actual LC values are shown. The green line shows the power based on the actual LC values that are entered by the user of the tool. The blue line shows the power based on the advised values of the LC.

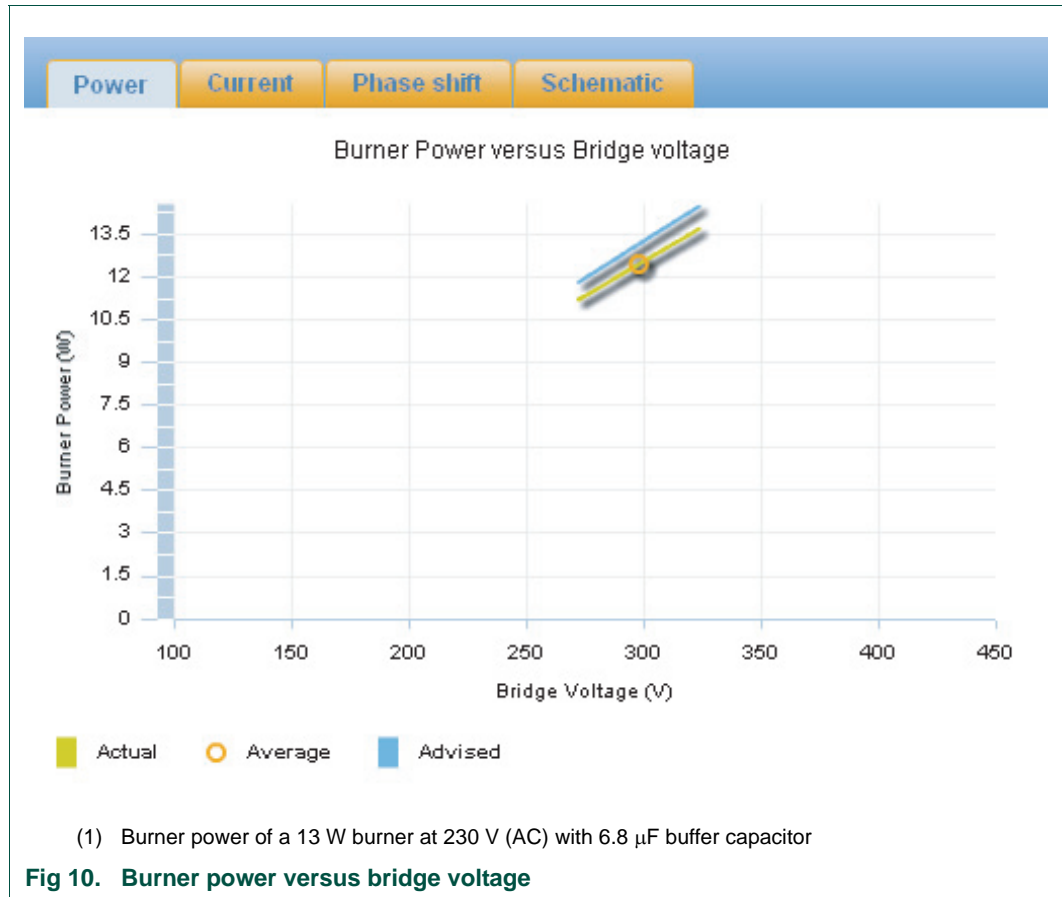

3.1.3 Half bridge current

The graph in [Figure 11](#) shows the RMS current in the half bridge. This current should be limited to the maximum current allowed for the IC. The red line in the graph shows the limit. The limit depends on the IC used. Only the current for the actual values of LC is shown. When the current exceeds this limit, the lifetime of the IC is reduced. The maximum half bridge current should be checked at the highest mains supply (+xx %). Where xx is the maximum variation that is allowed on the mains voltage.

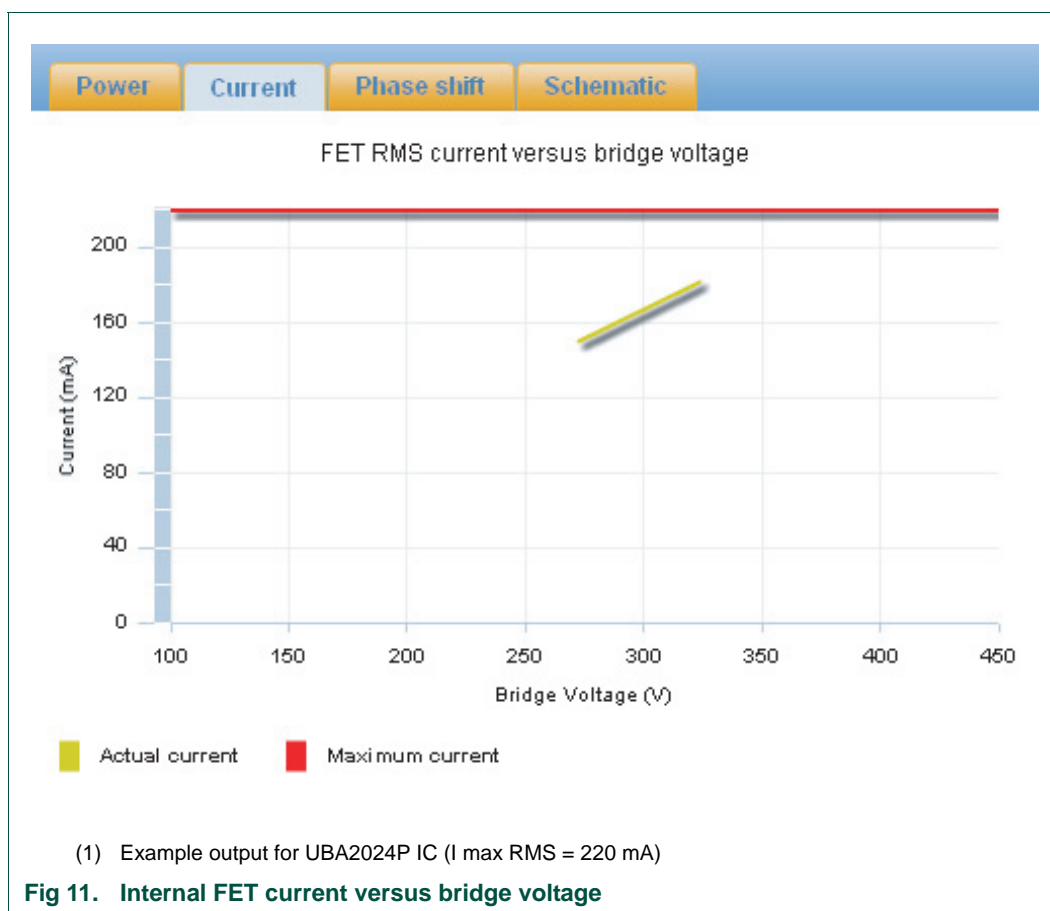

3.1.4 Phase shift

The phase shift between the current and voltage in the half bridge should never be positive. A positive phase shift results in capacitive mode and hard switching of the FETs, which can destroy the IC. The advised phase shift during nominal operation is between -40 degrees and -60 degrees. The phase shift should be checked at the lowest possible main voltage ($-xx\%$). Where xx is the maximum variation that is allowed on the mains voltage. The graph in [Figure 12](#) shows the phase shift versus half bridge voltage.

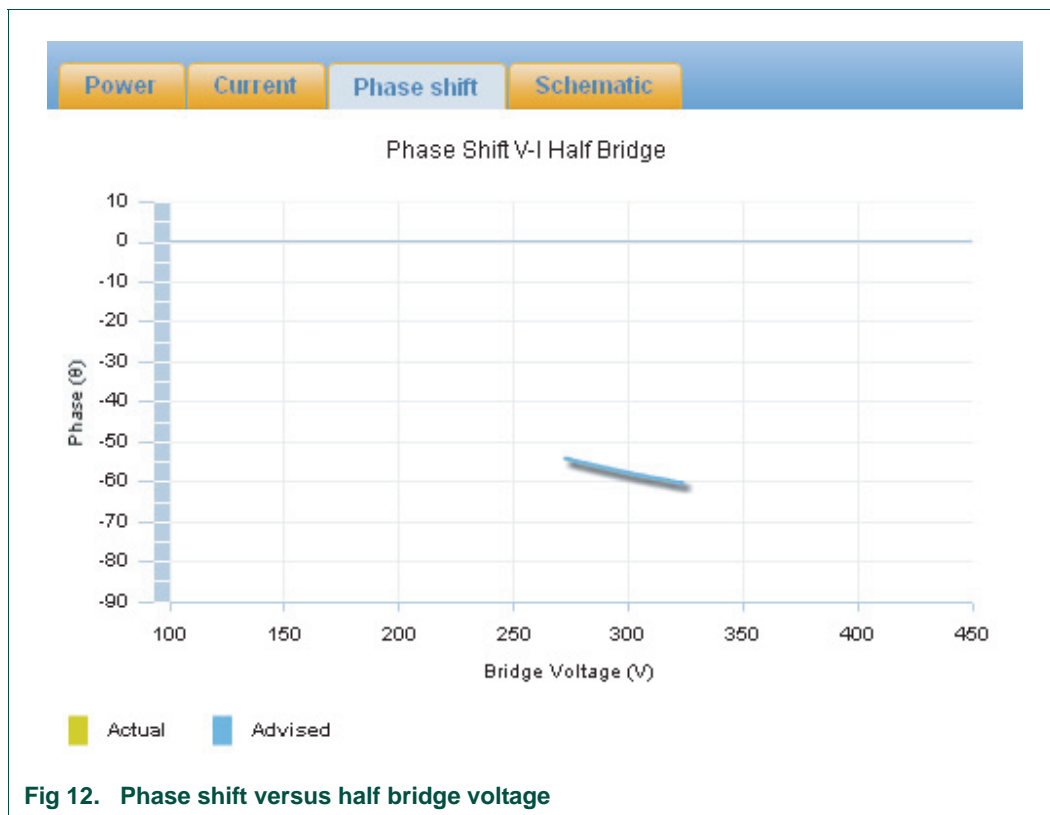

Fig 12. Phase shift versus half bridge voltage

3.2 Ignition

3.2.1 Ignition current

The most important parameter during ignition is the maximum current through the coil and thus the IC. To prevent damage of the IC it is necessary to prevent the coil to go into saturation during ignition. Please note that at higher temperatures the maximum saturation current can be reduced due to the properties of the materials used in most coils. Make sure that at it's maximum temperatures, the coil can store the amount of energy shown in the field "**E peak Ignition**".

The ignition peak current used for the coil specification should be the peak current at the highest possible mains voltage, that is mains +xx %. Where xx is the maximum variation that is allowed on the mains voltage.

The ignition peak current will also flow through the half bridge FETs and therefore should never exceed the saturation current of the integrated FETs. An error is given if the current is higher than the saturation current.

3.2.2 Ignition frequency

It is important that the magnetic material in the coil is suited for the ignition frequency.

Coil (L resonance)	
Ignition peak current	295 mA
E Peak Ignition	279 mJ
Ignition frequency	87.0 kHz

Fig 13. Ignition parameters

3.3 Junction temperature

The junction temperature of the IC should never exceed 150 °C. When the junction temperature exceeds this temperature the lifetime of the IC is drastically reduced and the IC will eventually breakdown.

The junction temperature should be checked at the highest mains input voltage.

Thermal	
Ambient Temp	70 °C
Average powerloss in FET	0.35 W
Total power loss	0.53 W
Case temperature	111.7 °C
Junction temperature	120.2 °C

Fig 14. Junction temperature

4. Error checking

The tool checks many different parameters, see [Figure 15](#). The four types of messages are Error, Warning, Attention and Hint.

- **Error:** errors should be prevented. Error conditions can damage the IC
- **Warning:** no damage to the IC, but unwanted behavior can happen
- **Attention:** risk of getting close to an error condition
- **Hint:** information that might help you to improve the design.

Clicking on the Show Status button will pop up a resizable window showing all the errors. If there are no errors present, the Status text box will be green.

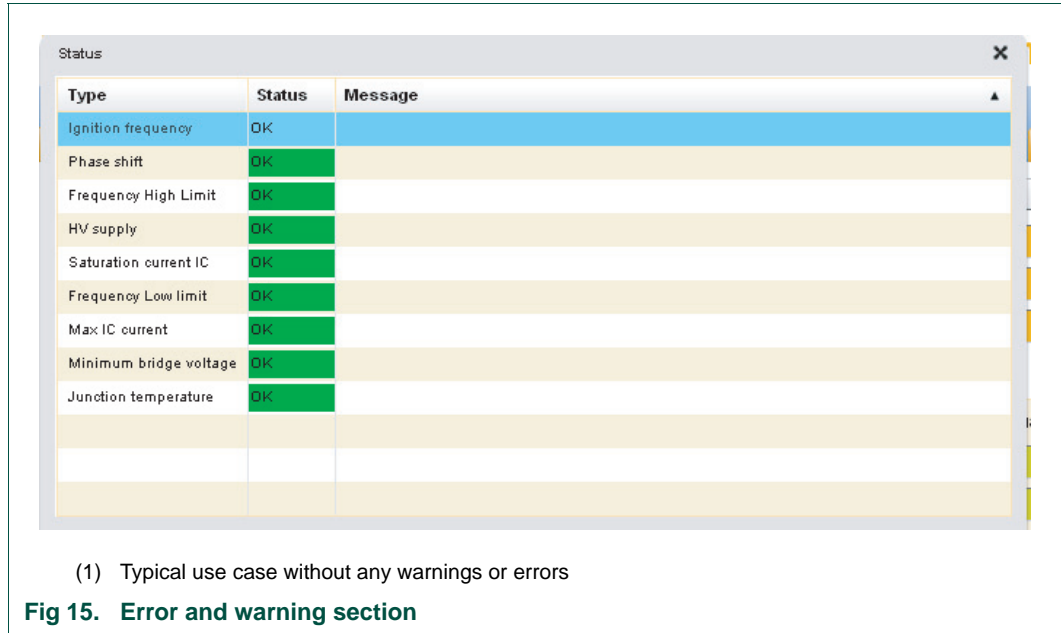

4.1 Error in calculation

When the tool can not calculate a certain parameter, an “**Error in calculation, please check input parameters**” will appear, E.G. this could be caused by a division by zero or negative complex numbers. This will happen when the phase shift is too low. Higher mains voltages or larger buffer capacitors could help to remove this error.

4.2 HV supply

An error message is shown if the maximum bridge voltage is higher than 500 V (DC). Higher voltages can destroy the IC.

Many electrolytic capacitors have a maximum rating of 400 V. When the maximum bridge voltage is above 400 V (DC) a warning is shown to remind to use components of a higher voltage rating.

4.3 Saturation current IC

During ignition a high current will run through the half bridge. To ensure the IC will not be destroyed an error is given if this current is too high.

4.4 Ignition frequency

To have enough time for the glow phase, the ignition frequency should be at least 1.6 times the operating frequency. (see [Equation 2](#)). If an “**Ignition frequency too low**” error is shown, either reduce the operating frequency or lower the resonance frequency of the LC circuit.

$$1.6 \times f_{operating} \leq f_{ignition} \leq 1.8 \times f_{operating} \tag{2}$$

The ignition frequency should preferably be less than 1.8 times the operating frequency. (see [Equation 2](#)) An error, however, is only shown if the ignition frequency is greater than 2.2 times the operating frequency.

The ignition frequency depends on the ignition voltage of the burner, the resonance frequencies (L, C and $C_{\text{block(DC)}}$) and the maximum bridge voltage.

4.5 Phase shift

To prevent hard switching of the FETs, the phase shift between the current and voltage in the half bridge should not be capacitive. [Table 3](#) shows the different messages.

Table 3. Phase shift error messages

Phase shift (degrees)	Type	Message
> 0	Error	Phase shift too low. Capacitive mode.
-20 to 0	Warning	Phase shift too small, risk of running into capacitive mode
-40 to -20	Attention	Phase shift not in optimal operating range, try phase shift < -40
< -40	OK	

The recommended phase shift is between -60 degrees and -40 degrees.

4.6 Maximum IC current

An error is shown if the RMS current through the FETs exceed the limit as given in [Table 2](#). When this limit is exceeded the lifetime of the IC is reduced and eventually the IC will break down.

4.7 Frequency low and high limit

A warning is given if the operating frequency is lower than 25 kHz. Lower frequencies can cause audible noise.

An error is given if the operating frequency is higher than 60 kHz. 60 kHz is the maximum operating frequency of the IC.

4.8 Minimum bridge voltage

For optimal efficiency the DC bridge voltage should be a factor approximately 2.2 higher than the burner RMS voltage (see [Equation 3](#))

$$V_{\text{bridge}} \geq \frac{\pi}{\sqrt{2}} V_{\text{burner}} \quad (3)$$

A message is shown if the bridge voltage is lower.

4.9 Maximum junction temperature

When the calculated junction temperature exceeds 150 °C, an error is shown.

5. Design overview

The design overview tab will give an overview of the design. The input data and the main characteristics are listed. Also given are the three graphs, the schematic, and finally a BOM (Bill of Materials) for the design. This overview can also be opened as a pdf file and using your pdf reader you can print the overview.

6. File menu

In the file menu, a design can be saved to the local hard disk. The design can be saved at any time during the design process and then be loaded again at a later time.

Also, a default design can be loaded, using Load default in the file menu, which will load default data with appropriate values.

When a design has been calculated, it can also be saved as a pdf file. The pdf file will contain the same data as the design overview.

7. Design procedure

With this tool it is now easy to design an application around a given burner. With the procedure described below, the basic component values are calculated. However, it is still necessary to build a prototype and to test the lamp thoroughly over all possible conditions, and possibly adjust some component values before completing the design. The tool can also be an aid to fine tuning the design.

1. Enter burner data: the nominal operating power, nominal operating RMS voltage and the worst case ignition peak voltage.
2. Enter the mains voltage and frequency and enter the buffer capacitor value. Set the mains variation to 0 %.
3. Enter the equivalent value of the DC blocking capacitors. When not sure of the value, use the advised value.
4. Enter the desired operating frequency. In most cases 40 kHz is used.
5. Click now on the Calculate button, or press the enter key to update the values.
6. Values for resonant L and C are calculated based on the entered operating frequency.
7. Enter a valid value for the resonant capacitor, closest to the calculated C from [List item 6](#).
8. Adjust the resonant L to get the desired average lamp power. As a start the calculated value from [List item 6](#) can be used.
9. Click now on the Calculate button, or press the enter key to update the values.
10. Verify that the lamp power is as expected for the minimum, maximum and average bridge voltages.
11. Verify that the current through the half bridge FETs is not exceeding the IC limit and that the junction temperature is not too high (> 150 °C).
12. Verify that phase shift does not cause capacitive mode. An optimal phase shift is between -40 degrees and -60 degrees.
13. If needed, some of the parameters can be adjusted. After adjusting go back to point 5 until a satisfactory solution is found.
14. Select the lowest mains voltage, e.g. -15 %, and verify if the phase shift does not cause capacitive mode.
15. Select the highest mains voltage, e.g. +15%, and verify that the half bridge FET current and the junction temperature does not exceed their limits.
16. Use the ignition peak current at the highest main voltage for the saturation limit of the coil of the resonant circuit.

8. Legal information

8.1 Definitions

Draft — The document is a draft version only. The content is still under internal review and subject to formal approval, which may result in modifications or additions. NXP Semiconductors does not give any representations or warranties as to the accuracy or completeness of information included herein and shall have no liability for the consequences of use of such information.

8.2 Disclaimers

Limited warranty and liability — Information in this document is believed to be accurate and reliable. However, NXP Semiconductors does not give any representations or warranties, expressed or implied, as to the accuracy or completeness of such information and shall have no liability for the consequences of use of such information.

In no event shall NXP Semiconductors be liable for any indirect, incidental, punitive, special or consequential damages (including - without limitation - lost profits, lost savings, business interruption, costs related to the removal or replacement of any products or rework charges) whether or not such damages are based on tort (including negligence), warranty, breach of contract or any other legal theory.

Notwithstanding any damages that customer might incur for any reason whatsoever, NXP Semiconductors' aggregate and cumulative liability towards customer for the products described herein shall be limited in accordance with the *Terms and conditions of commercial sale* of NXP Semiconductors.

Right to make changes — NXP Semiconductors reserves the right to make changes to information published in this document, including without limitation specifications and product descriptions, at any time and without notice. This document supersedes and replaces all information supplied prior to the publication hereof.

Suitability for use — NXP Semiconductors products are not designed, authorized or warranted to be suitable for use in medical, military, aircraft, space or life support equipment, nor in applications where failure or malfunction of an NXP Semiconductors product can reasonably be expected to result in personal injury, death or severe property or environmental damage. NXP Semiconductors accepts no liability for inclusion and/or use of NXP Semiconductors products in such equipment or applications and therefore such inclusion and/or use is at the customer's own risk.

Applications — Applications that are described herein for any of these products are for illustrative purposes only. NXP Semiconductors makes no representation or warranty that such applications will be suitable for the specified use without further testing or modification.

NXP Semiconductors does not accept any liability related to any default, damage, costs or problem which is based on a weakness or default in the customer application/use or the application/use of customer's third party customer(s) (hereinafter both referred to as "Application"). It is customer's sole responsibility to check whether the NXP Semiconductors product is suitable and fit for the Application planned. Customer has to do all necessary testing for the Application in order to avoid a default of the Application and the product. NXP Semiconductors does not accept any liability in this respect.

Export control — This document as well as the item(s) described herein may be subject to export control regulations. Export might require a prior authorization from national authorities.

8.3 Trademarks

Notice: All referenced brands, product names, service names and trademarks are the property of their respective owners.

9. Contents

1	Introduction	3
1.1	Disclaimer	4
2	Input parameters	4
2.1	Calculate	4
2.2	Burner data	5
2.3	Mains voltage	5
2.3.1	Mains variation	6
2.3.2	Voltage doubler	6
2.3.3	Ripple voltage	7
2.4	IC selection	7
2.5	DC blocking capacitor	7
2.6	Operating frequency	7
2.7	Resonant circuit	8
2.8	Ambient temperature	8
3	Output parameters	8
3.1	Burn mode	9
3.1.1	Summary table	9
3.1.2	Burner power	9
3.1.3	Half bridge current	10
3.1.4	Phase shift	11
3.2	Ignition	12
3.2.1	Ignition current	12
3.2.2	Ignition frequency	12
3.3	Junction temperature	13
4	Error checking	13
4.1	Error in calculation	14
4.2	HV supply	14
4.3	Saturation current IC	14
4.4	Ignition frequency	14
4.5	Phase shift	15
4.6	Maximum IC current	15
4.7	Frequency low and high limit	15
4.8	Minimum bridge voltage	15
4.9	Maximum junction temperature	15
5	Design overview	15
6	File menu	16
7	Design procedure	16
8	Legal information	17
8.1	Definitions	17
8.2	Disclaimers	17
8.3	Trademarks	17
9	Contents	18

Please be aware that important notices concerning this document and the product(s) described herein, have been included in section 'Legal information'.

© NXP B.V. 2010.

All rights reserved.

For more information, please visit: <http://www.nxp.com>

For sales office addresses, please send an email to: salesaddresses@nxp.com

Date of release: 4 February 2010

Document identifier: UM10363_2