



# **CodeWarrior™ Development Studio for ColdFire® Architectures v6.3 Targeting Manual**

Revised: 15 September 2006





Freescale™ and the Freescale logo are trademarks of Freescale Semiconductor, Inc. CodeWarrior is a trademark or registered trademark of Freescale Semiconductor, Inc. in the United States and/or other countries. All other product or service names are the property of their respective owners.

Copyright © 2006 by Freescale Semiconductor, Inc. All rights reserved.

Information in this document is provided solely to enable system and software implementers to use Freescale Semiconductor products. There are no express or implied copyright licenses granted hereunder to design or fabricate any integrated circuits or integrated circuits based on the information in this document.

Freescale Semiconductor reserves the right to make changes without further notice to any products herein. Freescale Semiconductor makes no warranty, representation or guarantee regarding the suitability of its products for any particular purpose, nor does Freescale Semiconductor assume any liability arising out of the application or use of any product or circuit, and specifically disclaims any and all liability, including without limitation consequential or incidental damages. “Typical” parameters that may be provided in Freescale Semiconductor data sheets and/or specifications can and do vary in different applications and actual performance may vary over time. All operating parameters, including “Typicals”, must be validated for each customer application by customer's technical experts. Freescale Semiconductor does not convey any license under its patent rights nor the rights of others. Freescale Semiconductor products are not designed, intended, or authorized for use as components in systems intended for surgical implant into the body, or other applications intended to support or sustain life, or for any other application in which the failure of the Freescale Semiconductor product could create a situation where personal injury or death may occur. Should Buyer purchase or use Freescale Semiconductor products for any such unintended or unauthorized application, Buyer shall indemnify and hold Freescale Semiconductor and its officers, employees, subsidiaries, affiliates, and distributors harmless against all claims, costs, damages, and expenses, and reasonable attorney fees arising out of, directly or indirectly, any claim of personal injury or death associated with such unintended or unauthorized use, even if such claim alleges that Freescale Semiconductor was negligent regarding the design or manufacture of the part.

## How to Contact Us

Corporate Headquarters	Freescale Semiconductor, Inc. 7700 West Parmer Lane Austin, TX 78729 U.S.A.
World Wide Web	<a href="http://www.freescale.com/codewarrior">http://www.freescale.com/codewarrior</a>
Technical Support	<a href="http://www.freescale.com/support">http://www.freescale.com/support</a>

# Table of Contents

---

<b>1</b>	<b>Introduction</b>	<b>7</b>
	Read the Developer Notes . . . . .	7
	Features . . . . .	7
	CodeWarrior Editions . . . . .	8
	About this Manual . . . . .	9
	Documentation Overview . . . . .	10
	Additional Information Resources . . . . .	10
<b>2</b>	<b>Getting Started</b>	<b>13</b>
	System Requirements . . . . .	13
	Host Requirements . . . . .	13
	Target Board Requirements . . . . .	14
	CodeWarrior IDE . . . . .	14
	CodeWarrior Development Process . . . . .	15
	Project Files . . . . .	17
	Editing Code . . . . .	18
	Building: Compiling and Linking . . . . .	18
	Debugging . . . . .	19
	Disassembling . . . . .	19
<b>3</b>	<b>Application Tutorial</b>	<b>21</b>
	Create a Project . . . . .	21
	Build the Project . . . . .	25
	Debug the Application . . . . .	27
<b>4</b>	<b>Target Settings</b>	<b>33</b>
	Target Settings Overview . . . . .	33
	ColdFire Settings Panels . . . . .	34
	Target Settings . . . . .	35
	BatchRunner PreLinker . . . . .	37
	BatchRunner PostLinker . . . . .	37
	ColdFire Target . . . . .	38



## Table of Contents

---

ColdFire Assembler . . . . .	38
ELF Disassembler . . . . .	41
ColdFire Processor . . . . .	45
ColdFire Linker . . . . .	48
Debugger PIC Settings . . . . .	53
<b>5 Debugging</b>	<b>55</b>
Target Settings for Debugging . . . . .	55
CF Debugger Settings Panel . . . . .	56
Remote Debugging Panel . . . . .	59
CF Exceptions Panel . . . . .	63
Debugger Settings Panel . . . . .	66
CF Interrupt Panel . . . . .	68
Remote Connections for Debugging . . . . .	69
Abatron Remote Connections . . . . .	71
Freescale Remote Connections . . . . .	73
P&E Microsystems Remote Connections . . . . .	76
ISS Remote Connection . . . . .	80
BDM Debugging . . . . .	83
Connecting a P&E Parallel Connector . . . . .	83
Connecting an Abatron BDI Device . . . . .	83
Debugging ELF Files without Projects . . . . .	85
Updating IDE Preferences . . . . .	85
Customizing the Default XML Project File . . . . .	86
Debugging an ELF File . . . . .	87
Additional ELF-Debugging Considerations . . . . .	87
Special Debugger Features . . . . .	88
ColdFire Menu . . . . .	88
Working with Target Hardware . . . . .	89
Using the Simple Profiler . . . . .	90
<b>6 Instruction Set Simulator</b>	<b>91</b>
Features . . . . .	91
ColdFire V2 . . . . .	91
ColdFire V4e . . . . .	92

---

---

Using the Simulator . . . . .	93
Console Window . . . . .	93
Viewing ISS Registers . . . . .	94
ISS Configuration Commands . . . . .	94
bus_dump . . . . .	95
cache_size . . . . .	96
ipsbar . . . . .	96
kram_size . . . . .	97
krom_size . . . . .	97
krom_valid. . . . .	98
mbar. . . . .	98
mbus_multiplier . . . . .	99
memory . . . . .	99
sdram. . . . .	100
Sample Configuration File . . . . .	100
ISS Limitations . . . . .	101
<b>7 Using Hardware Tools . . . . .</b>	<b>103</b>
Flash Programmer . . . . .	103
Hardware Diagnostics . . . . .	108
<b>8 Using Debug Initialization Files . . . . .</b>	<b>113</b>
Common File Uses . . . . .	113
Command Syntax . . . . .	115
Command Reference. . . . .	116
Delay . . . . .	116
ResetHalt . . . . .	117
ResetRun . . . . .	117
Stop . . . . .	117
writeaddressreg . . . . .	117
writecontrolreg . . . . .	118
writedatareg . . . . .	118
writemem.b . . . . .	119
writemem.l . . . . .	119
writemem.w . . . . .	120



## Table of Contents

---

<b>9</b>	<b>Memory Configuration Files</b>	<b>121</b>
	Command Syntax . . . . .	121
	Command Explanations . . . . .	122
	range . . . . .	122
	reserved . . . . .	123
	reservedchar . . . . .	123
	<b>Index</b>	<b>125</b>

# Introduction

---

This manual explains how to use CodeWarrior™ development tools to develop applications for the Freescale™ ColdFire® family of integrated microprocessors.

This chapter consists of these sections:

- [Read the Developer Notes](#)
- [Features](#)
- [CodeWarrior Editions](#)
- [About this Manual](#)
- [Documentation Overview](#)
- [Additional Information Resources](#)

## Read the Developer Notes

Before using the CodeWarrior IDE, read the developer notes. These notes contain important information about last-minute changes, bug fixes, incompatible elements, or other topics that may not be included in this manual.

---

**NOTE** The release notes for specific components of the CodeWarrior IDE are located at location: {CodeWarrior\_Dir}\Release\_Notes, where {CodeWarrior\_Dir} is the CodeWarrior installation directory.

---

If you are new to the CodeWarrior IDE, read this chapter and the [Getting Started](#) chapter. This chapter provides references to resources of interest to new users; the Getting Started chapter helps you become familiar with the software features.

## Features

The CodeWarrior Development Studio for ColdFire Architectures includes these features:

- Latest version of the CodeWarrior IDE, which the *IDE User's Guide* explains.
- Support for the latest ColdFire processors: MCF5222x and MCF5223x.
- Support for previous processors of the ColdFire family, such as MCF547x/548x, MCF5206, MCF5208, MCF5213 (and its variants MCF5211 and MCF5212),

## Introduction

### CodeWarrior Editions

MCF523x, MCF5282, MCF5271, MCF5272, MCF5275, MCF5282, MCF5307, MCF5329, and MCF5249. For more information, see [ColdFire Processor](#)

- Flash-programmer and hardware-diagnostics support. For more information, see [Using Hardware Tools](#).
- Remote connection debugging support for a range of protocols:
  - Abatron protocols, see [Abatron Remote Connections](#).
  - Freescale’s USB TAP, see [Freescale Remote Connections](#).
  - P&E Micro protocols, see [P&E Microsystems Remote Connections](#).
- Instruction Set Simulator (ISS) for V2 and V4e processor cores. For more information, see [Remote Connections for Debugging](#) and [Instruction Set Simulator](#)
- Simple profiler support. For more information, see [Using the Simple Profiler](#). (This profiler support is not available for MCF521x, MCF5222x, and MCF5223x processors.)

## CodeWarrior Editions

There are three editions of CodeWarrior™ Development Studio for ColdFire® Architectures, version 6.3. [Table 1.1](#) shows their feature differences.

**Table 1.1 CodeWarrior ColdFire 6.3 Edition Features**

Feature	Special Edition	Standard Edition	Professional Edition
IDE	Yes	Yes	Yes
Compiles source code	ASM and C	ASM and C	ASM, C, and C++
Code size restrictions	128KB	None	None
Compiler optimization levels	Unlimited	Unlimited	Unlimited
3rd-party plug-ins	No RTOS	No RTOS	Unlimited RTOS plug-ins
CodeWarrior Debugger	Yes	Yes	Yes



**Table 1.1 CodeWarrior ColdFire 6.3 Edition Features (*continued*)**

Feature	Special Edition	Standard Edition	Professional Edition
Debugger hardware connections	P&E Parallel and USB, Cyclone Max, and USB TAP	P&E Parallel and USB, Cyclone Max, and USB TAP	P&E Parallel, USB, and Lightning; Abatron serial and TCP/IP, Cyclone Max, and USB TAP
V2, V4e simulator	No	Yes	Yes
Flash programmers	CodeWarrior Flash Programmer (129 megabytes) and ColdFire Flasher standalone plug-in	CodeWarrior Flash Programmer and ColdFire Flasher standalone plug-in	CodeWarrior Flash Programmer and ColdFire Flasher standalone plug-in
Real time operating system (RTOS)	Not available	Not available	Plug-ins available
Availability	Free with evaluation board	Available through all channels	Available through all channels. 30-day evaluation copy also available.

## About this Manual

[Table 1.2](#) lists the contents of this manual.

**Table 1.2 Chapter, Appendix Contents**

Chapter/Appendix	Explains
<a href="#">Introduction</a>	New features; contents of this manual; technical support; further documentation
<a href="#">Getting Started</a>	System requirements; overview of CodeWarrior development tools
<a href="#">Application Tutorial</a>	Tutorial for writing and debugging programs
<a href="#">Target Settings</a>	Controlling the compiler and linker

## Introduction

### Documentation Overview

**Table 1.2 Chapter, Appendix Contents (*continued*)**

Chapter/Appendix	Explains
<a href="#">Debugging</a>	Debugger settings panels; remote debugging connections
<a href="#">Instruction Set Simulator</a>	Instruction Set Simulator, including configuration for your requirements.
<a href="#">Using Hardware Tools</a>	Flash programmer and hardware diagnostics tools
<a href="#">Using Debug Initialization Files</a>	Debug initialization files
<a href="#">Memory Configuration Files</a>	Defining access for areas of memory

## Documentation Overview

Documentation for your CodeWarrior tools comes in three formats:

- **PDF manuals** — in subdirectory `\Help\PDF` of your installation directory.

---

**NOTE** For complete information about a particular topic, you may need to look in this Targeting manual and in the corresponding generic CodeWarrior manual. To view any PDF document, you need Adobe® Acrobat® Reader software, which you can download from: <http://www.adobe.com/acrobat>

---

- **CHM help files** — information in Microsoft® HTML Help CHM format, in folder `\Help` of the CodeWarrior installation directory. To view this information, start the CodeWarrior IDE, then select **Help > Online Manuals** from the main menu bar.
- **CodeWarrior online help** — information about using the IDE and understanding error messages. To access this information, start the CodeWarrior IDE, then select **Help > CodeWarrior Help** from the main menu bar.

## Additional Information Resources

- CodeWarrior IDE and related documentation can be found in the `\Help\PDF` subdirectory of your CodeWarrior installation directory:
- For general information about the CodeWarrior IDE and debugger, see the *IDE 5.7 User's Guide*.
- For information specific to building (compiling and linking), see the *ColdFire Build Tools Reference*.

- For information about the Main Standard Libraries for C/C++, see the *MSL C Reference* and the *MSL C++ Reference*.
- For PDF-format documentation about Freescale processors and cores, go to the `\Freescale_Documentation` subdirectory of your CodeWarrior installation directory.
- For Freescale documentation and resources, visit the Freescale, Inc. web site: <http://www.freescale.com>
- For additional electronic-design and embedded-system resources, visit the EG3 Communications, Inc. web site: <http://www.eg3.com>
- For monthly and weekly forum information about programming embedded systems (including source-code examples), visit the *Embedded Systems Programming* magazine web site: <http://www.embedded.com>



## **Introduction**

*Additional Information Resources*

---

# Getting Started

---

This chapter helps you install the CodeWarrior™ Development Studio for ColdFire Architectures. It also gives an overview of the CodeWarrior environment and tools.

This chapter consists of these sections:

- [System Requirements](#)
- [CodeWarrior IDE](#)
- [CodeWarrior Development Process](#)

## System Requirements

Your host computer system and your target board must meet minimum requirements.

### Host Requirements

Your computer (PC) needs:

- 800 MHz Pentium®-compatible microprocessor
- Windows® 2000 or XP operating system
- 512 megabytes of RAM
- CD-ROM drive
- 350 megabytes free memory space, plus space for projects and source code
- Serial port (or Ethernet connector), to connect your PC to the embedded target — for debugging with an Abatron BDI device or P&E Cyclone Max through Serial
- Parallel port (or P&E Lightning board) — to use a P&E parallel cable to connect to BDM/JTAG targets
- USB port — To use a P&E USB BDM debug cable (Cyclone Max or P&E USB Multilink) or Freescale USB TAP
- Ethernet connector -- to connect your PC to the embedded target for debugging with an Abatron BDI device or P&E Cyclone Max through TCP/IP

## Target Board Requirements

Your functional embedded system needs:

- ColdFire evaluation board, with a supported processor.
- Serial or null-modem cables to connect the host computer and target board, in case you would like to send printf output to a terminal; your target board determines the specific cables you need.
- BDM connector to be able to connect a supported BDM cable.
- Appropriate power supply for the target board.

## CodeWarrior IDE

The CodeWarrior IDE consists of a project manager, a graphical user interface, compilers, linkers, a debugger, a source-code browser, and editing tools. You can edit, navigate, examine, compile, link, and debug code, within the one CodeWarrior environment. The CodeWarrior IDE lets you configure options for code generation, debugging, and navigation of your project.

Unlike command-line development tools, the CodeWarrior IDE organizes all files related to your project. You can see your project at a glance, so organization of your source code files is easy. Navigation among those files is easy, too.

When you use the CodeWarrior IDE, there is no need for complicated build scripts or makefiles. To add or delete source code files from a project, you use your mouse and keyboard, instead of tediously editing a build script.

For any project, you can create and manage several configurations for use on different computer platforms. The platform on which you run the CodeWarrior IDE is called the *host*. From the host, you can use the CodeWarrior IDE to develop code to target various platforms.

Note the two meanings of the term *target*:

- **Platform Target** — The operating system, processor, or microcontroller in which/ on which your code will execute.
- **Build Target** — The group of settings and files that determine what your code is, as well as controlling the process of compiling and linking.

The CodeWarrior IDE lets you specify multiple build targets. For example, a project can contain one build target for debugging and another build target optimized for a particular operating system (platform target). These build targets can share project files, even though each build target uses its own settings. After you debug the program, the only actions necessary to generate a final version are selecting the project's optimized build target and using a single make command.

The CodeWarrior IDE's extensible architecture uses plug-in compilers and linkers to target various operating systems and microprocessors. For example, the IDE internally calls a C translator, compiler, and linker.

Most features of the CodeWarrior IDE apply to several hosts, languages, and build targets. However, each build target has its own unique features. This manual explains the features unique to the CodeWarrior IDE for Freescale ColdFire processors.

For comprehensive information about the CodeWarrior IDE, see the *Code Warrior IDE User's Guide*.

## CodeWarrior Development Process

The CodeWarrior IDE helps you manage your development work more effectively than you can with a traditional command-line environment. [Figure 2.1](#) depicts application development using the IDE.

## Getting Started

### CodeWarrior Development Process

Figure 2.1 CodeWarrior IDE Application Development

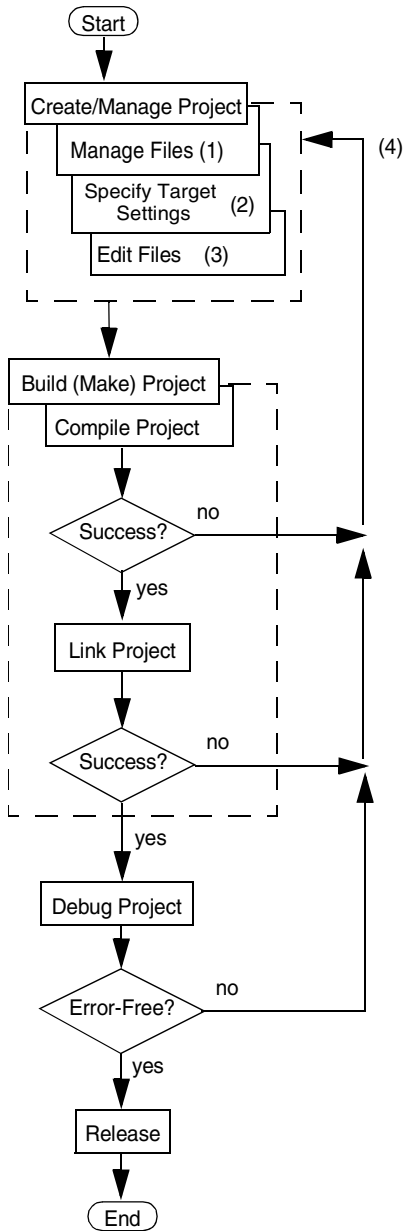

Notes:

(1) Use any combination: stationery (template) files, library files, or your own source files.

(2) Compiler, linker, debugger settings; target specification; optimizations.

(3) Edit source and resource files.

(4) Possible corrections: adding a file, changing settings, or editing a file.



## Project Files

A CodeWarrior project consists of source-code, library, and other files. The project window ([Figure 2.2](#)) lists all files of a project, letting you:

- Add files
- Remove files
- Specify the link order
- Assign files to build targets
- Have the IDE generate debug information for files

**Figure 2.2 Project Window**

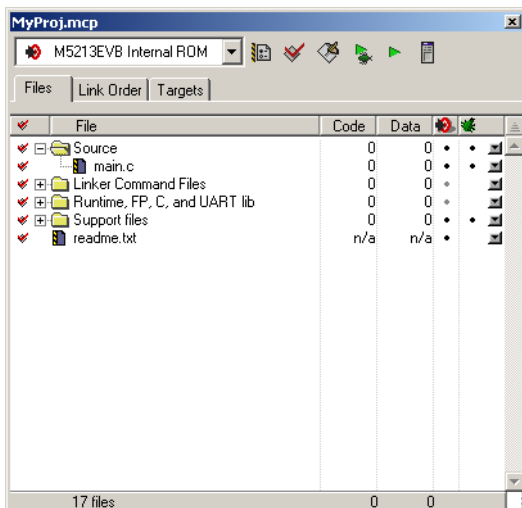

**NOTE** [Figure 2.2](#) shows a floating project window. Alternatively, you can dock the project window in the IDE main window or make the project window a child of the main window. You can have multiple project windows open at the same time; if the windows are docked, their tabs let you control which one is at the front of the main window.

The CodeWarrior IDE automatically handles dependencies among project files, storing compiler and linker settings for each build target. The IDE tracks which files have changed since your last build, recompiling only those files during your next project build.

A CodeWarrior project is analogous to a collection of makefiles, as the same project can contain multiple builds. Examples are a debug version and release version of code, both

## Getting Started

### CodeWarrior Development Process

part of the same project. As earlier text explained, *build targets* are such different builds within a single project.

## Editing Code

The CodeWarrior text editor handles text files in MS-DOS, UNIX, and MacOS formats.

To edit a source code file (or any other editable project file), double-click its filename in the project window. The IDE opens the file in the editor window ([Figure 2.3](#)). This window lets you switch between related files, locate particular functions, mark locations within a file, or go to a specific line of code.

**Figure 2.3** Editor Window

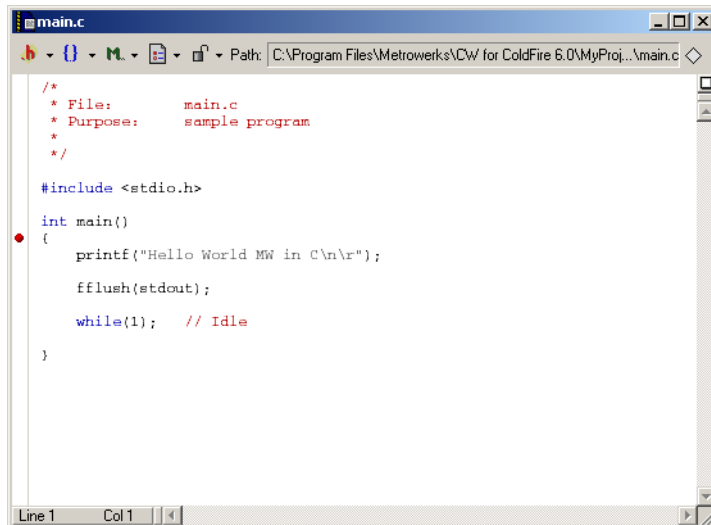

**NOTE** [Figure 2.3](#) shows a floating editor window. Alternatively, you can dock the project window in the IDE main window or make the project window a child of the main window.

## Building: Compiling and Linking

For the CodeWarrior IDE, *building* includes both compiling and linking. To start building, you select **Project > Make**, from the IDE main menu bar. The IDE compiler:

- Generates an object-code file from each source-code file of the build target, incorporating appropriate optimizations.

- Updates other files of the build target, as appropriate.
- In case of errors, issues appropriate messages and halts.

When compilation is done, building moves on to linking. The IDE linker:

- Links the object files into one executable file, in the link order you specify.
- In case of errors, issues appropriate error messages and halts.

When linking is done, you are ready to test and debug your application.

---

**NOTE** It is possible to compile a single source file. To do so, select the filename in the project window, then select **Project > Compile** from the main menu bar. Another useful option is compiling only the modified files of the build target: select **Project > Bring Up To Date** from the main menu bar.

---

## Debugging

To debug your application, select **Project > Debug** from the main menu bar. The debugger window opens, displaying your program code.

Run the application from within the debugger to observe results. The debugger lets you set breakpoints, to check register, parameter, and other values at specific points of code execution.

---

**NOTE** To debug code stored in Flash memory, you first must program the Flash. (The [Flash Programmer](#) subsection explains how to program a flash device.)

---

When your code executes correctly, you are ready to add features, to release the application to testers, or to release the application to customers.

---

**NOTE** Another debugging feature of the CodeWarrior IDE is viewing preprocessor output. This helps you track down bugs caused by macro expansions or another subtlety of the preprocessor. To use this feature, specify the output filename in the project window, then select **Project > Preprocess** from the main menu bar. A new window opens to show the preprocessed file.

---

## Disassembling

To disassemble a compiled or ELF file of your project, select the file's name in the project window, then select **Project > Disassemble**. In order to add an ELF file to the project view for disassembly, in Windows Explorer, point to the ELF file and drag it to the project in the CodeWarrior IDE. Right click on the file name and select disassemble.



## Getting Started

### *CodeWarrior Development Process*

---

After disassembling the file, the CodeWarrior IDE creates a `.dump` file that contains the disassembled file's object code in assembly format, and debugging information in Debugging With Attribute Record Format (DWARF). The `.dump` file's contents appear in a new window.

# Application Tutorial

---

This chapter takes you through the CodeWarrior™ IDE programming environment. This tutorial does not teach you programming. It instead teaches you how to use the CodeWarrior IDE to write and debug applications for a target platform.

The examples in this chapter have been chosen for MCF5208-based code development. If you are using a different ColdFire processor, you will need to substitute the appropriate device name in the examples. Also, this tutorial assumes that debugging will be done using CCS-SIM instead of real hardware. See [Remote Debugging Panel](#) for details on connecting to a physical target evaluation board (EVB).

If you are using an EVB, then before you start this tutorial, you should configure the hardware. Typically, this entails:

- Verifying all jumper-header and switch settings,
- Connecting the EVB to your computer, and
- Connecting EVB power.

---

**NOTE** For complete setup instructions, see the EVB's own documentation.

---

This chapter consists of these sections:

- [Create a Project](#)
- [Build the Project](#)
- [Debug the Application](#)

## Create a Project

This section shows how to use stationery to create a new project for a ColdFire EVB, and how to set up the project to make a standalone application. Follow these steps:

1. Select **Programs > Freescale CodeWarrior > CodeWarrior for ColdFire V6.3 > CodeWarrior IDE**. The CodeWarrior IDE starts and the main window ([Figure 3.1](#)) appears.
2. From the main menu bar, select **File > New**. A **New** dialog box ([Figure 3.2](#)) appears.
  - a. Select **ColdFire Stationery**.
  - b. In the **Project name** text box, type MyProj.

## Application Tutorial

### Create a Project

**NOTE** The default project location is the CodeWarrior installation directory. For example, if the project name is **abc** and the installation directory is CodeWarrior\_Dir, the default location is CodeWarrior\_Dir\abc. For a different location, click the **Set** button, then use the subsequent dialog box to specify the location. Clicking **OK** returns you to the **New** dialog box.

- c. Click **OK**. The **New Project** dialog box ([Figure 3.3](#)) appears.

**Figure 3.1 CodeWarrior IDE Main Window**

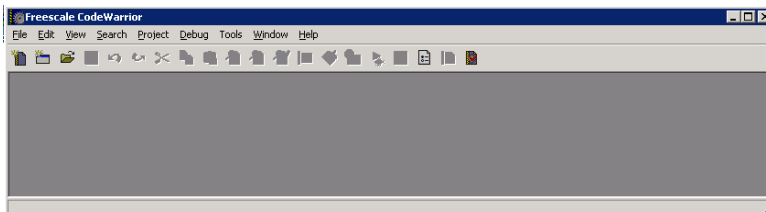

**Figure 3.2 New Dialog Box**

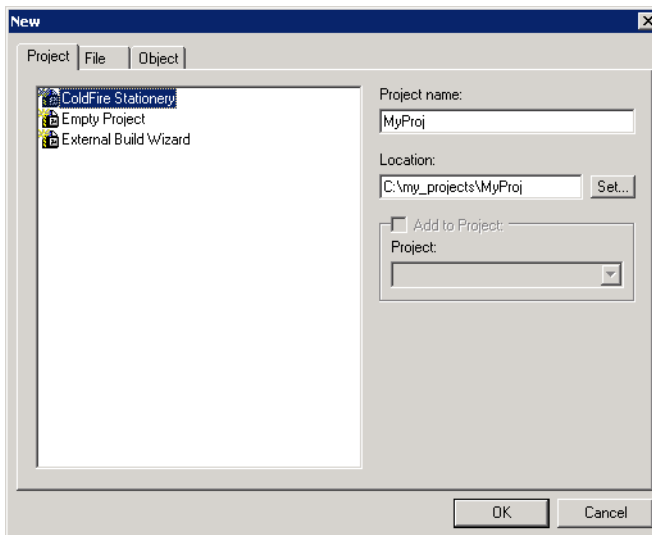
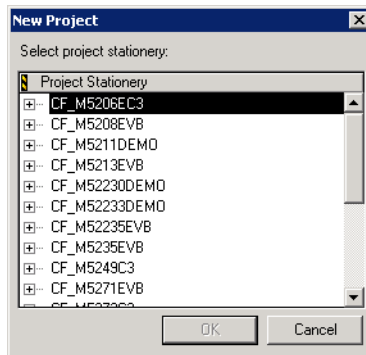
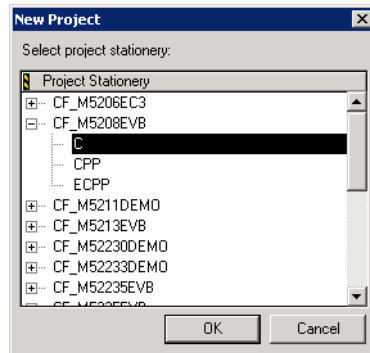

Figure 3.3 New Project Dialog Box



3. Specify CF\_M5208EVB C stationery.
  - a. Click the CF\_M5208EVB expand control — the tree structure displays the subordinate option C.
  - b. Select C, as [Figure 3.4](#) shows.

Figure 3.4 New Project Dialog Box: Selecting M5208 C Stationery



**NOTE** Many possible ColdFire target processors have an external bus, so can use large external RAM devices for debugging applications during development. But M5211, M5212, and M5213 processors do not have an external bus, so must accommodate applications in on-chip memory. Although this on-chip RAM accommodates CodeWarrior stationery, it probably is too small for full development of your application. Accordingly, for these processors, you should locate your applications in flash memory. (The [Flash Programmer](#) subsection explains how to program a flash device.)

## Application Tutorial

### Create a Project

---

- c. Click **OK**. The CodeWarrior IDE creates a new project consisting of the folders and files (header, initialization, common, and so forth) that the M5208 C stationery specifies. The project window ([Figure 3.5](#)) appears.

**Figure 3.5 Project Window**

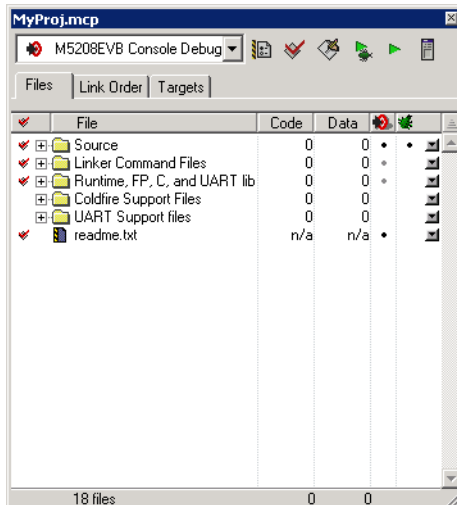

4. Make sure that the target field (immediately under the project-window tab) specifies M5208EVB Console Debug.

---

**NOTE** Files in the *project data folder* include information about the project file, various target settings, and object code. Do not change the contents of this folder, or the CodeWarrior IDE could lose project settings.

---

5. This completes project creation. You are ready to build the project, per the procedure of the next section.

---

**NOTE** While your source file (`main.c`) is open in the editor window, you can use all editor features to work with your code. If you wish, you can use a third-party editor to create and edit your code, provided that this editor saves the file as plain text. For information about the editor window, touching files, and file synchronization, and removing/adding text files, see *IDE User's Guide*.

---



## Build the Project

This section shows how to select the linker, set up remote debugging, and build (compile and link) your project.

**NOTE** The stationery for this project includes a default setup for the linker specific to the application's target platform.

Follow these steps:

1. Select the appropriate linker.
  - a. Select **Edit > Target Settings** (where *Target* is the name of the current build target). The **Target Settings** window ([Figure 3.6](#)) appears.

**NOTE** In this tutorial, the name of the build target is *M5208EVB Console Debug*. So the Target Settings window title is *M5208EVB Console Debug Settings*.

**Figure 3.6 Target Settings Window: Target Settings Panel**

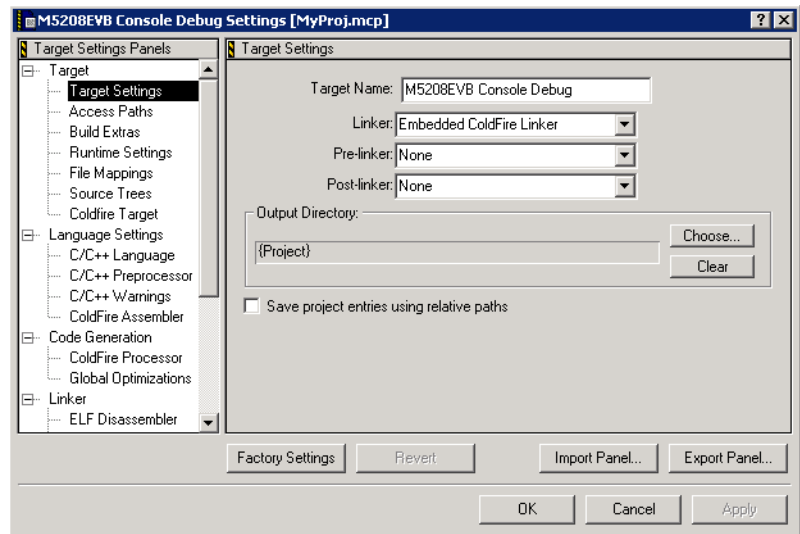

- b. From the **Target Settings Panels** list, select **Target Settings**.  
The **Target Settings** panel moves to the front of the window.
- c. Use the **Linker** list box to specify the Embedded ColdFire Linker.
- d. Click **Apply**. The IDE saves the new linker setting for the build target.

**NOTE** This linker change applies only to the current build target. To use a different build target, you must specify its appropriate linker.

For an actual target board, instead of the simulator, you would need to make board connections by this point.

2. Set Up Remote Debugging.
  - a. From the **Target Settings Panels** list, select **Remote Debugging**.  
 The **Remote Debugging** settings panel moves to the front of the **Target Settings** window, as [Figure 3.7](#) shows.

**Figure 3.7 Target Settings Window: Remote Debugging Panel**

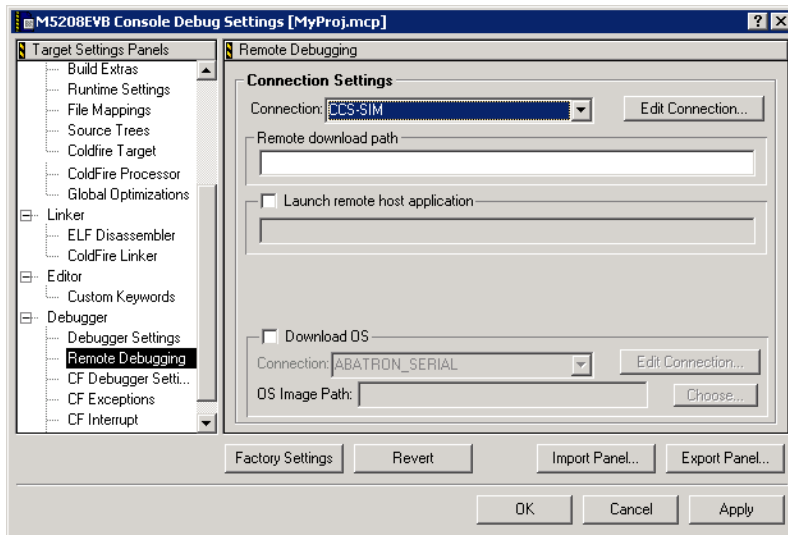

- b. Use the Connection list box to specify **CCS-SIM**.
  - c. Click **OK**. The IDE completes the remote debugging setup, and the **Target Settings** window closes.
3. From the main menu bar, select **Project > Make**. The IDE updates all files, links code into the finished application, and displays any error messages or warnings in the **Errors & Warnings** window.

**NOTE** The **Make** command applies to all source files: the IDE opens them all, the compiler generates object code, then the linker creates an executable file. (The **Compile** command applies only to selected files. The **Bring Up To Date**

command compiles all changed files, without linking.)  
The Project window lets you view compiler progress, or stop the build.

4. This completes building your project. You are ready for the debugging procedure of the next section.

## Debug the Application

This section explains you how to test whether your application runs as you expect. Topics include starting the debugger, setting a breakpoint, and viewing registers. Follow these steps:

1. Set debugger preferences.
  - a. Select **Edit > Target Settings**, (where *Target* is the name of the current build target). The **Target Settings** window appears.
  - b. From the **Target Settings Panels** list, select **CF Debugger Settings**. The **CF Debugger Settings** panel moves to the front of the window, as [Figure 3.8](#) shows.

**Figure 3.8 The CF Debugger Settings Panel**

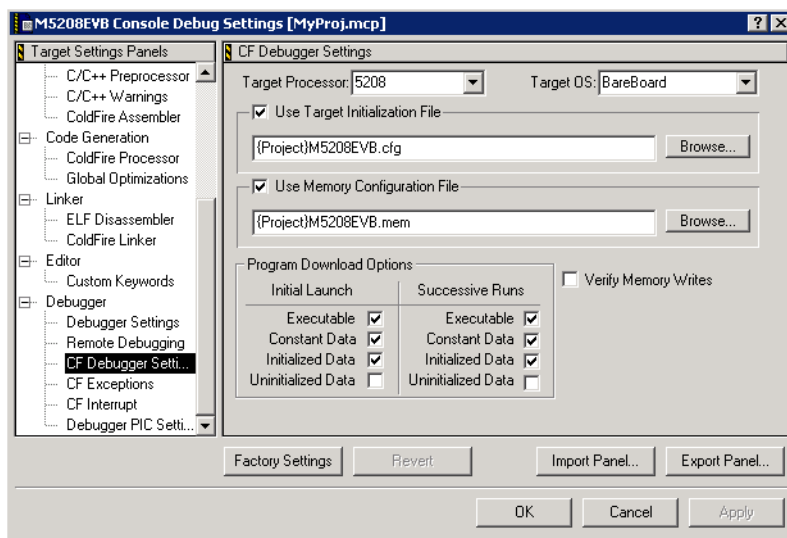

- c. Make sure that the **Target Processor** list box specifies **5208** (or the platform target you have specified).
- d. Make sure that the **Target OS** list box specifies **BareBoard**.

## Application Tutorial

### Debug the Application

- e. Click **OK**. The IDE saves the debugger settings, and the **Target Settings** window closes.

**NOTE** The default target initialization and memory configuration files are in subdirectory `\E68K_Support\Initialization_Files`, of the CodeWarrior installation directory.

2. From the IDE main menu, select **Project > Debug**. A progress bar appears as the system downloads the output file to the target. The debugger starts; the **Debugger** window ([Figure 3.9](#)) appears.

**NOTE** For a ROM build target, you must load the application to Flash memory before you can perform Step 2.

**Figure 3.9 Debugger Window**

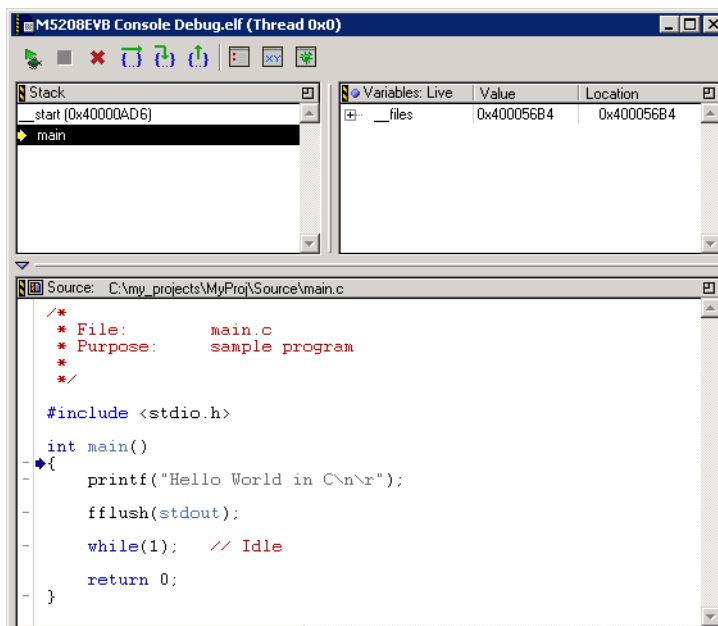

- a. Note the toolbar at the top of the window; it includes command buttons **Run**, **Stop**, **Kill**, **Step Over**, **Step Into**, and **Step Out**.
- b. Note the **Stack** pane, at the upper left. This pane shows the function calling stack.
- c. Note the **Variables** pane, at the upper right. This pane lists the names and values of any local variables.

- d. Note the **Source** pane, the largest pane of the window. This pane displays C/C++ or assembly source code.
3. Set a breakpoint.
    - a. In the **Source** pane, find the line containing the open brace ( { ) character.
    - b. In the far left-hand column of this line, click the grey dash. A red circle replaces the dash, indicating that the debugger set a breakpoint at the location. [Figure 3.10](#) shows the red-circle indicator.

**Figure 3.10** Setting a breakpoint

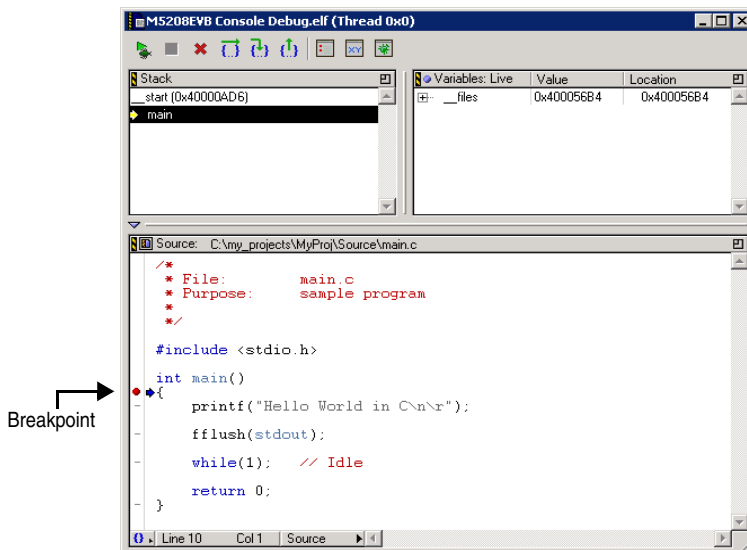

4. View registers.
  - a. From the main menu bar, select **View > Registers**. The **Registers** window ([Figure 3.11](#)) appears.
  - b. Use the expand controls to drill down through register categories to individual registers — when you reach individual registers, their values appear at the right side of the window.
  - c. You may edit register values directly in the **Registers** window.
  - d. Close the **Registers** window.

**Figure 3.11 Registers Window**

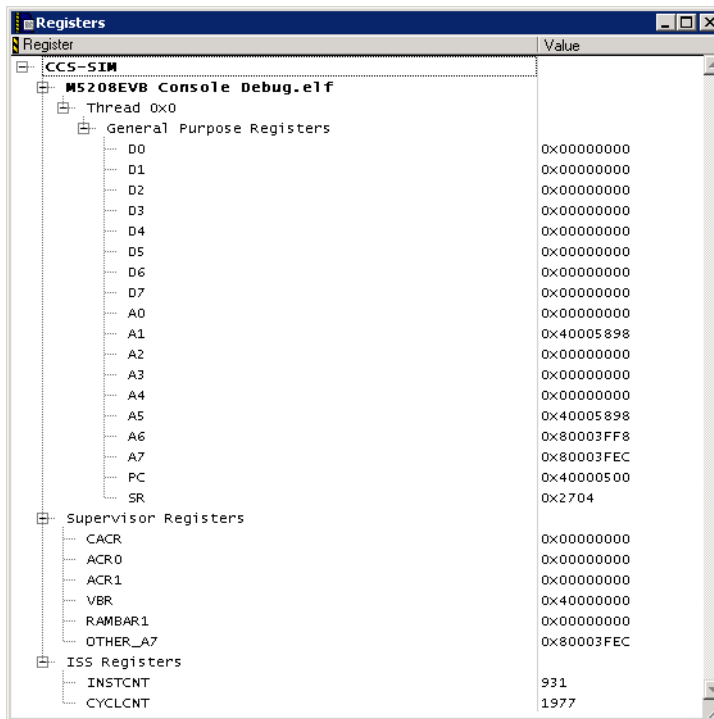

5. View memory.
  - a. In the **Source** pane of the **Debugger** window, right-click on main. The view-memory context menu ([Figure 3.12](#)) appears.

**Figure 3.12 View Memory Context Menu**

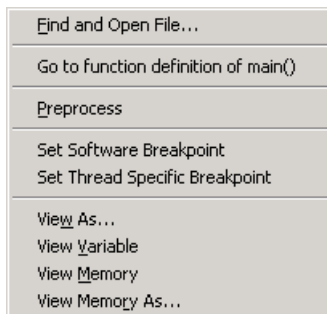

- b. From this context menu, select **View Memory**. The **View Memory** window [Figure 3.13](#) appears.

**Figure 3.13 View Memory Window**

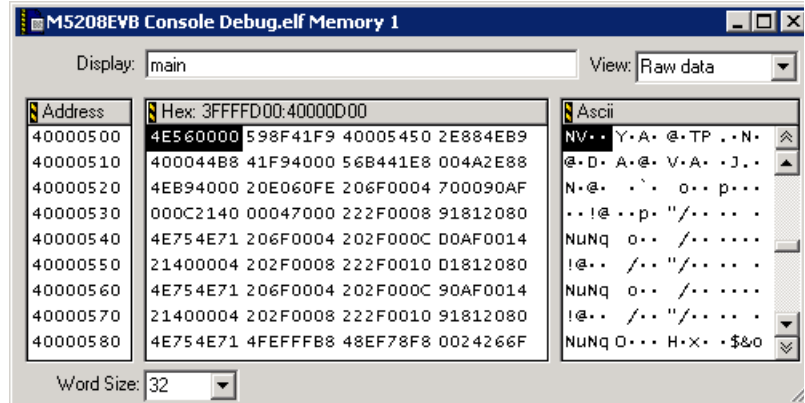

- c. Note that the **View Memory** window displays hexadecimal and ascii values for several addresses, starting at the address of `main`.
- d. In the **Display** text box, type a valid address in RAM or ROM.
- e. Press the Enter key. Window contents change, to display memory values starting at the address you entered.

**NOTE** You can edit the contents of the View Memory window. This window also lets you disassemble a random part of memory.

- f. Close the **View Memory** window.
6. Run the application.

## Application Tutorial

### Debug the Application

---

- a. From the main menu bar, select **Project > Run**, or click the **Run** button  of the **Debugger** window. A console window ([Figure 3.14](#)) appears, displaying the *Hello-World*-message result of the application.

**Figure 3.14 Console Window**

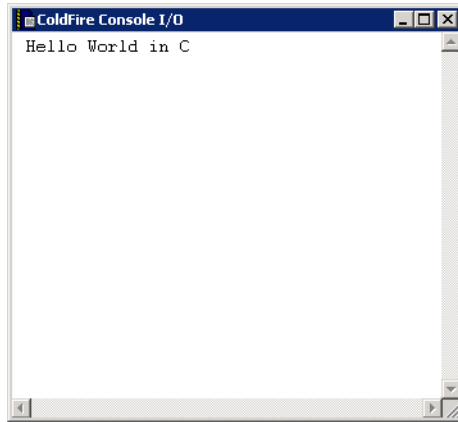

- b. Click the **Kill** button  of the **Debugger** window. The debugger stops the application, the IDE stops the debugger, and the Debugger window closes.
- c. This completes the procedure — you have created and debugged a simple application. You may close any open windows.



# Target Settings

---

This chapter explains the settings panels specific to ColdFire software development. Use the elements of these panels to control assembling, compiling, linking, and other aspects of code generation.

---

**NOTE** For documentation of the target settings panels included in all CodeWarrior products, see the *IDE User Guide*.

---

This chapter consists of these sections:

- [Target Settings Overview](#)
- [ColdFire Settings Panels](#)

## Target Settings Overview

A CodeWarrior project contains one or more *build targets*. A build target is a named collection of files and settings that the CodeWarrior IDE uses to generate an output file.

A build target contains all build-specific *target settings*. Target settings define:

- The files that belong to a build target.
- The behavior of the compiler, assembler, linker, and other build tools.

The build target feature lets you create different versions of your program for different purposes. For example, you might have a *debug* build target. This build target would include no optimizations so it is easy to debug. You might also have a *release* build target. This build target would be heavily optimized so it uses less memory or runs faster.

You control target settings through target settings *panels* that you access through the **Target Settings** window.

To open this window, select **Edit > Target Settings**, from the main-window menu bar. (**Target** is a target name, such as CF\_Simulator, within your CodeWarrior project.) An alternate way to bring up the **Target Settings** window is to bring the Targets page to the front of the project window, then double-click the project name.

[Figure 4.1](#) shows this Target Settings window. (The CodeWarrior IDE User's Guide explains all elements of this window.)

## Target Settings

### ColdFire Settings Panels

Use the tree listing of panels, in the Target Settings Panels pane, to display any settings panel. If necessary, click the expand control to see a category's list of panels. Clicking a panel name immediately puts that panel in the Target Settings pane.

**Figure 4.1 Target Settings Window**

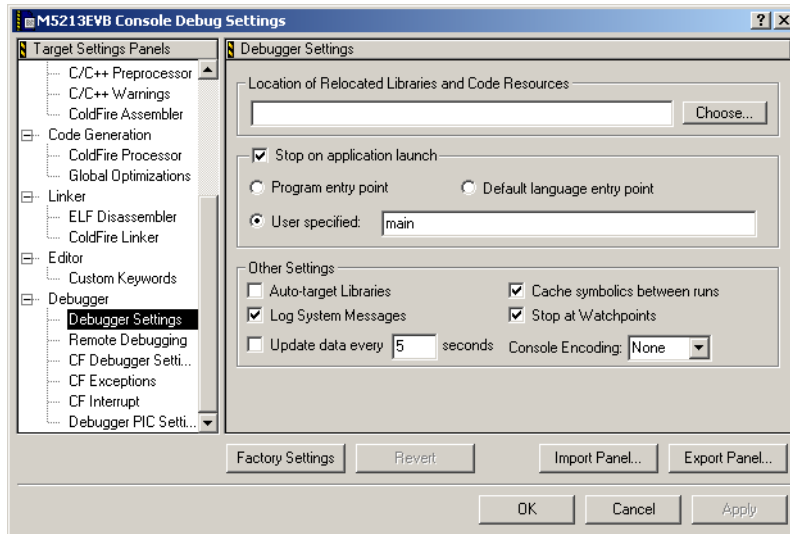

Note these buttons, at the bottom of the window:

- **Apply** — Implements your changes, leaving the *Target Settings* window open. This lets you bring up a different settings panel.
- **OK** — Implements your changes, closing the *Target Settings* window. Use this button when you make the last of your settings changes.
- **Revert** — Changes panel settings back to their most recently saved values. (Modifying any panel settings activates this button.)
- **Factory Settings** — Restores the original default values for the panel.
- **Import Panel** — Copies panel settings previously saved as an XML file.
- **Export Panel** — Saves settings of the current panel to an XML file.

## ColdFire Settings Panels

[Table 4.1](#) lists the target settings panels specific to developing applications for the ColdFire target. The following section describes these panels in detail.

**Table 4.1 ColdFire Target Settings Panels**

<a href="#">Target Settings</a>	<a href="#">ColdFire Processor</a>
<a href="#">BatchRunner PreLinker</a>	<a href="#">ELF Disassembler</a>
<a href="#">BatchRunner PostLinker</a>	<a href="#">ColdFire Linker</a>
<a href="#">ColdFire Target</a>	<a href="#">Debugger PIC Settings</a>
<a href="#">ColdFire Assembler</a>	

**NOTE** For debugger-specific panels **CF Debugger Setting**, **CF Exceptions**, **Debugger Settings**, and **Remote Debugging**, see the [Debugging](#) chapter. For information about the **C/C++ Language** and **C/C++ Warnings panels**, see the *C Compilers Reference* manual. For details on all other panels, see the *IDE User's Guide*.

## Target Settings

Use the **Target Settings** panel ([Figure 4.2](#)) to define the build target and select the appropriate linker. [Table 4.2](#) explains the elements of this panel.

**NOTE** You must use this settings panel to select a linker before you can specify the compiler, linker settings, or any other project details.

**Figure 4.2 Target Settings Panel**

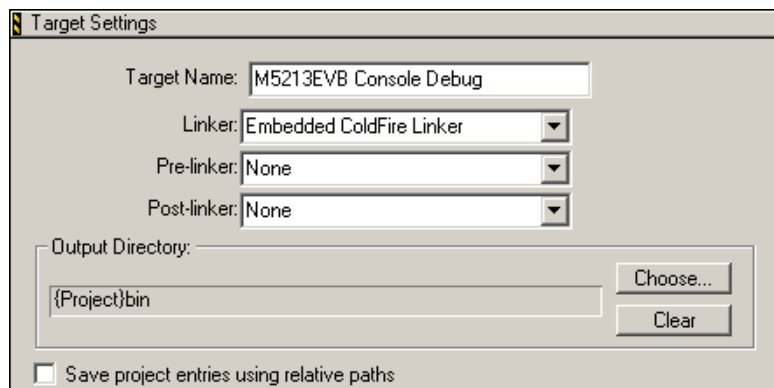

## Target Settings

### ColdFire Settings Panels

**Table 4.2 Target Settings Panel Elements**

Element	Purpose	Comments
Target Name text box	Specifies the name of the build target; this name appears subsequently on the Targets page of the project window.	Default: None.  This build-target name is <i>not</i> the name of your final output file.
Linker list box	Specifies the linker: Select <b>ColdFire</b> .	Default: ColdFire.  Controls visibility of other relevant panels.
Pre-linker list box	Specifies the pre-linker that performs work on object code before linking.	Default: None.  If your project includes Flash programming, select BatchRunner PreLinker. For more information, see <a href="#">BatchRunner PreLinker</a> .
Post-linker list box	Specifies the post-linker that performs additional work on the final executable.	Default: None.  Post-linking often includes object code format conversion. If your project includes Flash programming, select BatchRunner PostLinker. For more information, see <a href="#">BatchRunner PostLinker</a> .
Output Directory text box	Specifies the directory for the final linked output file. To specify a non-default directory, click the <b>Choose</b> button. To clear this text box, click the <b>Clear</b> button.	Default: Directory that contains the project file.
Save project entries using relative paths checkbox	Clear — Specifies minimal file searching; each project file must have a unique name.  Checked — Specifies relative file searching; project may include two or more files that have the same name.	Default: Clear.

## BatchRunner PreLinker

The **BatchRunner PreLinker** settings panel ([Figure 4.3](#)) lets you run a batch file before the IDE begins linking your project. To specify such a batch file, click the **Choose** button, then use the subsequent dialog box to navigate to and select the file. Clicking the **OK** button of the dialog box returns you to this panel, filling in the name of the batch file.

**Figure 4.3 BatchRunner PreLinker Panel**

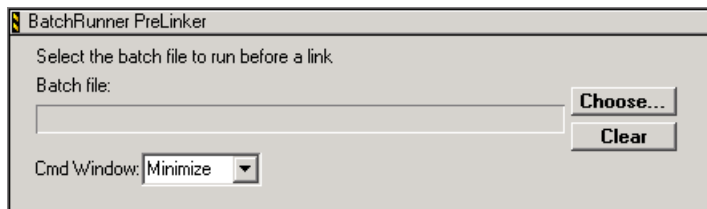

## BatchRunner PostLinker

The **BatchRunner PostLinker** settings panel ([Figure 4.4](#)) lets you run a batch file *after* the IDE builds your project. To specify such a batch file, click the **Choose** button, then use the subsequent dialog box to navigate to and select the file. Clicking the **OK** button of the dialog box returns you to this panel, filling in the name of the batch file.

**Figure 4.4 BatchRunner PostLinker Panel**

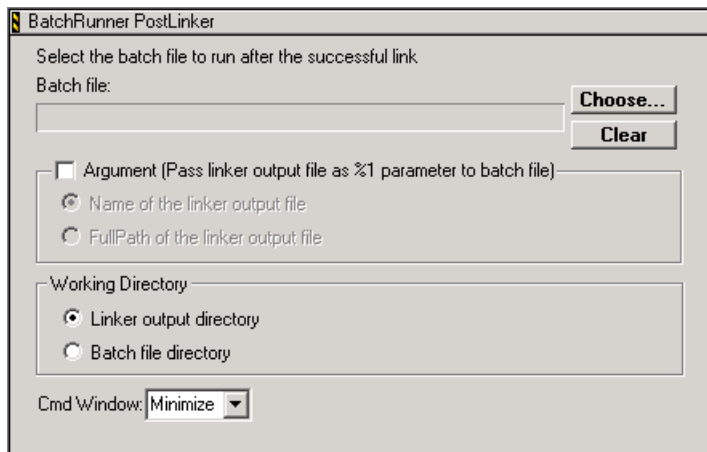

To pass the name of the output file as a parameter to the batch file, check the **Pass linker output file as %1 parameter to batch file** checkbox.

## ColdFire Target

Use the **ColdFire Target** panel ([Figure 4.5](#)) to specify the type of project file and to name your final output file. [Table 4.3](#) explains the elements of this panel. (To create alternative builds, compiling for different targets, use the `__option()` pre-processor function with conditional compilation.)

**Figure 4.5 ColdFire Target Panel**

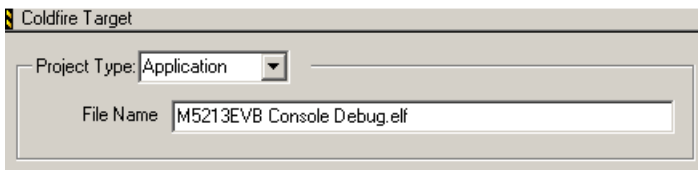

**Table 4.3 ColdFire Target Panel Elements**

Element	Purpose	Comments
Project Type list box	Specifies the kind of project: Application — executable project Library — static library Shared Library — shared library	Default: Application.
File Name text box	Specifies the name of your final linked output file.	Default: None. Convention: use extension.elf for an application, .lib or .a for a library.

## ColdFire Assembler

Use the **ColdFire Assembler** panel ([Figure 4.6](#)) to control the source format or syntax for the CodeWarrior assembler, and to specify the target processor, for which you are generating code. [Table 4.4](#) explains the elements of this panel.

**Figure 4.6 ColdFire Assembler Panel**

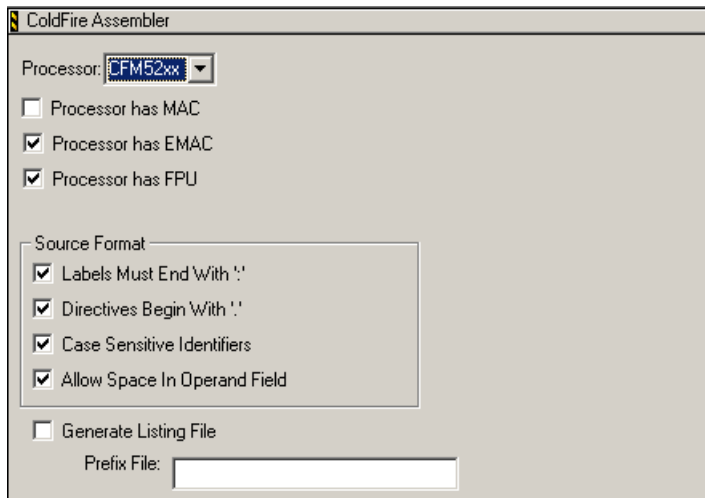

**Table 4.4 ColdFire Assembler Panel Elements**

Element	Purpose	Comments
Processor list box	Specifies the target processor.	Default: MCF52xx.
Processor has MAC checkbox	Clear — Tells assembler that the target processor does <i>not</i> have a multiply accumulator (MAC) unit. Checked — Tells assembler that the target processor <i>does</i> have a MAC.	Default: Clear. You can check both the MAC and EMAC checkboxes.
Processor has EMAC checkbox	Clear — Tells assembler that the target processor does <i>not</i> have an enhanced multiply accumulator (EMAC) unit. For more information, see the reference manual at {CodeWarrior_Dir} \Freescale_Documentation, Checked — Tells assembler that the target processor <i>does</i> have EMAC.	Default: Clear. You can check both the MAC and EMAC checkboxes.

## Target Settings

### ColdFire Settings Panels

**Table 4.4 ColdFire Assembler Panel Elements (*continued*)**

Element	Purpose	Comments
Processor has FPU checkbox	<p>Clear — Tells assembler that the target processor does <i>not</i> have a floating-point unit (FPU).</p> <p>Checked — Tells assembler that the target processor <i>does</i> have an FPU.</p>	Default: Clear
Labels Must End With ':' checkbox	<p>Clear — System does <i>not</i> require labels to end with colons.</p> <p>Checked — System <i>does</i> require labels to end with colons.</p>	Default: Checked.
Directives Begin With '.' checkbox	<p>Clear — System does <i>not</i> require directives to start with periods.</p> <p>Checked — System <i>does</i> require directives to start with periods.</p>	Default: Checked.
Case Sensitive Identifiers checkbox	<p>Clear — Tells assembler to ignore case in identifiers.</p> <p>Checked — Tells assembler to consider case in identifiers.</p>	Default: Checked.
Allow Space In Operand Field checkbox	<p>Clear — Tells assembler to <i>not</i> allow spaces in operand fields.</p> <p>Checked — Tells assembler to <i>allow</i> spaces in operand fields.</p>	Default: Checked.



**Table 4.4 ColdFire Assembler Panel Elements (continued)**

Element	Purpose	Comments
Generate Listing File checkbox	Clear — Tells assembler to <i>not</i> generate a listing file.  Checked — Tells assembler to <i>generate</i> a listing file.	Default: Clear.  A listing file contains the file source, along with line numbers, relocation information, and macro expansions.
Prefix File text box	Specifies the name of the assembly prefix file.	Default: None.  Useful for include files that define common constants, global declarations, and function names. Otherwise, the assembler's default prefix file suffices.

## ELF Disassembler

Use the **ELF Disassembler** panel ([Figure 4.7](#)) to control settings for the disassembly view; you see this view when you disassemble object files. [Table 4.5](#) explains the elements of this panel.

## Target Settings

### ColdFire Settings Panels

Figure 4.7 ELF Disassembler Panel

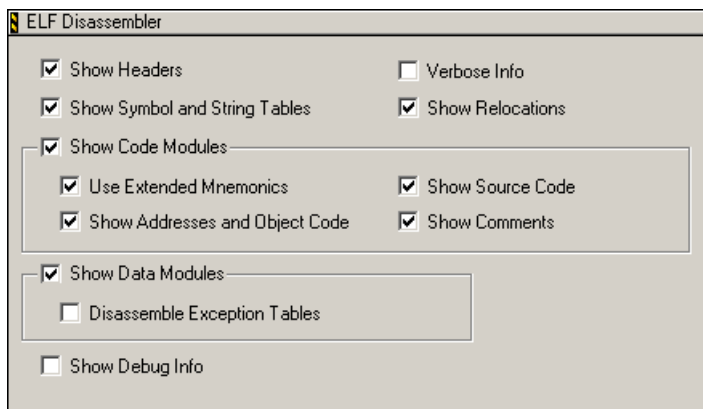

Table 4.5 ELF Disassembler Panel Elements

Element	Purpose	Comments
Show Headers checkbox	<p>Clear — Keeps ELF header information <i>out</i> of the disassembled output.</p> <p>Checked — Puts ELF header information <i>into</i> the disassembled output.</p>	Default: Checked.
Verbose Info checkbox	<p>Clear — Uses minimum information in disassembled output.</p> <p>Checked — Puts additional information <i>into</i> the disassembled output.</p>	<p>Default: Clear.</p> <p>For the <code>.symtab</code> section, additional information includes numeric equivalents for descriptive constants. For the <code>.line</code>, <code>.debug</code>, <code>.extab</code>, and <code>.extabindex</code> sections, additional information includes an unstructured hex dump.</p>
Show Symbol and String Tables checkbox	<p>Clear — Keeps symbol table <i>out</i> of the disassembled module.</p> <p>Checked — Puts symbol table <i>into</i> the disassembled module.</p>	Default: Checked.

**Table 4.5 ELF Disassembler Panel Elements (continued)**

Element	Purpose	Comments
Show Relocations checkbox	<p>Clear — Keeps relocation information <i>out</i> of the disassembled module.</p> <p>Checked — Puts relocation information <i>into</i> the disassembled module.</p>	<p>Default: Checked.</p> <p>Relocation information pertains to the <code>.real.text</code> and <code>.reala.data</code> sections.</p>
Show Code Modules checkbox	<p>Clear — Keeps any of the four types of ELF code sections <i>out</i> the disassembled module; disables the four subordinate checkboxes.</p> <p>Checked — Activates the four subordinate checkboxes. For each checked subordinate checkbox, puts ELF code section <i>into</i> the disassembled module.</p>	<p>Default: Checked.</p>
Use Extended Mnemonics checkbox	<p>Clear — Keeps extended mnemonics <i>out</i> of the disassembled module.</p> <p>Checked — Puts instruction extended mnemonics <i>into</i> the disassembled module.</p>	<p>Default: Checked.</p> <p>This checkbox is active only if the Show Code Modules checkbox is checked.</p>
Show Source Code checkbox	<p>Clear — Keeps source code <i>out</i> of the disassembled module.</p> <p>Checked — Lists source code <i>in</i> the disassembled module. Display is mixed mode, with line-number information from original C source code.</p>	<p>Default: Checked.</p> <p>This checkbox is active only if the Show Code Modules checkbox is checked.</p>

## Target Settings

### ColdFire Settings Panels

**Table 4.5 ELF Disassembler Panel Elements (*continued*)**

Element	Purpose	Comments
Show Addresses and Object Code checkbox	<p>Clear — Keeps addresses and object code <i>out</i> of the disassembled module.</p> <p>Checked — Lists addresses and object code <i>in</i> the disassembled module.</p>	<p>Default: Checked.</p> <p>This checkbox is active only if the Show Code Modules checkbox is checked.</p>
Show Comments checkbox	<p>Clear — Keeps disassembler comments <i>out</i> of the disassembled module.</p> <p>Checked — <i>Shows</i> disassembler comments in sections that have comment columns.</p>	<p>Default: Checked.</p> <p>This checkbox is active only if the Show Code Modules checkbox is checked.</p>
Show Data Modules checkbox	<p>Clear — Blocks output of ELF data sections for the disassembled module; disables the Disassemble Exception Tables checkbox.</p> <p>Checked — Outputs <code>.rodata</code>, <code>.bss</code>, or other such ELF data sections in the disassembled module. Activates the Disassemble Exception Tables checkbox.</p>	<p>Default: Checked.</p>
Disassemble Exception Tables checkbox	<p>Clear — Keeps C++ exception tables <i>out</i> of the disassembled module.</p> <p>Checked — Includes C++ exception tables <i>in</i> the disassembled module.</p>	<p>Default: Clear.</p> <p>This checkbox is active only if the Show Data Modules checkbox is checked.</p>
Show Debug Info checkbox	<p>Clear — Keeps DWARF symbolics <i>out</i> of the disassembled module.</p> <p>Checked — Includes DWARF symbolics <i>in</i> the disassembled module.</p>	<p>Default: Clear.</p>

## ColdFire Processor

Use the **ColdFire Processor** panel ([Figure 4.8](#)) to control code-generation settings. [Table 4.6](#) explains the elements of this panel.

**Figure 4.8 ColdFire Processor Panel**

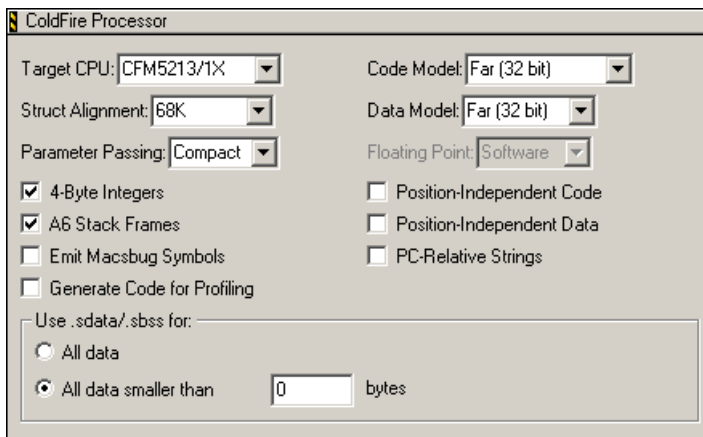

**Table 4.6 ColdFire Processor Panel Elements**

Element	Purpose	Comments
Target CPU list box	Specifies the target ColdFire processor.	Default: MCF5282.
Code Model list box	Specifies access addressing for data and instructions in the object code:  Smart — Relative (16-bit) for function calls in the same segment; otherwise absolute (32-bit).  Near (16 bit) — Relative for all function calls.  Far (32 bit) — Absolute for all function calls.	Default: Far (32 bit).  Far is useful if your source file generates more than 32K of code, or if there is an out-of-range link error message.  Near requires adjusting the <code>.lcf</code> . For <code>.lcf</code> information, see the <i>ColdFire Build Tools Reference manual</i> .

## Target Settings

### ColdFire Settings Panels

**Table 4.6 ColdFire Processor Panel Elements (continued)**

Element	Purpose	Comments
Struct Alignment list box	<p>Specifies record and structure alignment in memory:</p> <p>68K 2-byte — Aligns all fields on 2-byte boundaries, except for fields of only 1 byte.</p> <p>68K 4-byte — Aligns all fields on 4-byte boundaries.</p> <p>PowerPC 1-byte — Aligns each field on its natural boundary.</p>	<p>Default: 68k 4-byte.</p> <p>This panel element corresponds to the <code>options align</code> pragma.</p> <p>Natural-boundary alignment means 1-byte for a 1-byte character, 2-bytes for a 16-bit integer, and so on.</p> <p>NOTE: When you compile and link, alignment should be the same for all files and libraries.</p>
Data Model list box	<p>Specifies global-data storage and reference:</p> <p>Far (32 bit) — Storage in far data space; available memory is the only size limit.</p> <p>Near (16 bit) — Storage in near data space; size limit is 64K.</p>	<p>Default: Far (32 bit).</p> <p>This panel element corresponds the <code>far_data</code> pragma.</p>
Parameter Passing list box	<p>Specifies parameter-passing level:</p> <p>Compact — Passes on even-sized boundary for parameters smaller than <code>int</code> (2 for short and char).</p> <p>Standard — Like compact, but always padded to 4 bytes.</p> <p>Register — Passes in scratch registers D0 — D2 for integers, A0 — A1 for pointers and fp0 — fp1 when FPU codegen is selected; this can speed up programs that have many small functions.</p>	<p>Default: Compact.</p> <p>These levels correspond to the <code>compact_abi</code>, <code>standard_abi</code>, and <code>register_abi</code> pragmas.</p> <p>NOTE: Be sure that all called functions have prototypes. When you compile and link, parameter passing should be the same for all files and libraries.</p>

**Table 4.6 ColdFire Processor Panel Elements (continued)**

Element	Purpose	Comments
Floating Point list box	Specifies handling method for floating-point operations:  Software — C runtime library code emulates floating-point operations.  Hardware — Processor hardware performs floating point operations; only appropriate for processors that have floating-point units.	Default: Software.  For software selection, your project must include the appropriate <code>FP_ColdFire</code> C runtime library file.  Greyed out if your target processor lacks an FPU.
4-Byte Integers checkbox	Clear — Specifies 2-byte integers.  Checked — Specifies 4-byte integers.	Default: Checked.
Position-Independent Code checkbox	Clear — Generates relocatable code.  Checked — Generates position-independent code (PIC) that is non-relocatable.	Default: Clear.  PIC is available with 16- and 32-bit addressing.
A6 Stack Frames checkbox	Clear — Disables call-stack tracing; generates faster and smaller code.  Checked — Enables call-stack tracing; each stack frame sets up and restores register A6.	Default: Checked.  Checking this checkbox corresponds to using the <code>a6frames</code> pragma.
Position-Independent Data checkbox	Clear — Generates relocatable data.  Checked — Generates position-independent data (PID) that is non-relocatable.	Default: Clear.  PID is available with 16- and 32-bit addressing.
Emit Macsbug Symbols checkbox	Clear — Does <i>not</i> generate Macsbug symbols.  Checked — Generates Macsbug symbols inside code after RTS statements.	Default: Clear.  A Macsbug symbol is the routine name, appended after the routine, in Pascal format. These symbols are appropriate only for older debuggers.

## Target Settings

### ColdFire Settings Panels

**Table 4.6 ColdFire Processor Panel Elements (continued)**

Element	Purpose	Comments
PC-Relative Strings checkbox	<p>Clear — Does <i>not</i> use program-counter relative addressing for storage of function local strings.</p> <p>Checked — <i>Does</i> use program-counter relative addressing for storage of function local strings.</p>	<p>Default: Clear.</p> <p>Checking this box corresponds to using the <code>pcrelstrings</code> pragma.</p>
Generate code for profiling	<p>Checked — Has the processor generate code for use with a profiling tool.</p> <p>Clear — Prevents the processor from generating code for use with a profiling tool.</p>	<p>Default: Clear.</p> <p>Checking this box corresponds to using the command-line option <code>-profile</code>.</p> <p>Clearing this checkbox is equivalent to using the command-line option <code>-noprofile</code></p>
Use <code>.sdata/.sbss</code> for area	<p>All data — Select this option button to store all data items in the small data address space.</p> <p>All data smaller than — Select this option button to specify the maximum size for items stored in the small data address space; enter the maximum size in the text box.</p>	<p>Default: All data smaller than/0.</p> <p>Using the small data area speeds data access, but has ramifications for the hardware memory map. The default settings specify <i>not</i> using the small data area.</p>

## ColdFire Linker

Use the **ColdFire Linker** panel ([Figure 4.9](#)) to control the final form of your object code. [Table 4.7](#) explains the elements of this panel.



**Figure 4.9 ColdFire Linker Panel**

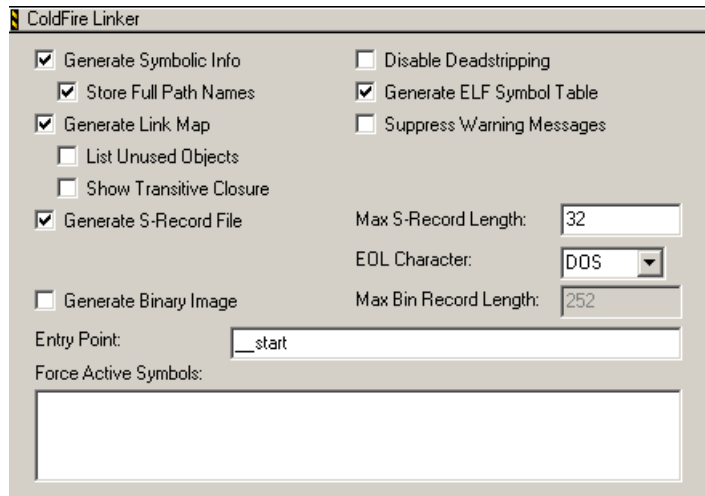

**Table 4.7 ColdFire Linker Panel Elements**

Element	Purpose	Comments
Generate Symbolic Info checkbox	<p>Clear — Does <i>not</i> generate debugging information in the output ELF file.</p> <p>Checked — Puts generated debugging information into the output ELF file.</p>	Default: Checked.
Store Full Path Names checkbox	<p>Clear — In debugging information in the linked ELF file, uses only names of source files.</p> <p>Checked — Includes source-file paths in the debugging information in the linked ELF file.</p>	<p>Default: Checked.</p> <p>Clearing this checkbox saves target memory, but increases the time the debugger needs to find the source files.</p>

## Target Settings

### ColdFire Settings Panels

**Table 4.7 ColdFire Linker Panel Elements (continued)**

Element	Purpose	Comments
Generate Link Map checkbox	<p>Clear — Does <i>not</i> generate a link map.</p> <p>Checked — Does generate a link map (a text file that identifies definition files for each object and function of your output file); activates the List Unused Objects and Show Transitive Closure checkboxes.</p>	<p>Default: Checked.</p> <p>A link map includes addresses of all objects and functions, a memory map of sections, and values of symbols the linker generates. A link map has the same filename as the output file, but with extension <code>.xMAP</code>.</p>
List Unused Objects checkbox	<p>Clear — Does <i>not</i> include unused objects in the link map.</p> <p>Checked — Does include unused objects in the link map.</p>	<p>Default: Clear.</p> <p>This checkbox is active only if the Generate Link Map checkbox is checked.</p> <p>NOTE: The linker never deadstrips unused assembler relocatables or relocatables built with a non-CodeWarrior compiler. But checking this checkbox gives you a list of such unused items; you can use this list to remove the symbols.</p>
Show Transitive Closure checkbox	<p>Clear — Does <i>not</i> include the link map objects that <code>main()</code> references.</p> <p>Checked — Recursively lists in the link map all objects that <code>main()</code> references.</p>	<p>Default: Checked.</p> <p>This checkbox is active only if the Generate Link Map checkbox is checked. Listings after this table show the effect of this checkbox.</p>
Disable Deadstripping checkbox	<p>Clear — Lets linker remove unused code and data.</p> <p>Checked — Prevents the linker from removing unused code or data.</p>	<p>Default: Clear.</p>

**Table 4.7 ColdFire Linker Panel Elements (continued)**

Element	Purpose	Comments
Generate ELF Symbol Table checkbox	<p>Clear — Omits the ELF symbol table and relocation list from the ELF output file.</p> <p>Checked — Includes an ELF symbol table and relocation list in the ELF output file.</p>	Default: Checked.
Suppress Warning Messages checkbox	<p>Clear — Reports all linker warnings.</p> <p>Checked — Reports only fatal warning messages; does not affect display of messages from other parts of the IDE.</p>	Default: Clear.
Generate S-Record File checkbox	<p>Clear — Does not generate an S-record file.</p> <p>Checked — Generates an S3-type S-record file, suitable for printing or transportation to another computer system. Activates the Max S-Record text box and the EOL character list box.</p>	<p>Default: Checked.</p> <p>The S-record has the same filename as the executable file, but with extension <code>.S19</code>, <code>.S3</code> records include code, data, and their 4-byte addresses.</p>
Max S-Record Length text box	Specifies maximum number of bytes in S-record lines that the linker generates. The maximum value for this text box is 252.	<p>Default: 80.</p> <p>This text box is active only if the Generate S-Record File checkbox is checked.</p> <p>NOTE: Many embedded systems limit S-record lines to 24 or 26 bytes. A value of 20 to 30 bytes lets you see the S-record on a single page.</p>
EOL Character list box	Specifies the end-of-line character for the S-record file, by operating system: DOS, UNIX, or MAC.	<p>Default: DOS.</p> <p>This text box is active only if the Generate S-Record File checkbox is checked.</p>

## Target Settings

### ColdFire Settings Panels

**Table 4.7 ColdFire Linker Panel Elements (continued)**

Element	Purpose	Comments
Generate Binary Image checkbox	<p>Clear — Does not create a binary version of the S-record file.</p> <p>Checked — Saves a binary version of the S-record file to the project folder; The binary file has the <code>.b</code> filename extension.</p> <p>Activates the Max Bin Record Length text box.</p>	<p>Default: Clear.</p> <p>Binary file format is address (4 bytes), byte count (4 bytes), and data bytes (variable length).</p>
Max Bin Record Length text box	<p>Specifies data-byte length for each binary record. The maximum value is 252.</p>	<p>Default: None.</p> <p>This text box is active only if the Generate Binary Image checkbox is checked.</p>
Entry Point text box	<p>Specifies the program starting point: the first function the debugger uses upon program start.</p>	<p>Default: <code>__start</code>.</p> <p>(This default function is in file <code>ColdFire__startup.c</code>. It sets up the ColdFire EABI environment before code execution. Its final task is calling <code>main()</code>.)</p>
Force Active Symbols text box	<p>Specifies symbols to be included in the output file even if not referenced; makes such symbols immune from deadstripping.</p>	<p>Default: None.</p> <p>Use spaces to separate multiples symbols.</p>

[Listing 4.1](#) and [Listing 4.2](#) show the effect of the **Show Transitive Closure** checkbox.

#### Listing 4.1 Sample Code for Transitive Closure

```
void alpha(){
    int a = 1001;
}
void alpha(){
    int b = 1002;
    alpha();
}
int main(void){
    alpha();
}
```

---

```
    return 1;
}
```

---

If you checked the **Show Transitive Closure** checkbox of the **ColdFire Linker** panel and compiled the source files,

- The linker would generate a link map file, and
- The link map file would include text such as that of [Listing 4.2](#).

---

#### Listing 4.2 Link Map: Effects of Show Transitive Closure

---

```
# Link map of __start
1] __start (func, global) found in C_4i_CF_Runtime.a E68k_startup.o
2] __main (func, global) found in main.c
3] __alpha (func, global) found in main.c
4] __alpha1 (func, global) found in main.c
```

---

## Debugger PIC Settings

Use the **Debugger PIC Settings** panel ([Figure 4.10](#)) to specify an alternate address where you want your ELF image downloaded on the target.

**Figure 4.10 Debugger PIC Settings Panel**

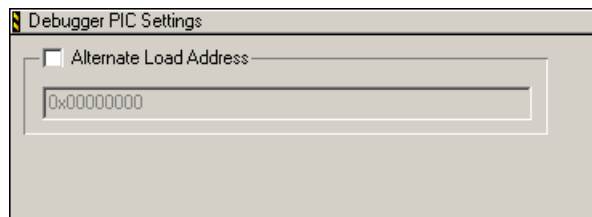

Usually, Position Independent Code (PIC) is linked so that the entire image starts at address 0x00000000. To specify a different target address for loading the PIC module:

1. Check the **Alternate Load Address** checkbox — this activates the text box.
2. Enter the address in the text box.

At download time, the debugger downloads your ELF file to this new address of the target.

---

**NOTE** The debugger does not verify that your code can execute at the new address. However, the PIC generation settings of the compiler and linker, and the startup routines of your code, correctly set any base registers and perform any appropriate relocations.

---



**Target Settings**  
*ColdFire Settings Panels*

---

# Debugging

---

This chapter explains aspects of debugging that are specific to the ColdFire architectures. For more general information about the CodeWarrior debugger, see the *IDE 5.7 User's Guide*.

To start the CodeWarrior debugger, select **Project > Debug**. The debugger window appears; the debugger loads the image file that the current build target produces. You can use the debugger to control program execution, insert breakpoints, and examine memory and registers.

---

**NOTE** The automatic loading of the previous paragraph depends on the load options you specify, and on whether your application code is in ROM or Flash memory.

---

This chapter consists of these sections:

- [Target Settings for Debugging](#)
- [Remote Connections for Debugging](#)
- [BDM Debugging](#)
- [Debugging ELF Files without Projects](#)
- [Special Debugger Features](#)

## Target Settings for Debugging

Several target settings panels control the way the debugger works:

- [CF Debugger Settings Panel](#)
- [Remote Debugging Panel](#)
- [CF Exceptions Panel](#)
- [Debugger Settings Panel](#)
- [CF Interrupt Panel](#)

To access these panels, select **Edit > Target Settings**, from the main menu bar. (*Target* is the current build target in the CodeWarrior project.) The *Target Settings* window ([Figure 5.1](#)) appears.

**Figure 5.1 Target Settings Window**

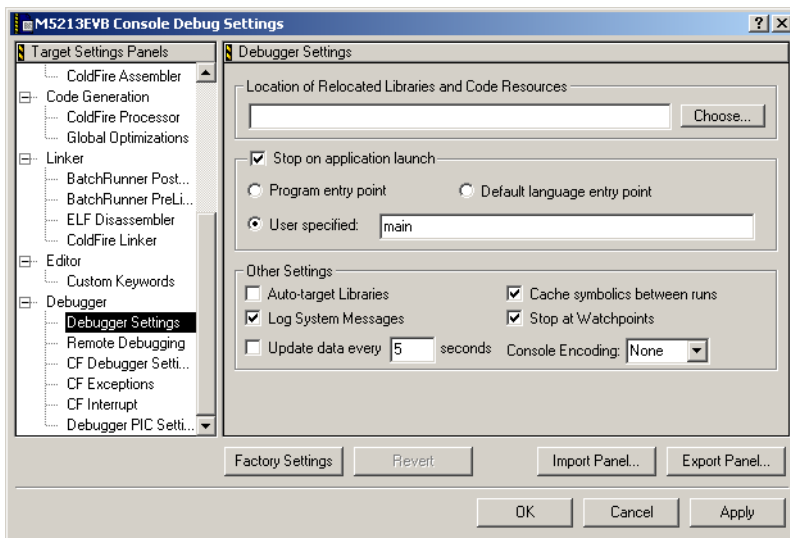

[Table 5.1](#) lists additional panels that can affect debugging.

**Table 5.1 Additional Settings Panels That May Affect Debugging**

Panel	Impact	See
C/C++ Warnings	compiler warnings	<i>C Compilers Reference</i>
ColdFire Linker	controls symbolics, linker warnings	<a href="#">ColdFire Linker</a>
ColdFire Processor	optimizations	<a href="#">ColdFire Processor</a>
Global Optimizations	optimizations	<i>IDE User's Guide</i>

## CF Debugger Settings Panel

Use the **CF Debugger Settings** panel ([Figure 5.2](#)) to select debugger hardware and control interaction with the target board. [Table 5.2](#) explains the elements of this panel.



**Figure 5.2 CF Debugger Settings Panel**

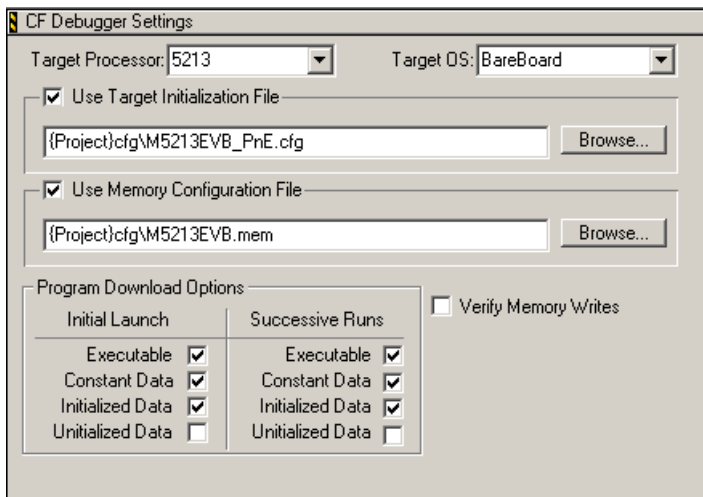

**Table 5.2 CF Debugger Settings Panel Elements**

Element	Purpose	Comments
Target Processor list box	Specifies the target processor.	Your stationary selection automatically makes this specification.
Target OS list box	Specifies a real-time operating system; for bare board development, select BareBoard.	Default: BareBoard. If you have Professional-Edition software and install an RTOS, that RTOS becomes a selection of this list box. (Special- and Standard-Edition software, however, does not support an RTOS.)
Use Target Initialization File checkbox	<p>Clear — Specifies <i>not</i> using a target initialization file; deactivates file subordinate text box and Browse button.</p> <p>Checked — Tells the debugger to use the specified target initialization file. To enter a pathname in the text box, click the Browse button, then use the file-select dialog box to specify the file.</p>	<p>Default: checked.</p> <p>The initialization file is in subdirectory <code>\E68K_Support\Initialization_Files</code>, of the CodeWarrior installation directory (or directory that contains your project). Clear this checkbox, if you are using an Abatron-based remote connection. Make sure this checkbox is checked, if you are using a P&amp;E Micro-based remote connection.</p>

## Debugging

### Target Settings for Debugging

**Table 5.2 CF Debugger Settings Panel Elements (continued)**

Element	Purpose	Comments
Use Memory Configuration File checkbox	<p>Clear — Specifies <i>not</i> using a memory configuration file; deactivates file subordinate text box and Browse button.</p> <p>Checked — Tells the debugger to use the specified memory configuration file. To enter a pathname in the text box, click the Browse button, then use the file-select dialog box to specify the file.</p>	<p>Default: Unchecked.</p> <p>The memory configuration file is in subdirectory  <code>\E68K_Support\Initialization_Files</code>, of the CodeWarrior installation directory (or directory that contains your project).</p> <p>Do not check this checkbox, if you are using a Abatron-based remote connection.</p> <p>Check this checkbox, if you are using a P&amp;E Micro-based remote connection.</p>
Initial Launch: Executable checkbox	<p>Clear — Does <i>not</i> download program executable code or text sections for initial launch.</p> <p>Checked — Downloads program executable code and text sections for initial launch.</p>	<p>Default: Checked.</p> <p>Initial launch is the first time you debug the project after you start the debugger from the IDE.</p>
Initial Launch: Constant Data checkbox	<p>Clear — Does <i>not</i> download program constant data sections for initial launch.</p> <p>Checked — Downloads program constant data sections for initial launch.</p>	<p>Default: Checked.</p> <p>Initial launch is the first time you debug the project after you start the debugger from the IDE.</p>
Initial Launch: Initialized Data checkbox	<p>Clear — Does <i>not</i> download program initialized data sections for initial launch.</p> <p>Checked — Downloads program initialized data sections for initial launch.</p>	<p>Default: Checked.</p> <p>Initial launch is the first time you debug the project after you start the debugger from the IDE.</p>
Initial Launch: Uninitialized Data checkbox	<p>Clear — Does <i>not</i> download program uninitialized data sections for initial launch.</p> <p>Checked — Downloads program uninitialized data sections for initial launch.</p>	<p>Default: Clear.</p> <p>Initial launch is the first time you debug the project after you start the debugger from the IDE.</p>

**Table 5.2 CF Debugger Settings Panel Elements (continued)**

Element	Purpose	Comments
Successive Runs: Executable checkbox	<p>Clear — Does <i>not</i> download program executable code or text sections for successive runs.</p> <p>Checked — Downloads program executable code and text sections for successive runs.</p>	<p>Default: Clear.</p> <p>Successive runs are debugging actions after initial launch. Note that rebuilding the project returns you to the initial-launch state.</p>
Successive Runs: Constant Data checkbox	<p>Clear — Does <i>not</i> download program constant data sections for successive runs.</p> <p>Checked — Downloads program constant data sections for successive runs.</p>	<p>Default: Clear.</p> <p>Successive runs are debugging actions after initial launch. Note that rebuilding the project returns you to the initial-launch state.</p> <p>NOTE: If you check this checkbox, avoid cycling board power. Doing so can prevent application rebuilding and code reloading, making debugging unnecessarily difficult.</p>
Successive Runs: Initialized Data checkbox	<p>Clear — Does <i>not</i> download program initialized data sections for successive runs.</p> <p>Checked — Downloads program initialized data sections for successive runs.</p>	<p>Default: Checked.</p> <p>Successive runs are debugging actions after initial launch. Note that rebuilding the project returns you to the initial-launch state.</p>
Successive Runs: Uninitialized Data checkbox	<p>Clear — Does <i>not</i> download program uninitialized data sections for successive runs.</p> <p>Checked — Downloads program uninitialized data sections for successive runs.</p>	<p>Default: Checked.</p> <p>Successive runs are debugging actions after initial launch. Note that rebuilding the project returns you to the initial-launch state.</p>
Verify Memory Writes checkbox	<p>Clear — Does not confirm that a section written to the target matches the original section.</p> <p>Checked — Confirms that any section written to the target matches the original section.</p>	<p>Default: Clear.</p>

## Remote Debugging Panel

Use the **Remote Debugging** panel ([Figure 5.3](#)) to set up connections for remote debugging. [Table 5.3](#) explains the elements of this panel. Text following the figure and table provides more information about adding and changing remote connections.

## Debugging

### Target Settings for Debugging

**NOTE** Special-Edition software supports the following remote connections: P&E Microsystems USB, P&E Microsystems Cyclone Max, and Freescale USB TAP. Standard-Edition software supports only P&E Microsystems USB remote connection. For any other type of remote connection, you must have Professional-Edition software.

**Figure 5.3 Remote Debugging Panel**

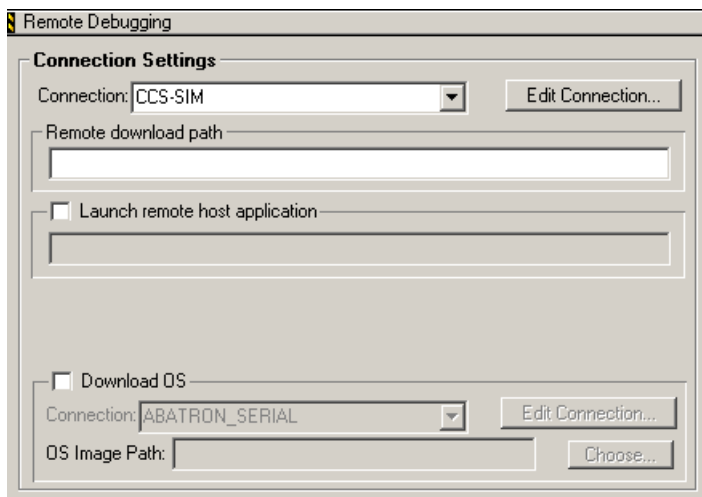

**Table 5.3 Remote Debugging Panel Elements**

Element	Purpose	Comments
Connection list box	Specifies the remote-connection type: the remote debugger, along with its default settings.	Possible remote connections include Abatron Serial or TCP/IP; CCS-SIM; and P&E Microsystems Parallel, USB, Cyclone Max, and Lightning, and Freescale USB TAP. However, you must add any such additional connection before it is available in this list box.
Edit Connection button	Starts process of adding a remote connection, or changing settings of an existing remote connection.	For instructions, see text after this table.

**Table 5.3 Remote Debugging Panel Elements (continued)**

Element	Purpose	Comments
Remote download text box	Specifies the absolute path to the directory in which to store downloaded files. This option does not apply to bareboard development.	Default: None.
Launch remote host application checkbox	Clear — Prevents the IDE from starting a host application on the remote computer. Checked — IDE starts a host application on the remote computer. (Also enables the corresponding text box, for the absolute path to the remote host application.) This option does not apply to bareboard development.	Default: Clear
Download OS checkbox	Clear — Prevents downloading a bootable image to the target system. Checked — Downloads the specified bootable image to the target system. (Also enables the Connection list box and OS Image Path text box.)	Default: Clear
Connection list box	Specifies the remote-connection type for downloading the bootable image to the target board.	Disabled if the Download OS checkbox is clear. Lists only the remote connections you add via the Remote Connections panel.
OS Image path	Specifies the host-side path of the bootable image to be downloaded to the target board.	Disabled if the Download OS checkbox is clear.

## Adding Remote Connections

**NOTE** Special-Edition software supports the following remote connections: P&E Microsystems USB, P&E Microsystems Cyclone Max, and Freescale USB TAP. Standard-Edition software supports only P&E Microsystems USB remote connection. For any other type of remote connection, you must have Professional-Edition software.

## Debugging

### Target Settings for Debugging

To add a remote connection, use the **Remote Connections** panel:

1. Select **Edit > Preferences**. The **IDE Preferences** window appears.
2. From the **IDE Preferences Panels** list, select **Remote Connections**. The **Remote Connections** panel moves to the front of the **IDE Preferences** window. [Figure 5.4](#) shows the **IDE Preferences** window at this point.

**Figure 5.4 IDE Preferences Window: Remote Connections Panel**

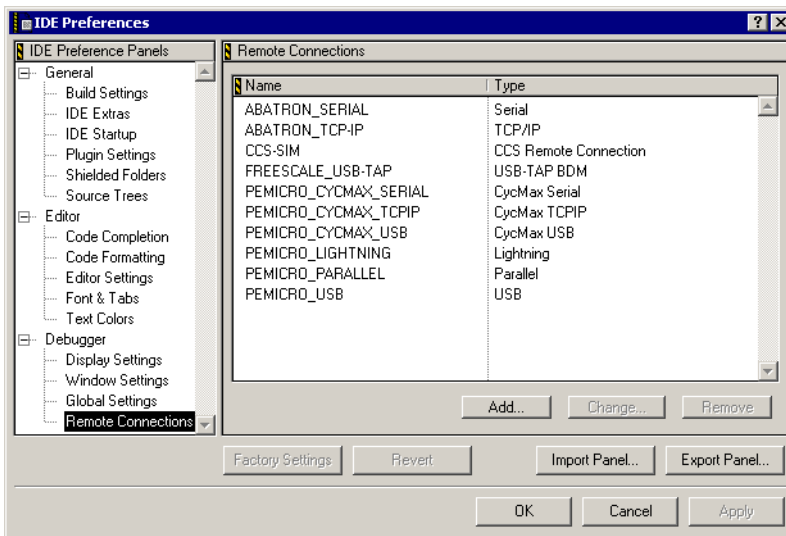

3. Click the **Add** button. The **New Connection** dialog box ([Figure 5.5](#)) appears.

**Figure 5.5 New Connection Dialog Box**

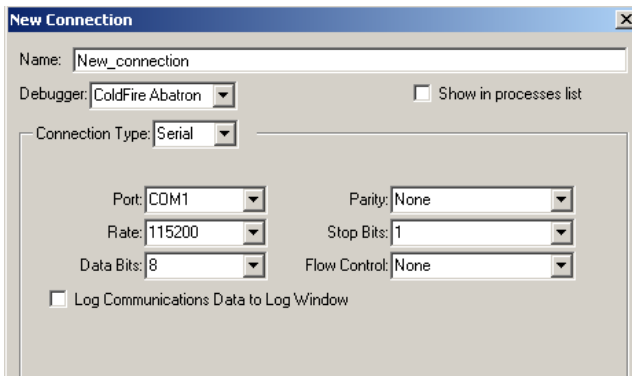

4. In the **Name** text box, enter a name for the new connection.

5. Use the **Debugger** list box to specify the debugger for the new remote connection: ColdFire Abatron, ColdFire P&E Micro, or ColdFire CCS (the simulator and USB TAP).
6. Check the **Show in processes list** checkbox to add this new connection to the official list. (To see this list of processes, select **View > Systems > List**.) Checking this checkbox also adds this new connection to the remote-connection list that pops up when you debug certain kinds of files.)
7. Use the Connection Type list box to specify the type — the remaining fields of the dialog box change appropriately.
8. Use the remaining fields of the New Connection dialog box to make any appropriate changes to the default values for connection type, port, rate, and so forth.
9. Click **OK**. The dialog box closes; the **Remote Connections** panel window displays the new connection.
10. This completes adding the new connection. You may close the **IDE Preferences** window.

## Changing Remote Connections

To change to an already-configured remote connection, use the **Remote Debugging** panel ([Figure 5.3](#)):

1. Click the arrow symbol of the **Connection** list box. The list of connections appears.
2. Select another connection. The list collapses; the list box displays your selection.
3. Click the **Edit Connections** button. A dialog box appears, showing the configuration of the remote connection.
4. Use the dialog box to make any appropriate configuration changes.
5. Click **OK**. The dialog box closes, confirming your configuration changes.

---

**NOTE** Any changes you make using the **Remote Debugging** panel apply to all targets that use the specified connection.

---

## CF Exceptions Panel

The **CF Exceptions** panel ([Figure 5.6](#)) is available with P&E Microsystems, simulator, and Freescale USB TAP remote connections. Use this panel to specify hardware exceptions that the debugger should catch. [Table 5.4](#) explains the elements of this panel.

Before you load and run the program, the debugger inserts its own exception vector for each exception you check in this panel. To use your own exception vectors instead, you should clear the corresponding checkboxes.

## Debugging

### Target Settings for Debugging

If you check any boxes, the debugger reads the Vector\_Based\_Register (VBR), finds the corresponding existing exception vector, then writes a new vector at that register location. The address of this new vector is offset 0x408 from the VBR address. For example, if the VBR address is 0x0000 0000, the new vector at address 0x0000 0408 covers the checked exceptions.

The debugger writes a Halt instruction and a Return from Exception instruction at this same location.

**NOTE** If your exceptions are in Flash or ROM, do not check any boxes of the **CF Exceptions** panel. Abatron remote connections ignore this panel, using instead the exception definitions in the Abatron firmware.

**Figure 5.6 CF Exceptions Panel**

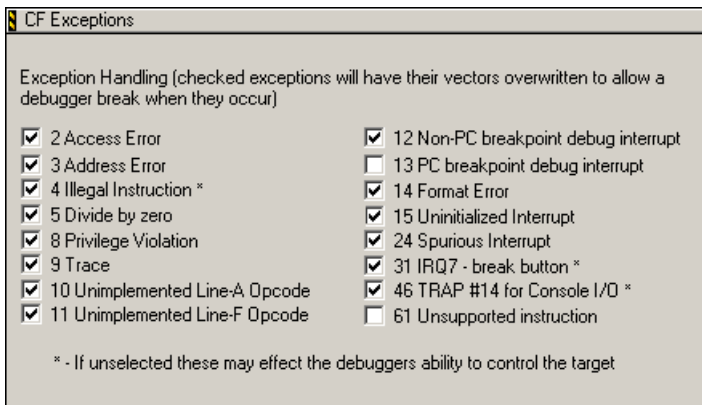

**Table 5.4 CF Exceptions Panel Elements**

Element	Purpose	Comments
2 Access Error checkbox	Clear — Ignores access errors. Checked — Catches and displays access errors.	Default: Checked
3 Address Error checkbox	Clear — Ignores address errors. Checked — Catches and displays address errors.	Default: Checked
4 Illegal Instruction checkbox	Clear — Ignores invalid instructions. Checked — Catches and displays invalid instructions.	Default: Checked



**Table 5.4 CF Exceptions Panel Elements (continued)**

<b>Element</b>	<b>Purpose</b>	<b>Comments</b>
5 Divide by zero checkbox	Clear — Ignores an attempt to divide by zero. Checked — Catches and displays any attempt to divide by zero.	Default: Checked
8 Privilege Violation checkbox	Clear — Ignores privilege violations. Checked — Catches and displays privilege violations.	Default: Checked
10 Unimplemented Line-A Opcode checkbox	Clear — Ignores unimplemented line-A opcodes. Checked — Catches and displays unimplemented line-A opcodes.	Default: Checked
11 Unimplemented Line-F Opcode checkbox	Clear — Ignores unimplemented line-F opcodes. Checked — Catches and displays unimplemented line-F opcodes.	Default: Checked
12 Non-PC breakpoint debug interrupt checkbox	Clear — Ignores non-PC breakpoint debug interrupts. Checked — Catches and displays non-PC breakpoint debug interrupts.	Default: Checked
13 PC breakpoint debug interrupt checkbox	Clear — Ignores PC breakpoint debug interrupts. Checked — Catches and displays PC breakpoint debug interrupts.	Default: Clear
14 Format Error checkbox	Clear — Ignores format errors. Checked — Catches and displays format errors.	Default: Checked
15 Uninitialized Interrupt checkbox	Clear — Ignores uninitialized interrupts. Checked — Catches and displays uninitialized interrupts.	Default: Checked
24 Spurious Interrupt checkbox	Clear — Ignores spurious interrupts. Checked — Catches and displays spurious interrupts.	Default: Checked
31 IRQ7 - break button checkbox	Clear — Ignores use of the IRQ7 break button. Checked — Catches and displays uses of the IRQ7 break button.	Default: Checked

## Debugging

### Target Settings for Debugging

**Table 5.4 CF Exceptions Panel Elements (continued)**

Element	Purpose	Comments
46 TRAP #14 for Console I/O checkbox	Clear — Ignores trap 14 for console I/O. Checked — Catches and displays uses of trap 14 for console I/O.	Default: Clear.
61 Unsupported instruction checkbox	Clear — Ignores unsupported instructions. Checked — Catches and displays unsupported instructions.	Default: Clear.

## Debugger Settings Panel

Use the **Debugger Settings** panel ([Figure 5.7](#)) to select and control the debug agent. [Table 5.5](#) explains the elements of this panel.

**Figure 5.7 Debugger Settings Panel**

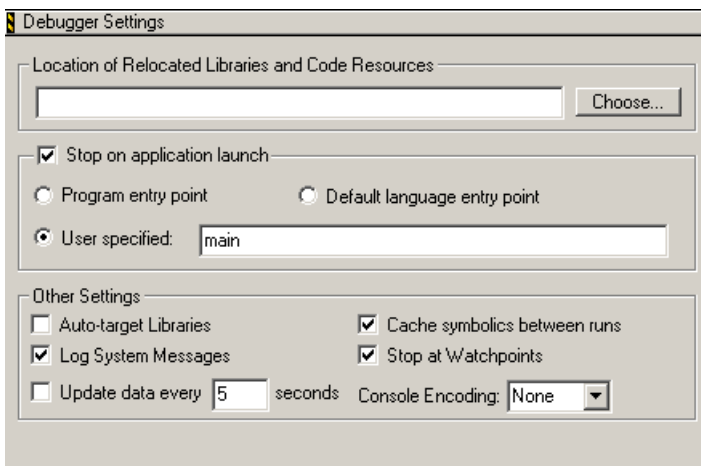

**Table 5.5 Debugger Settings Panel Elements**

Element	Purpose	Comments
Location of Relocated Libraries and Code Resources text box	Specifies the pathname of libraries or other resources related to the project. Type the pathname into this text box. Alternatively, click the Choose button, then use the subsequent dialog box to specify the pathname.	Default: None
Stop on application launch checkbox	Clear — Does not specify any debugging entry point; deactivates the subordinate options buttons and text box. Checked — Specifies the debugging entry point, via a subordinate option button: <b>Program entry point, Default language entry point, or User specified.</b>	Default: Checked, with Default language entry point option button selected. If you select the User specified option button, type the entry point in the corresponding text box.
Auto-target Libraries checkbox	Clear — Does <i>not</i> use auto-target libraries. Checked — Uses auto-target libraries.	Default: Clear
Log System Messages checkbox	Clear — Does <i>not</i> log system messages. Checked — Logs system messages.	Default: Checked
Update data every checkbox	Clear — Does not update data; deactivates the subordinate text box. Checked — Regularly updates data; enter the number of seconds in the subordinate text box.	Default: Clear
Cache symbolics between runs checkbox	Clear — Does <i>not</i> store symbolic values in cache memory between runs. Checked — After each run, stores symbolic values in cache memory.	Default: Checked

## Debugging

### Target Settings for Debugging

**Table 5.5 Debugger Settings Panel Elements (continued)**

Element	Purpose	Comments
Stop at Watchpoints checkbox	Clear — Does <i>not</i> stop at watchpoints. Checked — Stops at watchpoints.	Default: Checked
Console Encoding list box	Specifies the type of console encoding.	Default: None

## CF Interrupt Panel

Debugging an application involves single-stepping through code. But if you do not modify interrupts that are part of normal code execution, the debugger could jump to interrupt-handler code, instead of stepping to the next instruction.

So before you start debugging, you must mask some interrupt levels, according to your processor. To do so, use the **CF Interrupt** panel ([Figure 5.8](#)); [Table 5.6](#) explains the elements of this panel.

**Figure 5.8 CF Interrupt Panel**

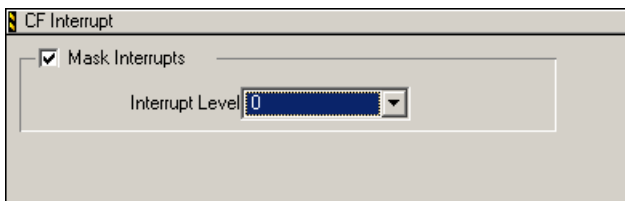

**Table 5.6 CF Interrupt Panel Elements**

Element	Purpose	Comments
Mask Interrupts checkbox	Clear — Ignores interrupts. Checked — Masks interrupts of the specified and lower levels, but allows higher-level interrupts.	Default: Clear.
Interrupt Level list box	Specifies the interrupt level, from 0 (low) to 7 (high).	Default: 0.

---

**NOTE** The exact definitions of interrupt levels are different for each target processor, and masking all interrupts can cause inappropriate processor behavior. This means that finding the best interrupt level to mask can involve trial and error.

Be alert for any code statements that change the interrupt mask: stepping over such a statement can modify your settings in this panel.

---

## Remote Connections for Debugging

To debug an application on the remote target system, you must use a remote connection.

A *remote connection* is the physical connection from the host to the target board, together with the settings that describe how the CodeWarrior IDE should connect to and control program execution on target boards or systems. The remote connection includes the debugger protocol, connection type, and connection parameters the IDE should use when it connects to the target system. This section shows you how to access remote connections in the CodeWarrior IDE, and describes the various debugger protocols and connection types the IDE supports.

---

**NOTE** We have included several types of remote connections in the default CodeWarrior installation. You can modify these default remote connections to suit your particular needs.

---

---

**TIP** When you import a Makefile into the CodeWarrior IDE to create a CodeWarrior project, the IDE asks you to specify the type of debugger interface (remote connection) you want to use. To debug the generated CodeWarrior project, you must properly configure the remote connection you selected when you created the project.

---

*For Special- and Standard-Edition software*, the ColdFire debugger uses a plug-in architecture to support the P&E Microsystems Parallel and USB remote-connection protocols.

*For Professional-Edition software*, the ColdFire debugger uses a plug-in architecture to support any of these remote-connection protocols:

- Abatron Serial
- Abatron TCP-IP
- Freescale USB-TAP
- P&E Microsystems Parallel
- P&E Microsystems USB

## Debugging

### Remote Connections for Debugging

---

- P&E Microsystems Lightning
- P&E Microsystems Cyclone MAX Serial
- P&E Microsystems Cyclone MAX TCP-IP
- P&E Microsystems Cyclone MAX USB
- Simulator (CCS-SIM)

---

**NOTE** In addition to the protocols mentioned above, Code Warrior for ColdFire now also allows use of additional run control devices through the GDI protocol. For hardware interfaces which use the GDI protocol, please refer to the user's manual of that particular interface for installation procedures. As interfaces which use the GDI protocol make use of proprietary DLL files, Freescale does not offer support for capabilities of a particular interface or guarantee functionality. Please contact your interface supplier for any support questions.

---

Before you debug a project, you must configure or modify the settings of your remote-connection protocol. Follow these steps:

1. From the main menu bar, select **Edit > Target Settings**. The **Target Settings** window appears.
2. Select **Target Settings Panels > Debugger > Remote Debugging**. The **Remote Debugging** panel moves to the front of the window.
3. Use the **Connection** list box to specify a remote connection. The supported list of remote connections is shown in [Figure 5.9](#).

**Figure 5.9 Connection List selection panel**

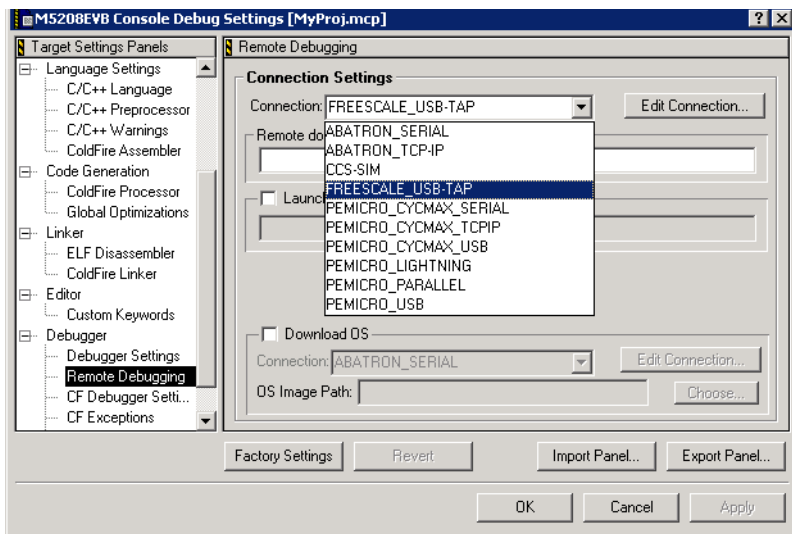

4. Click the **Edit Connection** button. A corresponding remote connection dialog box appears.
5. Use the dialog box to input communication settings, according to text below.

## Abatron Remote Connections

[Figure 5.10](#) shows the configuration dialog box for an Abatron *serial* remote connection. [Figure 5.11](#) show the configuration dialog box for an Abatron *TCP/IP* remote connection. [Table 5.6](#) explains the elements of these dialog boxes.

**Figure 5.10 Serial Abatron Remote-Connection Dialog Box**

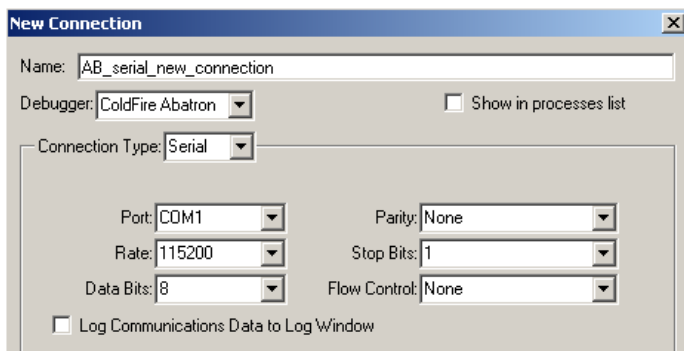

## Debugging

### Remote Connections for Debugging

**Figure 5.11 TCP/IP Abatron Remote-Connection Dialog Box**

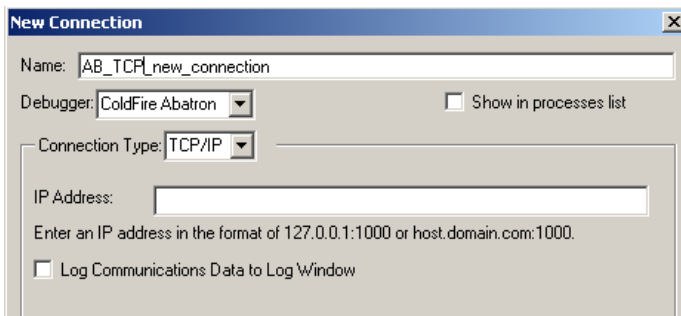

**Table 5.7 Abatron Dialog-Box Elements**

Element	Purpose	Comments
Name text box	Identifies the remote connection.	For an existing connection, already has a value.
Debugger list box	Identifies the debugger.	For an existing connection, already specifies ColdFire Abatron
Show in processes list checkbox	Clear — Leaves the connection off the official list. Checked — Adds connection to the official list (select View > Systems > List); also adds connection to the pop-up list for debugging certain kinds of file.	Default: Clear
Connection Type list box	Specifies serial or TCP/IP.	Changing this value changes the subordinate elements of the dialog box, as <a href="#">Figure 5.10</a> and <a href="#">Figure 5.11</a> show.
Port list box	Specifies the serial port: COM1, COM2, COM3, ... or COM256.	Default: COM1.
Rate list box	Specifies transfer speed: 300, 1200, 2400, 9600, 9,200, 38,400, 57,600, 115,200, or 230,400 baud.	Default: 38,400 baud
Data Bits list box	Specifies number of data bits per character: 4, 5, 6, 7, or 8.	Default: 8



**Table 5.7 Abatron Dialog-Box Elements (continued)**

Parity list box	Specifies parity type: None, Odd, or Even.	Default: None
Stop Bits list box	Specifies number of stop bits: 1, 1.5, or 2	Default: 1
Flow Control list box	Specifies flow-control type: None, Hardware (RTS/CTS), or Software (XONN, XOFF).	Default: None
Log Communications Data to Log Window	Clear — Does not copy communications in log window. Checked — Copies communications in log window.	Default: Clear
IP Address text box	Specifies IP address.	Must be in format 127.0.0.1:1000 or in format host.domain.com:1000.

---

**NOTE** For an Abatron remote connection, be sure to *clear* the checkboxes **Use Target Initialization File** and **Use Memory Configuration File**, of the **CF Debugger Settings** panel.

---

## Freescal Remote Connections

[Figure 5.12](#) shows the dialog box that appears for Freescal’s USB TAP remote connection when the Connection Type list box is set to USB-TAP BDM. [Figure 5.13](#) shows the dialog box that appears when the Connection Type list box is set to CCS Remote Connection. [Table 5.8](#) explains the elements of these dialog boxes.

## Debugging

### Remote Connections for Debugging

**Figure 5.12 USB-TAP BDM**

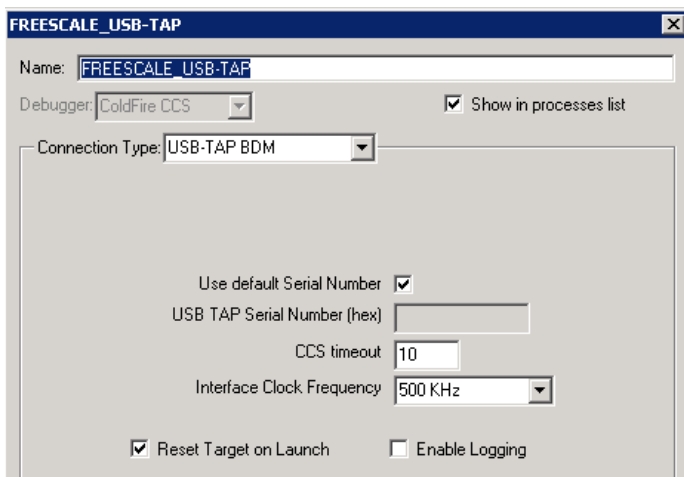

**Figure 5.13 CCS Remote Connection**

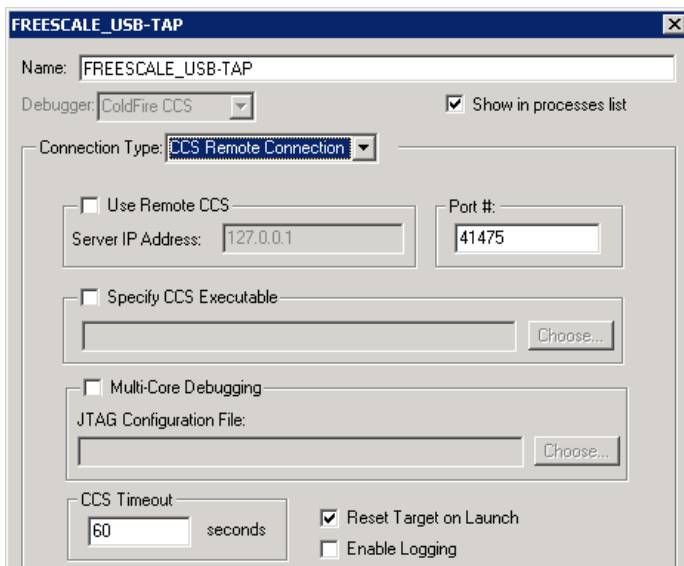

**Table 5.8 USB TAP Dialog Box Elements**

<b>Element</b>	<b>Purpose</b>	<b>Comments</b>
Name text box	Identifies the remote connection.	For an existing connection, already has a value.
Debugger list box	Identifies the debugger.	For an existing connection, already specifies ColdFire CCS
Show in processes list checkbox	Clear — Leaves the connection off the official list. Checked — Adds connection to the official list (select View > Systems > List); also adds connection to the pop-up list for debugging certain kinds of file.	Default: Clear
Connection Type list box	Specifies USB-TAP BDM or CCS remote connection. Changing this value changes the other elements of this dialog box, as in <a href="#">Figure 5.12</a> and <a href="#">Figure 5.13</a> .	Default: USB-TAP BDM
Use Default Serial Number (in USB-TAP BDM dialog box)	Each USB TAP device has a serial number (SN) burned into flash memory. The SN enables using multiple USB TAP devices during a single debugging session. Normally is checked.	Default: Checked.
USB TAP Serial Number (hex) (in USB-TAP BDM dialog box)	If the “Use Default Serial Number” checkbox is checked, enter the serial number here. Should be same SN burned into flash on the device.	Default: Grayed out and blank.
CCS Timeout	Timeout (in seconds) that CCS waits for a reply from the target before retrying.	Default: 10
Interface Clock Frequency (in USB-TAP BDM dialog box)	Clock speed of the BDM or JTAG interface.	Default: 5.12MHz
Use Remote CCS (in CCS Remote Connection dialog box)	If checked, CCS uses Server IP Address to communicate with remote USB TAP (via TCP-IP).	Default: Not checked

## Debugging

### Remote Connections for Debugging

**Table 5.8 USB TAP Dialog Box Elements (continued)**

Server IP Address (in CCS Remote Connection dialog box)	IP address of the CCS server or debug interface device, to be used if Use Remote CCS checkbox is checked.	Default: Grayed out, with value: 127.0.0.1
Specify CCS Executable (in CCS Remote Connection dialog box)	If checked, then enter the path and file name of the CCS executable you'd like to use.	Default: Not checked
Multi-Core Debugging (in CCS Remote Connection dialog box)	If checked, then enables multi-core debugging support.	Default: Not checked. In ColdFire debugging, not used.
JTAG Configuration File (in CCS Remote Connection dialog box)	If Multi-Core Debugging is checked, then this field can be used to specify a desired JTAG configuration file.	Default: Grayed out. In ColdFire debugging, not used.
Reset Target on Launch	Determines whether target board (and processor) is reset when debugging is initiated.	Default: Checked
Enable Logging	If checked, logs CCS communications to log window or file.	Default: Not checked

## P&E Microsystems Remote Connections

[Figure 5.14](#), [Figure 5.15](#), [Figure 5.16](#), [Figure 5.17](#), [Figure 5.18](#), and [Figure 5.19](#) show the configuration dialog boxes for PE Micro remote connections. [Table 5.9](#) explains the elements of these dialog boxes.

**Figure 5.14 P&E Micro Remote Connection (Parallel)**

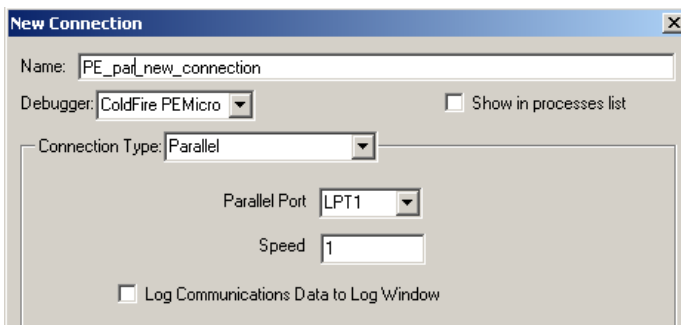

**Figure 5.15 P&E Micro Remote Connection (USB)**

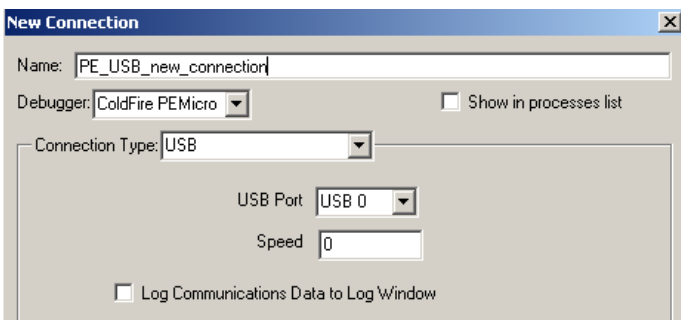

**Figure 5.16 P&E Micro Remote Connection (Lightning)**

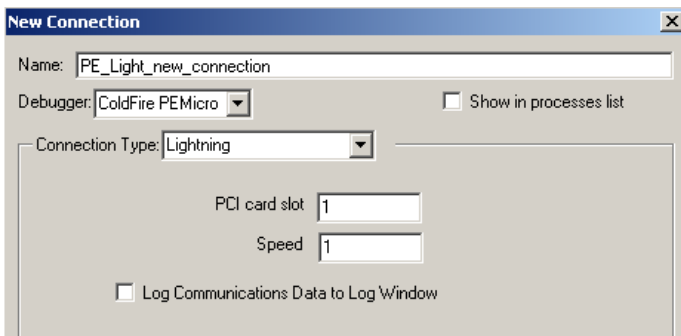

## Debugging

### Remote Connections for Debugging

**Figure 5.17 P&E Micro Remote Connection (Cyclone Max Serial)**

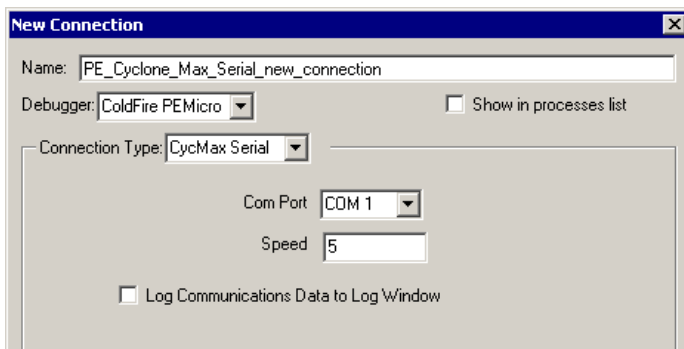

**Figure 5.18 P&E Micro Remote Connection (Cyclone Max USB)**

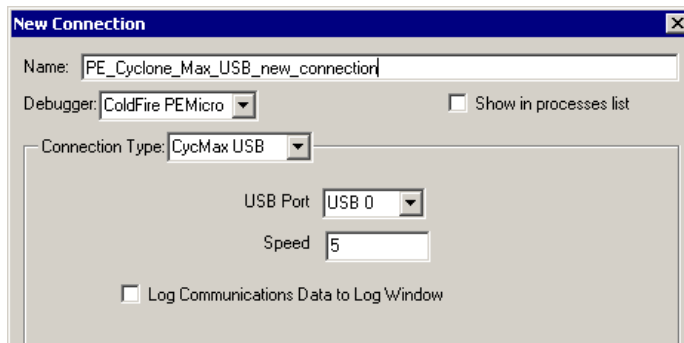

**Figure 5.19 P&E Micro Remote Connection (Cyclone Max TCPIP)**

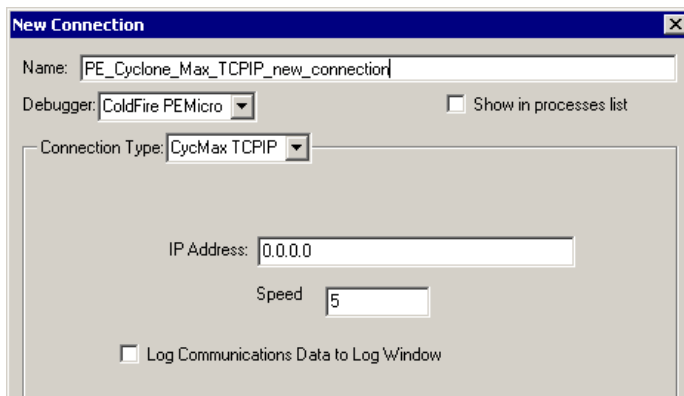

**Table 5.9 P&E Micro Dialog Box Elements**

<b>Element</b>	<b>Purpose</b>	<b>Comments</b>
Name text box	Identifies the remote connection.	For an existing connection, already has a value.
Debugger list box	Identifies the debugger.	For an existing connection, already specifies ColdFire P&E Micro
Show in processes list checkbox	Clear — Leaves the connection off the official list. Checked — Adds connection to the official list (select View > Systems > List); also adds connection to the pop-up list for debugging certain kinds of file.	Default: Clear
Connection Type list box	Specifies Parallel, USB, Lightning, Cyclone Max Serial, Cyclone Max USB, or Cyclone Max TCPIP.	Changing this value changes the subordinate elements of the dialog box, as <a href="#">Figure 5.14</a> , <a href="#">Figure 5.15</a> , <a href="#">Figure 5.16</a> , <a href="#">Figure 5.17</a> , <a href="#">Figure 5.18</a> , and <a href="#">Figure 5.19</a> show.
Log Communications Data to Log Window	Clear — Does not copy communications in log window. Checked — Copies communications in log window.	Default: Clear
Parallel Port list box	Specifies the parallel port: LPT1, LPT2, LPT3, or LPT4.	Default: LPT1.
Speed text box (in parallel dialog box)	Integer that modifies the data stream transfer rate: 0 specifies the fastest rate. The greater the integer, the slower the rate.	For a parallel remote connection there is no firm mathematical relationship, so you may need to experiment to find the best transfer rate. In case of problems, try value 25.
USB Port list box (in USB dialog box and Cyclone Max USB dialog box)	Specifies the USB port: USB 0, USB 1, USB 2, or USB 4.	Default: USB 0

## Debugging

### Remote Connections for Debugging

**Table 5.9 P&E Micro Dialog Box Elements (continued)**

Speed text box (in USB dialog box)	Integer N that specifies the data stream transfer rate per the expression $(1000000/(N+1))$ hertz.	0 specifies 1000000 hertz, or 1 megahertz. 1 (the default) specifies 0.5 megahertz. 31 specifies the slowest transfer rate: 0.031 megahertz.
PCI card slot list box	Specifies PCI slot that the board uses.	Default: 1
Speed text box (in Lightning dialog box)	Integer N that specifies the data stream transfer rate per the expression $(33000000/(2*N+5))$ hertz.	0 specifies 6600000 hertz, or 6.6 megahertz. 1 (the default) specifies 4.7 megahertz. 31 specifies the slowest transfer rate: 0.49 megahertz.
COM Port list box (in Cyclone Max Serial dialog box)	Specifies the serial port: COM1, COM2, COM3, ... or COM256.	Default: COM1.
IP Address text box (in Cyclone Max TCP/IP dialog box)	Specifies IP address.	Must be in format 127.0.0.1:1000 or in format host.domain.com:1000.
Speed text box (in Cyclone Max dialog boxes)	Integer N that specifies the data stream transfer rate per the expression $(50000000/(2*N+5))$ hertz.	0 specifies 5000000 hertz, or 5.0 megahertz. 5 (the default) specifies 3.33 megahertz. 31 specifies the slowest transfer rate: 0.75 megahertz.

**NOTE** For a P&E Micro remote connection, be sure to *check* the checkboxes **Use Target Initialization File** and **Use Memory Configuration File**, of the **CF Debugger Settings** panel.

## ISS Remote Connection

**NOTE** Special-Edition software does not support the ISS. To use the ISS, you must have Standard- or Professional-Edition software.

[Figure 5.20](#) shows the configuration dialog box for ColdFire Instruction Set Simulator (ISS) remote connections. [Table 5.10](#) explains the elements of this dialog box.



**Figure 5.20** ISS Remote Connection

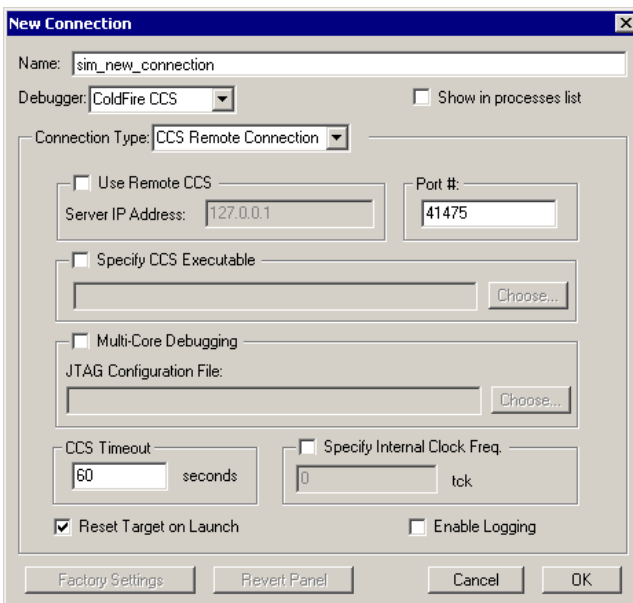

**NOTE** To use the ISS for V2 and V4e cores, create a CCS remote connection. Alternatively, use the default **CCS - SIM** connection from the **Remote Connection** panel list.

**Table 5.10** ISS Dialog-Box Elements

Elements	Purpose	Comments
Name text box	Identifies the remote connection.	For an existing connection, already has a value.
Debugger list box	Identifies the debugger.	For an existing connection, already specifies ColdFire CCS
Show in processes list checkbox	Clear — Leaves the connection off the official list. Checked — Adds connection to the official list (select View > Systems > List); also adds connection to the pop-up list for debugging certain kinds of file.	Default: Clear

## Debugging

### Remote Connections for Debugging

**Table 5.10 ISS Dialog-Box Elements (*continued*)**

Elements	Purpose	Comments
Connection Type list box	Specifies CCS Remote Connection	Changing this value changes other elements of the dialog box.
Use Remote CCS checkbox	Clear — Launches the CCS locally. Checked — Starts debug code on a remote target; activates Server IP Address text box.	ISS must be running and connected to a remote target device.
Server IP Address text box	Specifies IP address of the remote machine, in format 127.0.0.1:1000 or host.domain.com:1000.	Available only if you check the Use Remote CCS checkbox.
Port # text box	Specifies the port number the CCS uses	Use only 40969 — the number of the port pre-wired for the simulator.
Specify CCS Executable checkbox	Clear — Uses the default CCS executable file. Checked — Lets you specify a different CCS executable file, activating the text box and Choose button. To do so, click the Choose button, then use the subordinate dialog box to select the executable file. Clicking OK puts the pathname in the text box.	Does not pertain to the simulator.
Multi-Core Debugging checkbox	Clear — Does <i>not</i> debug code on a multicore target. Checked — Lets you specify the JTAG chain for debugging on a multicore target, activating the text box and Choose button. To do so, click the Choose button, then use the subordinate dialog box to select the executable file. Clicking OK puts the pathname in the text box.	Does not apply to the simulator.
CCS Timeout text box	Specifies the number of seconds the CCS should wait for a connection to go through, before trying the connection again.	

## BDM Debugging

This section show two examples of connections for Background Debugging Mode (BDM) debugging of a ColdFire target board.

### Connecting a P&E Parallel Connector

[Figure 5.21](#) depicts connections for a P&E Parallel Remote Connection.

**Figure 5.21 P&E Parallel Remote Connector Setup**

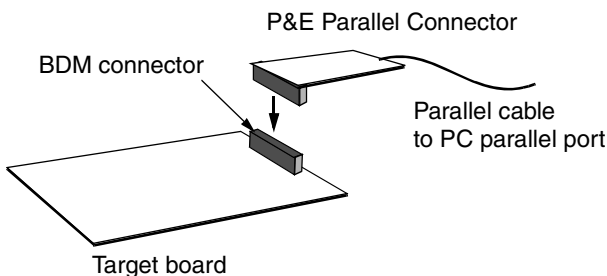

Follow these steps:

1. Plug the P&E Parallel Connector onto the target-board BDM connector.
2. Connect the parallel cable to the P&E Parallel Connector.
3. Connect the other end of the parallel cable to a parallel port of your PC.
4. This completes P&E Parallel connection. The P&E Parallel Remote Connection automatically installs a default set of drivers and interface dlls on your PC.

**NOTE** You must have the correct P&E Parallel Connector for your target. If necessary, contact P&E Microsystems for assistance. The Windows drivers for P&E Microsystems BDM cables are available as well in subdirectory `bin\Plugins\Support\ColdFire\pemicro` of your CodeWarrior installation directory.

### Connecting an Abatron BDI Device

[Figure 5.22](#) depicts connections for an Abatron BDI device.

**Figure 5.22 Abatron BDI Connections**

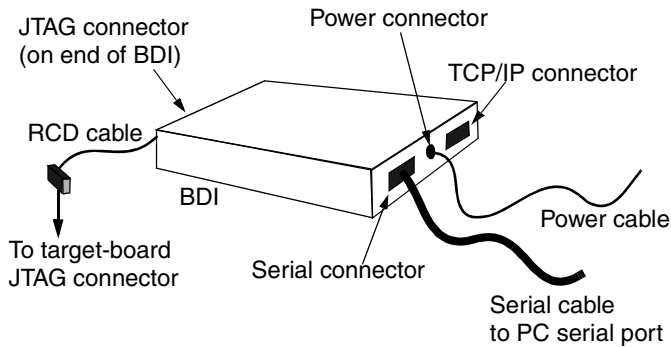

Follow these steps:

1. Connect the BDI device to your computer.
  - a. Serial connection: Connect a serial cable between the BDI serial connector and a serial port of the PC, as [Figure 5.22](#) shows.
  - b. TCP/IP connection: Connect a TCP/IP cable between the BDI TCP/IP connector and an appropriate port of your PC.
2. Connect the appropriate RCD cable between the BDI JTAG connector and the JTAG connector of your target board. (The board JTAG connector is a 26-pin Berg-type connector.)

**NOTE** Certain target boards, such as the MCF5485, MCF5475, MCF5235, and MCF5271, require a different RCD cable than do other ColdFire boards. To make sure that your cable is correct, see the Abatron reference manual or visit <http://www.abatron.ch>.

3. Connect the power cable between the BDI power connector and a 5-volt, 1-ampere power supply, per the guidance of the Abatron user manual.
4. This completes cable connections.

**NOTE** Before using an Abatron remote connection, you must

1. Make sure that you have the correct drivers and configuration utility for your target board.
2. Use Abatron software to configure the BDI device, per the guidance of the Abatron user manual.

---

Before you use the BDI for ROM/Flash debugging, you must check the **Use Breakpoint Logic** checkbox of the **BDI Working Mode** dialog box.

---

## Debugging ELF Files without Projects

The CodeWarrior debugger can debug an ELF file that you created in a different environment. But before you begin, you must update IDE preferences and customize the default XML project file. (The CodeWarrior IDE uses the XML file to create a project with the same target settings for any ELF file that you open to debug.)

### Updating IDE Preferences

Follow these steps:

1. From the main menu bar, select **Edit > Preferences**. The **IDE Preferences** window appears.
2. From the **IDE Preferences Panels** pane, select **Build Settings**. The **Build Settings** panel ([Figure 5.23](#)) moves to the front of the window.

**Figure 5.23 Build Settings Panel**

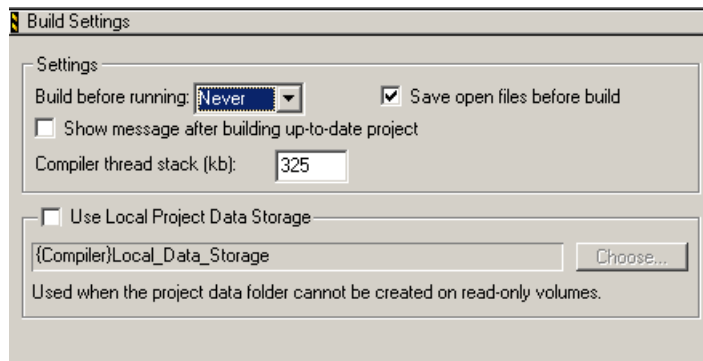

3. Make sure that the **Build before running** list box specifies **Never**.

---

**NOTE** Selecting **Never** prevents the IDE from building the newly created project, which is useful if you prefer to use a different compiler.

---

4. Select **Edit > Preferences > Global Settings**. The **Global Settings** panel ([Figure 5.24](#)) moves to the front of the window.

## Debugging

### Debugging ELF Files without Projects

Figure 5.24 Global Settings Panel

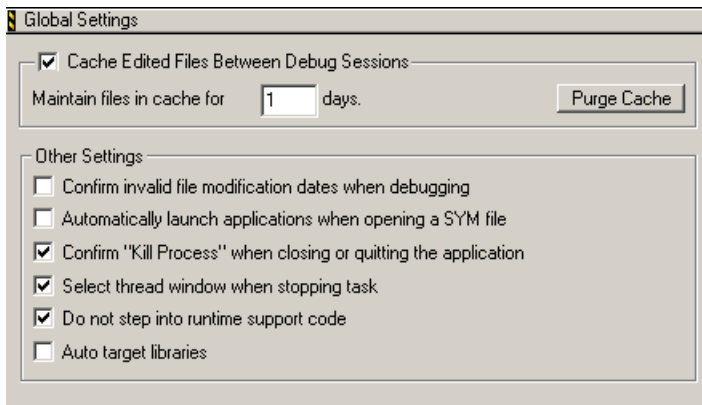

5. Make sure that the **Cache Edited Files Between Debug Sessions** checkbox is clear.
6. Close the **IDE Preferences** window.
7. This completes updating IDE preference settings; you are ready to customize the default XML project file.

## Customizing the Default XML Project File

CodeWarrior software creates a new CodeWarrior project for any ELF file that you open to debug. To create the new project, the software uses the target settings of the default XML project file:

```
bin\plugins\support\CF_Default_Project.xml
```

For different target settings, you must customize this default XML file. Follow these steps:

1. Import the default XML project file.
  - a. Select **File > Import Project** — a file-select dialog box appears.
  - b. Navigate to subdirectory `bin\plugins\support`.
  - c. Select file `CF_Default_Project.xml`.
  - d. Click **OK** — a new project window appears for file `CF_Default_Project.xml`.
2. Change target settings of the new project.
  - a. Select **Edit > Target Settings** — the **Target Settings** window appears.
  - b. From the **Target Settings Panels** pane, select any panel — that panel moves to the front of the window.
  - c. Review/update panel settings.

- d. Repeat substeps b and c for all other appropriate panels.
  - e. When all settings are correct, click **OK** — the **Target Settings** window closes; the system updates project settings.
3. Close the project window.
  4. Export the modified target settings.
    - a. Select **File > Export Project** — a file-select dialog box appears.
    - b. Navigate to subdirectory `bin\plugins\support`.
    - c. Select the file you just modified: `CF_Default_Project.xml`.
    - d. Click **OK** — the system saves your modified file `CF_Default_Project.xml` over the old file.
  5. This completes XML-file customization — the new `CF_Default_Project.xml` file includes your target-settings changes; you are ready to debug an ELF file.

## Debugging an ELF File

Once you have updated IDE preferences and customized the default XML file, you are ready to debug an ELF file (that includes symbolics information). Follow these steps:

1. Confirm that a remote connection exists for the ColdFire target.
2. Open Windows Explorer.
3. Navigate to the ELF file.
4. Drag the ELF file to the IDE main window — the IDE uses the default XML file to create a new project, opening a new project window.

---

**NOTE** As ELF-file DWARF information does not include full pathnames for assembly (`.s`) files; the IDE cannot find these files when it creates the project. But when you debug the project, the IDE does find the assembly files that reside in a directory that is a project access path. If any assembly files still lack full pathnames, you can add their directory to the project manually, so that the IDE finds the directory whenever you open the project.

---

5. Select **Project > Debug** — the IDE starts the debugger; the debugger window appears.
6. Begin debugging.

## Additional ELF-Debugging Considerations

Any of these points may make your debugging more efficient:

## Debugging

### Special Debugger Features

---

- Once the IDE creates a .mcp project for your ELF file, you can open that project instead of dropping your ELF file onto the IDE.
- To delete an old access path that no longer applies to the ELF file, use either of two methods:
  - Use the **Access Path** target settings panel to remove the access path from the project manually.
  - Delete the existing project for the ELF file, then drag the ELF file to the IDE to recreate a project.
- To have the project include only the current files, you must manually delete project files that no longer apply to the ELF.
- To recreate a project from an ELF file:
  - If the project is open, close it.
  - Delete the project (.mcp) file.
  - Drag the ELF file to the IDE — the IDE opens a new project, based on the ELF file.

## Special Debugger Features

This section explains debugger features that are unique to ColdFire-platform targets.

### ColdFire Menu

To see the unique Coldfire debugger menu, select **Debug > ColdFire**. [Table 5.11](#) lists its selections.

**Table 5.11 ColdFire Debug Menu**

Selection	Explanation
Reset Target	Sends a reset signal to the target processor. (Not available unless the target processor supports this signal.)
Save Memory	Saves target-board data to disk, as a binary image file.
Load Memory	Writes previously saved, binary-file data to target-board memory.
Fill Memory	Fills a specified area of memory with a specified value.
Save Registers	Saves contents of specified register to a text file.



**Table 5.11 ColdFire Debug Menu (continued)**

Selection	Explanation
Restore Registers	Writes previously saved register contents back to the registers.
Watchpoint Type	<p>Specifies the type:</p> <p>Read — A read from the specified memory address stops execution.</p> <p>Write — A write to the specified memory address stops execution.</p> <p>Read/Write — Either a read from or write to the specified memory address stops execution.</p> <p>(Not available unless the target processor and debug connection support watchpoints.)</p>

## Working with Target Hardware

To have the IDE work with target hardware, use Debug-menu selections Connect and Attach.

### Connect

This selection tells the IDE to read the contents of target-board registers and memory; these contents help you determine the state of the processor and target board. You can use this selection in combination with the **Load/Save Memory** and **Fill Memory** selections of the ColdFire menu to create a memory dump, load memory contents, or initialize memory with specific patterns of data.

You can have the IDE connect to a target board that uses **ColdFire Abatron** or **ColdFire P&E Micro** protocols.

The Connect selection works with a remote connection that you define in a project:

1. Bring forward the project you want to use. (The project must have at least one remote connection defined for the target hardware.)
2. Select **Debug > Connect** — a **Thread** window appears, showing where the IDE stops program execution. The debugger configuration file is executed.
3. Use the **Thread** window, with other IDE windows, to see register views and memory contents.

## Using the Simple Profiler

---

**NOTE** For a detailed explanation of how to instrument your code for profiling and how to interpret the results, see the “Profiler” chapter in the *IDE 5.7 User’s Guide*.

---

The following steps for enabling and using the profiling tool make reference to ColdFire-specific features that may not be mentioned in the *IDE User’s Guide*:

1. Specify profiling, in *one* of these ways:
  - a. In the ColdFire Processor panel, check the Generate code for profiling checkbox.
  - b. Use the `#pragma profile on` directive before the function definition and use the `#pragma profile off` directive after the function definition.
  - c. Use the `-profile` option or the `#pragma` directives with the command-line compiler.
2. If you use the `#pragma` directives, add the profiler libraries to your project. (These libraries are in subdirectory `\E68K_Support\Profiler\Lib\` of your CodeWarrior installation directory.)
3. In your source code, use the `#include` directive to include header file `Profiler.h`. (This file is in subdirectory `\E68K_Support\Profiler\include\` of your CodeWarrior installation directory.)
4. If necessary, instrument your code with the following function calls. These functions are documented in the “Profiler” chapter of the IDE User’s Guide:
  - a. `ProfilerInit` — initializes the profiler.
  - b. `ProfilerClear` — removes existing profiling data.
  - c. `ProfilerSetStatus` — turns profiling on (1) or off (0).
  - d. `ProfilerDump("filename")` — dumps the profile data to a profiler window or to the specified file.
  - e. `ProfilerTerm` — exits the profiler.

The profiler libraries use the external function `getTime` to measure the actual execution time.

---

**NOTE** For a list of ColdFire platforms supported by the profiler, see the subdirectory `\E68K_support\Profiler\Support\` of your CodeWarrior installation directory. The files in that directory also contain examples using the `getTime()` function.

---

# Instruction Set Simulator

---

This chapter explains how to use the Instruction Set Simulator (ISS). Using the ISS with the CodeWarrior™ debugger, you can debug code for a ColdFire target.

Additionally, if you run the ISS on your host computer, you can share target-board access with remote users of the CodeWarrior debugger.

In the same way, you can access the target board of any remote computer that is running the ISS, provided that you know the IP address and ISS port number of that remote computer.

---

**NOTE** Special-Edition software does not support the ISS; to use the ISS, you must have Standard- or Professional-Edition software.

Do not move the ISS folders or files from its location in subdirectory `\Bin\Plugins\Support\Sim`, of your CodeWarrior installation directory. You can start the ISS only from the CodeWarrior debugger.

---

This chapter consists of these sections:

- [Features](#)
- [Using the Simulator](#)
- [ISS Configuration Commands](#)
- [Sample Configuration File](#)
- [ISS Limitations](#)

## Features

Your CodeWarrior software supports the Instruction Set Simulator (ISS) for V2 and V4e cores.

### ColdFire V2

For V2 cores the ISS features are:

- *Instruction set* — modeling only of the original ColdFire v2 instruction set, *without* ISA+ support of the 5282 processor.

## Instruction Set Simulator

### Features

---

- *MAC* — modeling of the MAC *without* the EMAC of the 5282 processor. (This affects register accesses.)
- *Cache* — modeling of the original ColdFire v2 direct-mapped instruction cache, *without* modeling of the 5282 instruction and data cache.
- *Format exceptions* — not implemented.
- *IPSBAR Functionality (5282 Peripherals)* — modeling of the IPSBAR register and Synchronous DRAM Controller (SDRAMC) module. (No modeling of other 5282 peripherals or related behavior.)
- *IPSBAR register fields* — all implemented.
- *SDRAMC registers* — five present:
  - DCR
  - DACR0
  - DACR1
  - DMR0
  - DMR1
- *DCR* — this model includes reads from and writes to this register, but ignores all internal fields of this register.
- *DACRx* — this model includes reads from and writes to these fields. (The SDRAMC model covers functionality only of DACRx register fields BA and CBM, ignoring other fields.)
- *DMRx* — this model includes reads from and writes to these fields. (The SDRAMC model covers functionality only of DMRx register fields BAM and V, ignoring other fields.)
- *KRAM, KROM* — support as much as 512 kilobytes of memory.
- *Memory wait states* — supported.
- *A-line exceptions* — not generated, as this model includes MAC.

---

**NOTE** The V2 ISS has pipeline delays that can lead to debugger defects.

---

## ColdFire V4e

For V4e cores the ISS features are:

- *Instruction set* — modeling for all instructions.
- *EMAC* — modeling of the EMAC.
- *FPU* — not supported.

- **Cache** — modeling of the ColdFire V4e four-way set-associative instruction and data caches. (Caches always are physically tagged and physically addressed.)
- **MMU model** — partially supported.
- **WDEBUG instruction** — not supported, as the model does not support the WDEBUG module.
- **WDDATA instruction** — not supported, as the model does not support the WDDATA module.
- **PULSE instruction** — not supported, as the model does not support the PULSE debug module.
- **IPSBAR Functionality (5282 Peripherals)** — modeling of the IPSBAR register. (No modeling of other peripherals or related behavior.)
- **A-line exceptions** — not generated, as this model includes EMAC.
- **F-line exceptions** — not generated, as this model includes an FPU.
- **Clock multiplier** — not supported.
- **Memory wait states** — not supported.

---

**NOTE** Pipeline delay can lead to appearance problems in the debugger variable viewer.

---

## Using the Simulator

When you use a local ISS connection for debugging, the IDE starts the ISS automatically; the ISS icon  appears on the taskbar.

Right-click the icon to access the ISS pop-up menu. Its selection are:

- **Configure** — opens the ISS configuration options dialog box
- **Show console** — displays the ISS console window. (Another way to open this console window is double-clicking the ISS icon.)
- **Hide console** — hides the ISS console window
- **About CCSSIM2** — displays version information
- **Quit CCS** — stops the ISS.

## Console Window

Use the ISS console window to view and change server connection options. You may type commands at the command line, or select them from the menu bar.

**NOTE** Do not use the console window to modify settings during a debug session. This would affect the debug state.

---

## Viewing ISS Registers

To view the ISS registers, select **View > Registers** — the **Registers** window ([Figure 6.1](#)) appears.

**Figure 6.1 Register Window: ISS Register Values**

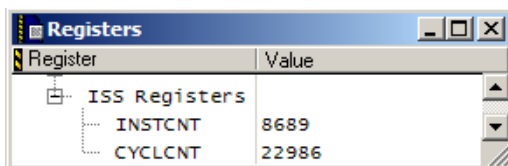

Register	Value
ISS Registers	
INSTCNT	8689
CYCLCNT	22986

You may edit the ISS register values that this window shows.

- INSTCNT (Instruction Count) is the number of instructions executed in a debug session.
- CYCLCNT (Cycle Count) is the number of elapsed clock cycles in a debug session.

**NOTE** These registers are unique to ISS projects; other projects do not have these registers.

---

## ISS Configuration Commands

The ISS reads configuration information from configuration files `ColdFire2.cfg` (V2 core) and `ColdFire4.cfg` (V4e core). Both files are in subdirectory `\Bin\Plugins\Support\Sim\ccsim2\bin` of your CodeWarrior installation directory.

**NOTE** Do not change the location of the configuration files, or the ISS may not work properly.

If you cannot use the ISS to start a debug session, you probably must reduce the memory that file `ColdFire2.cfg` or `ColdFire4.cfg` defines. And for an MCF5282 or other processor core that had IPSBAR, you must use the `ipsbar` command to configure the settings.

---

The configuration files consist of text commands, each on a single line:

- Some argument values are numerical.
- Possible boolean argument values are `true` (or `yes`) and `false` (or `no`).
- Comment lines must start with the `#` character.

The rest of this section consists of explanations for the ISS configuration commands:

- [bus\\_dump](#)
- [cache\\_size](#)
- [ipsbar](#)
- [kram\\_size](#)
- [krom\\_size](#)
- [krom\\_valid](#)
- [mbar](#)
- [mbus\\_multiplier](#)
- [memory](#)
- [sdram](#)

---

## bus\_dump

Controls dumping bus signals to the processor. `bus_dump` file. `bus_dump` switch  
`bus_dump` switch

### Parameter

switch

Boolean value `yes` (or `true`) or `no` (or `false`).

### Remarks

If environment variable `CF_REG_DUMP` is set, a `yes` or `true` switch value for this command also dumps the CPU register values to the `processor.reg_dump` file.

### Example

```
bus_dump true
```

## cache\_size

Configures the cache size.

```
cache_size size_parameter
```

### Parameter

size\_parameter

Default value 0 (off), or another code number for the size, per [Table 6.1](#).

**Table 6.1 Cache Size Parameter Conversion**

size_paramet er	Kilobytes	size_paramet er	Kilobytes
0	0	4	4
1	0.5	5	8
2	1	6	16
3	2	7	32

### Example

```
cache_size 7
```

---

## ipsbar

Provides beginning address and offset, enabling V4-core IPSBAR registers. (The V4 counterpart command is mbar.)

```
ipsbar switch
```

### Parameter

switch

Boolean value yes (or true) or no (or false).

### Example

```
ipsbar true
```



## kram\_size

Configures the KRAM size.

```
kram_size size_parameter
```

### Parameter

size\_parameter

Code number for the size, per [Table 6.2](#).

**Table 6.2 kram Size Parameter Conversion**

size_parameter	Kilobytes	size_parameter	Kilobytes
0	0	6	16
1	0.5	7	32
2	1	8	64
3	2	9	128
4	4	10	256
5	8	11	512

### Example

```
kram_size 7
```

---

## krom\_size

Configures the KROM size.

```
krom_size size_parameter
```

### Parameter

size\_parameter

Code number for the size, per [Table 6.3](#).

**Table 6.3 krom Size Parameter Conversion**

size_paramet er	Kilobytes	size_paramet er	Kilobytes
0	0	6	16
1	0.5	7	32
2	1	8	64
3	2	9	128
4	4	10	256
5	8	11	512

**Example**

```
krom_size 11
```

---

**krom\_valid**

Controls KROM mapping to address \$0 at boot-up.

```
krom_valid switch
```

**Parameter**

```
switch
```

Boolean value yes (or true) or no (or false).

**Example**

```
krom_valid true
```

---

**mbar**

Provides beginning address and offset, enabling V2-core MBAR registers. (The V4 counterpart command is ipsbar.)

```
mbar switch
```

**Parameter**

switch

Boolean value yes (or true) or no (or false).

**Example**

```
mbar true
```

---

**mbus\_multiplier**

For a V2-core processor, multiplies the core clock speed.

mbus\_multiplier value

**Parameter**

value

Any integer between 1 and 10.

**Example**

```
mbus_multiplier 10
```

---

**memory**

Configures sections of external memory.

memory start end wait\_states line\_wait\_states

**Parameters**

start

Starting address of the contiguous section of memory.

end

Ending address of the contiguous section of memory.

wait\_states

Number of wait states inserted for normal access (for V2 ISS only).

line\_wait\_states

Number of wait states inserted for line access (for V2 ISS only).

---

## Instruction Set Simulator

### Sample Configuration File

#### Remarks

There may be any number of MBUS memories, each with different *wait states* settings.

You must provide *wait\_states* and *line\_wait\_states* values for a V2 ISS, but you should not provide these values for a V4 ISS.

#### Examples

```
memory 0x00000000 0x0fffffff 0 0
memory 0x20000000 0x3000ffff 0 0
```

## sdram

Configures SDRAM.

```
sdram bank_bits num_bytes wait_states line_wait_states
```

#### Parameters

*bank\_bits*

Number of bank bits used (only two banks are allowed).

*num\_bytes*

Number of bytes allocated.

*wait\_states*

Number of wait states inserted for normal access (for V2 ISS only).

*line\_wait\_states*

Number of wait states inserted for line access (for V2 ISS only).

#### Example

```
sdram 2 0x8000 0 0
```

## Sample Configuration File

[Listing 6.1](#) shows configuration file `ColdFire2.cfg`.

### Listing 6.1 ColdFire2.cfg File Example

```
#Example Configuration File
memory 0x0000 0x7fff 0 0
```

```
kram_size 8  
bus_dump on  
sdram 2 0x8000 0 0  
ipsbar true
```

---

## ISS Limitations

These limitations apply to the ISS:

- You cannot set hardware breakpoints, because debugging is not happening on an actual hardware board.
- You cannot set watchpoints in source code.
- You cannot use the *Attach* feature while you use the ISS.
- The **Run Without Debugger** button  does not work, if you use the ISS to run your application.



**Instruction Set Simulator**  
*ISS Limitations*

---

# Using Hardware Tools

---

This chapter explains the CodeWarrior IDE hardware tools, which you can use for board bring-up, test, and analysis. These tools are not used with CCS-SIM or other simulators.

This chapter consists of these sections:

- [Flash Programmer](#)
- [Hardware Diagnostics](#)

## Flash Programmer

Use the CodeWarrior flash programmer to program target-board flash memory with code from any CodeWarrior IDE project, or with code from any individual executable files.

The flash programmer runs as a CodeWarrior plug-in, using the CodeWarrior debugger protocol API to communicate with the target boards. The CodeWarrior flash programmer lets you use the same IDE to program the flash of any of the embedded target boards.

---

**NOTE** For Special-Edition software, the CodeWarrior flash programmer is limited to 128 kilobytes. There is no such limitation for Standard-Edition or Professional-Edition software.

Each software edition also comes with an optional ColdFire flash programmer, available in subdirectory  
`\bin\Pugins\Support\Flash_Programmer` of the CodeWarrior installation directory.

---

Follow these steps:

1. Make sure to build the application you want to program into flash memory.
2. From the IDE main menu bar, select **Tools > Flash Programmer** — the **Flash Programmer** window ([Figure 7.1](#)) appears.

## Using Hardware Tools

### Flash Programmer

**Figure 7.1 Flash Programmer Window: Target Configuration Panel**

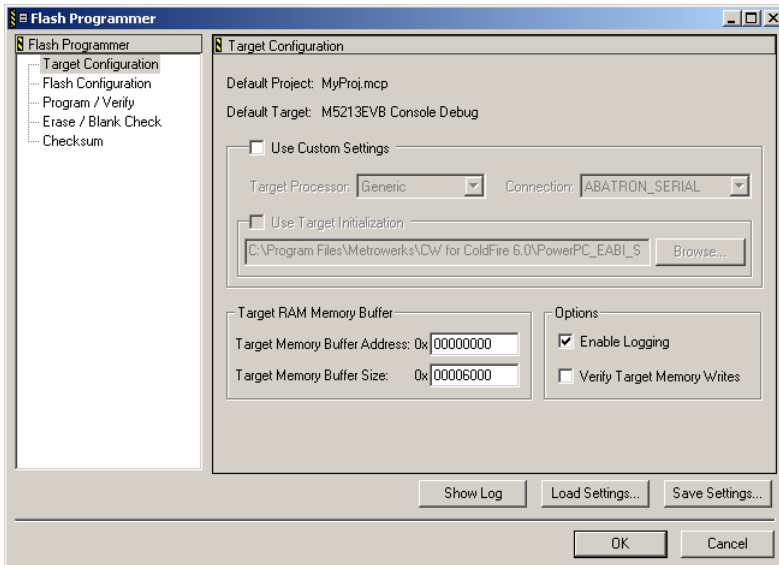

3. If the Target Configuration panel is not visible, select it from the list at the left — the panel moves to the front of the **Flash Programmer** window.
4. Verify Target Configuration settings.
  - a. If the Default Project field specifies your project, skip ahead to substep c.
  - b. Otherwise, from the main menu bar, select **Project > Set as default project** to specify your project.
  - c. If the Default Target field specifies the correct Flash target, skip ahead to substep e.
  - d. Otherwise, from the main menu bar, select **Project > Set as default target** to specify the correct Flash target.
  - e. Make sure that the Use Custom Settings checkbox is clear.
  - f. Click the **Load Settings** button. A file browser will appear.
  - g. Browse to bin\Pugins\Support\Flash\_Programmer\ColdFire and select the appropriate xml file, then press **Open** — the system updates other settings for the default project and target.
5. Configure the flash device.



- a. From the pane list at the left of the **Flash Programmer** window, select **Flash Configuration** — the Flash Configuration panel moves to the front of the window, as [Figure 7.2](#) shows.

**Figure 7.2 Flash Programmer Window: Flash Device Configuration Panel**

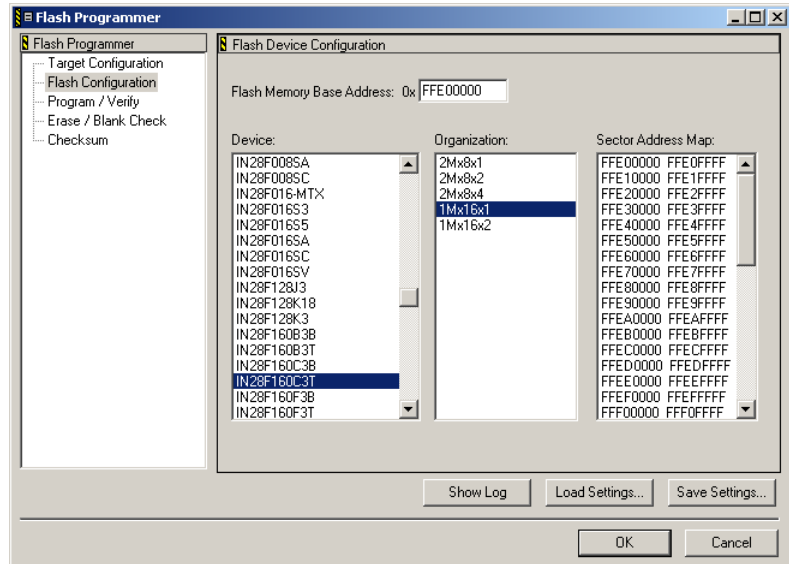

- b. Make sure that the Device list box specifies your external flash device, or the on-chip flash of your ColdFire-derivative processor.
  - c. Make sure that the Flash Memory Base Address text box specifies the appropriate base address.
  - d. The Organization and Sector Address Map boxes display appropriate additional information.
6. Erase the destination flash-memory sectors.

## Using Hardware Tools

### Flash Programmer

- a. From the pane list at the left of the **Flash Programmer** window, select **Erase/Blank Check** — the Erase/Blank Check panel moves to the front of the window, as [Figure 7.3](#) shows.

**Figure 7.3 Flash Programmer Window: Erase/Blank Check Flash Panel**

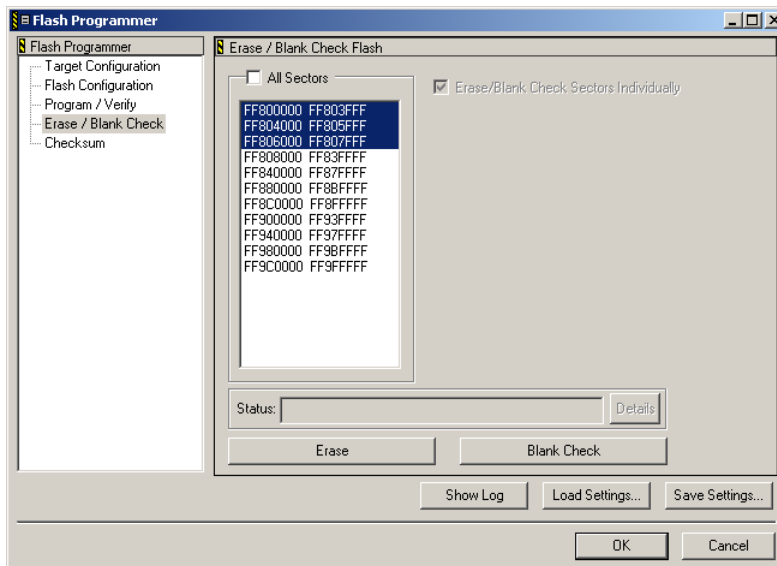

- b. In the panel's list box, select the sectors you want to erase. (To select them all, check the All Sectors checkbox.)
  - c. Click the **Erase** button — the flash programmer erases the sectors.
  - d. (Optional) To confirm erasure, select the same sectors, then click the **Blank Check** button — a message reports the status of the sectors.
7. Flash your application.

- a. From the pane list at the left of the **Flash Programmer** window, select **Program/Verify** — the Program/Verify Flash panel moves to the front of the window, as [Figure 7.4](#) shows.

**Figure 7.4 Flash Programmer Window: Program/Verify Flash Panel**

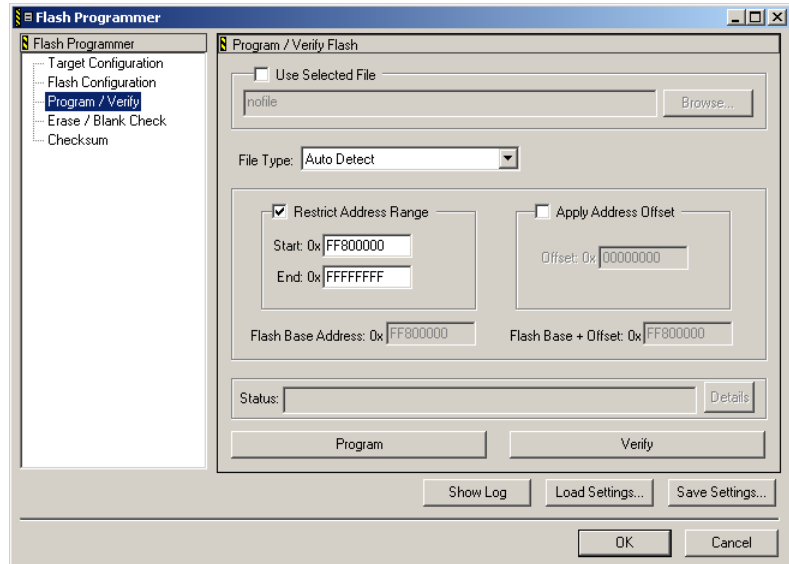

- b. Make sure that the Use Selected File checkbox is clear.
  - c. Click the **Program** button — the flash programmer programs your application into the target sectors of flash memory.
  - d. (Optional) To confirm programming, click the **Verify** button — the flash programmer compares the data now in flash sectors to the image file on disk.
8. (Optional) For an additional test of programmed flash sectors, run a checksum.

## Using Hardware Tools

### Hardware Diagnostics

- a. From the pane list at the left of the **Flash Programmer** window, select **Checksum** — the Checksum panel moves to the front of the window, as [Figure 7.5](#) shows.

**Figure 7.5 Flash Programmer Window: Checksum Panel**

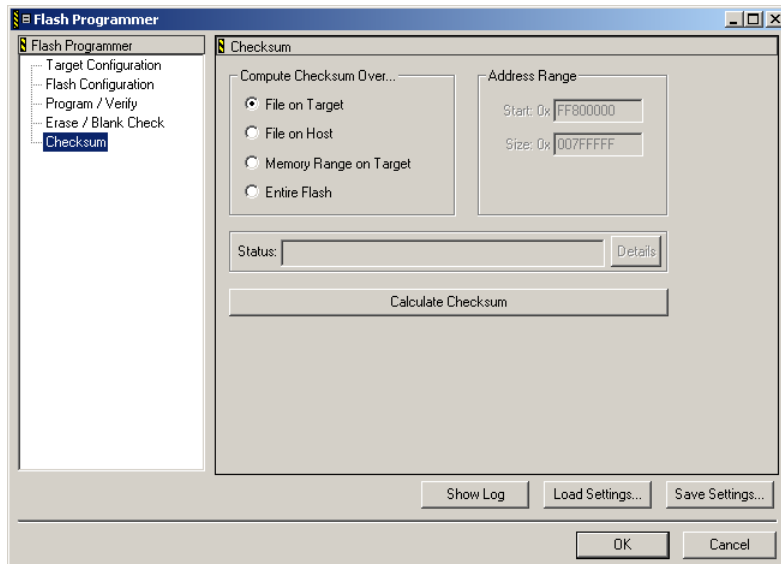

- b. In the Compute Checksum Over area, select the appropriate option button: File on Target, File on Host, Memory Range on Target, or Entire Flash.
  - c. If this selection activates the Address Range text boxes, enter the appropriate Start and Size values.
  - d. Click the **Calculate Checksum** button — the flash programmer runs the checksum calculation; a message tells you the result.
9. This completes flash programming.

## Hardware Diagnostics

Use the CodeWarrior hardware diagnostics tool to obtain several kinds of information about the target board. The Hardware Diagnostics feature is not supported by the ISS.

Select **Tools > Hardware Diagnostics** from the IDE main menu bar — the **Hardware Diagnostics** window ([Figure 7.6](#)) appears.

Figure 7.6 Hardware Diagnostics window: Configuration Panel

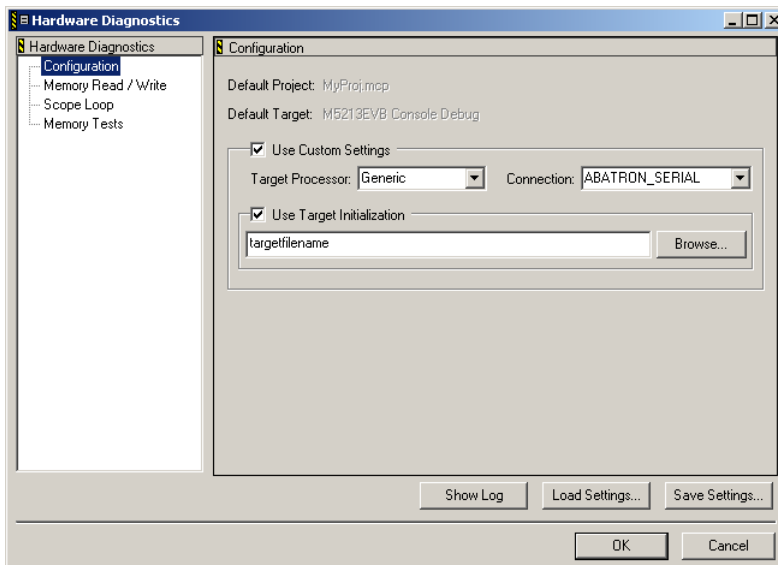

Figure 7.6 shows the Configuration panel. Click any name in the list pane to bring the corresponding panel to the front of the window:

- Memory Read/Write Test — which [Figure 7.7](#) shows.
- Scope Loop Test — which [Figure 7.8](#) shows.
- Memory Tests — which [Figure 7.9](#) shows.

**NOTE** In [Figure 7.7](#), [Figure 7.8](#), and [Figure 7.9](#), be sure to use addresses which are in the memory map for your hardware configuration (which are defined through the configuration file).

## Using Hardware Tools

### Hardware Diagnostics

**Figure 7.7 Hardware Diagnostics window: Memory Read/Write Test Panel**

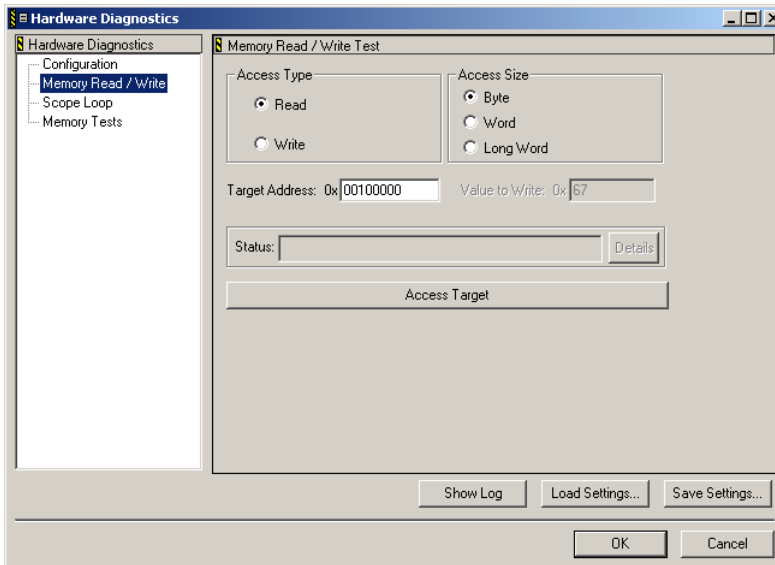

**Figure 7.8 Hardware Diagnostics window: Scope Loop Test Panel**

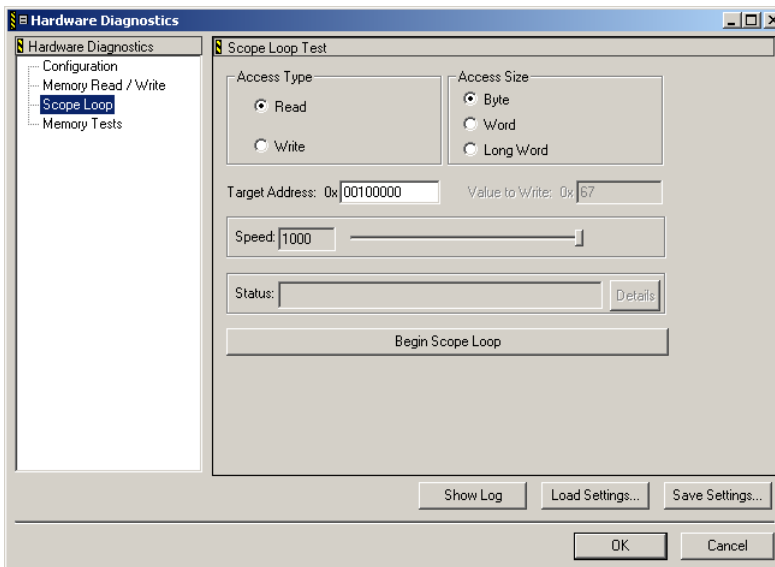
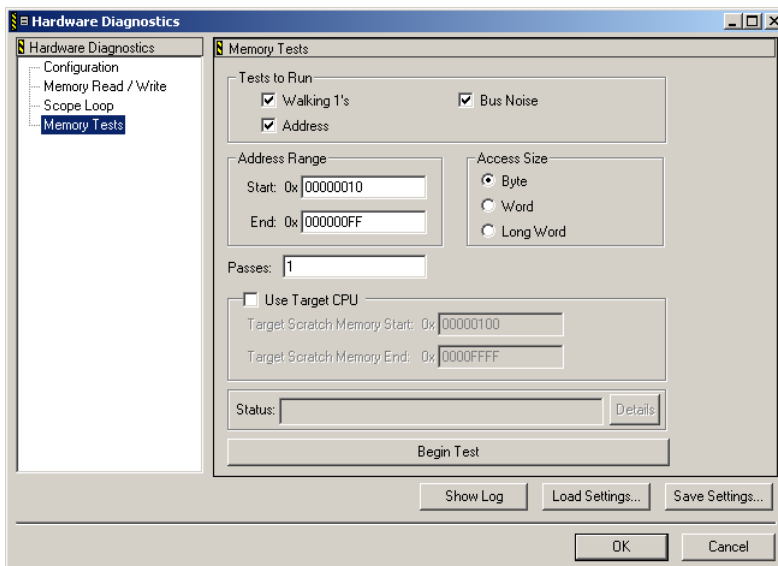

Figure 7.9 Hardware Diagnostics window: Memory Tests Panel



The **Hardware Diagnostics** window lists global options for the hardware diagnostic tools; these preferences apply to every open project file. For more information about each hardware-diagnostics panel, see the *IDE User's Guide* .



**Using Hardware Tools**  
*Hardware Diagnostics*

---



# Using Debug Initialization Files

This appendix explains background debugging mode (BDM) support for the ColdFire reference boards. BDM controls the processor, accessing both memory and I/O devices via a simple serial, *wiggler* interface. BDM can be very useful during initial debugging of control system hardware and software; it also can simplify production-line testing and end-product configuration.

Specifically, this appendix explains how to use debug initialization files with the P&E Micro wiggler. Debug initialization files contain commands that initialize the target board to write the program to memory, once the debugger starts the program.

Each time you start the debugger, and each time you select **Debug > Reset Target**, the system processes a debug initialization file. Such a file perform such functions as initializing registers and memory in targets that do not yet have initialization code in ROM.

This appendix consists of these sections:

- [Common File Uses](#)
- [Command Syntax](#)
- [Command Reference](#)

You specify whether to use a debug initialization file — and which to use — via the **ColdFire Target Settings** panel.

## Common File Uses

The most common use for debug initialization files is configuring the essential set of memory-control registers, so that downloads and other memory operations are possible. This is appropriate if your target system or evaluation board does not yet have initialization code in target ROM. It also can be an appropriate way to override an existing initialization after a reset.

To create this section of the debug initialization file, you mirror the values that the processor chip-select, pin-assignment, and other memory control registers should have after execution of initialization code. However, the set of registers that need initialization

## Using Debug Initialization Files

### Common File Uses

---

varies by processor. For details, see your processor data book, as well as the sample files in the CodeWarrior subdirectory `\E68K_Tools\Initialization_Files`.

Other uses and guidance items are:

- Sample files are specific to processor, and, in most cases, evaluation board. Use the sample templates for your own board.
- Use a debug initialization file *only* to initialize memory setup. Trying to use such a file for additional initialization, such as for on-board peripherals or setup ports, would *prevent* these other initializations during normal execution. As the program does not use BDM in normal execution, it would not initialize such peripherals, so the program could fail to execute properly.
- Put non-memory and non-exception-setup initialization instructions in the `init_hardware` function of processor startup code instead of in a debug initialization file. Another valid place for such instructions is your own start routine. These methods take care of initialization.
- Once debugging is done, your startup code must initialize the memory management unit, setting up the memory appropriately for non-debugger program execution.
- [Listing 8.1](#) is a sample BDM initialization file for the MCF5272C3 board.

#### Listing 8.1 Sample BDM Initialization file

---

```

; Set VBR to start of future SDRAM
; VBR is an absolute CPU register
; SDRAM is at 0x00000000+0x0400000
writecontrolreg 0x0801 0x00000000

; Set MBAR to 0x10000001
; MBAR is an absolute CPU register, so if
; you move MBAR, you must change all subsequent
; writes to MBAR-relative locations
writecontrolreg 0x0C0F 0x10000001

; Set SRAMBAR to 0x20000001
; SRAMBAR is an absolute CPU register, the
; location of chip internal 4k of SRAM
writecontrolreg 0x0C04 0x20000001

; Set ACR0 to 0x00000000
writecontrolreg 0x04 0x00000000

; Set ACR1 to 0x00000000

```

```
writecontrolreg 0x05    0x00000000

; 2MB FLASH on CS0 at 0xFFE00000

writemem.1 0x10000040 0xFFE00201
writemem.1 0x10000044 0xFFE00014

; CS7 4M byte SDRAM
; Unlike 5307 and 5407 Cadre 3 boards,
; the 5272 uses CS7 to access SDRAM

writemem.1 0x10000078 0x00000701
writemem.1 0x1000007C 0xFFC0007C

; Set SDRAM timing and control registers
; SDCTR then SDCCR

writemem.1 0x10000184 0x0000F539
writemem.1 0x10000180 0x00004211

; Wait a bit

delay 600

writemem.1 0x10000000 0xDEADBEEF

; Wait a bit more

delay 600
```

---

## Command Syntax

The syntax rules for commands in a debug initialization file are:

- The system ignores space characters and tabs.
- The system ignores character case in commands.
- Numbers may be in hexadecimal, decimal, or octal format:
  - Hexadecimal values must start with 0x, as in 0x00002222, 0xA, or 0xCAfeBeAD.
  - Decimal values must start with a numeral 1 through 9, as in 7, 12, 526, or 823643.
  - Octal values must start with a zero, as in 0123, or 0456.

## Using Debug Initialization Files

### Command Reference

---

- Start comments with a colon (;), or pound sign (#). Comments end at the end of the line.

## Command Reference

This section explains the commands valid for debug initialization files:

- [Delay](#)
- [ResetHalt](#)
- [ResetRun](#)
- [Stop](#)
- [writeaddressreg](#)
- [writecontrolreg](#)
- [writedatareg](#)
- [writemem.b](#)
- [writemem.l](#)
- [writemem.w](#)

---

**NOTE** Old data initialization files that worked with a Macraigor interface may not work with a P&E interface because command `writereg SPRnn` changed to `writecontrolreg 0xNNNN`. Please update files accordingly.

---



---

## Delay

Delays execution of the debug initialization file for the specified time.

Delay <time>

### Parameter

time

Number of milliseconds to delay.

### Example

This example creates a half-second pause in execution of the debug initialization file:

```
Delay 500
```

## ResetHalt

Resets the target, putting the target in debug state.

```
ResetHalt
```

---

## ResetRun

Resets the target, letting the target execute from memory.

```
ResetRun
```

---

## Stop

Stops program execution, putting the target in a debug state.

```
Stop
```

---

## writeaddressreg

Writes the specified value to the specified address register.

```
writeaddressreg <registerNumber> <value>
```

### Parameters

`registerNumber`

Any integer, 0 through 7, representing address register A0 through A7.

`value`

Any appropriate register value.

### Example

This example writes hexadecimal `ff` to register A4:

```
writeaddressreg 4 0xff
```

### writecontrolreg

Writes the specified value to the address of a control register.

```
writecontrolreg <address> <value>
```

*address* is the address of the control register.

#### Parameters

*address*

Address of any control register.

*value*

Any appropriate value.

#### Example

This example writes hexadecimal `c0f` to control-register address `20000001`:

```
writecontrolreg 0xc0f 0x20000001
```

---

### writedatareg

Writes the specified value to the specified data register.

```
writedatareg <registerNumber> <value>
```

#### Parameters

*registerNumber*

Any integer, 0 through 7, representing data register D0 through D7.

*value*

Any appropriate register value.

#### Example

This example writes hexadecimal `ff` to register D3:

```
writedatareg 3 0xff
```

## writemem.b

Writes the specified byte value to the specified address in memory.

```
writemem.b <address> <value>
```

### Parameters

address

One-byte memory address.

value

Any one-byte value.

### Example

This example writes decimal 255 to memory decimal address 2345:

```
writemem.b 2345 255
```

---

## writemem.l

Writes the specified longword value to the specified address in memory.

```
writemem.l <address> <value>
```

### Parameters

address

Four-byte memory address.

value

Any four-byte value.

### Example

This example writes hexadecimal 00112233 to memory hexadecimal address 00010000:

```
writemem.l 0x00010000 0x00112233
```

---

## Using Debug Initialization Files

### Command Reference

---

---

#### writemem.w

Writes the specified word value to the specified address in memory.

```
writemem.w <address> <value>
```

#### Parameters

address

Two-byte memory address.

value

Any two-byte value.

#### Example

This example writes hexadecimal 12ac to memory hexadecimal address 00010001:

```
writemem.w 0x00010001 0x12ac
```



# Memory Configuration Files

---

In your overall memory map, there can be *gaps* or *holes* between physical memory devices. If the debugger tries a read or write to an address in such a hole, the system would issue an error message, and debugging might not even be possible.

To prevent such developments, use a memory configuration file (MCF). An MCF identifies valid memory address ranges to the debugger, and even specifies valid access types.

---

**NOTE** The memory configuration file for your project should be updated to the latest memory configuration file for your hardware configuration. Up-to-date memory files can be found in  
`\E68K_Support\Initialization_Files.`

---

A sample memory configuration file is  
`\E68K_Support\Initialization_Files\MCF5485EVB.mem` of the CodeWarrior installation directory.

This appendix consists of these sections:

- [Command Syntax](#)
- [Command Explanations](#)

## Command Syntax

The syntax rules for commands in a memory configuration file are:

- The system ignores space characters and tabs.
- The system ignores character case in commands.
- Numbers may be in hexadecimal, decimal, or octal format:
  - Hexadecimal values must start with 0x, as in 0x00002222, 0xA, or 0xCAfeBeAD.
  - Decimal values must start with a numeral 1 through 9, as in 7, 12, 526, or 823643.
  - Octal values must start with a zero, as in 0123, or 0456.
- Comments can be in standard C or C++ format.

# Command Explanations

This section explains the commands you can use in a memory configuration file:

- [range](#)
- [reserved](#)
- [reservedchar](#)

---

## range

Specifies a memory range for reading or writing.

```
range <loAddr> <hiAddr> <sizeCode> <access>
```

### Parameters

loAddr

Starting address of memory range.

hiAddr

Ending address of memory range.

sizeCode

Size, in bytes, for memory accesses by the debug monitor or emulator.

access

Read, Write, or ReadWrite.

### Example

These range commands specify three adjacent ranges: the first read-only, with 4-byte access; the second write-only, with 2-byte access; and the third read/write, with 1-byte access.

```
range    0xFF000000 0xFF0000FF 4 Read
range    0xFF000100 0xFF0001FF 2 Write
range    0xFF000200 0xFFFFFFFF 1 ReadWrite
```

## reserved

Reserves a range of memory, preventing reads or writes.

```
reserved <loAddr> <hiAddr>
```

### Parameters

loAddr

Starting address of reserved memory range.

hiAddr

Ending address of reserved memory range.

### Remarks

If the debugger tries to write to any address in the reserved range, no write takes place.

If the debugger tries to read from any address in the reserved range, the system fills the memory buffer with the reserved character. (Command `reservedchar` defines this reserved character.)

### Example

This command prevents reads or writes in the range 0xFF00024 — 0xFF0002F:

```
reserved 0xFF00024 0xFF0002F
```

---

## reservedchar

Specifies a reserved character for the memory configuration file.

```
reservedchar <char>
```

### Parameter

char

Any one-byte character.

### Remarks

If an inappropriate read occurs, the debugger fills the memory buffer with this reserved character.

---



## Memory Configuration Files

### *Command Explanations*

---

#### **Example**

```
reservedchar 0xBA
```

# Index

## A

- Abatron
  - BDI connection 83, 85
  - remote connections 71–73
- application development diagram 16
- application tutorial 21–32

## B

- batchrunner postlinker settings panel 37
- batchrunner prelinker settings panel 37
- BDM debugging 83, 85
- build settings panel 85
- building 18, 19
- building a project 25, 27
- bus\_dump simulator configuration command 95

## C

- cache\_size simulator configuration command 96
- CF
  - debugger settings panel 27, 56–59
  - exceptions panel 63–66
  - interrupt panel 68
- checksum panel 108
- CodeWarrior
  - development process 15–20
  - IDE 14
- ColdFire
  - assembler panel 38–41
  - linker panel 48–53
  - processor panel 45–48
  - settings panels 34–53
  - target panel 38
- commands
  - debug initialization files 116–120
  - memory configuration files 122–124
  - simulator configuration 94–100
- compiling 18, 19
- configuration files, memory 121–124
- configuration panel 109
- connections
  - Abatron BDI 83, 85

- remote 61–63

- wiggler 83

- console window 32

- creating a project 21–24

## D

- debug initialization files 113–120
  - commands 116–120
    - Delay 116
    - ResetHalt 117
    - ResetRun 117
    - Stop 117
    - writeaddressreg 117
    - writecontrolreg 118
    - writedatareg 118
    - writemem.b 119
    - writemem.l 119
    - writemem.w 120
  - syntax 115
  - uses 113–115
- debugger PIC settings 53
- debugger settings panel 66, 68
- debugger window 28
- debugging 19, 55–90
  - Abatron remote connections 71–73
  - an application 27–32
  - BDM debugging 83, 85
    - connecting a wiggler 83
    - connecting Abatron BDI 83, 85
  - ELF files 85–88
    - customizing XML file 86, 87
    - IDE preferences 85, 86
  - Freescale remote connections 73–76
  - ISS remote connection 80–82
  - P&E Micro remote connections 76–80
  - remote connections 69–82
  - simple profiler 90
  - special features 88–90
  - target settings 55–69
    - CF debugger settings panel 56–59
    - CF exceptions panel 63–66
    - CF interrupt panel 68

---

- debugger settings panel 66, 68
- remote connections 61–63
- remote debugging panel 59–61
- Delay debug initialization command 116
- development process, CodeWarrior 15–20
- dialog boxes
  - new 22
  - new connection 62
  - new project 23
- disassembling 19
- documentation 10, 11

## E

- editing 18
- editions 8, 9
- editor window 18
- ELF
  - disassembler panel 41–44
  - files
    - customizing XML file 86, 87
    - debugging 85–88
    - IDE preferences 85, 86
- erase/blank check flash panel 106

## F

- features 7, 8
- features, simulator 91–93
- files
  - debug initialization 113–120
  - memory configuration 121–124
  - project 17
- flash device configuration panel 105
- flash programmer 103–108
- flash programmer window 104–108
- Freescale
  - remote connections 73–76

## G

- getting started 13–20
- global settings panel 86

## H

- hardware diagnostics 108–111

- hardware diagnostics window 109–111
- hardware tools 103–111
  - flash programmer 103–108
  - hardware diagnostics 108–111

## I

### IDE

- CodeWarrior 14
- preferences, updating 85, 86
- IDE preferences window 62
- instruction set simulator 91–101
  - limitations 101
  - sample configuration file 100
- introduction 7–11
- ipsbar simulator configuration command 96

### ISS

- configuration commands 94–100
  - bus\_dump 95
  - cache\_size 96
  - ipsbar 96
  - kram\_size 97
  - krom\_size 97, 98
  - krom\_valid 98
  - mbar 98, 99
  - mbus\_multiplier 99
  - memory 99, 100
  - sdram 100
- features 91–93
- remote connection 80–82

## K

- kram\_size simulator configuration command 97
- krom\_size simulator configuration command 97, 98
- krom\_valid simulator configuration command 98

## L

- limitations, simulator 101
- linking 18, 19

## M

- main window 22
- mbar simulator configuration command 98, 99

---

mbus\_multiplier simulator configuration

command 99

memory configuration files 121–124

commands 122–124

range 122

reserved 123

reservedchar 123, 124

syntax 121

memory read/write test panel 110

memory simulator configuration command 99,  
100

memory tests panel 111

## N

new connection dialog box 62

new dialog box 22

new project dialog box 23

## O

overview, target settings 33, 34

## P

P&E Micro remote connections 76–80

panels

batchrunner postlinker 37

batchrunner prelinker 37

build settings 85

CF debugger settings 27, 56–59

CF exceptions 63–66

CF interrupt 68

checksum 108

ColdFire assembler 38–41

ColdFire linker 48–53

ColdFire processor 45–48

ColdFire settings 34–53

ColdFire target 38

configuration 109

debugger settings 66, 68

ELF disassembler 41–44

erase/blank check flash 106

flash device configuration 105

global settings 86

memory read/write test 110

memory tests 111

program/verify flash 107

remote connections 62

remote debugging 26, 59–61

scope loop tests 110

target configuration 104

target setting 35–36

target settings 25

PIC

settings 53

profiler 90

program/verify flash panel 107

project

building 25, 27

creating 21–24

debugging 27–32

files 17

window 17

project window 24

## R

range memory configuration command 122

registers window 30, 94

remote connections 61–63

debugging 69–82

panel 62

remote debugging panel 26, 59–61

requirements, system 13, 14

reserved memory configuration command 123

reservedchar memory configuration

command 123, 124

ResetHalt debug initialization command 117

ResetRun debug initialization command 117

## S

sample code

transitive closure 52, 53

sample ISS configuration file 100

scope loop tests panel 110

sdram simulator configuration command 100

settings

panels 34–53

target 33–53

target, debugging 55–69

---

- simple profiler 90
- simulator 91–101
- simulator configuration commands 94–100
- simulator, using 93, 94
- software editions 8, 9
- special features, debugging 88–90
- starting 13–20
- Stop debug initialization command 117
- syntax
  - debug initialization files 115
  - memory configuration files 121
- system requirements 13, 14

## T

- target configuration panel 104
- target settings 33–53
  - debugging 55–69
  - overview 33, 34
  - panel 35–36
  - window 34, 56
- target settings panel 25
- target settings window 25, 26
- tools
  - flash programmer 103–108
  - hardware 103–111
  - hardware diagnostics 108–111
- transitive closure sample code 52, 53
- tutorial 21–32

## U

- USB TAP 73–76
- uses for debug initialization files 113–115
- using the simulator 93, 94

## V

- view memory window 31

## W

- wiggler connection 83
- windows
  - console 32
  - debugger 28
  - editor 18

- flash programmer 104–108
- hardware diagnostics 109–111
- IDE preferences 62
- main 22
- project 17, 24
- register 30, 94
- target settings 25, 26, 34, 56
- view memory 31
- writeaddressreg debug initialization command 117
- writecontrolreg debug initialization command 118
- writedatareg debug initialization command 118
- writemem.b debug initialization command 119
- writemem.l debug initialization command 119
- writemem.w debug initialization command 120

## X

- XML file, customizing 86, 87