

M68360QUADS Hardware User's Manual

Revision 1

August 16, 1993

CHAPTER 1 - GENERAL INFORMATION

1.1 INTRODUCTION

This manual provides general information, preparation for use and installation instructions, operating instructions, functional description, and support information for the M68360QUADS QUICC Application Development System board.

1.2 FEATURES

The main features of the QUADS board are as follows:

- Master QUICC MC68360 with 32-bit address, 32 or 16 bit data, 25 MHz.
- 1 Mbyte Dynamic RAM, 36 bits wide (data and parity) SIMM.
- 128 Kbyte boot EPROM, 8 bits wide.
- 512 Kbyte Flash Memory, 32 bits wide.
- 256 byte serial EEPROM.
- Application Development Interface (ADI) port connector.
- Serial port with RS-232 connector to terminal or to host computer.
- AppleTalk serial connector.
- BDM Controller capability for external QUICC device.
- Ethernet interface (twisted-pair and AUI) using Motorola MC68160.
- Expansion connectors providing all the signals of the master QUICC.
- Logic analyzer connectors compatible with HP logic analyzers.
- BDM connector for the master QUICC.
- Slave QUICC (core disabled) providing the following functions:
 1. DRAM Controller
 2. Chip Select and DSACK~ generator.
 3. Parallel port (ADI).
 4. UART for terminal or host computer connection.
 5. AppleTalk controller for MacIntosh computer connection.
 6. BDM controller to other QUICC devices.
 7. Ethernet controller.
 8. Serial EEPROM interface.
 9. General Purpose I/O signals.
- HARD RESET, SOFT RESET, and ABORT switches.
- Status LEDs for RUN, HALT, and Ethernet interface.
- 5Vdc and 12Vdc power supply.

1.3 SPECIFICATIONS

The M68360QUADS specifications are given in Table 1-1. Paragraph 1.4 details the cooling requirements.

Table 1-1 M68360QUADS Specifications

CHARACTERISTICS	SPECIFICATIONS
Power requirements (no other boards attached)	+5Vdc @ 3.5 A (typical), 5 A (maximum) +12Vdc @ 1 A (maximum)
Microprocessor	MC68360 @ 25 MHz
Addressing Total address range (on and off-board) Boot EPROM Flash Memory Dynamic RAM EEPROM	4 gigabytes 128 KByte, 8 bits wide 512 KByte, 32 bits wide 1 MByte, 36 bits wide SIMM (32 bit data, 4 bit parity) option to use higher density SIMM, up to 8 MByte 256 Byte, serial EEPROM
Operating temperature	0 degrees to 30 degrees C ambient air temperature
Storage temperature	-25 degrees to 85 degrees C
Relative humidity	5% to 90% (non-condensing)
Dimensions Height Depth Thickness	9.173 inches (233 mm) 7.087 inches (180 mm) 0.063 inches (1.6 mm)

1.4 COOLING REQUIREMENTS

The M68360QUADS is specified, designed, and tested to operate reliably within an ambient air temperature range from 0 degrees C to 70 degrees C. Dynamic Burn-in is performed while the board is table mounted with no other boards attached to it. Test software is executed as the board is subjected to temperature variations.

If the board is attached to other boards, the thermal conditions may get worse and it is recommended that the operating temperature should not exceed 30 degrees C.

1.5 GENERAL DESCRIPTION

The M68360QUADS is a development tool for the MC68360 QUICC device. This board is used for hardware and software development of applications using the QUICC device, such as Ethernet interface or other communication boards.

The M68360QUADS has logic analyzer connectors and expansion connectors, providing physical connection to all pins of the master QUICC on the board. The logic analyzer connectors enable the user to monitor the bus activity and the I/O pins of the QUICC, by providing direct connection to HP or other logic analyzers. The expansion connectors enable to attach user applications to the board, and use the board hardware and software resources to check the user application.

The M68360QUADS has Ethernet and LocalTalk ports, which enable the user to develop and test the software on the board, before integrating it on the application.

1.6 RELATED DOCUMENTATION

The following publications are applicable to the M68360QUADS and may provide additional helpful information.

- MC68360 QUICC User's Manual.
- MC68160 EEST User's Manual.

1.7 ABBREVIATIONS USED IN THE DOCUMENT

- QUICC - QUad Integrated Communications Controller MC68360 device.
- EEST - Enhanced Ethernet Serial Transceiver MC68160 device.
- QUADS - Application Development System for the QUICC device.
- ADI - Application Development Interface.
- UART - Universal Asynchronous Receiver/Transmitter.
- BDM - Background Debug Mode.
- SIMM - Single In-line Memory Module.
- AUI - Attachment Unit Interface.
- TP - Twisted Pair.
- spec - Engineering specification document.
- nsec - nano second.
- μ sec - micro second.
- NMI - Non Maskable Interrupt.

1.8 REQUIRED EQUIPMENT

The M68360QUADS can operate in two working environments:

- Host controlled
- Stand-alone

In both operating modes, it is possible to use only 5V power supply. The 12V power supply is required only if desired on the AUI port or when programming the Flash Memory. (Most AUI Hubs do not require 12 V supplies to be provided by the network termination equipment).

1.8.1 Host controlled setup

FIGURE 1-1 describes the setup of the host controlled mode of operation. The required equipment in this mode is as follows:

- +5 V 5 A power supply
- +12 V 1 A power supply (optional)
- Host Computer, one of the following:
 - o Sun - 4 (SBus interface)
 - o IBM-PC/XT/AT
- ADI board - compatible with the host computer
- 37 line flat cable with female 37 pin D-type connectors on each end

FIGURE 1-1 Host Controlled Configuration

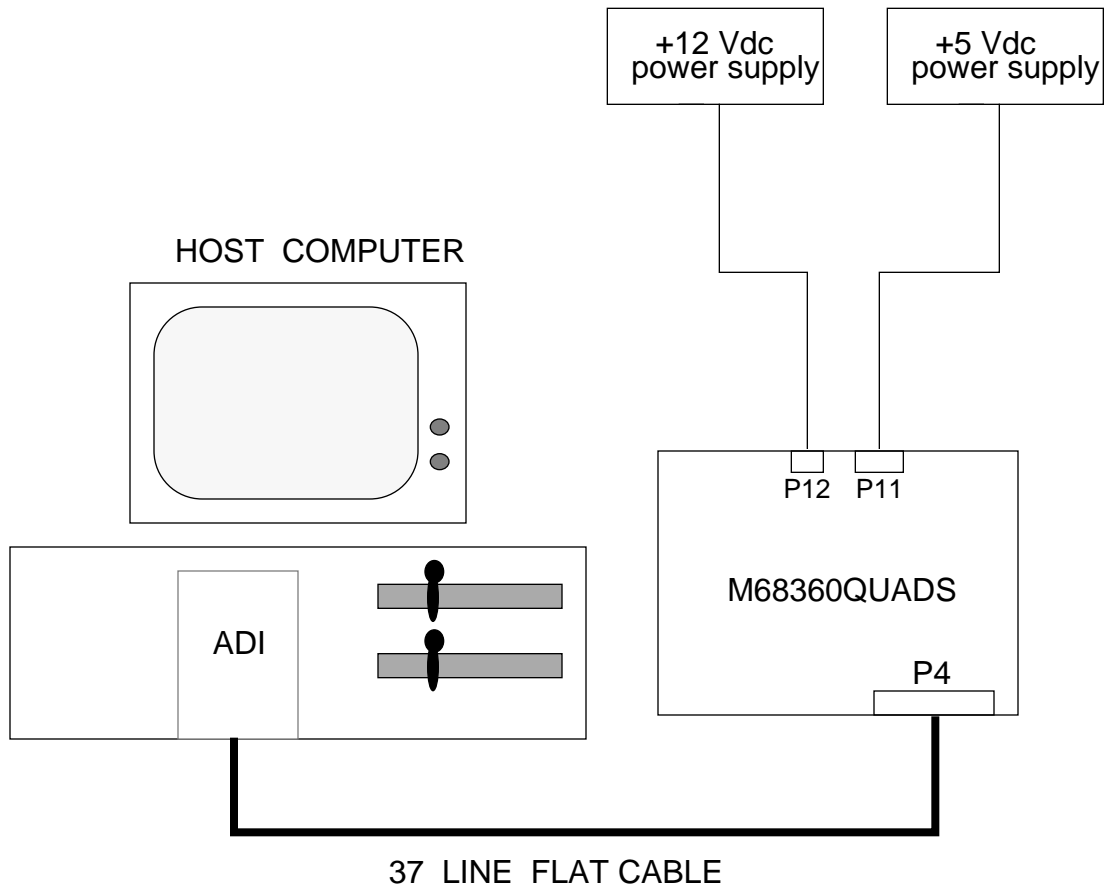

1.8.2 Stand alone setup

FIGURE 1-2 describes the setup of the stand-alone mode of operation. The required equipment in this mode are as follows:

- +5 V 5 A power supply
- +12 V 1 A power supply (optional)
- VT100 compatible terminal
- RS-232 cable with male 9 pin D-type connector on the QUADS side.

FIGURE 1-2 Stand-alone Configuration

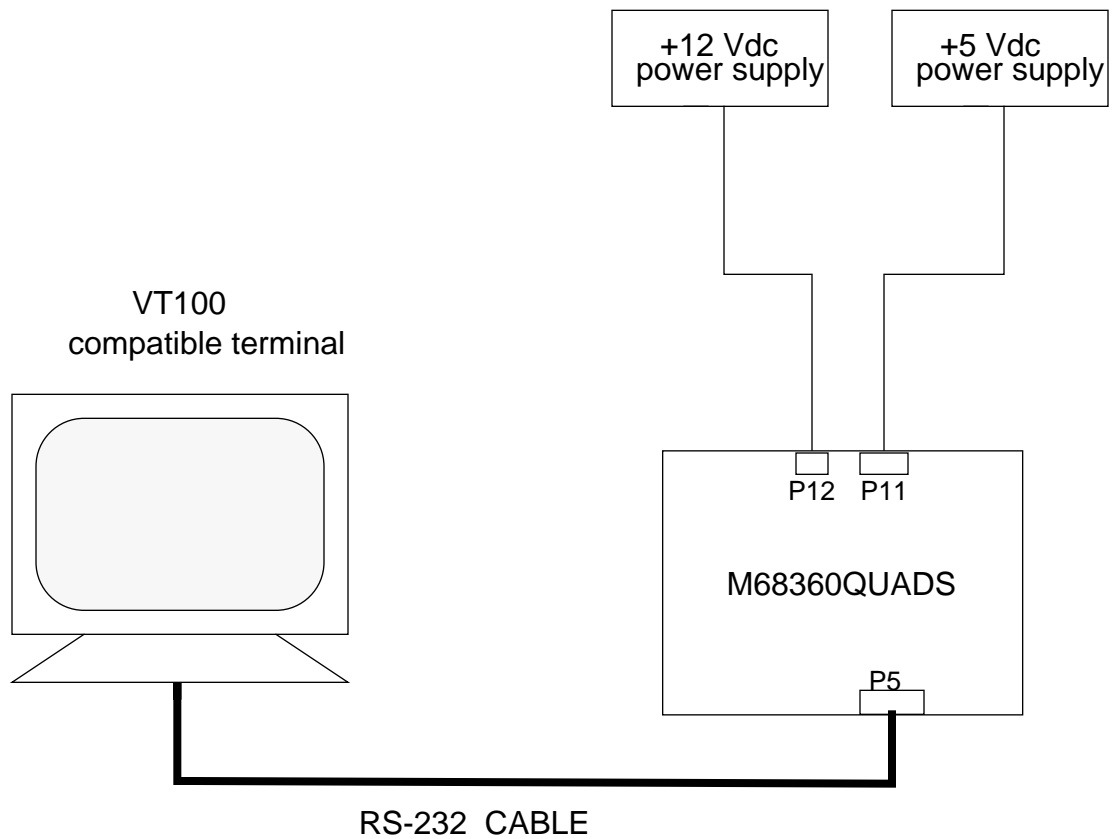

CHAPTER 2 - HARDWARE PREPARATION AND INSTALLATION

2.1 INTRODUCTION

This chapter provides unpacking instructions, hardware preparation, and installation instructions for the M68360QUADS.

2.2 UNPACKING INSTRUCTIONS

NOTE

If the shipping carton is damaged upon receipt, request carrier's agent be present during unpacking and inspection of equipment.

Unpack equipment from shipping carton. Refer to packing list and verify that all items are present. Save packing material for storing and reshipping of equipment.

CAUTION

AVOID TOUCHING AREAS OF INTEGRATED CIRCUITRY; STATIC DISCHARGE CAN DAMAGE CIRCUITS.

2.3 HARDWARE PREPARATION

To select the desired configuration and ensure proper operation of the M68360QUADS board, changes of the Dip-Switch settings may be required before installation. The location of the switches, LEDs, Dip-Switches, and connectors is illustrated in FIGURE 2-1. The board has been factory tested and is shipped with Dip-Switch settings as described in the following paragraphs. Parameters can be changed for the following conditions:

- ADI port address (Dip-Switch U46).
- Enable/Disable of the following devices on the QUADS (Dip-Switch U52):
 - Slave QUICC
 - EPROM
 - DRAM
 - Flash Memory
 - Clock Generator
 - Interrupt Generator
- Operation mode of the Master QUICC (Dip-Switch U52):
 - Configuring A(31:28) as address lines or write enables.
 - Data bus width, 32 or 16 bits.

FIGURE 2-1 M68360QUADS Location diagram

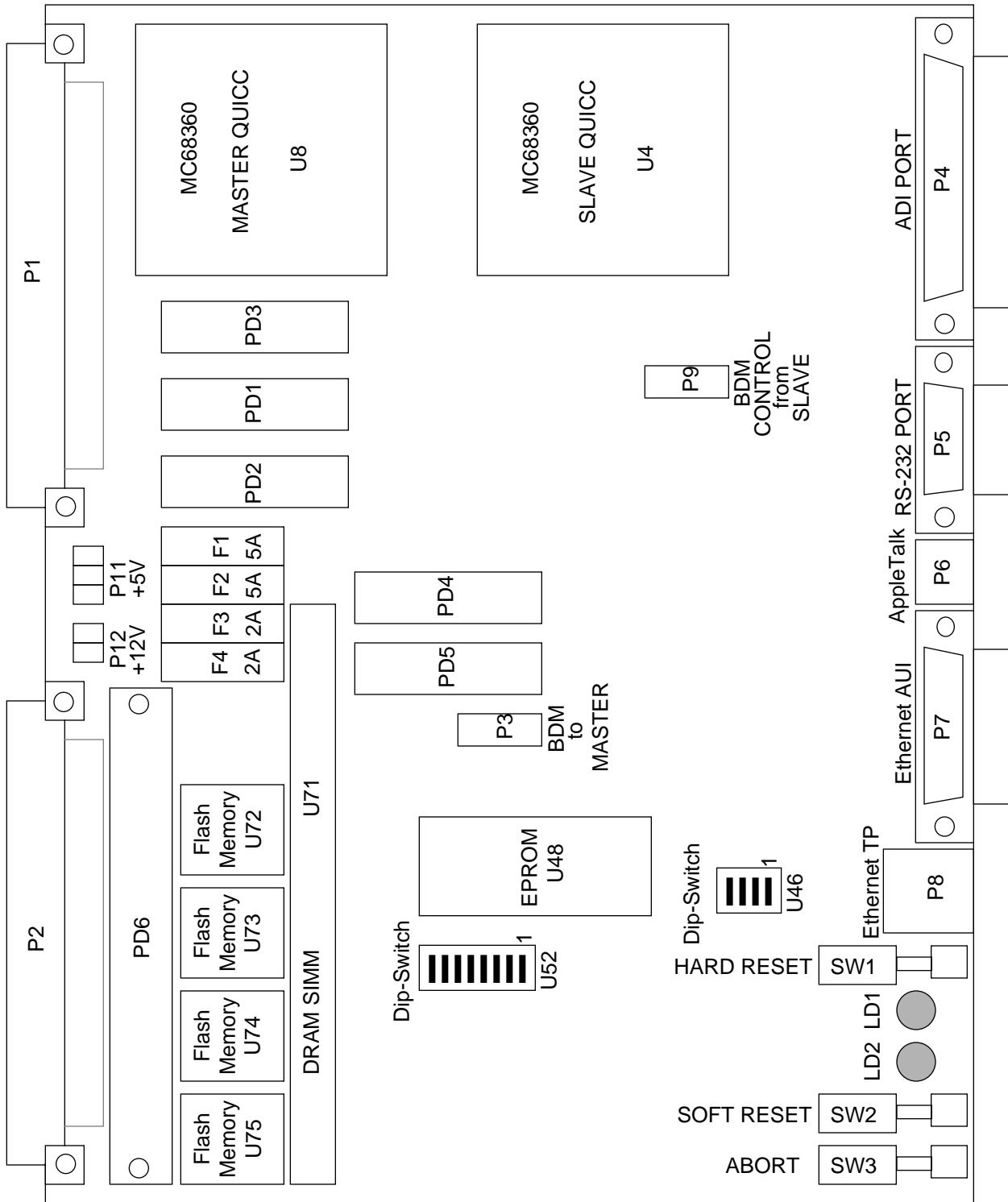

2.3.1 ADI Port Address Selection (Dip-Switch U46)

Each M68360QUADS can have eight possible slave addresses set for its ADI port, enabling up to eight M68360QUADS boards to be connected to the same ADI board in the host computer. The selection of the slave address is done by setting switches 1, 2, and 3 in the Dip-Switch. Switch 4 is reserved for future use and it should be in 'OFF' state. Switch 3 stands for the most-significant bit of the address and switch 1 stands for the least-significant bit. If the switch is in the 'ON' state, it stands for logical '1'.

FIGURE 2-2 Dip-Switch configuration for address 0

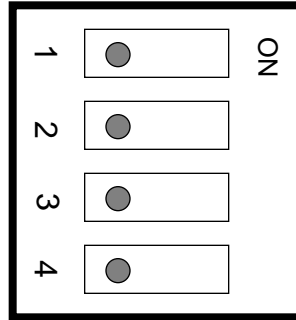

U46

Table 2-1 describes the switch settings for each slave address:

Table 2-1 ADI Address Selection

ADDRESS	Switch 3	Switch 2	Switch 1
0	OFF	OFF	OFF
1	OFF	OFF	ON
2	OFF	ON	OFF
3	OFF	ON	ON
4	ON	OFF	OFF
5	ON	OFF	ON
6	ON	ON	OFF
7	ON	ON	ON

2.3.2 QUADS Operation Mode Configuration (Dip-Switch U52)

Dip-Switch U52 has 8 switches, which are responsible for configuring the operation mode of the master QUICC on the M68360QUADS, and they also enable devices on the QUADS.

Table 2-2 describes the function of each switch.

Table 2-2 Dip-Switch U52 Description

Switch	Function	Default setting
1	Enable EPROM - This switch connects between the EPROM chip-select input and the master QUICC CS0~ signal. If the signal CS0~ is used by external logic connected to the expansion connectors, the switch must be set to OFF to disable the EPROM on the QUADS. The switch must be set to ON otherwise.	ON
2	Enable slave QUICC - This switch connects between the slave QUICC MBRE~ input pin and data signal D30. This switch is for factory testing of the QUADS, and it must be set to ON during normal operation.	ON
3	Enable DRAM - This switch indicates to the master QUICC whether to initialize the DRAM control registers or not. If the switch is ON, the DRAM on the QUADS is enabled. If the switch is OFF, the DRAM is disabled, and its memory space is free for the user. This is useful if the user needs to connect his application to the QUADS expansion connectors and use the DRAM memory space in the application.	ON
4	Enable Flash Memory - This switch indicates to the master QUICC whether to initialize the Flash Memory control registers or not. If the switch is ON, the Flash Memory on the QUADS is enabled. If the switch is OFF, the Flash Memory is disabled, and its memory space is free for the user. This is useful if the user needs to connect his application to the QUADS expansion connectors and use the Flash Memory space in the application.	ON
5	A(31:28) Configuration - This switch indicates to the CPU32bug software whether to configure the master QUICC A(31:28) pins as address lines or as write enable signals. If the switch is ON, the pins are configured as address lines. If the switch is set to OFF, the pins are configured as write enable signals.	ON
6	Enable Clock - This switch enables the clock generator on the QUADS. If it is set to ON, the 25 MHz clock generator is enabled. If it is set to OFF, the clock generator driver is disabled, and the user must supply clock to the QUADS through pins CLK1 and CLK2 in the expansion connectors.	ON
7	Enable Interrupt - When this switch is set to ON, it enables the slave QUICC interrupt generator to drive the master QUICC interrupt input pins. If the switch is set to OFF, the interrupts to the master QUICC are disabled. The master QUICC internal interrupt sources are not affected by the position of this switch. The user application can drive the master QUICC interrupt pins through the expansion connectors. When the switch is set to OFF, all external interrupts to the master QUICC can only be generated by the user application.	ON

Freescale Semiconductor, Inc.

Table 2-2 Dip-Switch U52 Description

Switch	Function	Default setting
8	<p>Data Bus Configuration - This switch is connected to signal MPRTY3 of the master QUICC. The level of this signal during hard reset determines the data bus size of the master QUICC. If the switch is set to OFF, the bus size is 32 bits. If it is set to ON, the bus size is 16 bits.</p> <p>In 16 bit mode, interrupt vectors from the slave QUICC do not pass to the master QUICC, and the auto-vector function must be used.</p> <p>Note: Power off the QUADS before setting this switch to ON.</p>	OFF

2.4 INSTALLATION INSTRUCTIONS

When the M68360QUADS has been configured as desired by the user, it can be installed according to the required working environment as follows:

2.4.1 +5V Power Supply Connection

The M68360QUADS requires +5 Vdc @ 5 A max, power supply for operation. The QUADS has 5A fuses on the +5V and its ground, and it is protected against reverse connection of the power supply. Connect the +5V power supply to connector P11 as shown below:

FIGURE 2-3 P11: +5V Power Connector

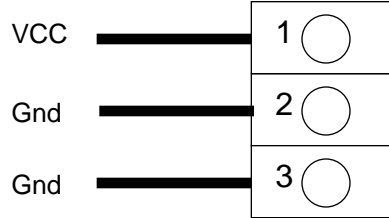

P11 is a 3 terminal block power connector with power plug. The plug is designed to accept 14 to 22 AWG wires. It is recommended to use 14 to 18 AWG wires. To insure solid ground, two Gnd terminals are supplied. It is recommended to connect both Gnd wires to the common of the power supply, while VCC is connected with a single wire.

NOTE

Since hardware applications can be connected to the M68360QUADS using the expansion connectors P1 and P2, the additional power consumption should be taken into consideration when a power supply is connected to the QUADS.

2.4.2 +12V Power Supply Connection

The M68360QUADS requires +12 Vdc @ 1 A max, power supply for the Ethernet AUI port, and for programming the Flash Memory devices. The QUADS can work properly without the +12V power supply, if the AUI port is not in use or if the AUI port is used with an AUI hub that does not require 12 V to be provided by the network termination equipment, and if there is no need to reprogram the Flash Memory.

The QUADS has 2A fuses on the +12V and its ground, and it is protected against reverse connection of the +12V power supply. Connect the +12V power supply to connector P12 as shown below:

FIGURE 2-4 P12: +12V Power Connector

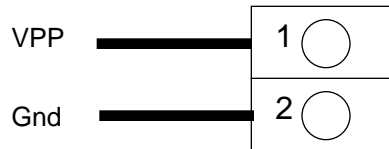

P12 is a 2 terminal block power connector with power plug. The plug is designed to accept 14 to 22 AWG wires. It is recommended to use 14 to 18 AWG wires.

2.4.3 ADI Installation

For ADI installation on various host computers, refer to APPENDIX A - on page 54.

2.4.4 Host computer to M68360QUADS Connection

The M68360QUADS ADI interface connector, P4, is a 37 pin, male, D type connector. The connection between the M68360QUADS and the host computer is by a 37 line flat cable, supplied with the ADI board. FIGURE 2-5 below shows the pin configuration of the connector.

FIGURE 2-5 ADI Port Connector

Gnd	20	1	INT_ACK
Gnd	21	2	N.C.
Gnd	22	3	HST_ACK
Gnd	23	4	ADS_ALL
Gnd	24	5	ADS_RESET
Gnd	25	6	ADS_SEL2
(+ 12 v) N.C.	26	7	ADS_SEL1
HOST_VCC	27	8	ADS_SELO
HOST_VCC	28	9	HOST_REQ
HOST_VCC	29	10	ADS_REQ
HOST_ENABLE~	30	11	ADS_ACK
Gnd	31	12	ADS_INT
Gnd	32	13	HOST_BRK~
Gnd	33	14	ADS_BRK
PD0	34	15	N.C.
PD2	35	16	PD1
PD4	36	17	PD3
PD6	37	18	PD5
		19	PD7

NOTE: Pin 26 on the ADI is connected to +12 v power supply, but it is not used in the QUADS.

2.4.5 Terminal to M68360QUADS RS-232 Connection

In the stand-alone operation mode, a VT100 compatible terminal should be connected to the RS-232 connector P5. The RS-232 connector is a 9 pin, female, D-type connector as shown in FIGURE 4-3.

FIGURE 2-6 RS-232 Serial Port Connector

CD	1	6	DSR
TX	2	7	RTS
RX	3	8	CTS
DTR	4	9	N.C.
GND	5		

NOTE: The RTS line (pin 7) is not connected in the M68360QUADS.

Freescale Semiconductor, Inc.

CHAPTER 3 - OPERATING INSTRUCTIONS

3.1 INTRODUCTION

This chapter provides necessary information to use the M68360QUADS in host-controlled and stand-alone configurations. This includes controls and indicators, memory map details, and software initialization of the board.

3.2 CONTROLS AND INDICATORS

The M68360QUADS has the following switches and indicators.

3.2.1 HARD RESET Switch SW1

The HARD RESET switch SW1 resets all QUADS devices, and performs hard reset to the QUICC devices. The switch signal is debounced, and it is not possible to disable it by software.

This switch must be pressed along with the SOFT RESET switch to activate the hard reset mechanism. No action is taken if this switch is pressed alone. This feature is intended to protect the QUICC devices from accidental hard reset.

3.2.2 SOFT RESET Switch SW2

The SOFT RESET switch SW2 resets all QUADS devices, and performs soft reset to the QUICC devices. The switch signal is debounced, and it is not possible to disable it by software.

3.2.3 ABORT Switch SW3

The ABORT switch is normally used to abort program execution and return control to the CPU32bug. The slave QUICC provides the ABORT switch interface and it should be programmed as described in section 3.4. The ABORT switch signal is debounced, and if it is enabled by software, it causes a level 7 interrupt to the master QUICC.

3.2.4 HALT Indicator LD1

The red LED HALT indicator LD1 is lit whenever the master QUICC HALT~ pin is low (asserted).

3.2.5 RUN Indicator LD2

The green LED RUN indicator is connected to the address strobe (AS~) signal. It is lit if the AS~ signal is low (asserted) and it indicates the activity on the bus.

3.2.6 Ethernet TX Indicator LD3

The green LED Ethernet Transmit indicator LD3 blinks whenever the EEST is transmitting data through one of the Ethernet ports P7 or P8.

3.2.7 Ethernet RX Indicator LD4

The green LED Ethernet Receive indicator LD4 blinks whenever the EEST is receiving data from one of the Ethernet ports P7 or P8.

3.2.8 Ethernet CLSN Indicator LD5

The red LED Ethernet Collision indicator LD5 blinks whenever a collision is detected in the AUI P7 port or the TP P8 port, or a jabber condition is detected in TP mode.

3.2.9 Ethernet TPLIL Indicator LD6

The yellow LED Ethernet Twisted Pair Link Integrity indicator LD6 lights to indicate good link integrity on the TP P8 port. The LED is off when the link integrity fails, or when the AUI port is selected.

3.2.10 Ethernet TPPLR Indicator LD7

The red LED Ethernet TP Polarity indicator LD7 lights if the wires connected to the receiver input of TP P8 port are reversed. The LED is lit by the EEST, and remains on when the EEST has automatically corrected for the reversed wires.

3.2.11 Ethernet TPJABB Indicator LD8

The red LED Ethernet TP Jabber indicator LD8 lights whenever a jabber condition is detected on the TP P8 port.

3.3 MEMORY MAP

At the beginning of each cycle, the chip-select generators of the master QUICC and the slave QUICC determine what kind of memory cycle takes place and which device is selected. Cycle types and address spaces are determined by the function code lines FC3-FC0. The cycle types and the devices that respond are described in Table 3-1.

Table 3-1 Cycle Types and Responding Devices

FC3-FC0	Address Space	Responding Devices
0000	Reserved	None
0001	User Data	All
0010	User Program	All
0011	Reserved	None
0100	Reserved	None
0101	Supervisor Data	All
0110	Supervisor Program	All
0111	Supervisor CPU	MBAR registers in both QUICC devices and slave QUICC during interrupt acknowledge cycle.
1XXX	DMA	All

3.3.1 Main Memory Map

The memory map of devices that respond in User Data, User Program, Supervisory Data, Supervisory Program, and DMA spaces is shown in Table 3-2.

Table 3-2 M68360QUADS Main Memory Map

ADDRESS RANGE	Accessed Device	Data Size	NOTES
00000000 - 0001FFFF	Boot EPROM	8	
00020000 - 00021FFF	Master QUICC Internal Memory	32	1
00022000 - 00023FFF	Slave QUICC Internal Memory	32	1
00024000 - 00024001 00024002 - 00025FFF	M68360QUADS Status Register The Status Register appears repeatedly here.	16	2
00026000 - 00026000 00026001 - 00027FFF	Clear NMI Status Registers This function is repeated here	8	2
00028000 - 00028000 00028001 - 00029FFF	Enable A(31:28) This function is repeated here	8	2
00080000 - 000FFFFFFF	Flash Memory	32	
00400000 - 004FFFFFFF 00400000 - 005FFFFFFF 00400000 - 007FFFFFFF 00400000 - 00BFFFFFFF	DRAM SIMM MCM36256 DRAM SIMM MCM36512 DRAM SIMM MCM36100 DRAM SIMM MCM36200	32 + Parity	3
F0000000 - FFFFFFFF	Slave QUICC during interrupt acknowledge cycle	32	4, 5

NOTES:

1. Refer to the MC68360 QUICC User's Manual for complete description of the QUICC internal memory.
2. The device appears repeatedly in multiples of its size. For example, the Status Register appears at memory locations 00024000, 00024002, 00024004 etc...
3. The DRAM SIMM installed in the M68360QUADS is MCM36256 256Kx36 bit. The user may replace the DRAM module with higher density SIMM, and increase the DRAM space up to 8 MByte.
4. The master QUICC can not read the interrupt vector generated by the slave QUICC if it is configured to work in 16 bit mode. The auto-vector function must be used in this mode.
5. External interrupting devices connected to the QUADS must use the auto-vector function, because the interrupt acknowledge address space is occupied by the slave QUICC.

3.3.2 CPU Address Space

The master QUICC can generate four types of CPU space cycles: Breakpoint Acknowledge, LPSTOP broadcast, MBAR access, and Interrupt Acknowledge (IACK). The Breakpoint Acknowledge cycle is not supported in the M68360QUADS. The LPSTOP broadcast cycle can be generated because it does not need a response from an external device. The slave and master QUICCs respond when their MBAR are accessed. The IACK cycle is supported in the M68360QUADS by the slave QUICC, which functions as the interrupt handler on the board and it responds to the IACK cycle.

3.4 Programming the master QUICC

The master QUICC internal registers must be programmed after hardware reset as described in the following paragraphs. The addresses and programming values are in hexadecimal base.

Please refer to the MC68360 QUICC User's Manual for more information.

3.4.1 Module Base Address Register

The master QUICC's module base address register (MBAR) controls the location of its internal memory and registers and their access space. The master QUICC MBAR resides at a fixed location in '0003FF00' in the CPU space. The MBAR must be initialized to '00020001' to obtain the memory map as described in Table 3-2.

3.4.2 Module Configuration Register

The MCR controls the SIM60 configuration in the master QUICC. The BSTM bit in the MCR must be set to '0'. This setting will enable using asynchronous timing on the bus signals.

3.4.3 Auto Vector Register

The auto vector register (AVR) contains 8 bits that correspond to external interrupt levels that require an auto vector response. The AVR must be initialized to 84 to generate auto vectors for interrupt levels 7 and 2. These interrupts are generated through the slave QUICC without supplying interrupt vectors during an IACK cycle.

3.4.4 Reset Status Register

The reset status register (RSR) indicates the source of the last reset that occurred, when the relevant bit is set. This register must be cleared after every reset, so that when the next reset occurs, its source can be easily determined. The register is cleared by writing 'FF'.

3.4.5 CLKO Control Register

The CLKO control register (CLKOCR) controls the operation of the CLKO(0:1) pins. This register must be initialized to 'AB', so that the CLKO1 pin is disabled and the CLKO2 pin is enabled with 1/3 strength output buffer.

3.4.6 PLL Control Register

The PLL control register (PLLCR) controls the operation of the PLL. There is no need to program the PLLCR after hard reset, because the configuration of the MODCK(0:1) pins on the QUADS determines its value. It is recommended to set the PLLWR bit to prevent accidental writing.

3.4.7 Port E Pin Assignment Register

Port E pins can be programmed by the port E pin assignment register (PEPAR). The A(31:28) pins of the master QUICC can be programmed as address lines or as write enable W(0:3)~ lines. Bit 7 in the PEPAR must be cleared to select address lines function, and it must be set to select the write enable function. Until this bit is written, the A(31:28) pins are three-stated.

3.4.8 System Protection Control

The system protection register (SYPCR) controls the system monitors, the software watchdog, and the bus monitor timing. This register must be initialized to '37' to disable the software watchdog, and to enable the bus monitor function.

3.4.9 Global Memory Register

The global memory register (GMR) contains selections for the memory controller of the master QUICC. The SYNC bit must be set and the EMWS bit must be cleared, to obtain synchronous operation of the memory controller when the DMA in the slave QUICC is active.

3.4.10 Base Register 0 and Option Register 0

Base register 0 (BR0) and Option register 0 (OR0) control the operation of CS0~ pin of the master QUICC. The Boot EPROM in the M68360QUADS is connected to this pin. BR0 must be initialized to '00000003', and OR0 must be initialized to '5FFE0004' to obtain the memory map as described in Table 3-2.

3.5 Programming the slave QUICC

The slave QUICC (core disabled) provides the following functions on the M68360QUADS:

1. DRAM Controller
2. Chip Select and DSACK~ generator.
3. Parallel port (ADI).
4. UART for terminal or host computer connection.
5. AppleTalk controller for Macintosh computer connection.
6. BDM controller to other QUICC devices.
7. Ethernet controller.
8. Serial EEPROM interface.
9. General Purpose I/O signals.

The slave QUICC internal registers must be programmed after hardware reset as described in the following paragraphs. The addresses and programming values are in hexadecimal base.

Please refer to the MC68360 QUICC User's Manual for more information.

3.5.1 Module Base Address Register

The slave QUICC's module base address register (MBAR) controls the location of its internal memory and registers and their access space. The slave QUICC MBAR resides at a fixed location in '0003FF04' in the CPU space. Before accessing the MBAR, the software must write to the module base address register enable (MBARE), which resides at fixed location in '0003FF08' in the CPU space.

The MBARE~ pin of the slave QUICC is connected to data line D30, therefore the MBARE register must be initialized to 'BFFFFFFF' before initializing the MBAR.

The MBAR must be initialized to '00022001' to obtain the memory map as described in Table 3-2.

Note: If the master QUICC data bus is configured to operate in 16 bit mode, the MBARE must be written with 'BFFF' before each word access to the MBAR.

3.5.2 Module Configuration Register

The module configuration register (MCR) controls the SIM60 configuration in the slave QUICC. The BSTM bit in the MCR must be set to '0'. This setting will enable using asynchronous timing on the bus signals.

3.5.3 CLKO Control Register

The CLKO control register (CLKOCR) controls the operation of the CLKO(0:1) pins. This register must be initialized to 'AF', so that the CLKO(0:1) pins of the slave QUICC are disabled.

3.5.4 PLL Control Register

The PLL control register (PLLCR) controls the operation of the PLL. There is no need to program the PLLCR after hard reset, because the configuration of the MODCK(0:1) pins on the QUADS determines its value. It is recommended to set the PLLWR bit to prevent accidental writing.

3.5.5 Port E Pin Assignment Register

Port E pins can be programmed by the port E pin assignment register (PEPAR). The PEPAR must be initialized to '3760' to configure Port E of the slave QUICC as follows:

- The output of the slave QUICC interrupt request is on IOOUT(0:2)~ pins.
- RAS1~ and RAS2~ double drive function is used to drive the DRAM.
- The A(31:28) pins of the slave QUICC are configured as address lines.
- The OE~/AMUX pin is configured as AMUX to drive the external multiplexers of the DRAM.
- The CAS(0:3)~ output function is used for the DRAM.
- CS7~ output function is enabled.

3.5.6 System Protection Control

The system protection register (SYPCR) controls the system monitors, the software watchdog, and the bus monitor timing. This register must be initialized to '37' to disable the software watchdog and to enable the bus monitor function in the slave QUICC.

3.5.7 Global Memory Register

The global memory register (GMR) contains selections for the memory controller of the slave QUICC. The GMR must be initialized according to the size and the access time of the DRAM SIMM installed on the M68360QUADS as follows:

- For 70 nsec DRAM type MCM36256 or MCM36100, the GMR must be initialized to '17840380'.
- For 70 nsec DRAM type MCM36512 or MCM36200, the GMR must be initialized to '0A840380'.
- For 80 nsec DRAM type MCM36256 or MCM36100, the GMR must be initialized to '17A40380'.
- For 80 nsec DRAM type MCM36512 or MCM36200, the GMR must be initialized to '0AA40380'.
- For 100 nsec DRAM type MCM36256 or MCM36100, the GMR must be initialized to '17A44380'.
- For 100 nsec DRAM type MCM36512 or MCM36200, the GMR must be initialized to '0AA44380'.

The GMR defines the following parameters:

- The DRAM refresh period is 15.36 μ sec.
- The DRAM refresh cycle length depends on the DRAM access time, and it is either 3 clocks or 4 clocks long.
- The DRAM module port size is 32 bits.
- The parity is disabled.
- The CS~/RAS~ lines of the slave QUICC will not assert when accessing the CPU space.
- Internal address multiplexing for the DRAM is disabled.

3.5.8 Base Register 0 and Option Register 0

Base register 0 (BR0) and Option register 0 (OR0) control the operation of CS0~ pin of the slave QUICC. This pin has no connection on the M68360QUADS, but CS0~ and CS7~ are used to distinguish between accesses to the board internal resources and external devices that may be attached to the board. BR0 must be initialized to '00000003', and OR0 must be initialized to 'FFFE0006', for proper operation of the board.

3.5.9 Base Register 1 and Option Register 1

Base register 1 (BR1) and Option register 1 (OR1) control the operation of RAS1~ pin of the slave QUICC. This pin is connected to the DRAM module. These registers must be initialized according to the type of the DRAM SIMM installed on the M68360QUADS as follows:

- OR1 must be initialized to '2FF00009' for 70 nsec or 80 nsec DRAM, types MCM36256 or MCM36512.
- OR1 must be initialized to '3FF00009' for 100 nsec DRAM, types MCM36256 or MCM36512.
- OR1 must be initialized to '2FC00009' for 70 nsec or 80 nsec DRAM, type MCM36100 or MCM36200.
- OR1 must be initialized to '3FC00009' for 100 nsec DRAM, type MCM36100 or MCM36200.

BR1 must be initialized to '00400005', disregarding the type and the access time of the DRAM.

Note: The CPU32bug software does not access BR1 and OR1 after reset if the Enable DRAM switch in U52 is in 'OFF' position.

The software must perform 8 accesses to the RAS1~ address space after initialization for proper operation of the DRAM.

3.5.10 Base Register 2 and Option Register 2

Base register 2 (BR2) and Option register 2 (OR2) control the operation of RAS2~ pin of the slave QUICC. This pin is connected to the DRAM module. These registers must be initialized if the type of the DRAM SIMM installed on the M68360QUADS is MCM36512 or MCM36200, because these two types contain two DRAM banks, and RAS1~ can not be connected to both banks.

If the DRAM SIMM type is MCM36512, BR2 must be initialized to '00500005'. OR2 must be initialized to '2FF00009' for 70 nsec or 80 nsec DRAM, and to '3FF00009' for 100 nsec DRAM.

If the DRAM SIMM type is MCM36200, BR2 must be initialized to '00800005'. OR2 must be initialized to '2FC00009' for 70 nsec or 80 nsec DRAM, and to '3FC00009' for 100 nsec DRAM.

Note: The CPU32bug software does not access BR2 and OR2 after reset if the Enable DRAM switch in U52 is in 'OFF' position.

The software must perform 8 accesses to the RAS2~ address space after initialization for proper operation of the DRAM.

3.5.11 Base Register 3 and Option Register 3

Base register 3 (BR3) and Option register 3 (OR3) control the operation of CS3~ pin of the slave QUICC. The Flash Memory on the M68360QUADS is connected to this pin. BR3 must be initialized to '00080009', and OR3 must be initialized to '3FF80000' to obtain the memory map as described in Table 3-2.

Note: The CPU32bug software does not access BR3 and OR3 after reset if the Enable Flash Memory switch in U52 is in 'OFF' position.

3.5.12 Base Register 4 and Option Register 4

Base register 4 (BR4) and Option register 4 (OR4) control the operation of CS4~ pin of the slave QUICC. The M68360QUADS Status Register is connected to this pin. BR4 must be initialized to '00024003', and OR4 must be initialized to '0FFFE002' to obtain the memory map as described in Table 3-2.

3.5.13 Base Register 5 and Option Register 5

Base register 5 (BR5) and Option register 5 (OR5) control the operation of CS5~ pin of the slave QUICC. The M68360QUADS has Abort Register that is set by the Abort switch and Host NMI Register that is set by the host computer connected to the ADI port. Setting either register generates a level 7 interrupt to the master QUICC. The CS5~ signal is used on the M68360QUADS by the interrupt handling routine to clear these registers. BR5 must be initialized to '00026001', and OR5 must be initialized to '0FFFE004' to obtain the memory map as described in Table 3-2.

3.5.14 Base Register 6 and Option Register 6

Base register 6 (BR6) and Option register 6 (OR6) control the operation of CS6~ pin of the slave QUICC. The A(31:28) pins of the master QUICC can be configured as address lines or as write enable lines. After hard reset, these lines are in three-state condition until the PEPAR of the master QUICC is written. If the A(31:28) Configuration switch in U52 is 'ON', the CPU32bug software initializes the PEPAR in the master QUICC, and asserts the CS6~ signal to enable using the A(31:28) as address lines on the board. BR6 must be initialized to '00028001', and OR6 must be initialized to '0FFFE004' to obtain the memory map as described in Table 3-2.

Note: If the A(31:28) pins are used as write enable lines, CS6~ must never be asserted. It is recommended to initialize BR6 to '00028000' to avoid accidental accesses to the address space of CS6~.

3.5.15 Base Register 7 and Option Register 7

Base register 7 (BR7) and Option register 7 (OR7) control the operation of CS7~ pin of the slave QUICC. CS0~ and CS7~ are used to distinguish between accesses to the board internal resources and external devices that may be attached to the board. For proper operation of the board, BR7 must be initialized to '00000001', and OR7 must be initialized to 'F0000006'.

3.5.16 Port A Open Drain Register

Port A of the slave QUICC is 16 pins port, and each pin may be configured as general purpose I/O pin or as dedicated peripheral interface pin. The port A open drain register (PAODR) configures the drivers of port A pins as open-drain or as active drivers. The PAODR must be initialized to '0000' to select the active drivers configuration.

3.5.17 Port A Data Register

Port A data register (PADAT) can be read to check the data at the pin. If a port pin is configured as general purpose output pin, the value in the PADAT for that pin is driven onto the pin. It is recommended to initialize PADAT to 'FFFF' before configuring the other port registers.

3.5.18 Port A Data Direction Register

The port A data direction register (PADIR) has different functions according to the configuration of the port pins. If a pin is general purpose I/O pin, the value in the PADIR for that pin defines the direction of the pin. If a pin is dedicated peripheral interface pin, the value in the PADIR for that pin may select one of two dedicated functions of the pin. The PADIR must be initialized to '3C00'.

3.5.19 Port A Pin Assignment Register

The port A pin assignment register (PAPAR) configures the function of the port pins. If the value in the PAPAR for a pin is '0' the pin is general purpose I/O, otherwise the pin is dedicated peripheral interface pin. The PAPAR must be initialized to '033F'.

3.5.20 Port B Open Drain Register

Port B of the slave QUICC is 18 pins port, and each pin may be configured as general purpose I/O pin or as dedicated peripheral interface pin. The port B open drain register (PBODR) configures the drivers of port B pins as open-drain or as active drivers. The PBODR must be initialized to '0000' to select the active drivers configuration.

3.5.21 Port B Data Register

Port B data register (PBDAT) can be read to check the data at the pin. If a port pin is configured as general purpose output pin, the value in the PBDAT for that pin is driven onto the pin. It is recommended to initialize PBDAT to '3FFFF' before configuring the other port registers.

3.5.22 Port B Data Direction Register

The port B data direction register (PBDIR) has different functions according to the configuration of the port pins. If a pin is general purpose I/O pin, the value in the PBDIR for that pin defines the direction of the pin. If a pin is dedicated peripheral interface pin, the value in the PBDIR for that pin may select one of two dedicated functions of the pin. The PBDIR must be initialized to '0007F'. Pins 10 to 17 are connected to the ADI port data bus, therefore their direction must be changed by software according to the data flow.

3.5.23 Port B Pin Assignment Register

The port B pin assignment register (PBPAR) configures the function of the port pins. If the value in the PBPAR for a pin is '0' the pin is general purpose I/O, otherwise the pin is dedicated peripheral interface pin. The PBPAR must be initialized to '0000E'.

3.5.24 Port C Data Register

Port C of the slave QUICC is 12 pin port, and each pin may be configured as general purpose I/O pin or as dedicated peripheral interface pin, with interrupt capability. Port C data register (PCDAT) can be read to check the data at the pin. If a port pin is configured as general purpose output pin, the value in the PCDAT for that pin is driven onto the pin. It is recommended to initialize PCDAT to '0740' before configuring the other port registers.

3.5.25 Port C Data Direction Register

The port C data direction register (PCDIR) has different functions according to the configuration of the port pins. If a pin is general purpose I/O pin, the value in the PCDIR for that pin defines the direction of the pin. If a pin is dedicated peripheral interface pin, the value in the PCDIR for that pin may select one of three dedicated functions of the pin. The PCDIR must be initialized to '0F8C'.

3.5.26 Port C Pin Assignment Register

The port C pin assignment register (PCPAR) configures the function of the port pins, along with PCDIR and PCSO. The PCPAR must be initialized to '0003'.

3.5.27 Port C Special Options Register

The port C special options register (PCSO) configures the CDx and CTSx pins. Port C can detect changes on the CTS and CD lines, and assert the corresponding interrupt while the SCC simultaneously uses those lines. The PCSO must be initialized to '0030'.

CHAPTER 4 - FUNCTIONAL DESCRIPTION

4.1 INTRODUCTION

This chapter details the hardware design of the M68360QUADS, and describes each module.

4.2 Master QUICC

The CPU of the master QUICC device, U8 in sheet 4, is the main processor on the QUADS. The working frequency of the QUICC is 25 Mhz, but the user can change the frequency by replacing the oscillator U27 in sheet 5. The frequency of the oscillator is twice the working frequency of the board.

The master QUICC can be configured to operate either in 32 bit mode or 16 bit mode, according to the level of MPRTY3 signal during hard reset. The user can drive this signal low (16 bit mode) either by selecting this mode in Dip-Switch U52 (Sheet 14), or by driving it through the expansion connector P2 (Sheet 21).

In 16 bit mode, the data transceivers (Sheet 6) and the data bus controller (Sheet 8) control the data flow between the 16 bit data bus of the master QUICC and the 32 bit devices on the QUADS, by directing the data to the proper lines. There is one restriction on the software so that it can support both operating modes, provided that it uses the auto-vector function of the master QUICC. If the slave QUICC interrupts the master QUICC, the master can read the interrupt vector only in 32 bit mode. When programming the MBAR register in the slave QUICC, it must access it in two 16 bit transfers, and it must write to the MBARE register before each access. This restriction is due to the design of the QUICC, which requires writing to the MBARE register before accessing the MBAR register, therefore when the QUICC operates in 16 bit mode, it can not access the MBAR in 32 bit transfers.

All the pins of the master QUICC device are available unbuffered to the user through the expansion connectors P1 and P2 (Sheets 20 and 21), and the logic analyzer connectors PD1 to PD6 (Sheets 18 and 19). The user can monitor the QUICC activity and connect the QUADS to his own hardware application during its development stage. The logic analyzer connectors PD1 to PD5 can be connected directly to HP logic analyzers.

The master QUICC pins are buffered from all the devices on the QUADS, to minimize their load and to enable easy connection to the user hardware application.

The BDM pins of the master QUICC are also available for the user through connector P3 (Sheet 16). This connector can be used to download code and to monitor functions.

4.3 Boot EPROM

The boot EPROM is the 27C010 device U48 in sheet 2 (200 nsec access time, 128K x 8 bit) and is used to store the debug and the boot programs. The EPROM is accessed as 8 bit device, using the Global CS port of the master QUICC.

It is possible for the user to disable accesses to the EPROM on the QUADS, and to use the Global CS port to access his own EPROM on his application board after reset. This is done by setting the Enable EPROM switch in U52 to 'OFF', thus disconnecting the M_CS0~ signal from E_CS~ signal.

FIGURE 4-1 HARDWARE BLOCK DIAGRAM

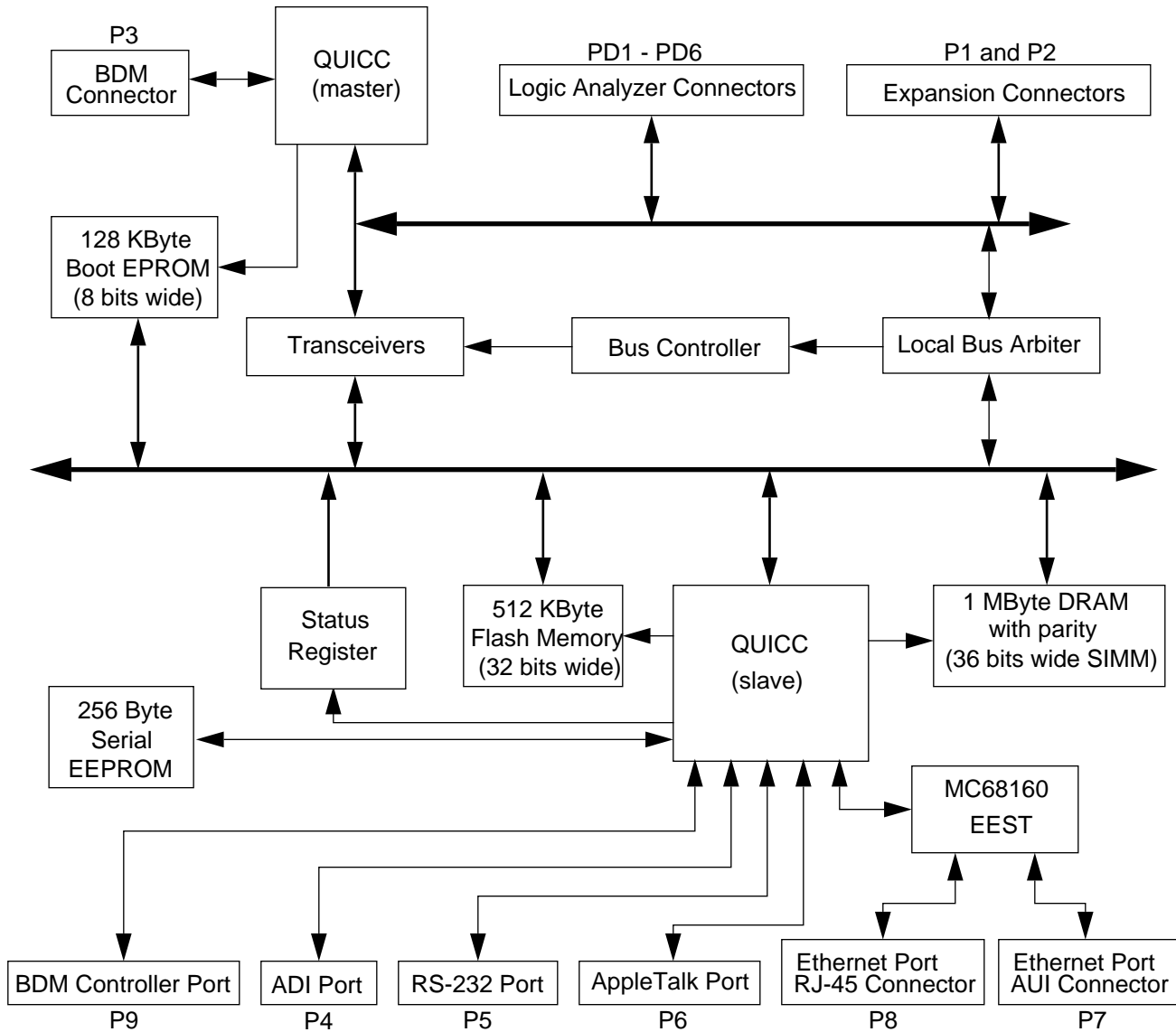

Freescale Semiconductor, Inc.

4.4 Flash Memory

Four Flash Memory devices, the 28F010 (128 KByte, 120 nsec access time) are used to form 512 Kbyte program storage memory. The devices, U72 to U75 in sheet 2, are organized as long-word (32 bits wide). The Flash Memory devices are soldered to the board, and program code updates will be done on board without the need for external EPROM programmer. The programming software is stored in the boot EPROM, which loads the new code through one of the QUADS ports, erases the Flash Memory, and programs the new code.

The slave QUICC device provides the F_CS~ signal to the Flash Memory. The user must connect external 12v power supply to connector P12 to program the devices.

The user may indicate to the CPU32bug software not to initialize BR3 and OR3 registers in the slave QUICC by setting the Enable Flash Memory switch in U52 to OFF. This setting is used to disable accesses to the Flash Memory after hard reset, and its address space may be used by the user.

4.5 EEPROM

The EEPROM used in the QUADS is Motorola MCM2814 256 byte serial EEPROM (U33 in sheet 2). The slave QUICC SPI port (port B pins 0 to 3) is used to control accesses to the EEPROM.

The MCM2814 has internal hardware protection against inadvertent writes to the EEPROM that might happen at power up or power down time.

4.6 DRAM

The QUADS is supplied with 1 Mbyte of Dynamic RAM, which is implemented by the MCM36256S80 DRAM module. The module, U71 in sheet 1, is a 72 lead SIMM, 80 nsec access time, organized as 256K x 36 bit for data and parity signals.

It is possible to replace the supplied DRAM SIMM with a higher density module, in order to increase the DRAM memory space up to 8 Mbyte. The higher density modules, such as the MCM36200, may require using RAS1 and RAS2 signals of the slave QUICC, because they are organized as two memory banks. These signals are supplied to the DRAM socket in the QUADS, so that the user does not need to do any wiring.

The SIMM has four presence detect signals, SIMM1 to SIMM4, which can be read by the software through the Status Register (U61 and U39 in sheet 14). The CPU32bug software determines the DRAM memory space and access time according to these signals, as described in Table 4-1.

Table 4-1 DRAM SIMM Types

SIMM(4:1)	SIMM Type	SIMM Organization	Access Time (nsec)	Control Signals
0000	MCM36100S10	1M x 36	100	RAS1
0001	MCM36512S10	512K x 36	100	RAS1, RAS2
0010	MCM36256S10	256K x 36	100	RAS1
0011	MCM36200S10	2M x 36	100	RAS1, RAS2
0100	MCM36100S80	1M x 36	80	RAS1
0101	MCM36512S80	512K x 36	80	RAS1, RAS2
0110	MCM36256S80	256K x 36	80	RAS1
0111	MCM36200S80	2M x 36	80	RAS1, RAS2
1000	MCM36100S70	1M x 36	70	RAS1
1001	MCM36512S70	512K x 36	70	RAS1, RAS2
1010	MCM36256S70	256K x 36	70	RAS1
1011	MCM36200S70	2M x 36	70	RAS1, RAS2
1100	Not Valid			
1101	Not Valid			
1110	Not Valid			
1111	Not Valid			

The DRAM is controlled by the slave QUICC device, using its DRAM Controller function for normal accesses, page mode accesses, and refresh accesses. The DRAM can be accessed by the master QUICC, the slave QUICC (the IDMA and the SDMA are not disabled), and external bus master connected to the expansion connectors of the QUADS.

The user may indicate to the CPU32bug software not to initialize BR1, OR1, BR2, and OR2 registers in the slave QUICC by setting the Enable DRAM switch in U52 to OFF. This setting is used to disable accesses to the DRAM after hard reset, and its address space may be used by the user.

Note: The CPU32bug software requires 8 KByte of RAM space located at address 00400000. If the DRAM is disabled, the user must connect external RAM to the QUADS for the software to run properly.

4.7 Slave QUICC

During normal operation, the CPU of the slave QUICC (U4 in sheet 3) is disabled, and the device is used to implement the following functions on the QUADS:

1. DRAM Controller
2. Chip Select and DSACK~ generator.
3. Parallel port (ADI).
4. UART for terminal or host computer connection.
5. AppleTalk controller for MacIntosh computer connection.
6. BDM controller to other QUICC devices.
7. Ethernet controller.
8. Serial EEPROM interface.
9. General Purpose I/O signals.

The address of the MBAR register is configured to be at \$0033FF04. The master QUICC must write the MBARE register at address \$0033FF08 before each access to the slave MBAR register.

The slave QUICC is essential to make the master QUICC pins available for the user implementations. The QUICC peripherals (such as the IDMA and SDMA) can request the bus and become bus master, while the CPU is disabled.

4.7.1 DRAM Controller

The slave QUICC device provides the necessary control signals for the DRAM module. The software on the QUADS reads the presence detect pins of the SIMM, and sets the DRAM Controller parameters according to the DRAM module, and the access time of the DRAM.

The hardware connection of the slave QUICC to the DRAM module is straight forward. External address multiplexers (U67, U62, and U53 in sheet 1) are used to drive the DRAM address lines, to enable external bus masters to access the DRAM. The CPU32bug software programs the PEPAR so that the OE~/AMUX pin of the slave QUICC is configured as AMUX to drive the address multiplexers.

The RAS1~ and RAS2~ pins of the slave QUICC drive the DRAM SIMM. The double-drive signals RAS1DD~ and RAS2DD~ also drive the DRAM to decrease signal load.

4.7.2 Chip Select and DSACK~ generator

The slave QUICC device provides the Chip Select signals to the QUADS devices as follows:

1. CS0~ pin of the slave QUICC is not connected to any device on the QUADS, but its function is used along with CS7~ by the bus control logic to distinguish between accesses to the board devices and external devices that may be attached to the board.
2. CS1~ and CS2~ are connected to the DRAM SIMM, and they act as RAS1~ and RAS2~.
3. CS3~ is connected to the Flash Memory (U72, U73, U74, and U75 in sheet 2).

4. CS4~ is connected to the M68360QUADS Status Register (U61 and U39 in sheet 14).
5. CS5~ is connected to the Abort and Host NMI registers, U68 in sheet 7 and U31 in sheet 12. This signal is used to clear these registers after interrupt level 7.
6. CS6~ is connected to the Enable Address register, U22 in sheet 5. This signal is used to enable using A(31:28) lines of the master QUICC as address lines on the QUADS.
7. CS7~ is connected to the Bus Controller, U51 in sheet 8. If this signal is negated, it indicates that the current access is to a device on the QUADS. The DSACK~ generator is disabled for this signal.

4.7.3 ADI Port (Sheet 12)

The ADI parallel port supplies parallel link from the QUADS to various host computers. This port is connected via a 37 line cable to a special board called ADI (Application Development Interface) installed in the host computer. It is possible to connect the QUADS board to an IBM-PC/XT/AT or to SUN-4 SPARC station, provided that they have an ADI board with the appropriate software drivers installed on them.

Each QUADS can have 8 possible slave addresses set for its ADI port, enabling up to 8 QUADS boards to be connected to the same ADI board. The QUADS address is selected by U46 in sheet 9.

The ADI port connector P4 is a 37 pin, male, D type connector. The connection between the QUADS and the host computer is by a 37 line flat cable, supplied with the ADI board. FIGURE 4-2 below shows the pin configuration of the connector.

FIGURE 4-2 ADI Port Connector

Gnd	20	1	INT_ACK
Gnd	21	2	N.C.
Gnd	22	3	HST_ACK
Gnd	23	4	ADS_ALL
Gnd	24	5	ADS_RESET
Gnd	25	6	ADS_SEL2
(+ 12 v) N.C.	26	7	ADS_SEL1
HOST_VCC	27	8	ADS_SEL0
HOST_VCC	28	9	HOST_REQ
HOST_VCC	29	10	ADS_REQ
HOST_ENABLE~	30	11	ADS_ACK
Gnd	31	12	ADS_INT
Gnd	32	13	HOST_BRK~
Gnd	33	14	ADS_BRK
PD0	34	15	N.C.
PD2	35	16	PD1
PD4	36	17	PD3
PD6	37	18	PD5
		19	PD7

NOTE: Pin 26 on the ADI is connected to +12 v power supply, but it is not used in the QUADS.

4.7.3.1 ADI Port Signal Description

The ADI port on the M68360QUADS was slightly modified to generate either hard reset or soft reset. This feature was added to comply with the QUICC reset mechanism. The host software written for the M68360QUADS should be able to work properly with existing QUADS boards, such as the M68302ADS.

In the list below, the directions 'I', 'O', and 'I/O' are relative to the QUADS board. (I.E. 'I' means input to the QUADS)

- ADS_SEL(0:2) - 'I'
These three input lines determine the slave address of the QUADS being accessed by the host computer. Up to 8 boards can be addressed by one ADI board.
- ADS_ALL - 'I'
This input line is used to reset or abort program execution on all QUADS development boards that are connected to the same ADI board.
- HOST_ENABLE~ - 'I'
This line is always driven low by the ADI board. The QUADS software uses this line to determine if a host is connected to the ADI port.
- ADS_BRK - 'I'
When a host is connected, this line is used in conjunction with the addressing lines or with the ADS_ALL line to generate a non-maskable interrupt (interrupt level 7) to the QUICC.
- ADS_RESET - 'I'
When a host is connected, this line is used in conjunction with the addressing lines or with the ADS_ALL line to reset the QUADS board. The type of the reset, hard or soft, is determined by INT_ACK signal.
- HOST_REQ - 'I'
This signal initiates a host to QUADS write cycle.
- ADS_ACK - 'O'
This signal is the QUADS response to the HOST_REQ signal, indicating that the QUADS board has detected the assertion of HOST_REQ.
- ADS_REQ - 'O'
This signal initiates an QUADS to host write cycle.
- HST_ACK - 'I'
This signal serves as the host's response to the ADS_REQ signal.
- HOST_BRK~ - 'O'
This open-collector signal generates an interrupt to the host. This signal is common to all QUADS boards that are connected to the same ADI.
- ADS_INT - 'O'
This line is polled by the host computer during its interrupt acknowledge cycle to determine which QUADS board has generated the interrupt.
- INT_ACK - 'I'
This line is asserted by the host at the end of its interrupt acknowledge cycle. This signal is used by the QUADS hardware to negate the HOST_BRK~ signal. The software in the QUADS must negate the ADS_INT signal upon detecting the assertion of INT_ACK to support the daisy-chain interrupt structure.

This line is also used by the host to generate either hard reset or soft reset. In this case, this line is used in conjunction with ADS_RESET, and with either the addressing lines or with the ADS_ALL line.

- HOST_VCC - 'I' (three lines)
These lines are power lines from the host computer. In the QUADS, these lines are used by the software to determine if the host computer is powered on. The QUADS does not use these lines for power supply.
- PD(0:7) - 'I/O'
These eight I/O lines are the parallel data bus. This bus is used to transmit and receive data from the host computer.

4.7.4 RS-232 Serial Port (Sheet 11)

The serial port is provided by the slave QUICC SCC3 serial channel. The M68360QUADS can be connected to a VT100 compatible terminal or to a host computer through the serial port.

The RS-232 serial port connector P5 is a 9 pin, female, D-type connector as shown in FIGURE 4-3.

FIGURE 4-3 RS-232 Serial Port Connector

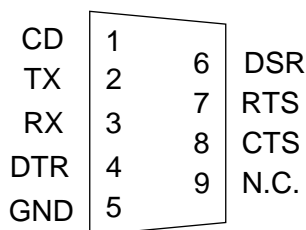

4.7.4.1 RS-232 Port Signal Description

In the list below, the directions 'I', 'O', and 'I/O' are relative to the QUADS board. (I.E. 'I' means input to the QUADS)

- CD (O) - Data Carrier Detect. This line is always asserted by the QUADS.
- TX (O) - Transmit Data.
- RX (I) - Receive Data.
- DTR (I) - Data Terminal Ready. This signal is used by the software in the QUADS to detect if a terminal is connected to the QUADS board.
- DSR (O) - Data Set Ready. This line is always asserted by the QUADS.
- RTS (I) - Request To Send. This line is not connected in the QUADS.
- CTS (O) - Clear To Send. This line is always asserted by the QUADS.

4.7.5 AppleTalk Port (Sheet 11)

The AppleTalk port is provided by the slave QUICC SCC2 serial channel. The AppleTalk is the 230.4 kbps local area network that connects multiple Macintosh computers and printers.

The AppleTalk port connector P6 is 8 pin, MINI DIN JACK connector as shown in FIGURE 4-4.

FIGURE 4-4 AppleTalk Connector

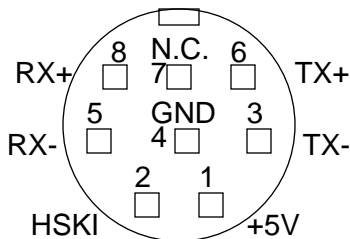

4.7.5.1 AppleTalk Port Signal Description

In the list below, the directions 'I', 'O', and 'I/O' are relative to the QUADS board. (I.E. 'I' means input to the QUADS)

- +5V (O) - 5V output from the QUADS through 100 ohm resistor.
- HSKI (I) - Hand Shake Input.
- TX- (O) - Transmit Data (negative).
- RX- (I) - Receive Data (negative).
- TX+ (O) - Transmit Data (positive).
- RX+ (I) - Receive Data (positive).

4.7.6 BDM Controller (Sheet 16)

The slave QUICC enables the M68360QUADS to become BDM controller to control other QUICC devices on the user application. The BDM feature enables the user to download code and provides hardware and software debugging capability of the user application.

The 8 pin BDM connector P9 utilizes five pins of the slave QUICC port B. These pins are configured as general purpose I/O pins.

4.7.7 Ethernet Controller (Sheet 10)

The slave QUICC provides Ethernet port for the M68360QUADS by connecting SCC1 to Motorola MC68160 EEST device (U35 in sheet 10). The MC68160 provides two Ethernet interfaces, twisted-pair on P8 and AUI on P7. The LEDs LD3-LD8 are controlled by the EEST, and they provide indications about the status of the Ethernet ports activity.

The signals between the slave QUICC and the MC68160 appear on connector P10 for debugging purposes. P10 is a set of wire holes.

The socket U24 is installed for internal factory testing only. For proper operation of the EEST, this socket must be empty.

4.7.7.1 Ethernet AUI Port Signal Description

The AUI port connector P7 is a 15 pin, female, D-type connector as shown in FIGURE 4-3.

FIGURE 4-5 Ethernet AUI Port Connector

GND	1	9	ACX-
ACX+	2	10	ATX-
ATX+	3	11	GND
GND	4	12	ARX-
ARX+	5	13	+12V
GND	6	14	GND
N.C.	7	15	N.C.
GND	8		

The list below describes the port signals. The directions 'I', 'O', and 'I/O' are relative to the QUADS board. (I.E. 'I' means input to the QUADS)

- ACX+ (I) - Collision Input (positive).
- ATX+ (O) - Transmit Data (positive).
- ARX+ (I) - Receive Data (positive).
- ACX- (I) - Collision Input (negative).
- ATX- (O) - Transmit Data (negative).
- ARX- (I) - Receive Data (negative).
- +12V (O) - +12V power supply from the QUADS.

4.7.7.2 Ethernet Twisted-Pair Port Signal Description

The twisted-pair port connector P8 is a 8 pin, RJ-45 connector as shown in FIGURE 4-3.

FIGURE 4-6 Ethernet Twisted-Pair Port Connector

TPTX+	1
TPTX-	2
TPRX+	3
N.C.	4
N.C.	5
TPRX-	6
N.C.	7
N.C.	8

The list below describes the port signals. The directions 'I', 'O', and 'I/O' are relative to the QUADS board. (I.E. 'I' means input to the QUADS)

- TPTX+ (O) - Transmit Data (positive).
- TPTX- (O) - Transmit Data (negative).
- TPRX+ (I) - Receive Data (positive).
- TPRX- (I) - Receive Data (negative).

4.7.8 Serial EEPROM Interface (Sheet 2)

The MCM2814 serial EEPROM (U33 in sheet 2) is 256 bytes EEPROM with SPI interface. It is controlled by the SPI port of the slave QUICC (pins 1,2 and 3 of port B), and by a general purpose output pin (pin 0 of port B). The SPI port operates in master mode.

4.7.9 Slave QUICC General Purpose I/O Pins

The slave QUICC has three ports, A, B, and C, whose pins can be individually configured by software to be general purpose I/O pin or dedicated peripheral function. The QUICC also has another port, E, whose pins are not general purpose I/O, but they can be configured to operate in one of two possible modes.

The following subsections describe the slave QUICC ports. Refer to section 3.5 on page 18 for the required programming information.

4.7.9.1 Slave QUICC Port A

Port A is 16 pins port. Table 4-2 describes the configuration of port A.

Table 4-2 Port A Pins Description

Pin	Pin Name	Description
0	Ethernet RX	This pin is connected to the receive data output of the EEST. It is configured as the receive data of SCC1 in the slave QUICC.
1	Ethernet TX	This pin is connected to the transmit data input of the EEST. It is configured as the transmit data of SCC1 in the slave QUICC.
2	AppleTalk RX	This pin is connected to the receive data output of the AppleTalk transceiver U29. It is configured as the receive data of SCC2 in the slave QUICC.
3	AppleTalk TX	This pin is connected to the transmit data input of the AppleTalk transceiver U29. It is configured as the transmit data of SCC2 in the slave QUICC.
4	RS-232 RX	This pin is connected to the receive data output of the RS-232 transceiver U23. It is configured as the receive data of SCC3 in the slave QUICC.
5	RS-232 TX	This pin is connected to the transmit data input of the RS-232 transceiver U23. It is configured as the transmit data of SCC3 in the slave QUICC.
6	Enable DRAM	This pin is connected to switch 3 in dip-switch U52. It is configured as input pin in the slave QUICC, and its level indicates to the CPU32bug software if it should enable accesses to the DRAM on the QUADS. If the level is '0', the DRAM is enabled.
7	Enable Flash	This pin is connected to switch 4 in dip-switch U52. It is configured as input pin in the slave QUICC, and its level indicates to the CPU32bug software if it should enable accesses to the Flash Memory on the QUADS. If it is '0', the Flash is enabled.
8	Ethernet TCLK	This pin is connected to the transmit clock output of the EEST. It is configured as the transmit clock of SCC1 in the slave QUICC.
9	Ethernet RCLK	This pin is connected to the receive clock output of the EEST. It is configured as the receive clock of SCC1 in the slave QUICC.
10	ADS G~	This pin is connected to the ADI port logic. It is configured as output pin in the slave QUICC, and it is used by the ADI logic to control the ADI data transceiver.
11	ADS INT~	This pin is connected to the ADI port signal ADS_INT through the buffer U16. It is configured as output pin in the slave QUICC, and it is also used by the ADI logic to interrupt the host computer.
12	ADS ACK~	This pin is connected to the ADI port signal ADS_ACK through the buffer U16. It is configured as output pin in the slave QUICC.
13	ADS REQ~	This pin is connected to the ADI port signal ADS_REQ through the buffer U16. It is configured as output pin in the slave QUICC.
14	VPP ON	This pin is configured as input pin, and it is used to sense the +12V power supply. If it is '1', +12V is applied to the QUADS.
15	Spare	This pin is connected to switch 4 of dip-switch U46, and it is configured as input pin in the slave QUICC. It has no function on the ADS, and it is reserved for future applications.

4.7.9.2 Slave QUICC Port B

Port B is 18 pins port. Table 4-2 describes the configuration of port B.

Table 4-3 Port B Pins Description

Pin	Pin Name	Description
0	EEPROM Select	This pin is connected to the select input of the EEPROM, and it is configured as output pin in the slave QUICC.
1	EEPROM CLK	This pin is connected to the clock input of the EEPROM, and it is configured as the SPI clock of the slave QUICC.
2	EEPROM Serial In	This pin is connected to the serial data input of the EEPROM, and it is configured as the SPI MOSI of the slave QUICC.
3	EEPROM Serial Out	This pin is connected to the serial data output of the EEPROM, and it is configured as the SPI MISO of the slave QUICC.
4	BDM CLK	This pin is connected to the BDM Controller connector P9. It is configured as output pin in the slave QUICC.
5	BDM Reset	This pin is connected to the BDM Controller connector P9. It is configured as output pin in the slave QUICC.
6	BDM Data Out	This pin is connected to the BDM Controller connector P9. It is configured as output pin in the slave QUICC.
7	BDM Data In	This pin is connected to the BDM Controller connector P9. It is configured as input pin in the slave QUICC.
8		This pin is not connected on the QUADS board.
9	BDM Freeze	This pin is connected to the BDM Controller connector P9. It is configured as input pin in the slave QUICC.
10	ADI Data 0	This pin is connected to the ADI port signal PD0 through the data bus transceiver U2, and it is configured as I/O pin.
11	ADI Data 1	This pin is connected to the ADI port signal PD0 through the data bus transceiver U2, and it is configured as I/O pin.
12	ADI Data 2	This pin is connected to the ADI port signal PD0 through the data bus transceiver U2, and it is configured as I/O pin.
13	ADI Data 3	This pin is connected to the ADI port signal PD0 through the data bus transceiver U2, and it is configured as I/O pin.
14	ADI Data 4	This pin is connected to the ADI port signal PD0 through the data bus transceiver U2, and it is configured as I/O pin.
15	ADI Data 5	This pin is connected to the ADI port signal PD0 through the data bus transceiver U2, and it is configured as I/O pin.
16	ADI Data 6	This pin is connected to the ADI port signal PD0 through the data bus transceiver U2, and it is configured as I/O pin.
17	ADI Data 7	This pin is connected to the ADI port signal PD0 through the data bus transceiver U2, and it is configured as I/O pin.

4.7.9.3 Slave QUICC Port C

Port C is 12 pins port. Table 4-2 describes the configuration of port C.

Table 4-4 Port C Pins Description

Pin	Pin Name	Description
0	TENA	This pin is connected to the TENA input of the EEST. It is configured as the RTS signal of SCC1 in the slave QUICC.
1	AppleTalk Enable	This pin is connected to the enable input of the AppleTalk transceiver U29. It is configured as the RTS signal of SCC2 of the slave QUICC. If this pin is '0', the transceiver output to the AppleTalk port P6 is enabled.
2	EEST CS2	This pin is connected to the CS2 input of the EEST, and it is configured as output pin in the slave QUICC. If this pin is '1', the EEST operates in standby mode, and if it is '0', the EEST is in normal operation mode.
3	TPEN	This pin is connected to the TPEN I/O pin of the EEST, and it is configured as I/O pin in the slave QUICC. The TPEN (Twisted-Pair Port Enable) pin in the EEST determines which port is selected to operate, AUI or TP.
4	CLSN	This pin is connected to the CLSN output of the EEST. It is configured as the CTS signal of SCC1 in the slave QUICC.
5	RENA	This pin is connected to the RENA output of the EEST. It is configured as the CD signal of SCC1 in the slave QUICC.
6	HSKI	This pin is connected to the HSKI signal of the AppleTalk port through the transceiver U29. It is configured as the CTS signal of SCC2 of the slave QUICC.
7	APORT	This pin is connected to the APORT input of the EEST, and it is configured as output pin in the slave QUICC. If this pin is '1', the EEST automatically select the TP or AUI port based on the TP receive input. If it is '0', the TPEN pin selects the operating port.
8	TPAPCE	This pin is connected to the TPAPCE input of the EEST, and it is configured as output pin in the slave QUICC. If this pin is '1', automatic polarity correction is enabled on the TP port.
9	TPSQEL	This pin is connected to the TPSQEL input of the EEST, and it is configured as output pin in the slave QUICC. If this pin is '0', it enables testing the EEST internal TP collision detect circuitry.
10	TPFULDL	This pin is connected to the TPFULDL input of the EEST, and it is configured as output pin in the slave QUICC. If this pin is '0', it allows simultaneous transmit and receive operation on the TP port without an indicated collision.
11	LOOP	This pin is connected to the LOOP input of the EEST, and it is configured as output pin in the slave QUICC. This pin enables diagnostic loopback in the EEST.

4.7.9.4 Slave QUICC Port E

Port E pins can be configured to operate in one of two dedicated peripheral functions. The PEPAR register configures the operation mode, as described in section 3.5.5 on page 19.

4.8 LOCAL BUS ARBITER (Sheet 9)

The local bus master can be one of the following:

- The master QUICC.
- An External Bus Master connected to the QUADS through the expansion connectors.
- The slave QUICC peripherals (One of the DMA channels, DRAM refresh, etc...).

The master QUICC is the local bus master during normal operation. The Local Bus Arbiter, U42 in sheet 9, is PAL16R4 device that uses the master QUICC arbitration logic to transfer the bus mastership to other masters.

The M68360QUADS has provision for the user to connect External Bus Master device to the local bus through the Expansion Connectors P1 and P2. The relevant control signals (EXTBR~, EXTBG~, and BGACK~) appear on connector P1. The arbitration priority from highest to lowest is slave QUICC, External Bus Master, and master QUICC.

The Bus Arbiter output signal A_DIR controls the direction of the address bus transceivers (U7, U6, U5, U28, U14, and U21 in sheet 5) between the master QUICC and the other devices on the QUADS.

U42 also generates the output signal A28_31, which is used by the data bus controller to determine the direction of the data bus transceivers.

4.9 DATA BUS CONTROLLER (Sheet 8)

The data and parity bus transceivers (U20,U15, U32, U12, U25, U13, U11, U18, and U19 in sheet 6) are controlled by a GAL22V10 device, U51 in sheet 8. U51 also generates the Byte Enable signals according to the accessed address and the data size.

The signals CS7~ of the slave QUICC and A28_31 of U42 are used to indicate if the current access is to one of the devices on the QUADS. The CS7~ signal is programmed for the address range 00000000 to 0FFFFFFF hexadecimal, with its DSACK generator disabled. The signal CS0~ of the slave QUICC is programmed to cover the address range of the Boot EPROM, so that CS7~ is not asserted if the EPROM is accessed. CS7~ is asserted if none of the slave QUICC chip-select signals is asserted, so If CS7~ is asserted (low), this indicates that the accessed device is not on the QUADS board.

The A28_31 signal is high if any of the upper four address bits A28 to A31 is high, or if external EPROM is accessed instead of the M68360QUADS Boot EPROM. If A28_31 is high, it indicates that the accessed device is not on the QUADS board.

The GAL22V10 device also control the data bus swapping if the master QUICC is configured to operate in 16 bits mode.

4.10 Status Register (Sheet 14)

The M68360QUADS Status Register consists of two 74LS373 devices (U61 and U39 in sheet 14) that form 16 bit read-only device. The register in controlled by CS4~ of the slave QUICC.

The Status Register bits are described in Table 4-5 below:

Table 4-5 Status Register Description

Bit No.	Description
0	Data Bus Configuration - This bit indicates the operation mode of the master QUICC data bus. If it is '1', the data bus is in 32 bit mode. If it is '0', the data bus is in 16 bit mode.
1	Interrupt Enable - This bit indicates if interrupts from the QUADS devices to the master QUICC are enabled. If this bit is '0', the master QUICC may be interrupted by the QUADS resources, such as the ABORT switch and the slave QUICC peripherals.
2	Clock Source - This bit indicates the source of the clock on the QUADS. If it is '1', the clock is supplied to the QUADS through the expansion connector P1. If the bit is '0', the clock is supplied by the QUADS clock generator.
3	A(31:28) Pins Configuration - These bits indicates to the CPU32bug software the required configuration of the master QUICC A(31:28) pins. If it is '1', the pins are configured as write enable signals. If it is '0', the pins are configured as address lines.
4	SIMM1 - This bit is connected to the DRAM SIMM presence detect signals. Refer to Table 4-1 for complete description of the available DRAM types, and their SIMM(4:1) codes.
5	SIMM2 - This bit is connected to the DRAM SIMM presence detect signals. Refer to Table 4-1 for complete description of the available DRAM types, and their SIMM(4:1) codes.
6	SIMM3 - This bit is connected to the DRAM SIMM presence detect signals. Refer to Table 4-1 for complete description of the available DRAM types, and their SIMM(4:1) codes.
7	SIMM4 - This bit is connected to the DRAM SIMM presence detect signals. Refer to Table 4-1 for complete description of the available DRAM types, and their SIMM(4:1) codes.
8	Host VCC - This bit is connected to the ADI port. If it is '0', it indicates that the host computer is powered on.
9	Host Enable - This bit is connected to the ADI port. If it is '1', it indicates that the ADI port is connected to a host computer.
10	Host Ack - This bit is connected to the ADI port. If it is '0', it indicates that the host has responded to the ADS REQ signal.
11	Host Req - This bit is connected to the ADI port. If it is '0', it indicates that the host is requesting to write to the QUADS.
12	ADS Select - This bit is connected to the ADI port. If it is '1', it indicates that the host computer has selected the QUADS for the current data transfer.
13	Interrupt Ack - This bit is connected to the ADI port. If it is '0', it indicates that the host has responded to the interrupt signal from the QUADS.
14	Host NMI - This bit is connected to the ADI port. If it is '0', it indicates that the host has generated a level 7 interrupt to the QUADS.
15	DTR~ - Data Terminal Ready indication. This bit indicates if a terminal is connected to the RS-232 Serial Port.

4.11 Interrupt Logic

The slave QUICC is configured by the CPU32bug software to assert its interrupt requests on its IOUT(2:0)~ pins. The 74F538 decoder (U70 in sheet 13) accepts the IOUT signals and decodes them to select one of the master QUICC IRQ(7:1)~ signals. The IRQ signals of the master QUICC are driven by open-collector devices, so that the user application connected to the expansion connectors P1 and P2 may assert them along with the interrupt logic on the QUADS board.

It is possible to disable U70 from driving the IRQ signals, so that the master QUICC can only be interrupted by its internal peripherals or by the user application. This is done by setting the Enable Interrupt switch in U52 to 'OFF'.

FIGURE 4-7 Interrupt Logic Configuration

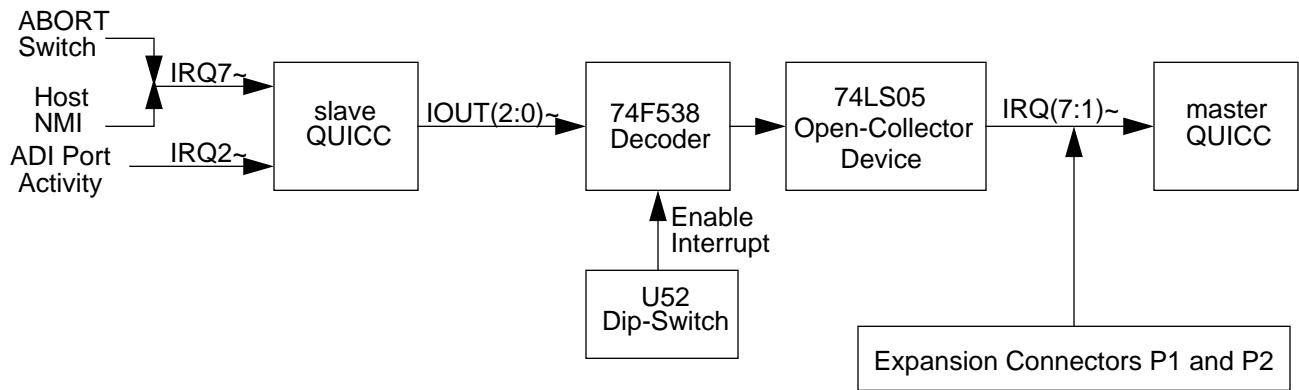

The slave QUICC accepts interrupts from the ABORT switch, the Host NMI register, and the ADI port logic. These interrupt sources are encoded by the slave QUICC, along with interrupts from its internal peripherals, and highest interrupt level is driven on the IOUT(2:0)~ pins. The slave QUICC may supply interrupt vector during interrupt acknowledge cycle for its internal interrupts, but it can not do that for the external interrupts. Therefore, the master QUICC must be programmed to provide auto-vector for interrupts in levels 2 and 7.

If the QUADS is configured to operate in 16 bit mode, the master QUICC can not read the interrupt vector generated by the slave QUICC during interrupt acknowledge cycles. In this case the auto-vector function must be used.

If an external interrupting device is connected to the QUADS, the auto-vector function must be used to handle its interrupts. This is because the interrupt acknowledge address space is occupied by the slave QUICC, and the external interrupter may not drive data during interrupt acknowledge cycles.

4.12 Disable CPU Logic for the Slave QUICC (Sheet 15)

The slave QUICC must be configured to work with its CPU disabled, its global CS disabled, and its MBAR to reside at address 3FF04. For this, the encoding of its configuration pins CONFIG(2:0) must enable the CPU for more than 32 clocks during hard reset, and then they must be encoded to '110' before the hard reset signal is negated (high level).

The CONFIG2 and CONFIG1 pins are connected to pull-up resistors on the QUADS. The CONFIG0 pin is driven by a PAL22V10-25 device, SP1 in sheet 15, during hard reset. SP1 drives CONFIG0 to high level for 64 clock cycles after the hard reset signal is asserted. This makes the encoding of CONFIG(2:0) pins equals '111' which enables the CPU. After 64 clocks, the CONFIG0 pin is driven low as long as the hard reset signal is asserted.



When the hard reset signal is negated, the CPU of the slave QUICC is disabled, and SP1 stops driving the CONFIG0 pin.

Freescale Semiconductor, Inc.

CHAPTER 5 - SUPPORT INFORMATION

5.1 INTRODUCTION

This chapter provides the interconnection signals, parts list, and schematic diagrams of the M68360QUADS board.

5.2 INTERCONNECT SIGNALS

The M68360QUADS board interconnects with external devices through the following connectors:

- PD1 - PD5 are five 20 pin, male connectors, compatible with HP logic analyzer connectors, that provides the bus signals of the master QUICC for bus monitoring.
- PD6 is 96 pin, male, logic analyzer connector providing the remaining signals of the master QUICC.
- P1 and P2 are two 96 pin, female, expansion connectors providing all the signals of the master QUICC for connection to the user hardware application.
- P3 is 8 pin male connector connected to the BDM pins of the master QUICC.
- P4 is 37 pin, male D type connector, for the ADI port.
- P5 is 9 pin, female D type connector, for the RS-232 port.
- P6 is 8 pin, MINI DIN JACK connector, for the AppleTalk port.
- P7 is 15 pin, female D type connector, for AUI connection to the Ethernet port.
- P8 is 8 pin, RJ-45 connector, for twisted-pair connection to the Ethernet port.
- P9 is 8 pin male connector. It is the BDM controller connector that enables the QUADS to control the activity of external QUICC mounted on the user application board.
- P10 is 16 wire holes on the board. The signals between the slave QUICC and the EEST appear on P10 for internal factory debugging purposes.
- P11 is 3 pin connector for 5v power supply input: GND (x2) and +5V
- P12 is 2 pin connector for 12v power supply input: GND and +12V

5.2.1 Connector PD1 Interconnect Signals

Connector PD1 is a double-row, 20 pin, male connector. The lower 16 address lines of the master QUICC appear on this connector for easy monitoring of the bus by a logic analyzer. Table 5-1 describes the connector signals.

Table 5-1 Connector PD1 Interconnect Signals

Pin No.	Signal Name	Description
1	-	Not connected
2	-	Not connected
3	CLK1	The operating clock of the M68360QUADS, 25 MHz.
4	A15	Address line 15 of the master QUICC (unbuffered).
5	A14	Address line 14 of the master QUICC (unbuffered).
6	A13	Address line 13 of the master QUICC (unbuffered).
7	A12	Address line 12 of the master QUICC (unbuffered).
8	A11	Address line 11 of the master QUICC (unbuffered).
9	A10	Address line 10 of the master QUICC (unbuffered).

Freescale Semiconductor, Inc.

Table 5-1 Connector PD1 Interconnect Signals

Pin No.	Signal Name	Description
10	A9	Address line 9 of the master QUICC (unbuffered).
11	A8	Address line 8 of the master QUICC (unbuffered).
12	A7	Address line 7 of the master QUICC (unbuffered).
13	A6	Address line 6 of the master QUICC (unbuffered).
14	A5	Address line 5 of the master QUICC (unbuffered).
15	A4	Address line 4 of the master QUICC (unbuffered).
16	A3	Address line 3 of the master QUICC (unbuffered).
17	A2	Address line 2 of the master QUICC (unbuffered).
18	A1	Address line 1 of the master QUICC (unbuffered).
19	A0	Address line 0 of the master QUICC (unbuffered).
20	GND	Ground signal of the M68360QUADS.

5.2.2 Connector PD2 Interconnect Signals

Connector PD2 is a double-row, 20 pin, male connector. The higher 16 address lines of the master QUICC appear on this connector for easy monitoring of the bus by a logic analyzer. Table 5-1 describes the connector signals.

Table 5-2 Connector PD2 Interconnect Signals

Pin No.	Signal Name	Description
1	-	Not connected
2	-	Not connected
3	DSACK0~	DSACK0~ line of the master QUICC.
4	A31	Address line 31 of the master QUICC (unbuffered).
5	A30	Address line 30 of the master QUICC (unbuffered).
6	A29	Address line 29 of the master QUICC (unbuffered).
7	A28	Address line 28 of the master QUICC (unbuffered).
8	A27	Address line 27 of the master QUICC (unbuffered).
9	A26	Address line 26 of the master QUICC (unbuffered).
10	A25	Address line 25 of the master QUICC (unbuffered).
11	A24	Address line 24 of the master QUICC (unbuffered).
12	A23	Address line 23 of the master QUICC (unbuffered).
13	A22	Address line 22 of the master QUICC (unbuffered).
14	A21	Address line 21 of the master QUICC (unbuffered).
15	A20	Address line 20 of the master QUICC (unbuffered).
16	A19	Address line 19 of the master QUICC (unbuffered).
17	A18	Address line 18 of the master QUICC (unbuffered).
18	A17	Address line 17 of the master QUICC (unbuffered).
19	A16	Address line 16 of the master QUICC (unbuffered).
20	GND	Ground signal of the M68360QUADS.

5.2.3 Connector PD3 Interconnect Signals

Connector PD3 is a double-row, 20 pin, male connector. The lower 16 data lines of the master QUICC appear on this connector for easy monitoring of the bus by a logic analyzer. Table 5-1 describes the connector signals.

Table 5-3 Connector PD3 Interconnect Signals

Pin No.	Signal Name	Description
1	-	Not connected
2	-	Not connected
3	DSACK1~	DSACK1~ line of the master QUICC.
4	D15	Data line 15 of the master QUICC (unbuffered).
5	D14	Data line 14 of the master QUICC (unbuffered).
6	D13	Data line 13 of the master QUICC (unbuffered).
7	D12	Data line 12 of the master QUICC (unbuffered).
8	D11	Data line 11 of the master QUICC (unbuffered).
9	D10	Data line 10 of the master QUICC (unbuffered).
10	D9	Data line 9 of the master QUICC (unbuffered).
11	D8	Data line 8 of the master QUICC (unbuffered).
12	D7	Data line 7 of the master QUICC (unbuffered).
13	D6	Data line 6 of the master QUICC (unbuffered).
14	D5	Data line 5 of the master QUICC (unbuffered).
15	D4	Data line 4 of the master QUICC (unbuffered).
16	D3	Data line 3 of the master QUICC (unbuffered).
17	D2	Data line 2 of the master QUICC (unbuffered).
18	D1	Data line 1 of the master QUICC (unbuffered).
19	D0	Data line 0 of the master QUICC (unbuffered).
20	GND	Ground signal of the M68360QUADS.

5.2.4 Connector PD4 Interconnect Signals

Connector PD4 is a double-row, 20 pin, male connector. The higher 16 data lines of the master QUICC appear on this connector for easy monitoring of the bus by a logic analyzer. Table 5-1 describes the connector signals.

Table 5-4 Connector PD4 Interconnect Signals

Pin No.	Signal Name	Description
1	-	Not connected
2	-	Not connected
3	DS~	Data Strobe line of the master QUICC.
4	D31	Data line 31 of the master QUICC (unbuffered).
5	D30	Data line 30 of the master QUICC (unbuffered).
6	D29	Data line 29 of the master QUICC (unbuffered).
7	D28	Data line 28 of the master QUICC (unbuffered).
8	D27	Data line 27 of the master QUICC (unbuffered).

Table 5-4 Connector PD4 Interconnect Signals

Pin No.	Signal Name	Description
9	D26	Data line 26 of the master QUICC (unbuffered).
10	D25	Data line 25 of the master QUICC (unbuffered).
11	D24	Data line 24 of the master QUICC (unbuffered).
12	D23	Data line 23 of the master QUICC (unbuffered).
13	D22	Data line 22 of the master QUICC (unbuffered).
14	D21	Data line 21 of the master QUICC (unbuffered).
15	D20	Data line 20 of the master QUICC (unbuffered).
16	D19	Data line 19 of the master QUICC (unbuffered).
17	D18	Data line 18 of the master QUICC (unbuffered).
18	D17	Data line 17 of the master QUICC (unbuffered).
19	D16	Data line 16 of the master QUICC (unbuffered).
20	GND	Ground signal of the M68360QUADS.

5.2.5 Connector PD5 Interconnect Signals

Connector PD5 is a double-row, 20 pin, male connector. The master QUICC bus control signals appear on this connector for easy monitoring of the bus by a logic analyzer. Table 5-1 describes the connector signals.

Table 5-5 Connector PD5 Interconnect Signals

Pin No.	Signal Name	Description
1	-	Not connected
2	-	Not connected
3	AS~	Address Strobe
4	BERR~	Bus Error
5	PERR~	Parity Error
6	IFETCH~	Instruction Fetch
7	IPIPE0~	Instruction Pipe 0
8	IPIPE1~	Instruction Pipe 1
9	FREEZE	Freeze
10	FC3	Function Code 3
11	DSACK1~	Data and Size Acknowledge 1
12	DSACK0~	Data and Size Acknowledge 0
13	FC2	Function Code 2
14	FC1	Function Code 1
15	FC0	Function Code 0
16	SIZ1	Transfer Size 1
17	SIZ0	Transfer Size 0
18	R/W~	Read / Write
19	BGACK~	Bus Grant Acknowledge
20	GND	Ground signal of the M68360QUADS.

5.2.6 Connector PD6 Interconnect Signals

Connector PD6 is a triple-row, 96 pin, male DIN connector. The remaining signals of the master QUICC appear on this connector. Table 5-1 describes the connector signals.

Table 5-6 Connector PD6 Interconnect Signals

Pin No.	Signal Name	Description
A1 - A16	PA0 - PA15	Port A pins 0 to 15 of the master QUICC
A17	VCC	+5V
A18 - A21	PRTY0 - PRTY3	Parity lines 0 to 3
A22, A23	GND	Ground signal of the M68360QUADS
A24 - A30	IRQ1~ - IRQ7~	Interrupt request signals 1 to 7 of the master QUICC
A31	AVEC~	Auto vector pin of the master QUICC
A32	GND	Ground signal of the M68360QUADS
B1 - B18	PB0 - PB17	Port B pins 0 to 17 of the master QUICC
B19	GND	Ground signal of the M68360QUADS
B20 - B31	PC0 - PC11	Port C pins 0 to 11 of the master QUICC
B32	GND	Ground signal of the M68360QUADS
C1 - C4	CAS0~ - CAS3~	CAS signals 0 to 3 of the master QUICC
C5	VCC	+5V
C6 - C13	CS0~ - CS7~	Chip select signals 0 to 7 of the master QUICC
C14	HALT~	HALT~ pin of the master QUICC
C15	AMUX	AMUX/OE~ pin of the master QUICC
C16	TCK	TCK pin of the master QUICC
C17	TMS	TMS pin of the master QUICC
C18	TDI	TDI pin of the master QUICC
C19	TDO	TDO pin of the master QUICC
C20	TRST~	TRST~ pin of the master QUICC
C21	BKPT~	Breakpoint pin of the master QUICC
C22	RESETH~	Hard reset pin of the master QUICC
C23	RESETS~	Soft reset pin of the master QUICC
C24	CONFIG0	RMC~/CONFIG0 pin of the master QUICC
C25	CONFIG1	CONFIG1 pin of the master QUICC
C26	TRIS~	TRIS~ pin of the master QUICC
C27	MODCK0	Clock mode select 0 pin of the master QUICC
C28	MODCK1	Clock mode select 1 pin of the master QUICC
C29	GND	Ground signal of the M68360QUADS
C30	CLKO2	System clock out 2 pin of the master QUICC, 50 MHz.
C31	GND	Ground signal of the M68360QUADS
C32	CLK2	The operating clock of the M68360QUADS, 25 MHz.

5.2.7 Connector P1 Interconnect Signals

Connector P1 is a triple-row, 96 pin, female DIN connector. P1 and P2 expansion connectors provide all the signals of the master QUICC. Table 5-1 describes the P1 connector signals.

Table 5-7 Connector P1 Interconnect Signals

Pin No.	Signal Name	Description
A1 - A32	A0 - A31	Address lines 0 to 31 of the master QUICC
B1 - B32	D0 - D31	Data lines 0 to 31 of the master QUICC
C1 - C4	FC0 - FC3	Function code lines 0 to 3 of the master QUICC
C5	AMUX	AMUX/OE~ pin of the master QUICC
C6, C7	SIZ0, SIZ1	Transfer Size 0 and 1 lines of the master QUICC
C8	EXTBR~	External master bus request input to the Local Bus Arbiter
C9	EXTBG~	External master bus grant output from the Local Bus Arbiter
C10	BGACK~	Bus grant acknowledge line
C11	AS~	Address strobe line
C12	GND	Ground signal of the M68360QUADS
C13	DS~	Data strobe line
C14	R/W~	Read/Write~ line
C15	VCC	+5V
C16	CONFIG0	RMC~/CONFIG0 pin of the master QUICC
C17	CONFIG1	CONFIG1 pin of the master QUICC
C18	DSACK0~	Data and size acknowledge 0 line of the master QUICC
C19	DSACK1~	Data and size acknowledge 1 line
C20	BERR~	Bus error line of the master QUICC
C21	HALT~	HALT~ pin of the master QUICC
C22	RESETH~	Hard reset pin of the master QUICC
C23	RESETS~	Soft reset pin of the master QUICC
C24	PERR~	Parity error pin of the master QUICC
C25	VCC	+5V
C26	TRIS~	TRIS~ pin of the master QUICC
C27	MODCK0	Clock mode select 0 pin of the master QUICC
C28	MODCK1	Clock mode select 1 pin of the master QUICC
C29	GND	Ground signal of the M68360QUADS
C30	CLK1	The operating clock of the M68360QUADS, 25 MHz.
C31	GND	Ground signal of the M68360QUADS
C32	CLK2	The operating clock of the M68360QUADS, 25 MHz.

Freescale Semiconductor, Inc.

5.2.8 Connector P2 Interconnect Signals

Connector P2 is a triple-row, 96 pin, female DIN connector. P1 and P2 expansion connectors provide all the signals of the master QUICC. Table 5-1 describes the P2 connector signals.

Table 5-8 Connector P2 Interconnect Signals

Pin No.	Signal Name	Description
A1 - A16	PA0 - PA15	Port A pins 0 to 15 of the master QUICC
A17	VCC	+5V
A18 - A21	PRTY0 - PRTY3	Parity lines 0 to 3
A22, A23	GND	Ground signal of the M68360QUADS
A24 - A30	IRQ1~ - IRQ7~	Interrupt request signals 1 to 7 of the master QUICC
A31	AVEC~	Auto vector pin of the master QUICC
A32	GND	Ground signal of the M68360QUADS
B1 - B18	PB0 - PB17	Port B pins 0 to 17 of the master QUICC
B19	GND	Ground signal of the M68360QUADS
B20 - B31	PC0 - PC11	Port C pins 0 to 11 of the master QUICC
B32	GND	Ground signal of the M68360QUADS
C1 - C4	CAS0~ - CAS3~	CAS signals 0 to 3 of the master QUICC
C5	VCC	+5V
C6 - C13	CS0~ - CS7~	Chip select signals 0 to 7 of the master QUICC
C14	GND	Ground signal of the M68360QUADS
C15	FREEZE	FREEZE pin of the master QUICC
C16	TCK	TCK pin of the master QUICC
C17	TMS	TMS pin of the master QUICC
C18	TDI	TDI pin of the master QUICC
C19	TDO	TDO pin of the master QUICC
C20	TRST~	TRST~ pin of the master QUICC
C21	BKPT~	Breakpoint pin of the master QUICC
C22	RESETH~	Hard reset pin of the master QUICC
C23	RESETS~	Soft reset pin of the master QUICC
C24	IFETCH~	Instruction fetch pin of the master QUICC
C25	VCC	+5V
C26	IPIPE0~	Instruction pipe 0 pin of the master QUICC
C27	IPIPE1~	Instruction pipe 1 pin of the master QUICC
C28	VPP	+12V
C29	GND	Ground signal of the M68360QUADS
C30	CLKO2	System clock out 2 pin of the master QUICC, 50 MHz.
C31	GND	Ground signal of the M68360QUADS
C32	CLK2	The operating clock of the M68360QUADS, 25 MHz.

5.2.9 Connector P3 Interconnect Signals

Connector P3 is a double-row, 8 pin, male connector. It provides the BDM signals of the master QUICC, so that it can be controlled by external BDM controller. Table 5-1 describes the P3 connector signals.

Table 5-9 Connector P3 Interconnect Signals

Pin No.	Signal Name	Description
1	GND	Ground signal of the M68360QUADS
2	BKPT~	Breakpoint pin of the master QUICC
3	GND	Ground signal of the M68360QUADS
4	FREEZE	FREEZE pin of the master QUICC
5	RESETH~	Hard reset pin of the master QUICC
6	IFETCH~	Instruction fetch pin of the master QUICC
7	VCC	+5V
8	IPIPE0~	Instruction pipe 0 pin of the master QUICC

5.2.10 Connector P4 Interconnect Signals

Connector P4 is a 37 pin, male D type connector. It is the ADI port of the M68360QUADS. Table 5-1 describes the P4 connector signals.

Table 5-10 Connector P4 Interconnect Signals

Pin No.	Signal Name	Description
1	INT_ACK	Interrupt Acknowledge input signal from the host
2	-	Not connected
3	HST_ACK	Host Acknowledge input signal from the host
4	ADS_ALL	QUADS All input signal from the host
5	ADS_RESET	QUADS Reset input signal from the host
6	ADS_SEL2	QUADS Select 2 input signal from the host
7	ADS_SEL1	QUADS Select 1 input signal from the host
8	ADS_SEL0	QUADS Select 0 input signal from the host
9	HOST_REQ	HOST Request input signal from the host
10	ADS_REQ	QUADS Request output signal from the M68360QUADS to the host
11	ADS_ACK	QUADS Acknowledge output signal from the M68360QUADS to the host
12	ADS_INT	QUADS Interrupt output signal from the M68360QUADS to the host
13	HOST_BRK~	HOST Break open collector output signal from the M68360QUADS to the host
14	ADS_BRK	QUADS Break input signal from the host
15	-	Not connected
16	PD1	Bit 1 of the ADI port data bus
17	PD3	Bit 3 of the ADI port data bus
18	PD5	Bit 5 of the ADI port data bus
19	PD7	Bit 7 of the ADI port data bus
20 - 25	GND	Ground signal of the M68360QUADS
26	-	Not connected. The host supplies +12V on this pin, but it is not connected on the M68360QUADS

Table 5-10 Connector P4 Interconnect Signals

Pin No.	Signal Name	Description
27 - 29	HOST_VCC	HOST VCC input from the host. The M68360QUADS does not use these inputs for power supply.
30	HOST_ENABLE~	HOST Enable input signal from the host.
31 - 33	GND	Ground signal of the M68360QUADS
34	PD0	Bit 0 of the ADI port data bus
35	PD2	Bit 2 of the ADI port data bus
36	PD4	Bit 4 of the ADI port data bus
37	PD6	Bit 6 of the ADI port data bus

5.2.11 Connector P5 Interconnect Signals

Connector P5 is a 9 pin, female D type connector. It is the RS-232 serial port of the M68360QUADS. Table 5-1 describes the P5 connector signals.

Table 5-11 Connector P5 Interconnect Signals

Pin No.	Signal Name	Description
1	CD	Carrier Detect output from the M68360QUADS.
2	TX	Transmit Data output from the M68360QUADS.
3	RX	Receive Data input to the M68360QUADS.
4	DTR	Data Terminal Ready input to the M68360QUADS.
5	GND	Ground signal of the M68360QUADS.
6	DSR	Data Set Ready output from the M68360QUADS.
7	RTS (N.C.)	Request To Send. This line is not connected in the M68360QUADS.
8	CTS	Clear To Send output from the M68360QUADS.
9	-	Not connected

5.2.12 Connector P6 Interconnect Signals

Connector P6 is 8 pin, MINI DIN JACK connector. It is the AppleTalk port of the M68360QUADS board. Table 5-1 describes the P6 connector signals.

Table 5-12 Connector P6 Interconnect Signals

Pin No.	Signal Name	Description
1	VCC	+5V output from the M68360QUADS through 100 ohm resistor.
2	HSKI	Hand Shake Input signal.
3	TX-	Transmit Data negative output from the M68360QUADS.
4	GND	Ground signal of the M68360QUADS.
5	RX-	Receive Data negative input to the M68360QUADS.
6	TX+	Transmit Data positive output from the M68360QUADS.
7	-	Not connected
8	RX+	Receive Data positive input to the M68360QUADS.

5.2.13 Connector P7 Interconnect Signals

Connector P7 is 15 pin, female D type connector. It is the AUI Ethernet port of the M68360QUADS board. Table 5-1 describes the P7 connector signals.

Table 5-13 Connector P7 Interconnect Signals

Pin No.	Signal Name	Description
1	GND	Ground signal of the M68360QUADS.
2	ACX+	Collision detect positive input to the M68360QUADS.
3	ATX+	Transmit Data positive output from the M68360QUADS.
4	GND	Ground signal of the M68360QUADS.
5	ARX+	Receive Data positive input to the M68360QUADS.
6	GND	Ground signal of the M68360QUADS.
7	-	Not connected
8	GND	Ground signal of the M68360QUADS.
9	ACX-	Collision detect negative input to the M68360QUADS.
10	ATX-	Transmit Data negative output from the M68360QUADS.
11	GND	Ground signal of the M68360QUADS.
12	ARX-	Receive Data negative input to the M68360QUADS.
13	VPP	+12V power supply from the M68360QUADS.
14	GND	Ground signal of the M68360QUADS.
15	-	Not connected

5.2.14 Connector P8 Interconnect Signals

Connector P8 is 8 pin, RJ-45 connector. It is the twisted-pair Ethernet port of the M68360QUADS board. Table 5-1 describes the P8 connector signals.

Table 5-14 Connector P8 Interconnect Signals

Pin No.	Signal Name	Description
1	TPTX+	Twisted-Pair Transmit Data positive output from the M68360QUADS.
2	TPTX-	Twisted-Pair Transmit Data negative output from the M68360QUADS.
3	TPRX+	Twisted-Pair Receive Data positive input to the M68360QUADS.
4	-	Not connected
5	-	Not connected
6	TPRX-	Twisted-Pair Receive Data negative input to the M68360QUADS.
7	-	Not connected
8	-	Not connected

Freescale Semiconductor, Inc.

5.2.15 Connector P9 Interconnect Signals

Connector P9 is a double-row, 8 pin, male connector. It is the BDM controller port, that enables the M68360QUADS to control external QUICC devices. The slave QUICC general purpose I/O pins are connected to P9. Table 5-1 describes the P9 connector signals.

Table 5-15 Connector P9 Interconnect Signals

Pin No.	Signal Name	Description
1	GND	Ground signal of the M68360QUADS.
2	BDMCLK	This signal is connected to Port B pin 4 in the slave QUICC. It should be connected to the breakpoint pin of the external QUICC device.
3	GND	Ground signal of the M68360QUADS.
4	BDMFRZ	This signal is connected to Port B pin 9 in the slave QUICC. It should be connected to the FREEZE pin of the external QUICC device.
5	BDMRST	This signal is connected to Port B pin 5 in the slave QUICC. It should be connected to the Hard reset pin of the external QUICC device.
6	BDMDSI	This signal is connected to Port B pin 7 in the slave QUICC. It should be connected to the Instruction fetch pin of the external QUICC device.
7	VCC	+5V
8	BDMDSO	This signal is connected to Port B pin 6 in the slave QUICC. It should be connected to the Instruction pipe 0 pin of the external QUICC device.

5.2.16 Connector P10 Interconnect Signals

Connector P10 is a double-row, 16 pin wire holes on the M68360QUADS. It provides all the signals between the slave QUICC and the EEST. This connector is used for internal factory testing of the board. Table 5-1 describes the P10 connector signals.

Table 5-16 Connector P10 Interconnect Signals

Pin No.	Signal Name	Description
1	Ethernet TX	This pin is connected to Port A pin 1 in the slave QUICC and to the transmit data input of the EEST.
2	TENA	This pin is connected to Port C pin 0 in the slave QUICC and to the TENA input of the EEST.
3	Ethernet TCLK	This pin is connected to Port A pin 8 in the slave QUICC and to the TCLK output of the EEST.
4	Ethernet RX	This pin is connected to Port A pin 0 in the slave QUICC and to the receive data output of the EEST.
5	RENA	This pin is connected to Port C pin 5 in the slave QUICC and to the RENA output of the EEST.
6	Ethernet RCLK	This pin is connected to Port A pin 9 in the slave QUICC and to the RCLK output of the EEST.
7	CLSN	This pin is connected to Port C pin 4 in the slave QUICC and to the CLSN output of the EEST.
8	EEST CS0	This pin is connected to the EEST CS0 input pin. This signal is not driven by the slave QUICC, and it is connected to pull-up resistor.
9	EEST CS1	This pin is connected to the EEST CS1 input pin. This signal is not driven by the slave QUICC, and it is connected to pull-up resistor.

Table 5-16 Connector P10 Interconnect Signals

Pin No.	Signal Name	Description
10	EEST CS2	This pin is connected to Port C pin 2 in the slave QUICC and to the CS2 input of the EEST.
11	TPEN	This pin is connected to Port C pin 3 in the slave QUICC and to the TPEN I/O pin of the EEST.
12	APOINT	This pin is connected to Port C pin 7 in the slave QUICC and to the APOINT input of the EEST.
13	TPAPCE	This pin is connected to Port C pin 8 in the slave QUICC and to the TPAPCE input of the EEST.
14	TPSQEL	This pin is connected to Port C pin 9 in the slave QUICC and to the TPSQEL input of the EEST.
15	TPFULDL	This pin is connected to Port C pin 10 in the slave QUICC and to the TPFULDL input of the EEST.
16	LOOP	This pin is connected to Port C pin 11 in the slave QUICC and to the LOOP input of the EEST.

5.2.17 Connector P11 Interconnect Signals

Connector P11 is 3 pin connector for 5v power supply. The connector is supplied with 3 pin plug for convenient connection to the power supply. Table 5-1 describes the P11 connector signals.

Table 5-17 Connector P11 Interconnect Signals

Pin No.	Signal Name	Description
1	VCC	+5V connection to the power supply.
2	GND	Ground connection to the power supply.
3	GND	Ground connection to the power supply.

5.2.18 Connector P12 Interconnect Signals

Connector P12 is 2 pin connector for 12v power supply. The connector is supplied with 2 pin plug for convenient connection to the power supply. Table 5-1 describes the P12 connector signals.

Table 5-18 Connector P12 Interconnect Signals

Pin No.	Signal Name	Description
1	VPP	+12V connection to the power supply.
2	GND	Ground connection to the power supply.

Freescale Semiconductor, Inc.

5.3 M68360QUADS Parts List

The components of the M68360QUADS and their reference designation are listed in Table 5-19.

Table 5-19 Parts List

Reference Designation	Part Description	Notes
U1, U3	Resistor Network, 16 pins, 22 ohm	SMD
U2	I.C. 74LS245	SMD
U4, U8	I.C. MC68360 QUICC	socket mounted
U5 - U7, U11 - U15, U18 - U20, U25, U28, U32	I.C. 74F245	SMD
U9, U16	I.C. 74LS240	SMD
U10	I.C. 74LS85	SMD
U17, U26, U34 U36 - U38, U49, U50, U55, U60, U69	Resistor Network, 14 pins, 4700 ohm	SMD
U21	I.C. 74ACT244	SMD
U22	I.C. 74ACT74	SMD
U23	I.C. MC145407	SMD
U24	Factory testing socket	
U27	50 MHz Clock Oscillator	socket mounted
U29	I.C. MC34050	SMD
U30	I.C. PE64503	DIP
U31, U68	I.C. 74LS74	SMD
U33	I.C. MCM2814 serial EEPROM	DIP
U35	I.C. MC68160 EEST	TQFP
U39, U61	I.C. 74LS373	SMD
U40	LAF10T-3B Ethernet filter	SIL
U41	LAF10T-7B Ethernet filter	SIL
U42	I.C. Programmed PAL16R4-7	socket mounted
U43	I.C. Programmed PAL22V10-25	socket mounted
U44	I.C. PE65263	DIP
U45	I.C. PE65260	DIP
U46	Dip-Switch SPST4, 8 pin	SMD
U47	I.C. 74F04	SMD
U48	I.C. 27010-20 EPROM	socket mounted
U51	I.C. Programmed GAL22V10-7	socket mounted
U52	Dip-Switch SPST8, 16 pin	SMD
U53, U62, U67	I.C. 74F157A	SMD

Table 5-19 Parts List

Reference Designation	Part Description	Notes
U54	I.C. 74LS00	SMD
U56, U58, U59	I.C. 74F32	SMD
U57, U65	I.C. 74F08	SMD
U63	I.C. 74F00	SMD
U64, U66	I.C. 74LS05	SMD
U70	I.C. 74F538	SMD
U71	SIMM DRAM MCM36256S80	with SIMM socket
U72-U75	I.C. 28F010-120 Flash Memory	PLCC
SP1	I.C. Programmed PAL22V10-25	T.H.
C1, C2	Capacitor 390 pF ceramic	T.H.
C3 - C6	Capacitor 10 μ F electrolytic	SMD
C7, C8	Capacitor 100 μ F electrolytic	T.H.
C9 - C35, C40, C41, C43 - C51, C55, C57 - C95, CT0	Capacitor 0.1 μ F	SMD
C36, C37	Capacitor 100 pF	SMD
C38	Capacitor 680 pF	SMD
C39	Capacitor 22 pF	SMD
C42	Capacitor 4700 pF	SMD
C52	Capacitor 3900 pF	SMD
C53, C54	Capacitor 68 pF	SMD
C56	Capacitor 0.039 μ F	SMD
CA1 - CA5	Capacitor 150 pF	SMD
CX1 - CX4	Not mounted. Used for factory testing.	
R2,R25	Resistor 100 ohm	SMD
R3	Resistor 3 Kohm	SMD
R4	Resistor 510 ohm	SMD
R5 - R7, R11, R23, R26	Resistor 39 ohm	SMD
R1, R8 - R10, R12 - R16, R18	Resistor 25 ohm	SMD
R17	Resistor 294 ohm	SMD
R19, R20, R22 R24, R27	Resistor 332 ohm	SMD
R21	Resistor 22 Kohm	SMD
R28	Resistor 243 ohm	SMD
R29, R30	Resistor 150 ohm	SMD
RS1, RS2	Resistor 1 Kohm	SMD

Table 5-19 Parts List

Reference Designation	Part Description	Notes
RT0	Resistor 51 ohm	SMD
RX1 - RX4	Not mounted. Used for factory testing.	
P1, P2	Connector 96 pin DIN female 90 degrees. Compatible wire-wrap connectors are supplied with the M68360QUADS.	
P3, P9	Connector 8 pin	2 row pins
P4	Connector 37 pin D type male	
P5	Connector 9 pin D type female	
P6	Connector 8 pin mini DIN jack	
P7	Connector 15 pin D type female	
P8	Connector 8 pin RJ-45	
P10	16 wire holes for EEST signals	
P11	Power connector, 3 pin with plug	5v power supply
P12	Power connector, 2 pin with plug	12v power supply
PD1 - PD5	Connector 20 pin DIN male. Compatible with HP logic analyzers	
PD6	Connector 96 pin DIN male straight	
LD1, LD5 LD7, LD8	LED RED	SMD
LD2 - LD4	LED GREEN	SMD
LD6	LED YELLOW	SMD
D1, D2	MBRD620CT diode	SMD
DZ1	1SMC5.0AT3	SMD
DZ2	1SMC12AT3	SMD
F1, F2	Fuse block with 5A Fuse	Fuse for 5v supply
F3, F4	Fuse block with 2A Fuse	Fuse for 12v supply
SW1	Switch, push-button, SPDT	with Red cap
SW2	Switch, push-button, SPDT	with Orange cap
SW3	Switch, push-button, SPDT	with Black cap
XT1, XT2	Not mounted. Used for factory testing.	
XT3, XT4	20 MHz	SMD

APPENDIX A - ADI BOARD INSTALLATION

A.1 INTRODUCTION

This appendix describes the hardware installation of the ADI board into various host computers. The installation instructions cover the following host computers:

1. IBM-PC/XT/AT
2. SUN - 4 (SBus interface)

A.2 IBM-PC/XT/AT to M68360QUADS Interface

The ADI board should be installed in one of the IBM-PC/XT/AT motherboard system expansion slots. A single ADI can control up to eight M68360QUADS boards. The ADI address in the computer is configured to be at I/O memory addresses 100-102 (hex), but it may be reconfigured for an alternate address space.

CAUTION

BEFORE REMOVING OR INSTALLING ANY
EQUIPMENT IN THE IBM-PC/XT/AT
COMPUTER, TURN THE POWER OFF AND
REMOVE THE POWER CORD.

A.2.1 ADI Installation in IBM-PC/XT/AT

Refer to the appropriate Installation and Setup manual of the IBM-PC/XT/AT computer for instructions on removing the computer cover.

The ADI board address block should be configured at a free I/O address space in the computer. The address must be unique and it must not fall within the address range of another card installed in the computer.

The ADI board address block can be configured to start at one of the three following addresses:

- \$100 - This address is unassigned in the IBM-PC
- \$200 - This address is usually used for the game port
- \$300 - This address is defined as a prototype port

The ADI board is factory configured for address decoding at 100-102 hex in the IBM-PC/XT/AT I/O address map. These are undefined peripheral addresses.

FIGURE A-1 Physical Location of jumper JG1 and JG2

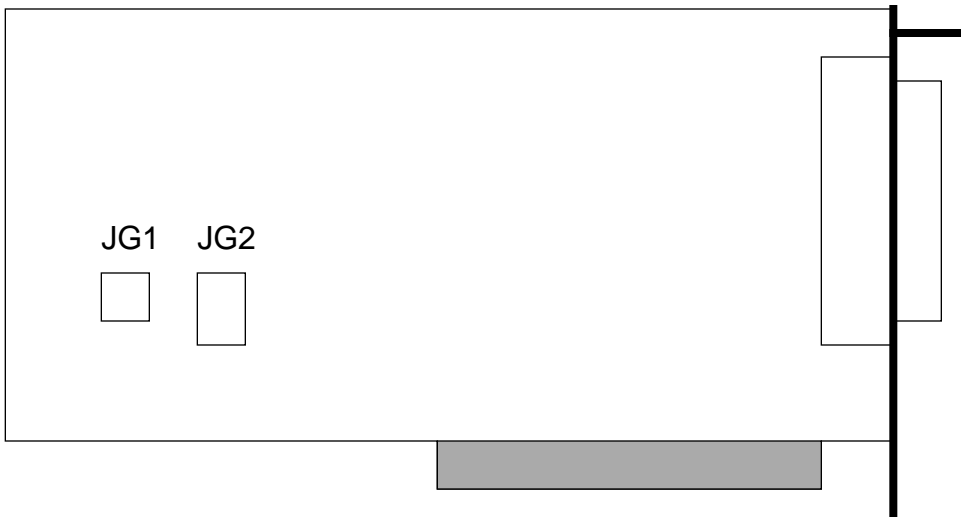

NOTE: Jumper JG2 should be left unconnected.

The following figure shows the required jumper connection for each address configuration. Address 0 hex is not recommended, and its usage might cause problems.

FIGURE A-2 JG1 Configuration Options

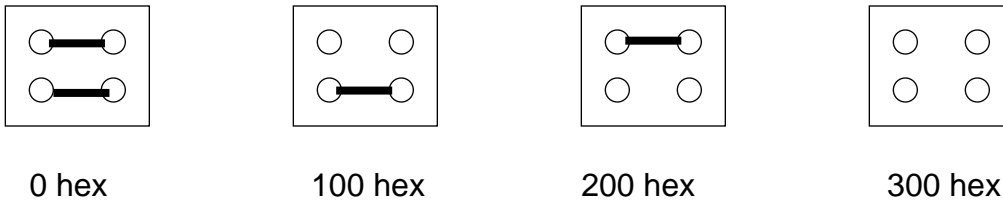

0 hex

100 hex

200 hex

300 hex

To properly install the ADI board, position its front bottom corner in the plastic card guide channel at the front of the IBM-PC/XT/AT chassis. Keeping the top of the ADI board level and any ribbon cables out of the way, lower the board until its connectors are aligned with the computer expansion slot connectors. Using evenly distributed pressure, press the ADI board straight down until it seats in the expansion slot.

Secure the ADI board to the computer chassis using the bracket retaining screw. Refer to the computer Installation and Setup manual for instructions on reinstalling the computer cover.

A.3 SUN-4 to M68360QUADS Interface

The ADI board should be installed in one of the SBus expansion slots in the Sun-4 SPARCstation computer. A single ADI can control up to eight M68360QUADS boards.

CAUTION

BEFORE REMOVING OR INSTALLING ANY EQUIPMENT IN THE SUN-4 COMPUTER, TURN THE POWER OFF AND REMOVE THE POWER CORD.

A.3.1 ADI Installation in the SUN-4

There are no jumper options on the ADI board for the Sun-4 computer. The ADI board can be inserted into any available SBus expansion slot on the motherboard.

Refer to the appropriate Installation and Setup manual for the Sun-4 computer for instructions on removing the computer cover and installing the board in an expansion slot.

FIGURE A-3 ADI board for SBus

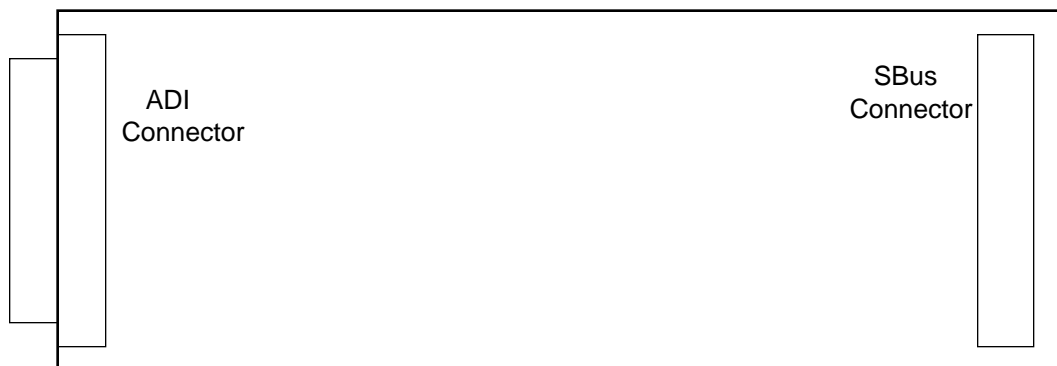

Following is a summary of the Instructions in the Sun manual:

1. Turn off power to the system, but keep the power cord plugged in. Be sure to save all open files and then the following steps should shut down your system:
 - hostname% /bin/su
 - Password: mypasswd
 - hostname# /usr/etc/halt
 - wait for the following messages.
Syncing file systems... done
Halted
Program Terminated
Type b(boot), c(continue), n(new command mode)
 - When these messages appear, you can safely turn off the power to the system unit.
2. Open the system unit. Be sure to attach a grounding strap to your wrist and to the metal casing of the power supply. Follow the instructions supplied with your system to gain access to the SBus slots.

3. Remove the SBus slot filler panel for the desired slot from the inner surface of the back panel of the system unit. Note that the ADI board is a slave only board and thus will function in any available SBus slot.
4. Slide the ADI board at an angle into the back panel of the system unit. Make sure that the mounting plate on the ADI board hooks into the holes on the back panel of the system unit.
5. Push the ADI board against the back panel and align the connector with its mate and gently press the corners of the board to seat the connector firmly.
6. Close the system unit.
7. Connect the 37 pin interface flat cable to the ADI board and secure.
8. Turn power on to the system unit and check for proper operation.

APPENDIX B - ADI PORT HANDSHAKE DESCRIPTION

B.1 INTRODUCTION

In this appendix, the ADI port signals and the handshake procedure are explained. The M68360QUADS ADI port can be connected to an ADI board mounted in a host computer.

There are ADI boards for the following host computers:

1. IBM-PC/XT/AT
2. SUN - 4 (SBus interface)

B.2 ADI Port Concept and Operation Description

Each ADI board can be connected to up to 8 M68360QUADS boards. Each M68360QUADS has its own address which is fixed by setting Dip-Switch U46 on the board. Refer to section 2.3.1 on page 9.

The following operations can be performed using the ADI port :

- The host computer can write a byte to the M68360QUADS
- The M68360QUADS can write a byte to the host computer
- The M68360QUADS can interrupt the host computer
- The host computer can interrupt the M68360QUADS (interrupt level 7)
- The host computer can reset (soft or hard) the M68360QUADS

If more than one M68360QUADS is connected to the same ADI board, the host computer can perform the following operations simultaneously on all M68360QUADS boards :

- Abort all boards (interrupt level 7)
- Reset all boards

B.3 Handshake Description

Every action between the M68360QUADS and the host is asynchronous and is implemented by asserting and negating handshake signals by software.

All signals have TTL levels. A control signal is asserted if it is driven to logic '1' TTL level, and it is negated if it is driven to logic '0' level.

The connection between the host computer and the M68360QUADS is shown in FIGURE B-1 below.

FIGURE B-1 Host Computer (ADI) to M68360QUADS Connection

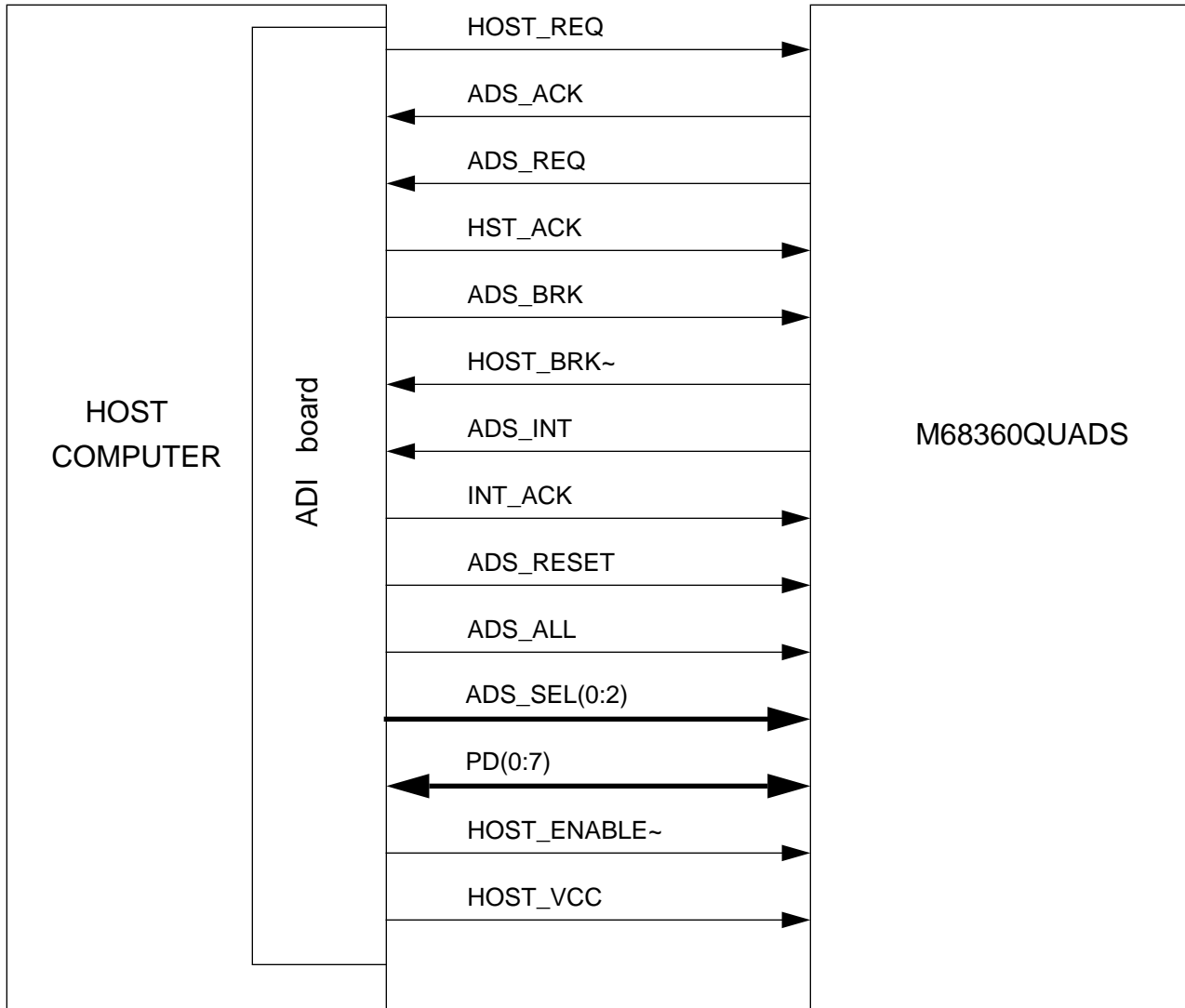

Freescale Semiconductor, Inc.

B.3.1 Write Cycle from Host to M68360QUADS

The application software in the Host uses the handshake signals to coordinate data transfer across the parallel link. The CPU32bug software in the M68360QUADS is responsible for accepting the data and responding to the handshake signals. The signals are shown in FIGURE B-2.

The sequence of events during a byte write to the M68360QUADS is as follows:

1. The Host selects the M68360QUADS board by putting the board's address on the ADS_SEL(0:2) signals.
2. The Host places a data byte in the data bus latch (buffer is in high-impedance state).
3. The Host asserts the HOST_REQ signal (the data buffer is enabled, data appears on the bus).
4. The M68360QUADS detects the HOST_REQ signal and reads the data byte.
5. The M68360QUADS asserts the ADS_ACK signal.
6. The Host detects the ADS_ACK signal and negates the HOST_REQ signal (data buffer is disabled).
7. The M68360QUADS detects the negation of HOST_REQ signal and negates ADS_ACK to end the cycle.

FIGURE B-2 Host Write to M68360QUADS

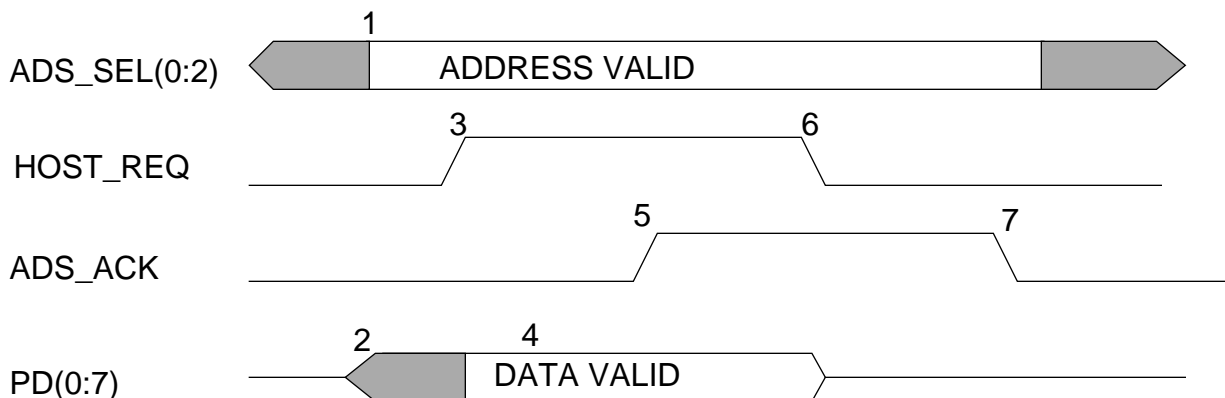

B.3.2 Write Cycle from M68360QUADS to Host

The signal handshake during an M68360QUADS to Host write cycle is shown in FIGURE B-3. The sequence of events is as follows:

1. The M68360QUADS places a data byte on the parallel port data bus (buffer disabled) and asserts the ADS_REQ signal. (the ADS_REQ signal will not appear on the port until the board is selected by the Host)
2. The Host polls each M68360QUADS address and detects the ADS_REQ signal from the requesting board. The Host asserts the HST_ACK signal in response, which enables the data buffer in the M68360QUADS.
3. The M68360QUADS negates the ADS_REQ signal. The data appears on the bus as long as the HST_ACK signal is asserted.
4. The Host reads the data.
5. The Host negates the HST_ACK signal to end the cycle. The M68360QUADS ends the cycle.

FIGURE B-3 M68360QUADS Write Cycle to Host

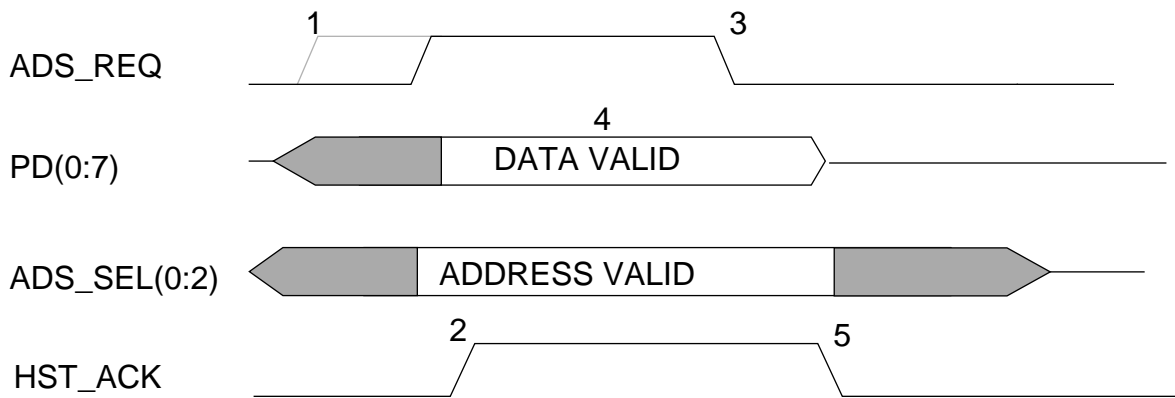

B.3.3 M68360QUADS Interrupt to the Host

The M68360QUADS can generate an interrupt to the Host. The interrupt request and acknowledge sequence is shown in FIGURE B-4.

The sequence is as follows:

1. The M68360QUADS places a service request code on the parallel port data bus (buffer disabled) and asserts the ADS_INT and the HOST_BRK~ signals. The HOST_BRK~ signal is an open-collector signal, asserted low, common to all M68360QUADS boards which will appear immediately on the port. The ADS_INT signal will not appear on the port until the board is selected by the Host.
2. The Host detects the HOST_BRK~ signal and polls each M68360QUADS address to determine the interrupting board.
3. The Host asserts the HST_ACK signal, enabling the data buffer in the M68360QUADS.
4. The Host reads the service request code on the data bus.
5. The Host negates the HST_ACK signal.
6. The Host asserts the INT_ACK signal, which resets the HOST_BRK latch in the M68360QUADS and negates the HOST_BRK~ signal. the HOST_BRK~ signal can still be low (asserted) if another M68360QUADS board is driving it low.

7. The selected M68360QUADS detects the INT_ACK signal and negates the ADS_INT signal.
8. The Host negates the INT_ACK signal and ends the cycle.

FIGURE B-4 M68360QUADS Interrupt to Host

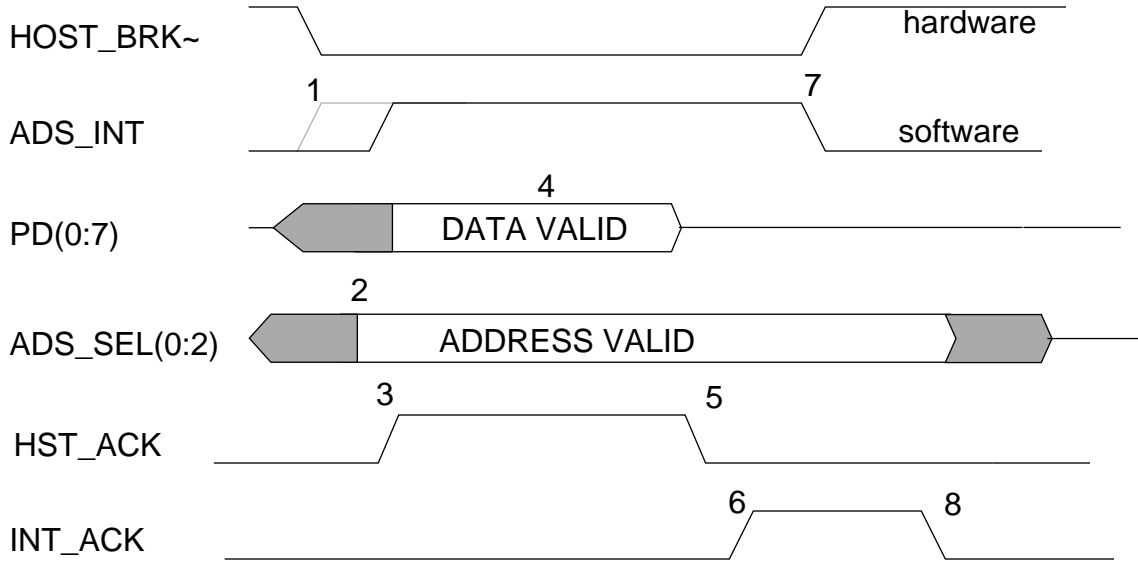

B.3.4 Host Interrupt to the M68360QUADS

The Host can interrupt the M68360QUADS (interrupt level 7) to abort the execution of programs running on the board. This is done by selecting the address of the required M68360QUADS and momentarily asserting the ADS_BRK signal, which sets a latch in the M68360QUADS. The output of the latch interrupts the master QUICC on the M68360QUADS. The latch is cleared by the interrupt handling software on the M68360QUADS.

B.3.5 Host Reset to the M68360QUADS

The Host can perform either hard reset or soft reset on the M68360QUADS. Soft reset is done by selecting the address of the required board and asserting the ADS_RESET signal for more than 26 microseconds. Hard reset is done by selecting the address of the required board, asserting INT_ACK signal, and asserting the ADS_RESET signal for more than 26 microseconds.

B.3.6 Addressing All M68360QUADS

The Host can reset or interrupt all M68360QUADS boards that are connected to the same ADI. The Host should assert the ADS_ALL signal in conjunction with either ADS_RESET or ADS_BRK. The contents of the ADS_SEL(0:2) lines have no affect.

APPENDIX C - PLDs DESCRIPTION

C.1 DATA BUS CONTROLLER - U51

The PLD chip U51 on schematic sheet 8 is a GAL22V10-7 device. This device generates the required byte enable signals according to the data bus width of the master QUICC, the accessed address, and the data size. The device also controls the operation of the data bus transceivers, and the data bus swapping.

module BUS_CNTL

title 'BUS CONTROL

AMIR YEHOShUA MOTOROLA SEMICONDUCTOR ISRAEL LTD. 12/12/92 '

U51 device 'P22V10';

RSTH~,AS~,DSK1~,A0,A1	pin 1,2,3,4,5 ;
SIZ0,SIZ1,A_DIR,B32_16~	pin 6,7,8,9 ;
S_CS7~,A28_31,R~	pin 10,11,13 ;
HI_EN~,SWAP~,LO_EN~,D_DIR	pin 14,15,16,17 ;
MDSK0~,SDSK0~	pin 18,19 ;
BE3~,BE2~,BE1~,BE0~	pin 20,21,22,23 ;
reset,preset	Node 25,26 ;

H,L,X,Z,C = 1,0,.X.,Z.,.C. ;

equations

reset = L ;
preset = L ;

ENABLE BE0~ = H ;

!BE0~ = !A0 & !A1 & !AS~
!R~ & !AS~ ;

ENABLE BE1~ = H ;

!BE1~ = !A1 & A0 & !AS~
!A1 & SIZ1 & !AS~
!A1 & !SIZ0 & !AS~
!R~ & !AS~ ;

ENABLE BE2~ = H ;

!BE2~ = A1 & !A0 & !AS~

```
# !A1 & !SIZ0 & !SIZ1 & !AS~ & !A_DIR
# !A1 & !SIZ0 & !SIZ1 & !AS~ & B32_16~
# !A1 & SIZ0 & SIZ1 & !AS~ & !A_DIR
# !A1 & SIZ0 & SIZ1 & !AS~ & B32_16~
# !A1 & A0 & !SIZ0 & !AS~ & !A_DIR
# !A1 & A0 & !SIZ0 & !AS~ & B32_16~
# !R~ & !AS~ ;
```

ENABLE BE3~ = H ;

!BE3~ = A0 & A1 & !AS~

```
# A1 & !A0 & SIZ1 & !AS~ & A_DIR & !B32_16~
# A1 & !A0 & !SIZ0 & !AS~ & A_DIR & !B32_16~
# A0 & SIZ0 & SIZ1 & !AS~ & !A_DIR
# A0 & SIZ0 & SIZ1 & !AS~ & B32_16~
# !SIZ0 & !SIZ1 & !AS~ & !A_DIR
# !SIZ0 & !SIZ1 & !AS~ & B32_16~
# A1 & SIZ1 & !AS~ & !A_DIR
# A1 & SIZ1 & !AS~ & B32_16~
# !R~ & !AS~ ;
```

ENABLE MDSK0~ = !SDSK0~ & A_DIR & RSTH~ ;

!MDSK0~ = !SDSK0~ & B32_16~ & !AS~

```
# !SDSK0~ & !B32_16~ & !AS~ & DSK1~ ;
```

ENABLE SDSK0~ = !MDSK0~ & !A_DIR & RSTH~ ;

!SDSK0~ = !MDSK0~ & B32_16~ & !AS~

```
# !MDSK0~ & !B32_16~ & !AS~ & DSK1~ ;
```

ENABLE D_DIR = H ;

!D_DIR = !R~ & S_CS7~ & !A28_31

```
# !A_DIR & R~ ;
```

ENABLE LO_EN~ = H ;

!LO_EN~ = B32_16~ & !AS~ & RSTH~ ;

ENABLE SWAP~ = H ;

```
!SWAP~ = !B32_16~ & !AS~ & RSTH~ & A_DIR & R~
# !B32_16~ & !AS~ & RSTH~ & A_DIR & S_CS7~
& !A28_31 & A1 & !DSK1~ & !SDSK0~
# !B32_16~ & !AS~ & RSTH~ & A_DIR & S_CS7~
& !A28_31 & A1 & !DSK1~ & !MDSK0~ ;
```

ENABLE HI_EN~ = H ;

```
!HI_EN~ = B32_16~ & !AS~ & RSTH~
# !B32_16~ & !AS~ & RSTH~ & !A_DIR
# !B32_16~ & !AS~ & RSTH~ & A_DIR & R~
# !B32_16~ & !AS~ & RSTH~ & A_DIR & S_CS7~
& !A28_31 & !A1
# !B32_16~ & !AS~ & RSTH~ & A_DIR & S_CS7~
& !A28_31 & A1 & !DSK1~ & SDSK0~ & MDSK0~
# !B32_16~ & !AS~ & RSTH~ & A_DIR & S_CS7~
& !A28_31 & A1 & DSK1~ & !SDSK0~
# !B32_16~ & !AS~ & RSTH~ & A_DIR & S_CS7~
& !A28_31 & A1 & DSK1~ & !MDSK0~ ;
```

end BUS_CNTL

C.2 BUS ARBITER - U42

The PLD chip U42 on schematic sheet 9 is a PAL16R4-7 device. This device uses the master QUICC arbitration logic to transfer the bus mastership to the slave QUICC or to external master.

The Bus Grant signals to the slave QUICC and to the external master are asserted after the BGACK~ signal is negated. This is to ensure that the address bus transceivers are opened correctly before the requesting master takes control of the bus.

This device also generates the signal A28_31 which is used by the Data Bus Controller to determine if the current access is to a device on the QUADS board.

module ARBITER

title 'BUS ARBITER

AMIR YEHOShUA MOTOROLA SEMICONDUCTOR ISRAEL LTD. 18/3/93 '

U42 device 'P16R4';

SCLKO1,OC~	pin 1,11 ;
EXTBR~,M_BG~,S_BR~,BGACK~	pin 2,3,4,5 ;
A28,A29,A30,A31,M_CS0~,E_CS~	pin 6,7,8,9,12,13 ;
M_BR~,EXTBG~,S_BG~,A_DIR,NC,A28_31	pin 14,15,16,17,18,19 ;

H,L,X,Z,C = 1,0,.X.,.Z.,.C.;

equations

!A_DIR := !S_BG~
!BGACK~ & !A_DIR ;

!M_BR~ := !EXTBR~ # !S_BR~ ;

!EXTBG~ := EXTBG~ & S_BR~ & !M_BR~ & S_BG~ & !M_BG~ & BGACK~
!EXTBG~ & !EXTBR~ & S_BG~ & !M_BG~ ;

!S_BG~ := S_BG~ & !S_BR~ & !M_BR~ & EXTBG~ & !M_BG~ & BGACK~
!S_BG~ & !S_BR~ & EXTBG~ & !M_BG~ ;

ENABLE M_CS0~ = L ;

ENABLE E_CS~ = L ;

ENABLE NC = H ;

ENABLE A28_31 = H ;

NC = H ;

```
!A28_31 = !A28 & !A29 & !A30 & !A31 & M_CS0~  
# !A28 & !A29 & !A30 & !A31 & !E_CS~  
# A28 & A29 & A30 & A31 & M_CS0~  
# A28 & A29 & A30 & A31 & !E_CS~ ;
```

```
end ARBITER
```

C.3 ADI PORT CONTROLLER - U43

The PLD chip U43 on schematic sheet 12 is a PAL22V10-25 device used for controlling the ADI port.

module ADI

title 'ADI

AMIR YEHOASHUA MOTOROLA SEMICONDUCTOR ISRAEL LTD. 12/12/92 '

U43 device 'P22V10';

ADS_G~,RSTS~,HSVCC~,ADRST~	pin 1,2,3,4 ;
ADALL~,ADBRK~,HSTEN,HSACK~	pin 5,6,7,8 ;
HSREQ~,INACK~,ADSSEL	pin 9,10,13 ;
ADIRD~,CK_NMI,BKCLR~	pin 14,15,16 ;
ADIAC~	pin 19 ;
H_RSTH,H_RSTS,ADI_G~,ADIDIR	pin 20,21,22,23 ;
reset,preset	Node 25,26 ;

H,L,X,Z,C = 1,0,.X.,Z.,.C. ;

equations

```

reset = L ;
preset = L ;
ENABLE ADIDIR = H ;
ENABLE ADI_G~ = H ;
ENABLE H_RSTS = H ;
ENABLE H_RSTH = H ;
ENABLE ADIAC~ = H ;
ENABLE CK_NMI = H ;
ENABLE BKCLR~ = H ;
ENABLE ADIRD~ = H ;

```

```

H_RSTS = HSTEN & !HSVCC~ & !ADRST~ & ADSSEL
# HSTEN & !HSVCC~ & !ADRST~ & !ADALL~ ;

```

```

H_RSTH = HSTEN & !HSVCC~ & !ADRST~ & ADSSEL & !INACK~
# HSTEN & !HSVCC~ & !ADRST~ & !ADALL~ & !INACK~ ;

```

```

CK_NMI = HSTEN & !HSVCC~ & !ADBRK~ & ADSSEL
# HSTEN & !HSVCC~ & !ADBRK~ & !ADALL~ ;

```

```

!BKCLR~ = !RSTS~
    # !INACK~ & HSTEN & !HSVCC~ & ADSSEL ;

!ADIRD~ = HSTEN & ADSSEL & !HSVCC~ ;

!ADI_G~ = !HSTEN
    # !HSVCC~ & (ADSSEL # !ADALL~)
    & (!HSACK~ # !ADS_G~) ;

!ADIAC~ = HSTEN & !HSVCC~ & !HSREQ~ & !ADALL~
    # HSTEN & !HSVCC~ & !HSREQ~ & ADSSEL
    # HSTEN & !HSVCC~ & !HSACK~ & ADSSEL ;

!ADIDIR = !HSTEN # ADS_G~ # (ADSSEL & !HSACK~) ;

```

end ADI

C.4 Disable CPU Configuration for Slave QUICC - SP1

The PLD chip SP1 on schematic sheet 15 is a PAL22V10-25 device that operates during hard reset and it is used to configure the slave QUICC in disable CPU operation mode.

To disable the CPU in the QUICC device, the encoding of its configuration pins must **enable** the CPU for more than 32 clocks during hard reset, and then they must be encoded according to the required operation mode before the hard reset signal is negated (high level). The PLD device drives configuration pin 0 of the slave QUICC to high level for 64 clocks, and then the signal CONF2 drives it to low level as long as the hard reset signal is asserted (low level). When the hard reset signal is negated, the CONF2 is in three-state and it stops driving the configuration pin 0.

```

TITLE DISCPU
PATTERN dis_cpu.pds
Revision A
AUTHOR Yair Liebman
COMPANY MOTOROLA SEMICONDUCTOR ISRAEL LTD
DATE 14/3/93

CHIP DIS_CPU PAL22V10
;*****

CLK NC NC NC NC NC NC NC CIN NC RESETH GND
;I1 I2 I3 I4 I5 I6 I7 I8 I9 I10 I11 I12

NC Q5 Q4 Q3 Q2 Q1 Q0 CONF2 S_RST DD_RST D_RST VCC
;I13 O14 O15 O16 O17 O18 O19 O20 O21 O22 O23 24

GLOBAL

EQUATIONS

D_RST := RESETH

D_RST.TRST = VCC

DD_RST := D_RST

DD_RST.TRST = VCC

/S_RST = /D_RST * DD_RST

Q0 := /Q0 * S_RST * CIN
      + Q0 * S_RST * /CIN

Q0.TRST = VCC

```

$$\begin{aligned} Q1 &:= /Q1 * Q0 * S_RST * CIN \\ &+ Q1 * /Q0 * S_RST * CIN \\ &+ Q1 * S_RST * /CIN \end{aligned}$$

$$Q1.TRST = VCC$$

$$\begin{aligned} Q2 &:= Q2 * /Q1 * S_RST * CIN \\ &+ Q2 * /Q0 * S_RST * CIN \\ &+ /Q2 * Q1 * Q0 * S_RST * CIN \\ &+ Q2 * S_RST * /CIN \end{aligned}$$

$$Q2.TRST = VCC$$

$$\begin{aligned} Q3 &:= Q3 * /Q2 * S_RST * CIN \\ &+ Q3 * /Q1 * S_RST * CIN \\ &+ Q3 * /Q0 * S_RST * CIN \\ &+ /Q3 * Q2 * Q1 * Q0 * S_RST * CIN \\ &+ Q3 * S_RST * /CIN \end{aligned}$$

$$Q3.TRST = VCC$$

$$\begin{aligned} Q4 &:= Q4 * /Q3 * S_RST * CIN \\ &+ Q4 * /Q2 * S_RST * CIN \\ &+ Q4 * /Q1 * S_RST * CIN \\ &+ Q4 * /Q0 * S_RST * CIN \\ &+ /Q4 * Q3 * Q2 * Q1 * Q0 * S_RST * CIN \\ &+ Q4 * S_RST * /CIN \end{aligned}$$

$$Q4.TRST = VCC$$

$$\begin{aligned} Q5 &:= Q5 * /Q4 * S_RST * CIN \\ &+ Q5 * /Q3 * S_RST * CIN \\ &+ Q5 * /Q2 * S_RST * CIN \\ &+ Q5 * /Q1 * S_RST * CIN \\ &+ Q5 * /Q0 * S_RST * CIN \\ &+ /Q5 * Q4 * Q3 * Q2 * Q1 * Q0 * S_RST * CIN \\ &+ Q5 * S_RST * /CIN \end{aligned}$$

$$Q5.TRST = VCC$$



$\text{/CONF2} = \text{Q0} * \text{Q1} * \text{Q2} * \text{Q3} * \text{Q4} * \text{Q5}$

$\text{CONF2.TRST} = \text{/RESETH}$

$\text{GLOBAL.SETF} = \text{GND}$

$\text{GLOBAL.RSTF} = \text{GND}$

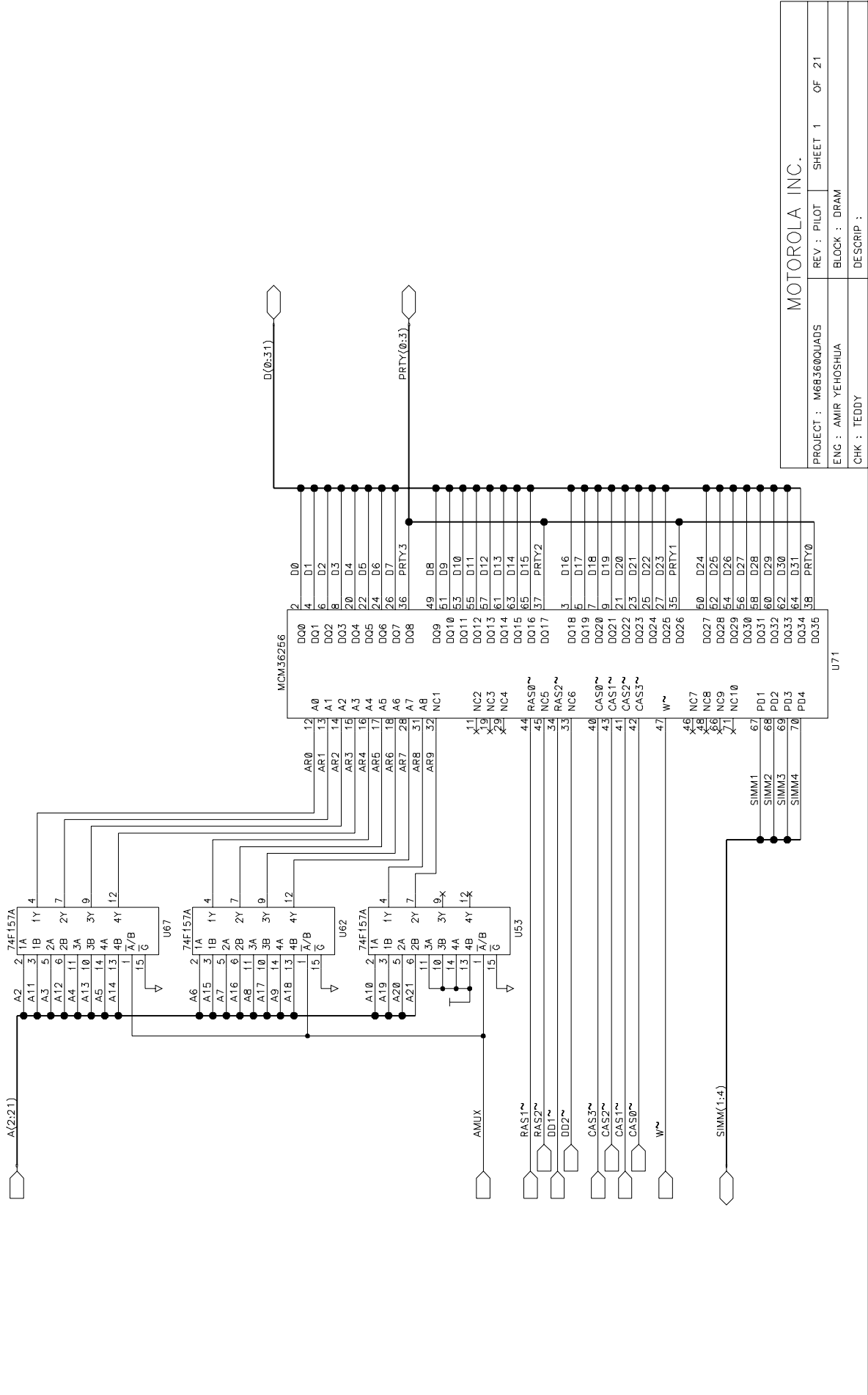

PROJECT : M6B360QUADS	
REV : PILOT	
SHEET 1 OF 21	
ENG : AMIR YEHOSHUA	
BLOCK : DRAM	
CHK : TEDDY	
DESCRIP :	
MOTOROLA INC.	

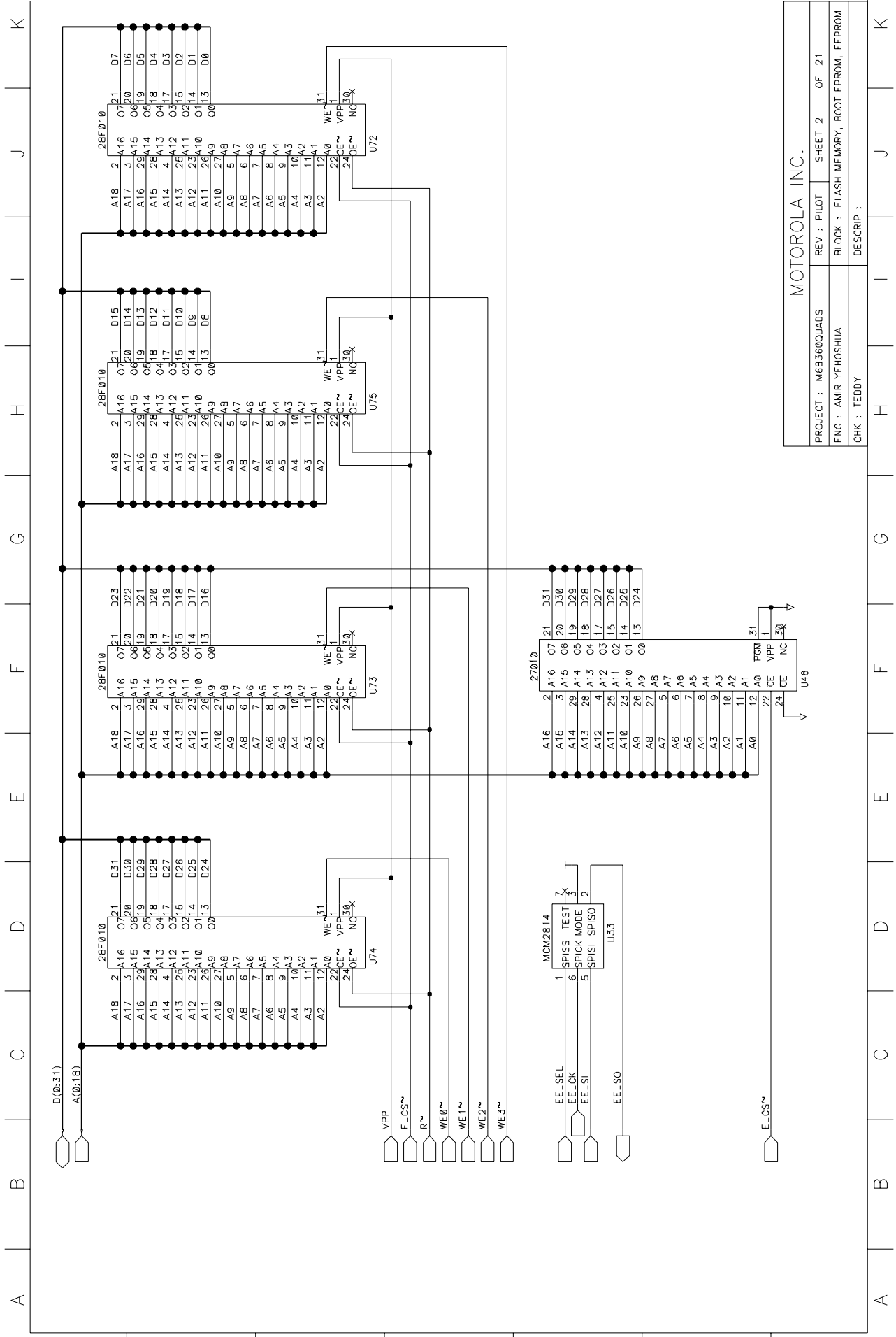

MOTOROLA INC.			
PROJECT : M6B360QUADS	REV : PILOT	SHEET 2	OF 21
ENG : AMIR YEHOSHUA	BLOCK : FLASH MEMORY, BOOT EPROM, EPROM		
CHK : TEDDY	DESCRIP :		

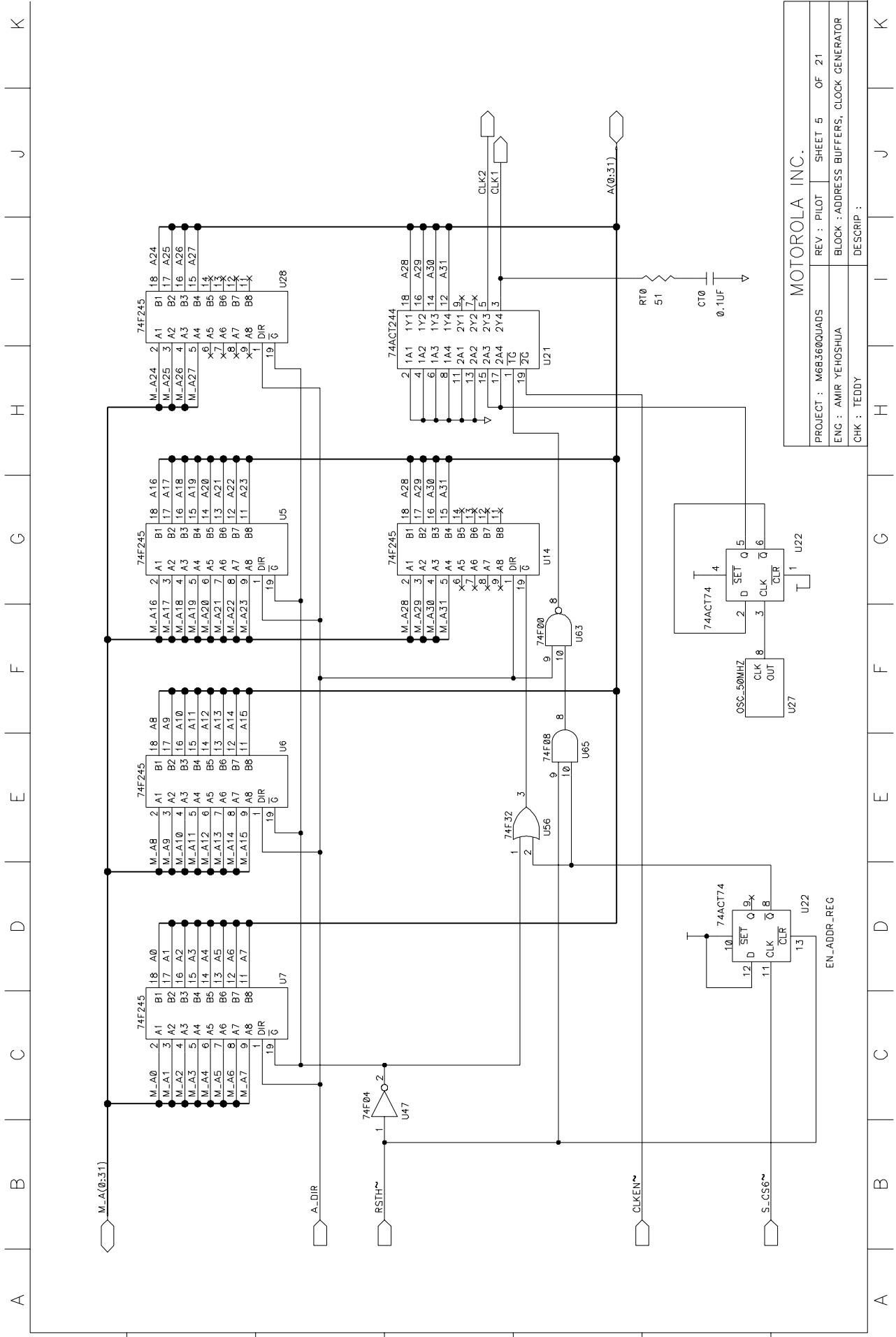

MOTOROLA INC.			
PROJECT : M68360QUADS	REV : PILOT	SHEET 5	OF 21
ENG : AMIR YEHOOSHUA	BLOCK : ADDRESS BUFFERS, CLOCK GENERATOR		
CHK : TEDDY	DESCRIP :		

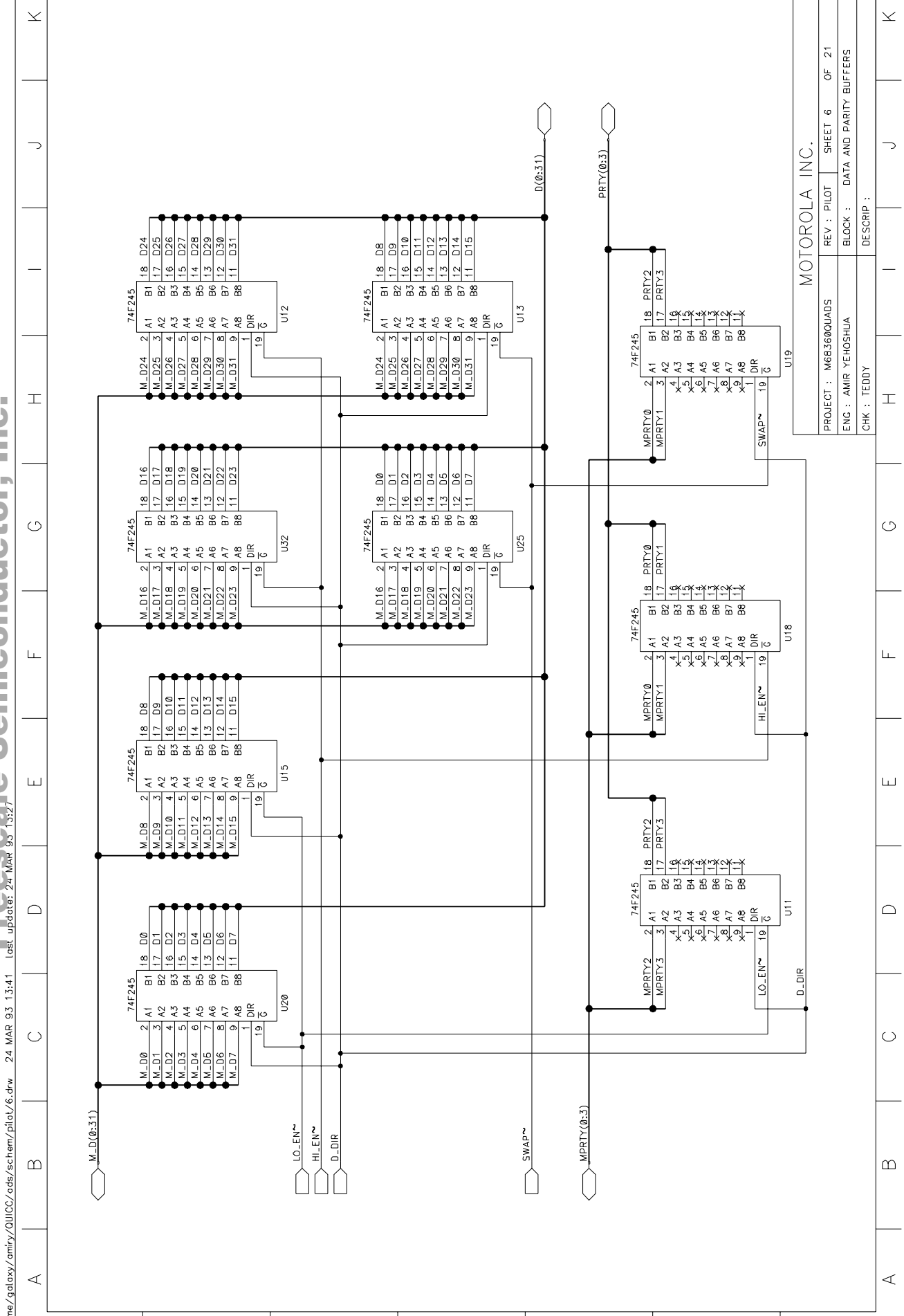

MOTOROLA INC.		
PROJECT : M68360QUADS	REV : PILOT	SHEET 6 OF 21
ENG : AMIR YEHOSHUA	BLOCK : DATA AND PARITY BUFFERS	
CHK : TEDDY	DESCRIP :	

/home/galaxy/amiry/QUICC/ods/schem/pilot/6.drw 24 MAR 93 13:41 lost update: 24 MAR 93 13:27

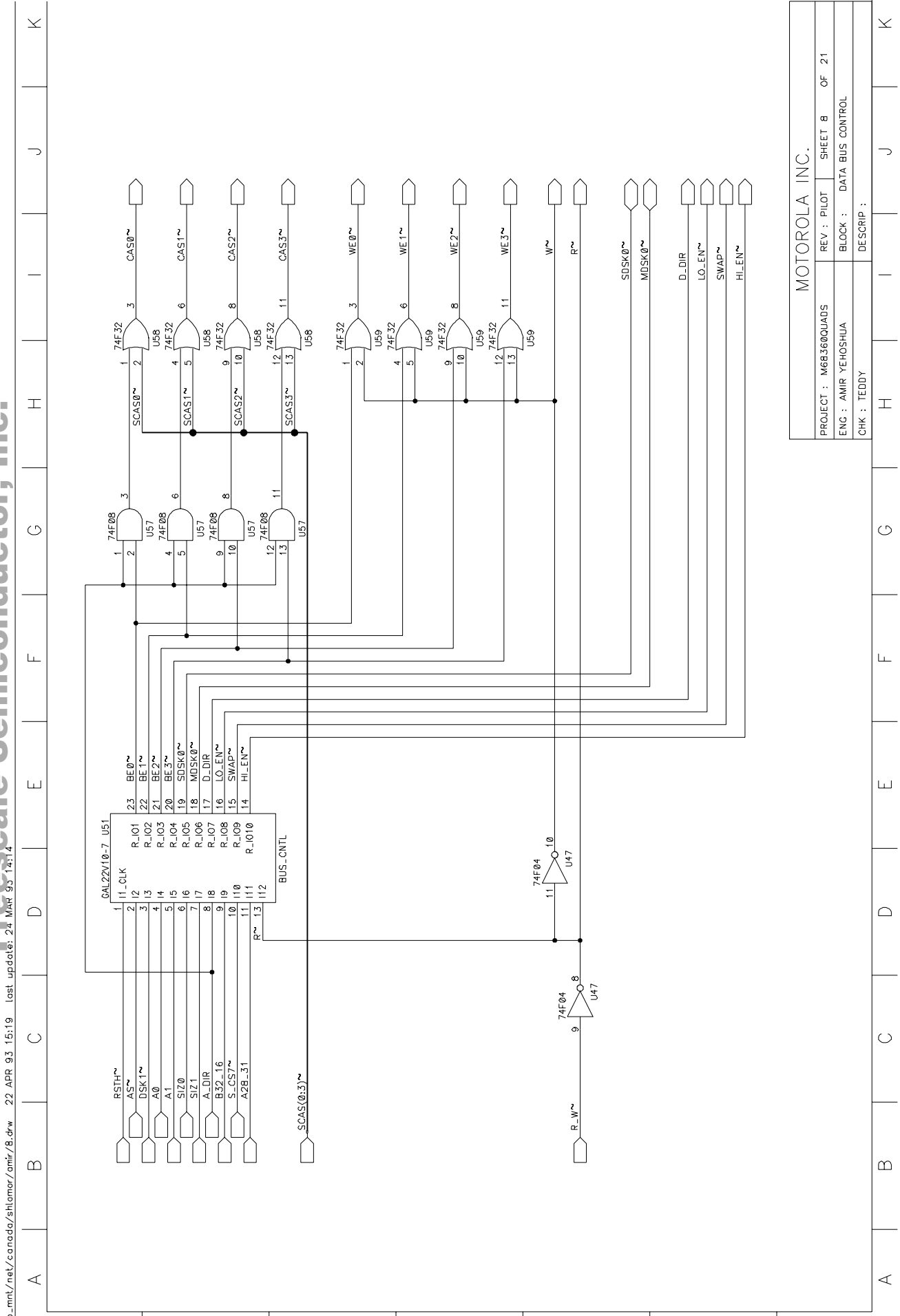

MOTOROLA INC.		
PROJECT : M68360QUADS	REV : PILOT	SHEET 8 OF 21
ENG : AMIR YEHOSHUA	BLOCK : DATA BUS CONTROL	
CHK : TEDDY	DESCRIP :	

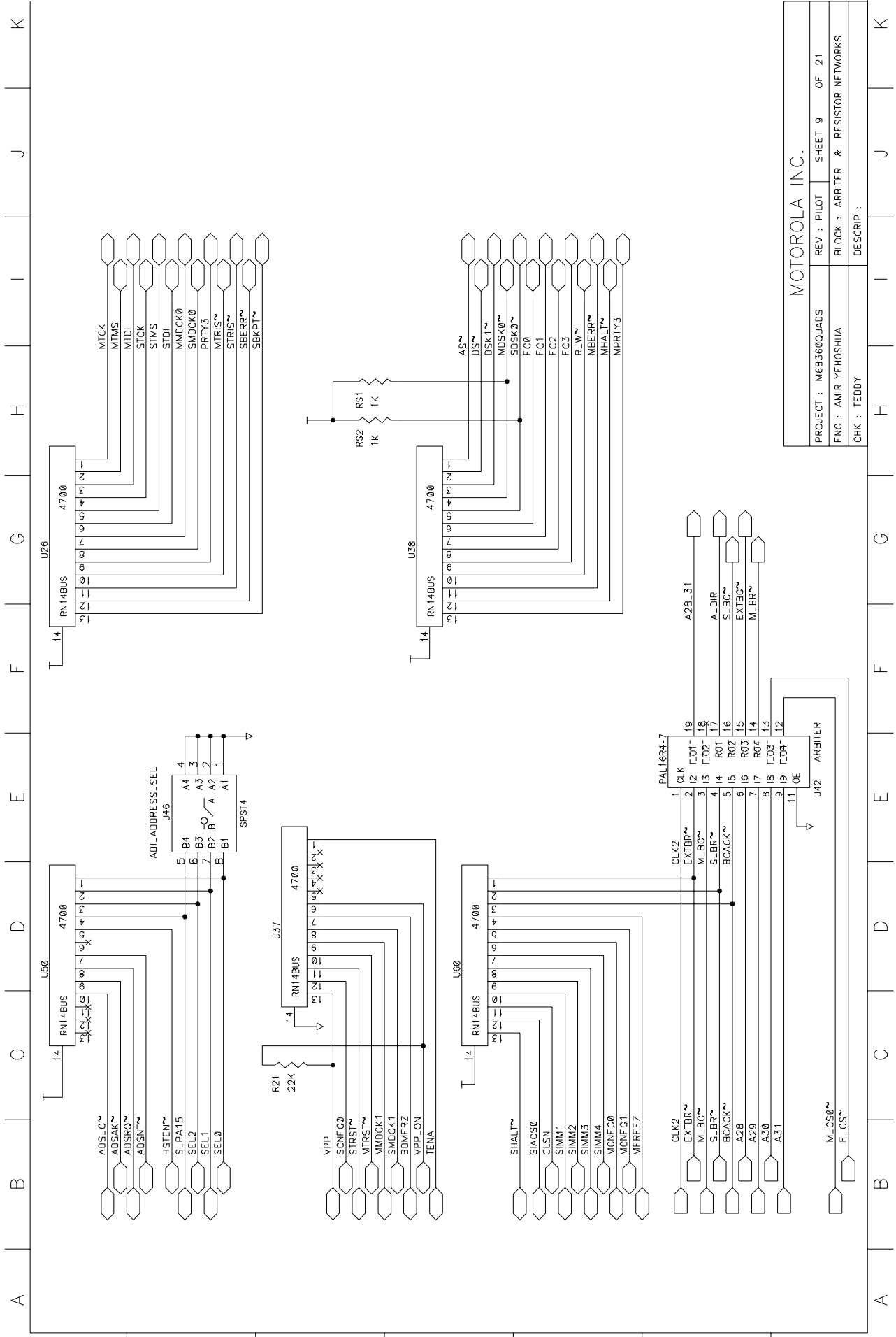

MOTOROLA INC.

PROJECT : M6B360QUADS	REV : PILOT	SHEET 9	OF 21
ENG : AMIR YEHOSHUA	BLOCK : ARBITER & RESISTOR NETWORKS		
CHK : TEDDY	DESCRIP :		

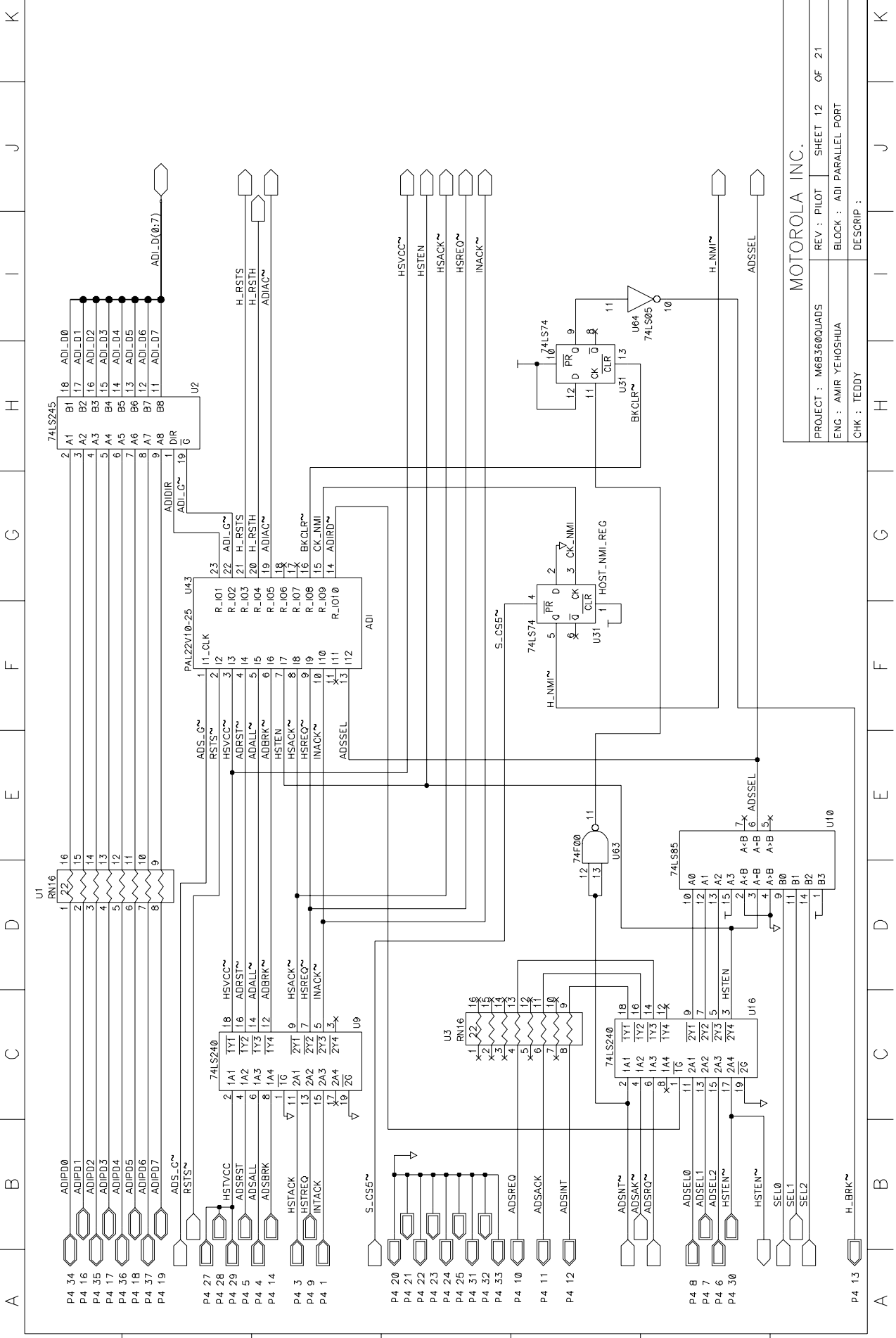

MOTOROLA INC.

PROJECT : M68360QUADS	REV : PILOT	SHEET 12	OF 21
ENG : AMIR YEHOSHUA	BLOCK : ADI PARALLEL PORT		
CHK : TEDDY	DESCRIP :		

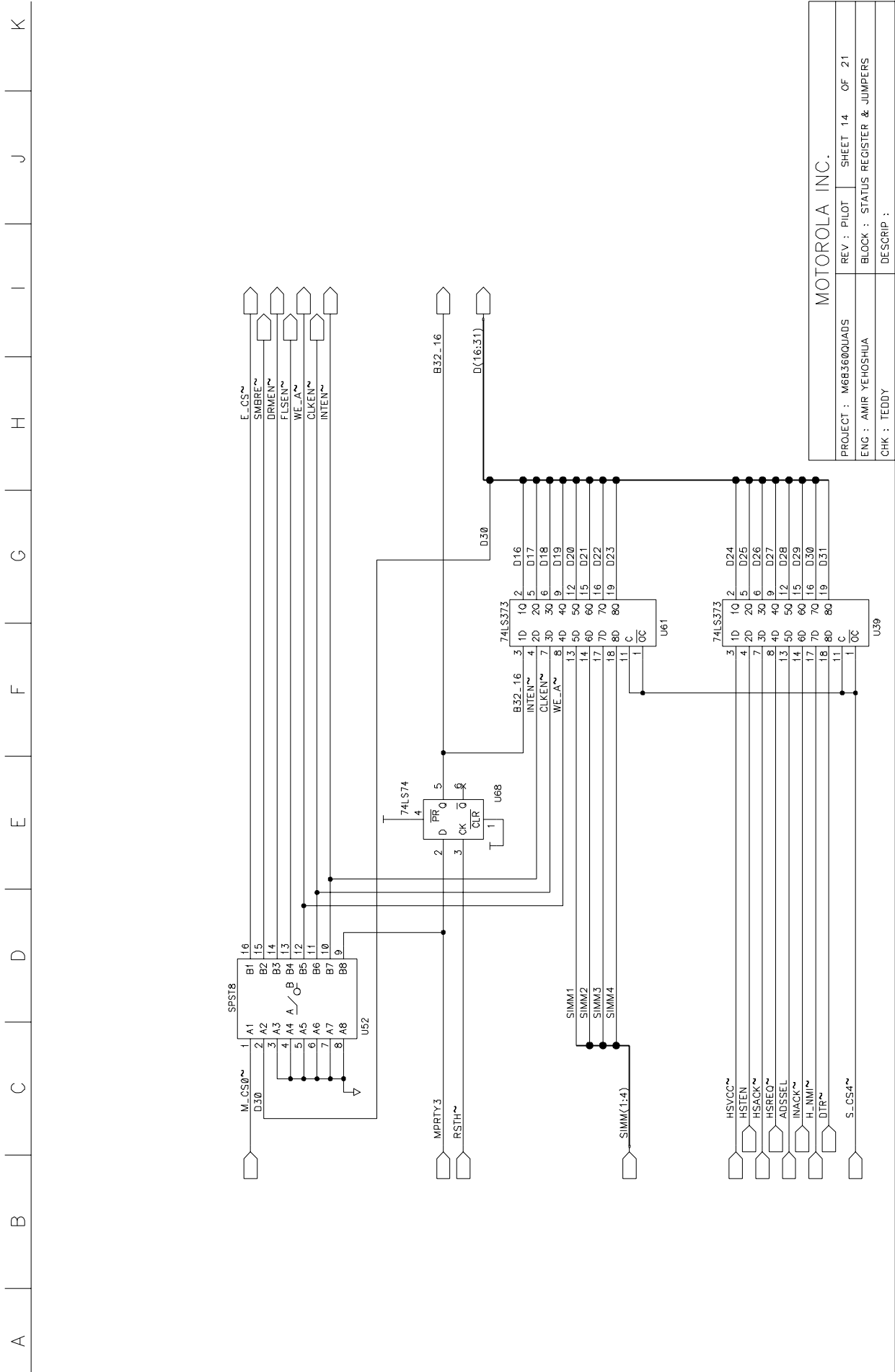

MOTOROLA INC.			
PROJECT : M6B360QUADS	REV : PILOT	SHEET 14	OF 21
ENG : AMIR YEHOSHUA	BLOCK : STATUS REGISTER & JUMPERS		
CHK : TEDDY	DESCRIP :		

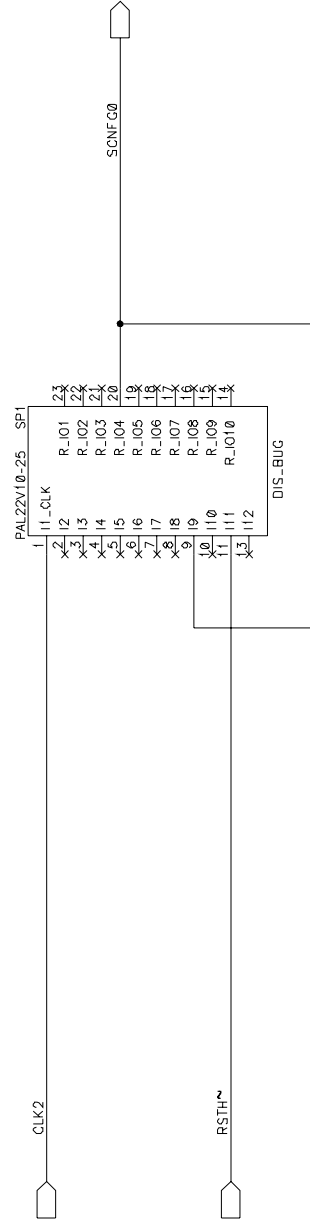
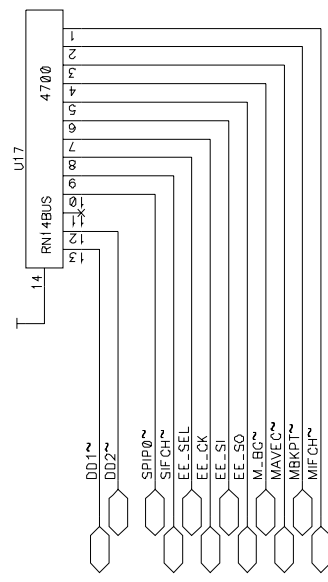
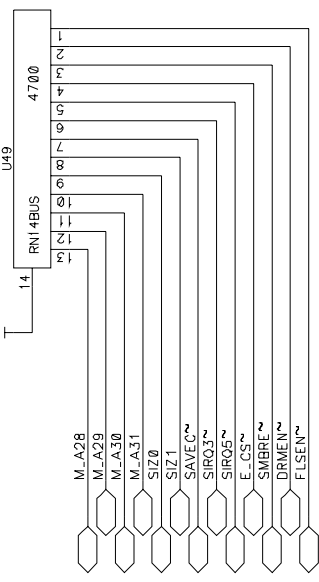
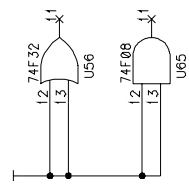

MOTOROLA INC.			
PROJECT : M6B360QUADS	REV : PILOT	SHEET 15	OF 21
ENG : AMIR YEHOSHUA	BLOCK : PULL-UP RESISTORS and SPARES		
CHK : TEDDY	DESCRIP :		



A B C D E F G H I J K

1

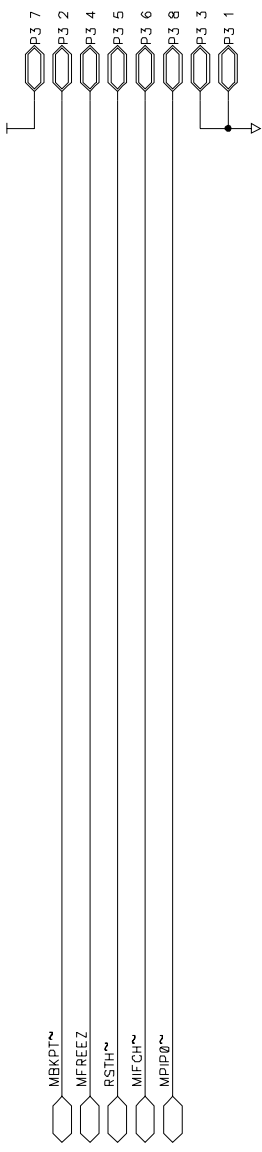

2

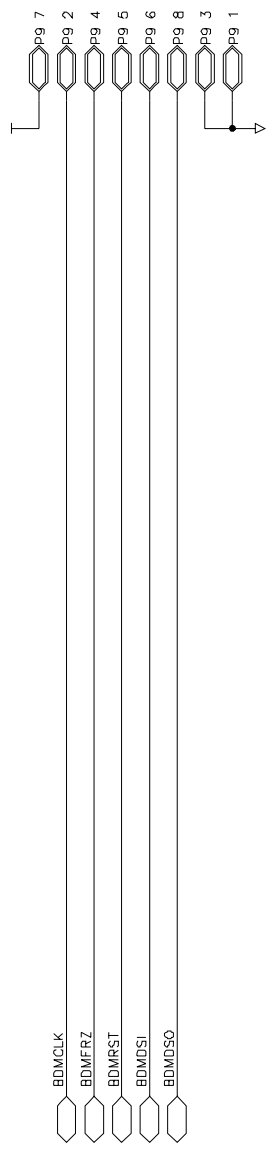

3

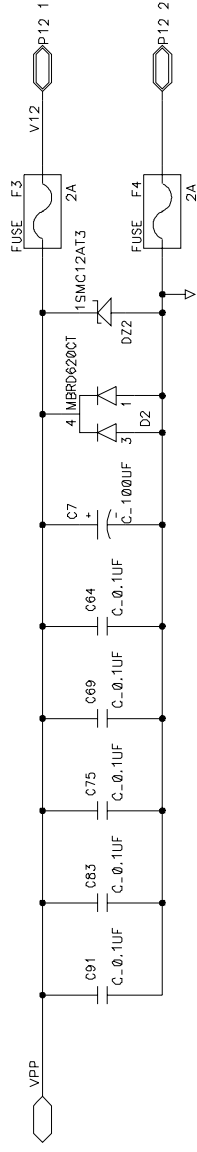

5

7

MOTOROLA INC.			
PROJECT : M6B360QUADS	REV : PILOT	SHEET 16	OF 21
ENG : AMIR YEHOSHUA	BLOCK : DBM CONNECTORS AND 12V SUPPLY		
CHK : TEDDY	DESCRIP :		

A B C D E F G H I J K

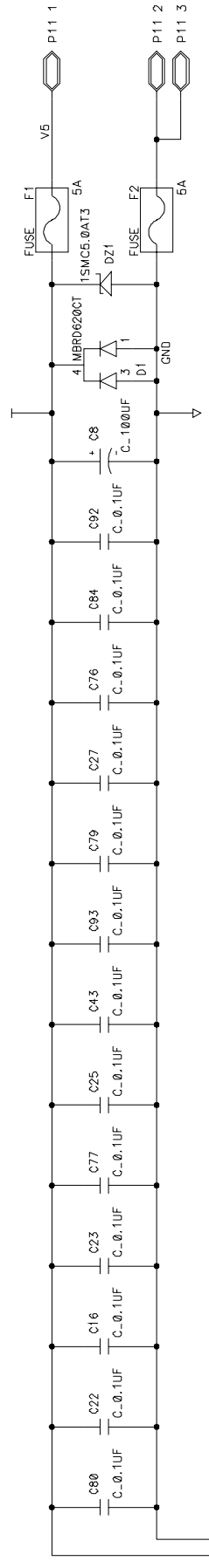

MOTOROLA INC.			
PROJECT : M6B360QUADS	REV : PILOT	SHEET 17	OF 21
ENG : AMIR YEHOSHUA	BLOCK : 5v POWER SUPPLY		
CHK : TEDDY	DESCRIP :		

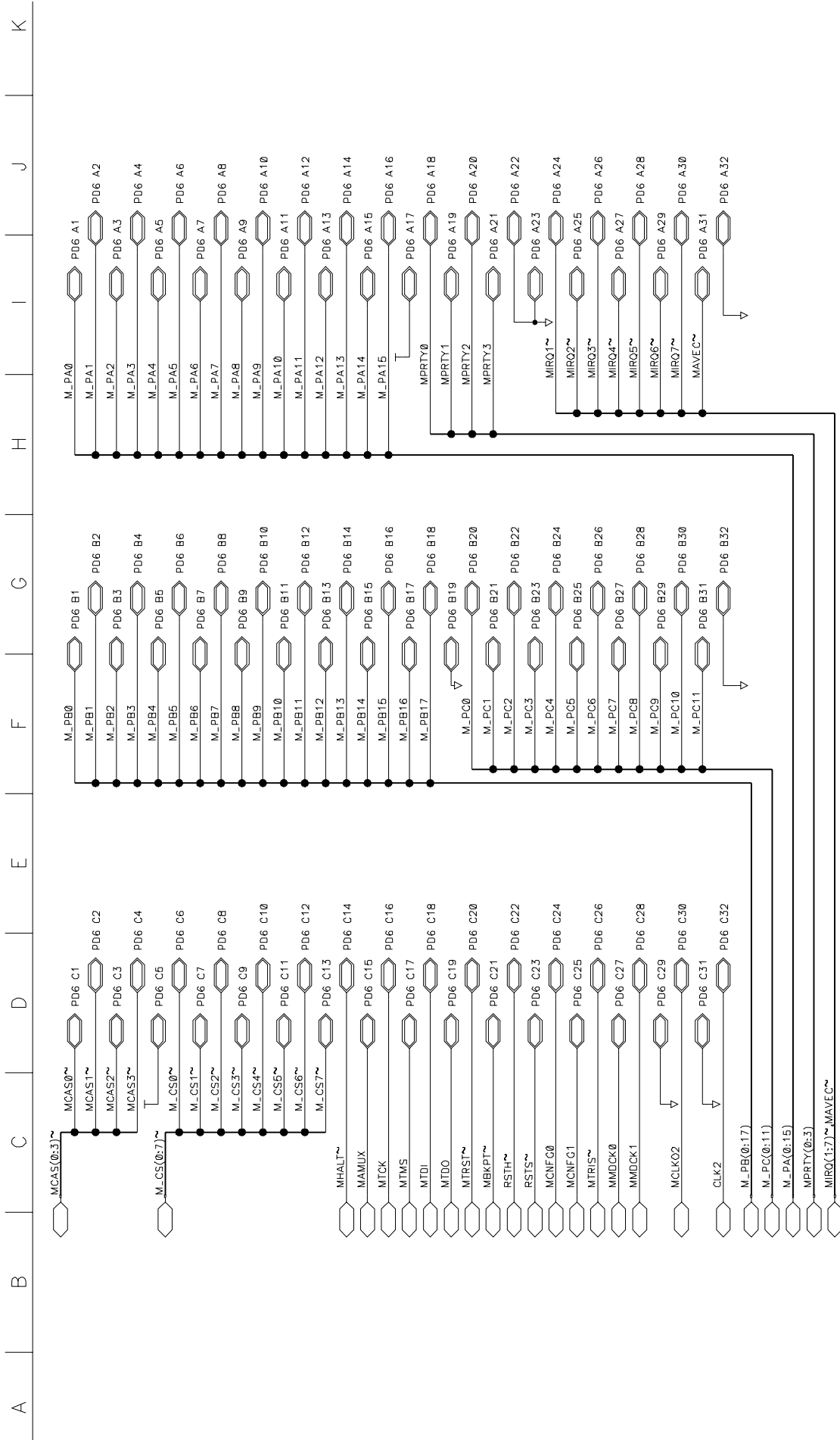

MOTOROLA INC.			
PROJECT : M68360QUADS	REV : PILOT	SHEET 19	OF 21
ENG : AMIR YEHOSHUA	BLOCK : 96 PIN LOGIC ANALYZER CONNECTOR		
CHK : TEDDY	DESCRIP :		

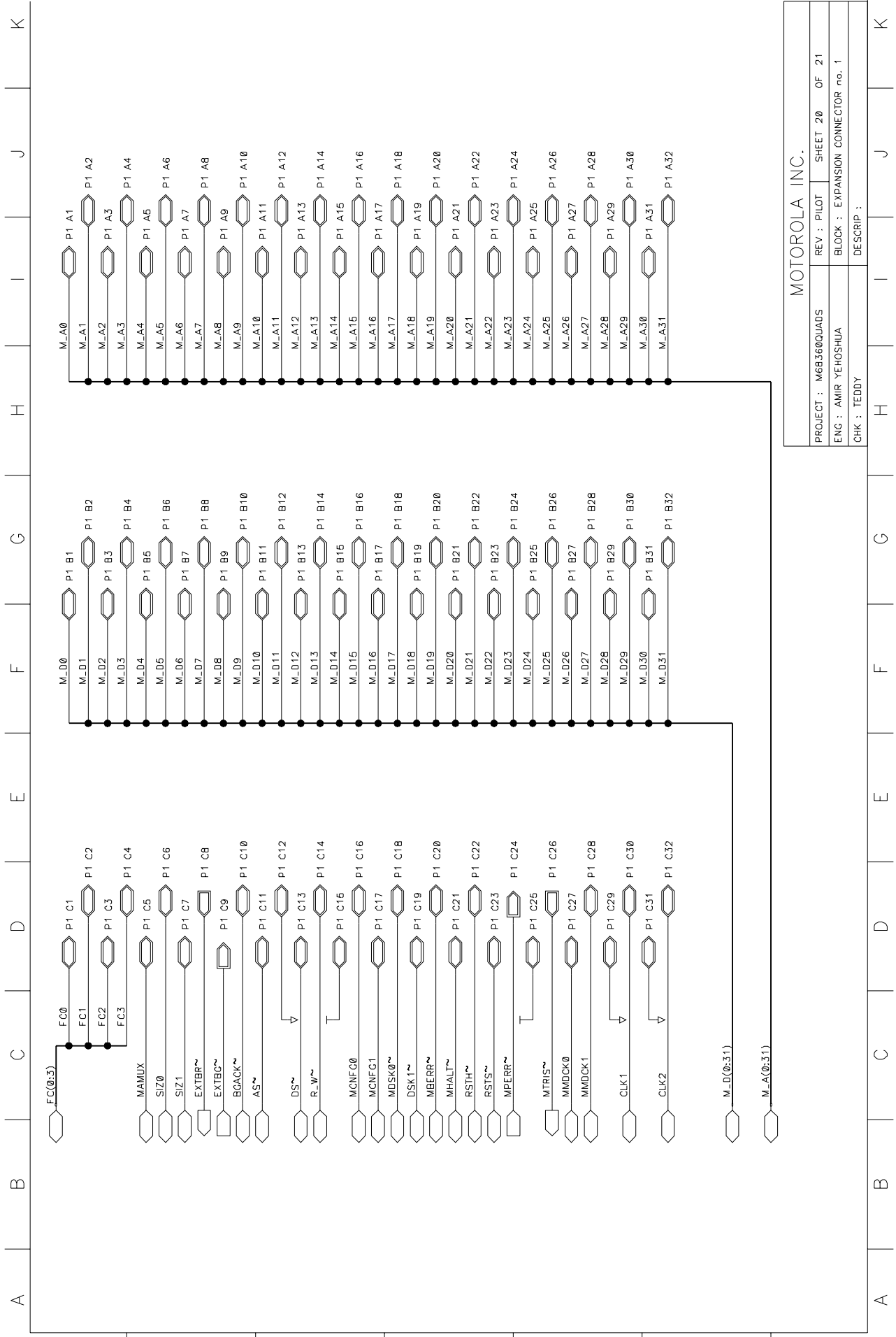

MOTOROLA INC.

PROJECT : M6B360QUADS	REV : PILOT	SHEET 20	OF 21
ENG : AMIR YEHOShUA	BLOCK : EXPANSION CONNECTOR no. 1		
CHK : TEDDY	DESCRIP :		

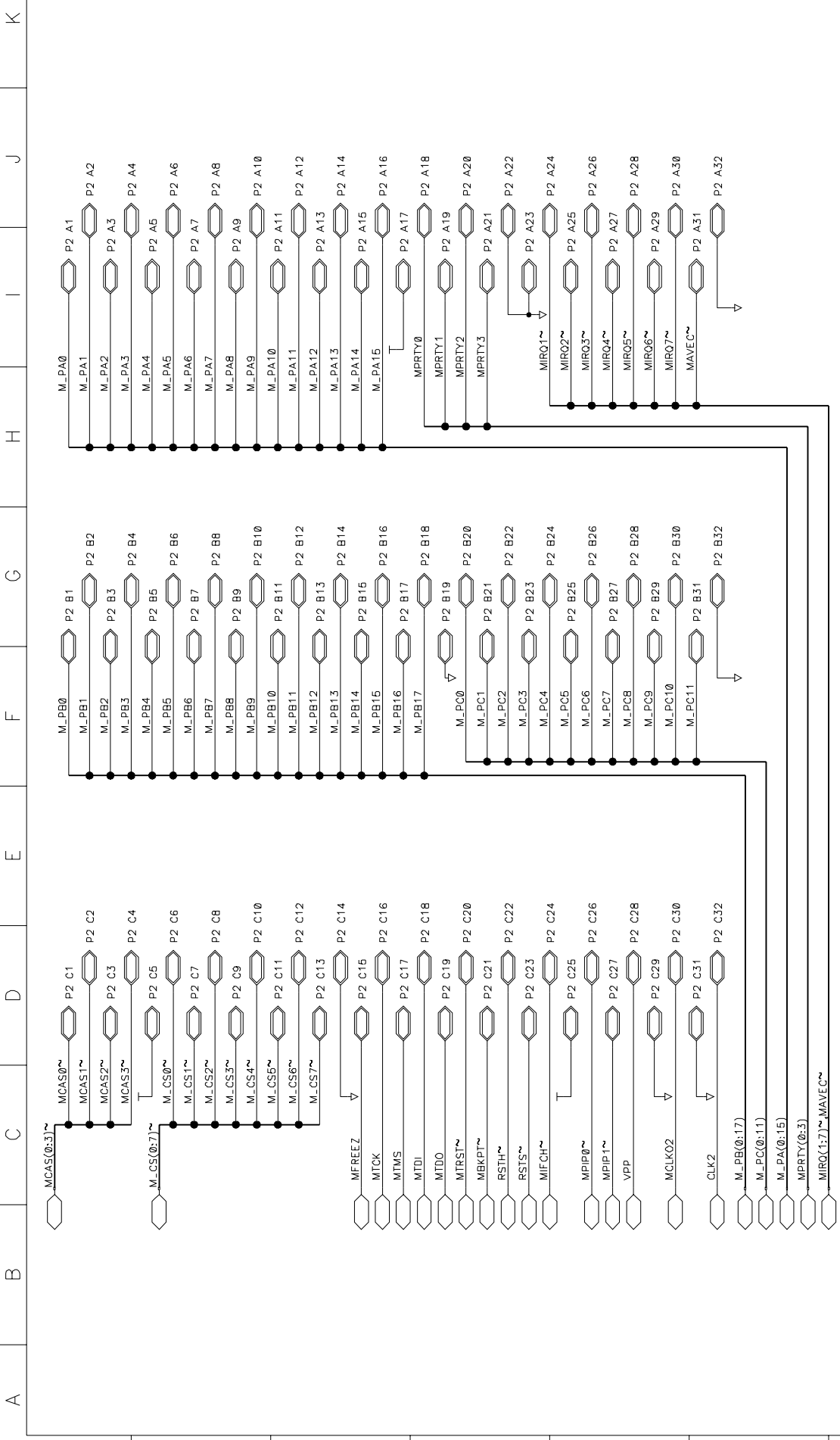

MOTOROLA INC.		
PROJECT : M6B360QUADS	REV : PILOT	SHEET 21 OF 21
ENG : AMIR YEHOOSHUA	BLOCK : EXPANSION CONNECTOR no. 2	
CHK : TEDDY	DESCRIP :	