

# TWR-SB0410-36EVB tower system platform

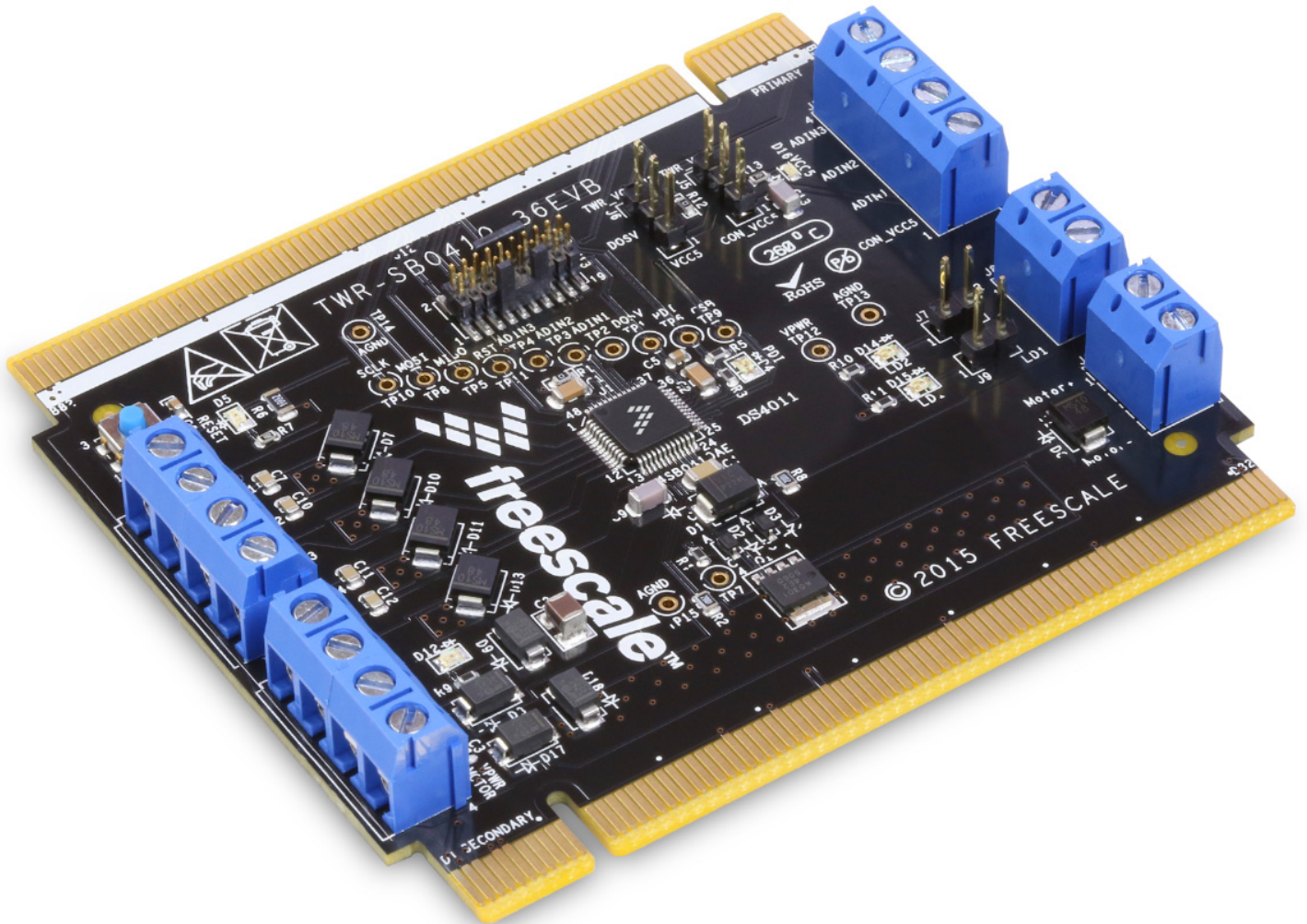

Figure 1. TWR-SB0410-36EVB

# Contents

1	Important notice	3
2	Getting started	4
3	Understanding the tower system modular development board platform	5
4	Getting to know the hardware	7
5	Setting Up the hardware	14
6	Schematics	16
7	Board layout	19
8	Board bill of materials	20
9	References	22
10	Revision history	24

# 1 Important notice

NXP provides the enclosed product(s) under the following conditions:

This evaluation kit is intended for use of ENGINEERING DEVELOPMENT OR EVALUATION PURPOSES ONLY. It is provided as a sample IC pre-soldered to a printed circuit board to make it easier to access inputs, outputs, and supply terminals. This evaluation board may be used with any development system or other source of I/O signals by simply connecting it to the host MCU or computer board via off-the-shelf cables. This evaluation board is not a Reference Design and is not intended to represent a final design recommendation for any particular application. Final device in an application will be heavily dependent on proper printed circuit board layout and heat sinking design as well as attention to supply filtering, transient suppression, and I/O signal quality.

The goods provided may not be complete in terms of required design, marketing, and or manufacturing related protective considerations, including product safety measures typically found in the end product incorporating the goods. Due to the open construction of the product, it is the user's responsibility to take any and all appropriate precautions with regard to electrostatic discharge. In order to minimize risks associated with the customers applications, adequate design and operating safeguards must be provided by the customer to minimize inherent or procedural hazards. For any safety concerns, contact NXP sales and technical support services.

Should this evaluation kit not meet the specifications indicated in the kit, it may be returned within 30 days from the date of delivery and will be replaced by a new kit.

NXP reserves the right to make changes without further notice to any products herein. NXP makes no warranty, representation or guarantee regarding the suitability of its products for any particular purpose, nor does NXP assume any liability arising out of the application or use of any product or circuit, and specifically disclaims any and all liability, including without limitation consequential or incidental damages. "Typical" parameters can and do vary in different applications and actual performance may vary over time. All operating parameters, including "Typical", must be validated for each customer application by customer's technical experts.

NXP does not convey any license under its patent rights nor the rights of others. NXP products are not designed, intended, or authorized for use as components in systems intended for surgical implant into the body, or other applications intended to support or sustain life, or for any other application in which the failure of the NXP product could create a situation where personal injury or death may occur.

Should the Buyer purchase or use NXP products for any such unintended or unauthorized application, the Buyer shall indemnify and hold NXP and its officers, employees, subsidiaries, affiliates, and distributors harmless against all claims, costs, damages, and expenses, and reasonable attorney fees arising out of, directly or indirectly, any claim of personal injury or death associated with such unintended or unauthorized use, even if such claim alleges NXP was negligent regarding the design or manufacture of the part. NXP™ and the NXP logo are trademarks of NXP Semiconductors. All other product or service names are the property of their respective owners. © 2016 NXP B.V.

## 2 Getting started

### 2.1 Kit contents/packing list

The TWR-SB0410-36EVB contents include:

- TWR-SB0410-36EVB tower board
- Plug-in connectors
- Warranty card

### 2.2 Jump start

NXP's analog product development boards help to easily evaluate NXP products. These tools support analog mixed signal and power solutions including monolithic ICs using proven high-volume SMARTMOS mixed signal technology, and system-in-package devices utilizing power, SMARTMOS and MCU dies. NXP products enable longer battery life, smaller form factor, component count reduction, ease of design, lower system cost, and improved performance in powering state of the art systems.

- Go to [www.nxp.com/TWR-SB0410-36EVB](http://www.nxp.com/TWR-SB0410-36EVB)
- Review the tool summary page
- Look for



#### Jump Start Your Design

- Download documents, software, and other information

Once the files are downloaded, review the user guide in the bundle. The user guide includes setup instructions, BOM, and schematics. Jump start bundles are available on each tool summary page with the most relevant and current information. The information includes everything needed for design.

### 2.3 Required equipment and software

To use this kit, you need:

- Power supply 6.0 V to 36 V with current limit set initially to 2.25 A to 9.0 A
- Oscilloscope (preferably 4-channel) with current probe(s) (optional)
- Digital multimeter
- Typical loads (DC motor, valve)
- TWR-KL25Z48M or K20D72M or KV31F120M or other Tower boards (check compatibility)
- Kinetis Design Studio or compatible CodeWarrior for MCUs (Eclipse IDE). For information on getting started with CodeWarrior, see the MC34ValveController Processor Expert Component User Guide.

### 2.4 System requirements

The kit requires the following to function properly with the software:

- USB-enabled PC with Windows® XP or higher

### 3 Understanding the tower system modular development board platform

NXP's Tower System peripheral module is designed to be combined and used with other Tower System modules. The Tower System is a modular development platform for 8-, 16-, and 32-bit MCUs and MPUs enabling advanced development through rapid prototyping. Featuring more than fifty development boards or modules, the Tower System provides designers with building blocks for entry-level to advanced MCU development. [Figure 2](#) shows a Tower System platform with the TWR-SB0410-36EVB configured with another Tower System module, the TWR-KL25Z48M board.

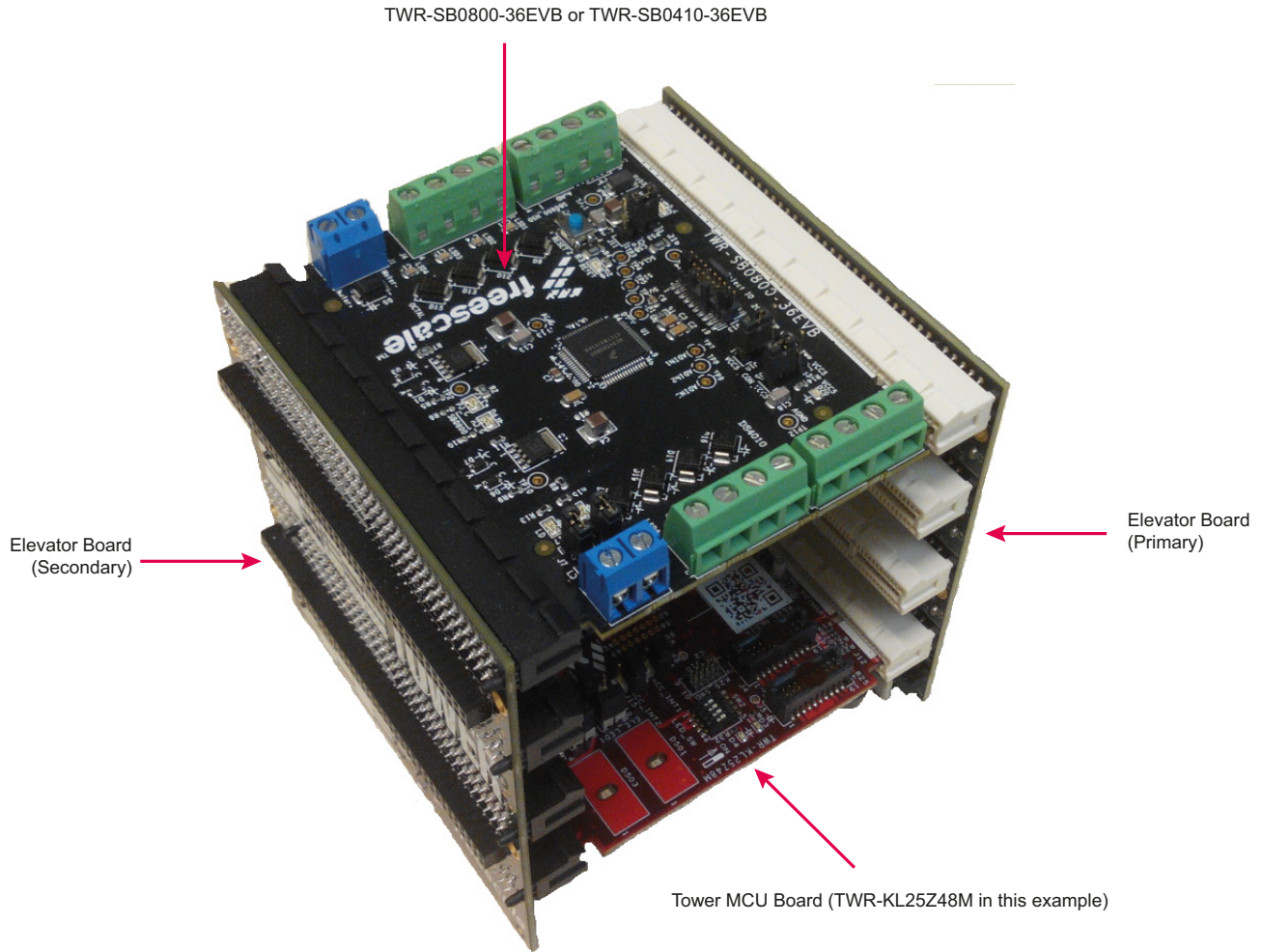

Figure 2. TWR-SB0410-36EVB on tower system

### 3.1 Block diagram

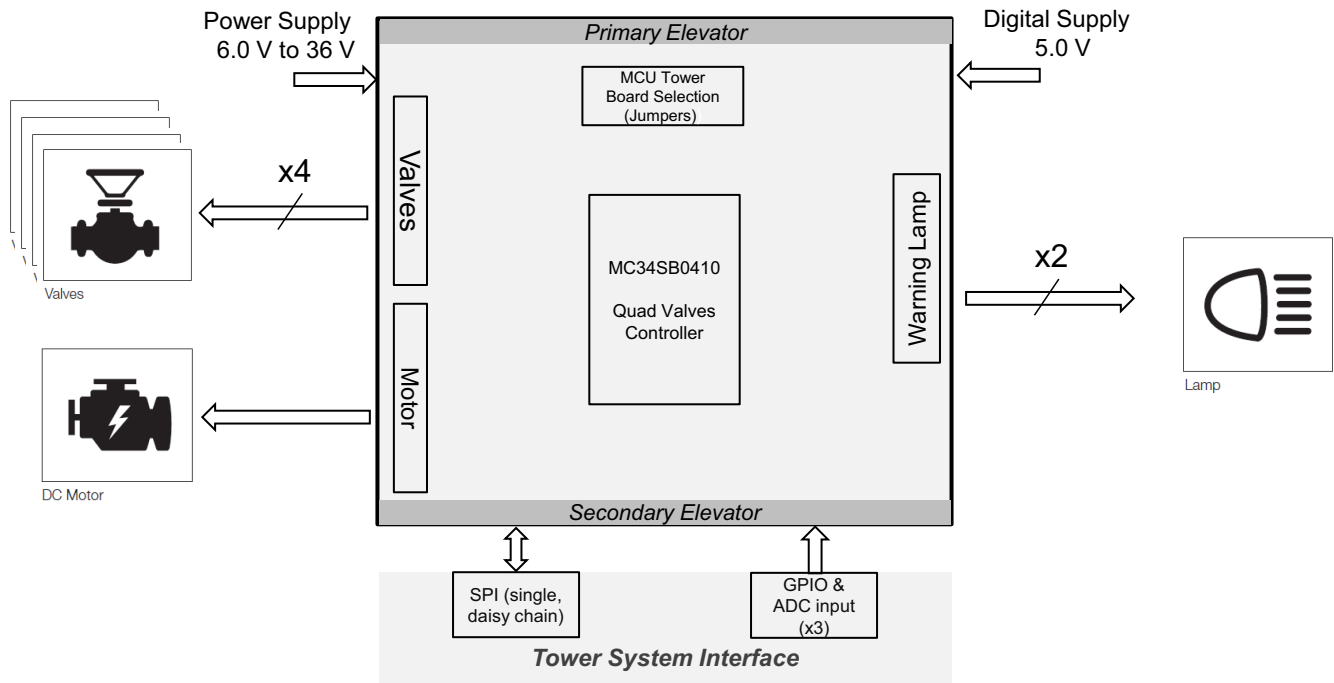

Figure 3. Block diagram

## 4 Getting to know the hardware

### 4.1 Board overview

The TWR-SB0410-36EVB is a tower peripheral module that exercises valve control functions on SoC products based on the Tower System. The Tower System acts as a debug and communication port for the PC being used to debug/download programs from the Kinetis Design Studio/CodeWarrior system.

### 4.2 Board features

The board features are as follows:

- Valves controller with safety features embedded: MC34SB0410
- Four current regulated valve drivers (or PWM) up to 5.0 A
- One high-side pre-driver motor control (up to 16 kHz)
- Embedded safety supervision
- Simple connections with MCU
- Communication via SPI daisy chainable with other TWR-SB0800-36EVB or TWR-SB0410-36EVB (daisy chain mode - jumper selectable)
- Single SPI communication supported
- LED on board indicate ON/OFF status of both low-side (general purpose) channel
- Three ADC (10-bit) inputs

### 4.3 Device features

This tower system features the following NXP product:

**Table 1. Device features**

Device	Description	Features
MC34SB0410	Quad Valve Controller System on Chip	<p><b>Control Features</b></p> <ul style="list-style-type: none"> <li>• Operating voltage up to 36 V</li> <li>• Four low-side drivers regulate up to 2.25 A</li> <li>• <math>\pm 2.0\%</math> precision reachable with calibration or four low-side drivers PWM up to 5 kHz with a maximum current capability up to 5.0 A</li> <li>• All low-side drivers are integrated to save PCB space</li> <li>• One high-side pre-driver for DC Motor Control (up to 16 kHz)</li> <li>• ADC can monitor external or internal signals to enhance the control unit safety level</li> <li>• Only one SPI is needed to control the device</li> <li>• Only one SPI access to write the current or a PWM command is needed</li> <li>• MCU does not need to generate PWM signals at high frequency</li> </ul> <p><b>Safety Features</b></p> <ul style="list-style-type: none"> <li>• Undervoltage, overvoltage clock fail detection</li> <li>• Open load, short circuit, overtemperature detection on each low-side</li> <li>• <math>V_{DS}</math> monitoring of each low-side driver in real time</li> <li>• Overcurrent</li> </ul>

## 4.4 Board Description

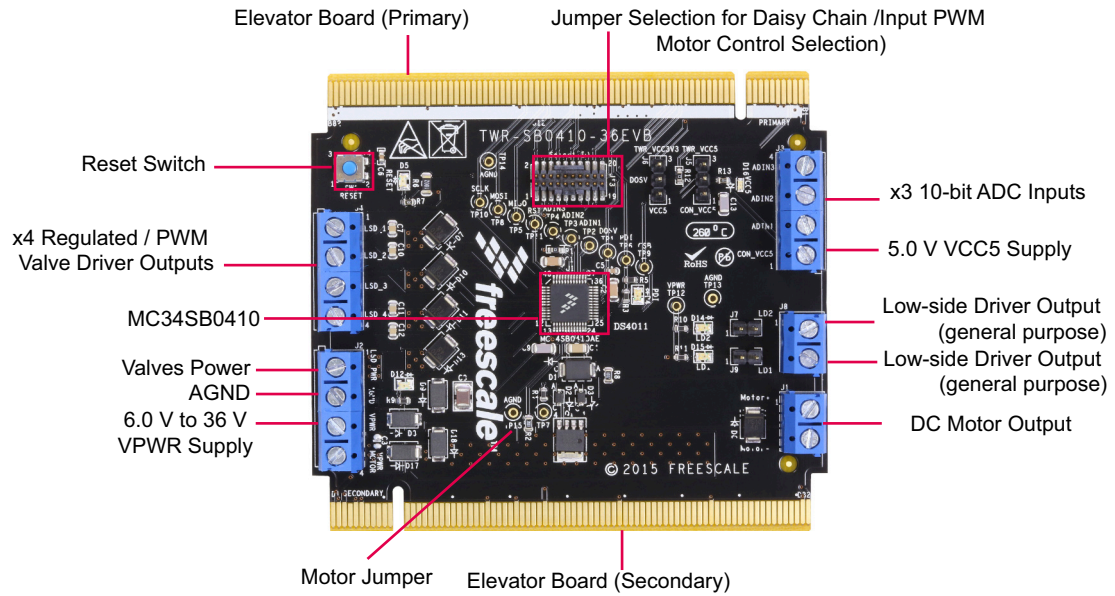

Figure 4. Board overview

Table 2. Board description

Name	Description
Reset button	Resets the MC34SB0410 device
Four Regulated / PWM Valve Driver Outputs	Current Regulated (or PWM) valves output up to 2.25 A, 5 KHz (or 5.0 A, up to 5 KHz)
Valves Power	Provides supply to all valves connected
AGND	Ground connector header
6.0 V to 36 V VPWR Supply	Power supply for power stage
Motor Jumper	Connect / disconnect the motor jumper for test
Secondary Connector	Plug into secondary elevator board
DC motor output	DC motor output up to 500 Hz
Low-side Driver Output (general purpose)	General low-side driver output with LED display
Low-side Driver Output (general purpose)	General low-side driver output with LED display
5.0 V VCC5 Supply	External 5.0 V supply input for Digital (not mandatory if J5, J6 are selecting the 5.0 V tower supply)
Three 10-bit ADC inputs	10-bit ADC input for external monitoring (general / safety purpose)
Select the 5.0 V - 3.3 V Tower supply or 5.0 V external supply	Select the 5.0 V - 3.3 V Tower supply or 5.0 V external supply
Jumpers Selection for Daisy Chain / input PWM motor control	Jumpers selection for Daisy Chain / input PWM motor control
Primary Connector	Plug into primary elevator board



### 4.4.1 LED display

The following LEDs are provided as visual output devices for the TWR-SB0410-36EVB:

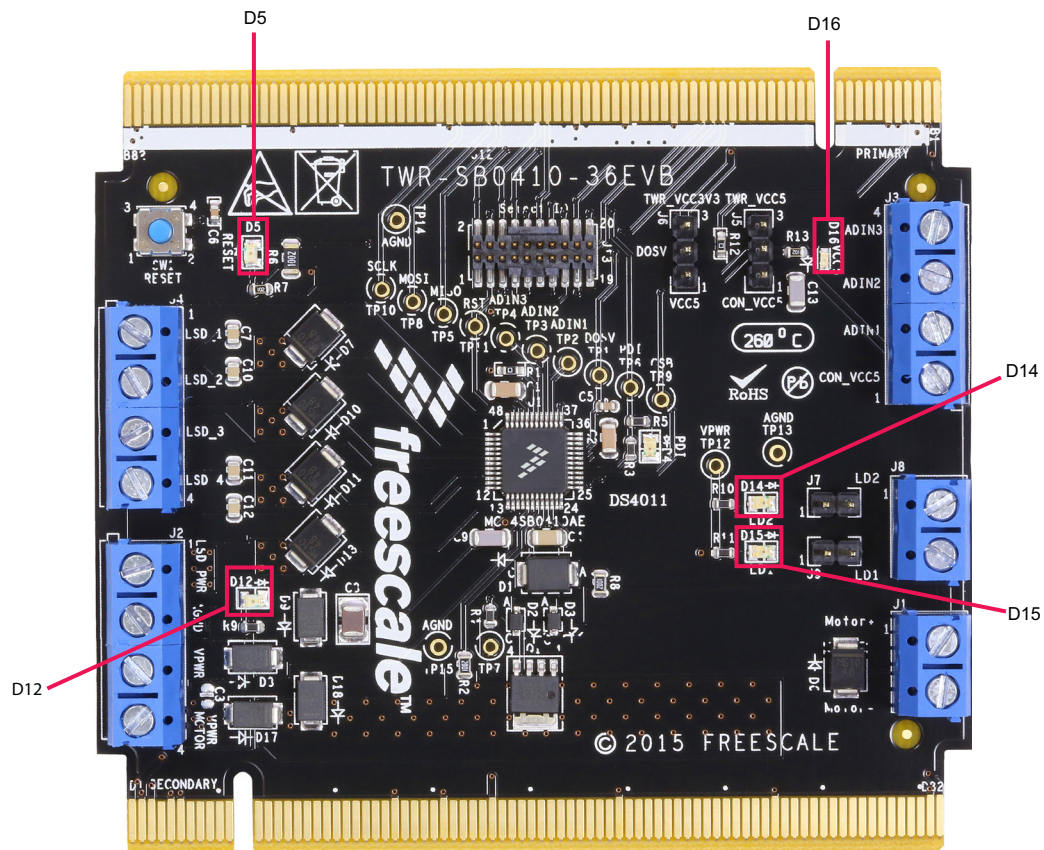

Figure 5. LED locations

Table 3. LEDs

LED ID	Description
D5	Indicates when MC34SB0410 is in Reset or Safe / Normal Mode (Reset = Blinking, ON = Safe or Normal Mode)
D12	Indicates when VPWR power supply is ON
D14	Indicates when low-side driver 2 (general purpose) is ON state
D15	Indicates when low-side driver 1 (general purpose) is ON state
D16	Indicates when digital supply is ON

### 4.4.2 Test point definitions

The following test points are provided for signal analysis of the MC34SB0410 device.

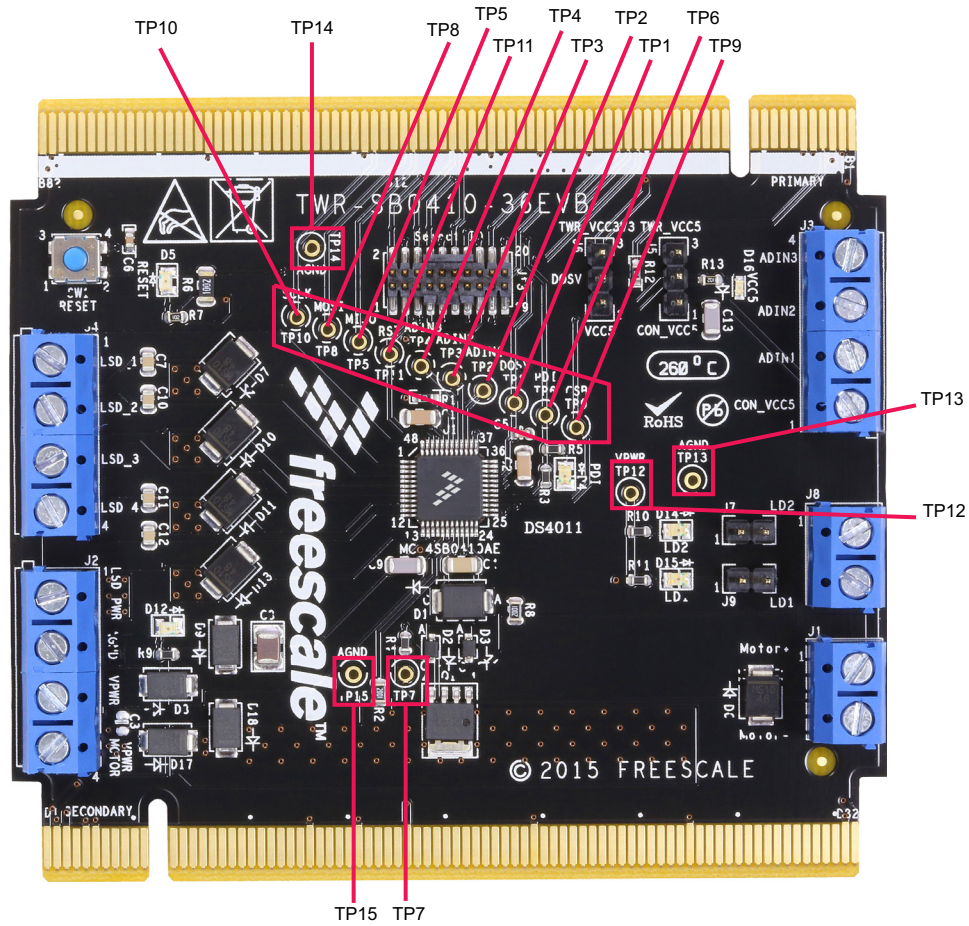

Figure 6. Test point locations

Table 4. Test points

Schematic label	Description
TP1	Indicates DOSV signal (digital output signal)
TP2	Indicates ADIN1 signal (10-bit ADC)
TP3	Indicates ADIN2 signal (10-bit ADC)
TP4	Indicates ADIN3 signal (10-bit ADC)
TP5	Indicates MISO signal
TP6	Indicates PDI input for DC motor gate driver signal
TP7 & TP15	Power jumper connections that can be used for Motor signal analysis
TP8	Indicates MOSI signal
TP9	Indicates SPI / Chip Select signal
TP10	Indicates SPI clock signal
TP11	Indicates Reset signal

Table 4. Test points (continued)

Schematic label	Description
TP12	Indicates VPWR signal
TP13 & TP14	Indicates AGND signal

### 4.4.3 Connectors

Input/output connectors provide the following signals:

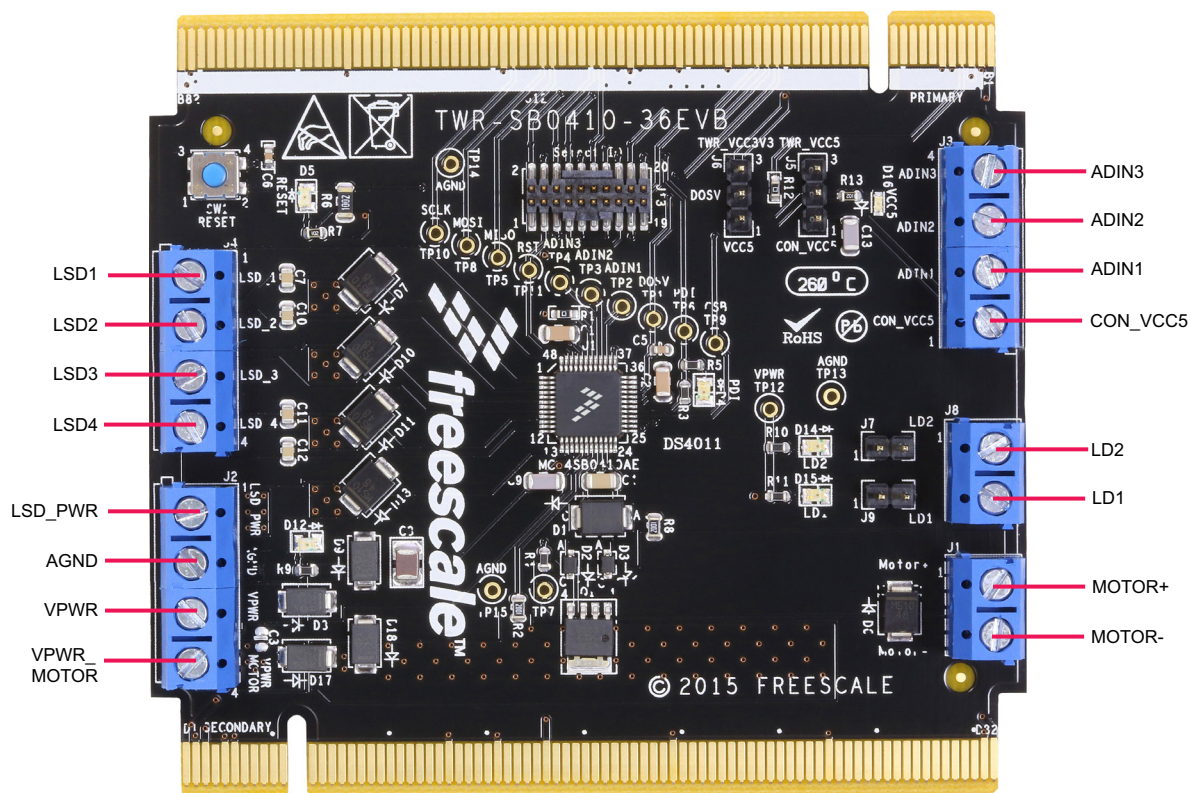

Figure 7. Connector locations

Table 5. Connectors

Name	Description
LSD1	Regulated / PWM valve drivers output 1 of MC34SB0410
LSD2	Regulated / PWM valve drivers output 2 of MC34SB0410
LSD3	Regulated / PWM valve drivers output 3 of MC34SB0410
LSD4	Regulated / PWM valve drivers output 4 of MC34SB0410
LSD_PWR	Valves supply output of MC34SB0410
AGND	Ground input of MC34SB0410
VPWR	Power supply input of MC34SB0410
VPWR_MOTOR	DC motor power supply input of MC34SB0410
Motor -	DC motor negative output of MC34SB0410
Motor +	DC motor positive output of MC34SB0410
LD1	Low-side driver 2 (general purpose) output of MC34SB0410

**Table 5. Connectors (continued)**

Name	Description
LD2	Low-side driver 1 (general purpose) output of MC34SB0410
CON_VCC5	5.0 V external digital input of MC34SB0410
ADIN1	10-bit ADC input 3 of MC34SB0410
ADIN2	10-bit ADC input 2 of MC34SB0410
ADIN3	10-bit ADC input 1 of MC34SB0410

### 4.4.4 Jumper definitions

Figure 8 and Table 6 define the jumper positions and explains their functions. The default settings are shown in bold.

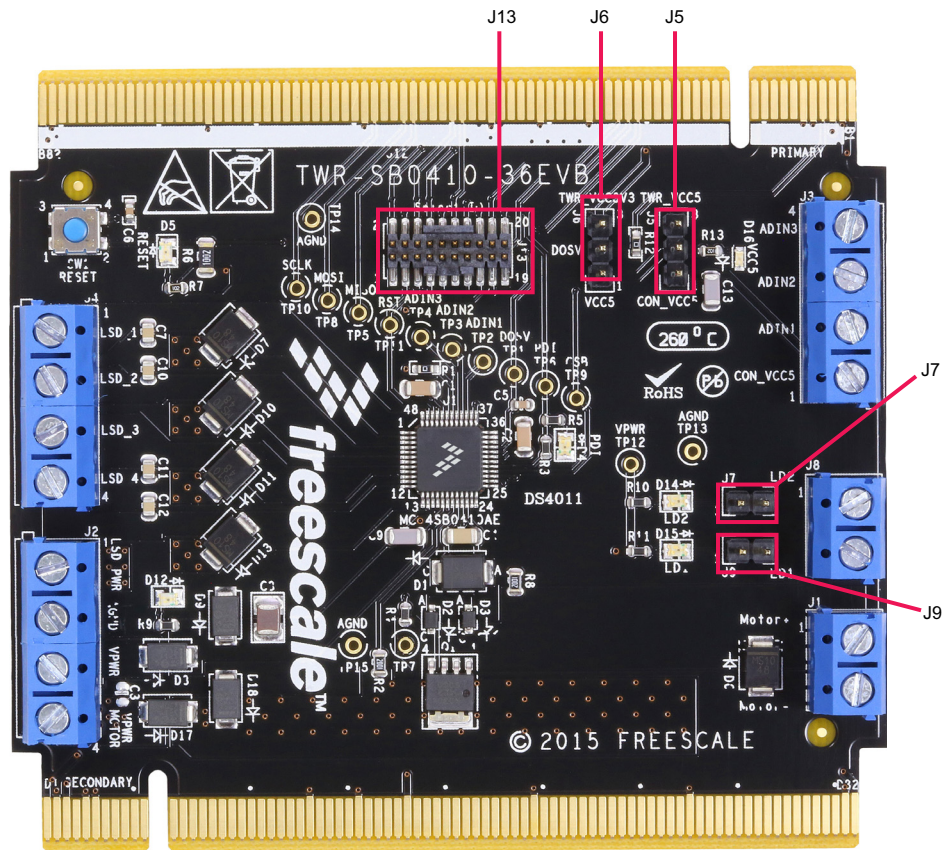

**Figure 8. Jumper locations**

**Table 6. Jumpers**

Jumper	Description	Setting	Connection
J5	Selects the Tower 5.0 V supply or the 5.0 V external supply	1-2	External 5.0 V Supply
		<b>2-3</b>	Tower 5.0 V Supply
J6	Selects the digital voltage level 5.0 V or 3.3 V	<b>1-2</b>	5.0 V Digital Voltage Level
		2-3	3.3 V Digital Voltage Level
J7	Connect / disconnect the LED as a load for the low-side driver 2 (general purpose)	<b>1-2</b>	LED connected
		Not connected	LED disconnected

**Table 6. Jumpers (continued)**

Jumper	Description	Setting	Connection
J9	Connect / disconnect the LED as a load for the low-side driver 1 (general purpose)	1-2	LED connected
		Not connected	LED disconnected
J13	Selects compatibility settings when using additional tower boards	Multiple	See <a href="#">Section 5.2 "Tower board settings"</a>

## 5 Setting Up the hardware

### 5.1 Configuring the hardware

Table 7 shows jumper settings for various MCU Tower Boards. Figure 9 shows a typical configuration using the TWR-KL25Z48M and the jumper settings outlined in red in Table 7.

Table 7. MCU tower board TWR-KL25Z48M jumper settings

	TWR-KL25Z48M	TWR-KV31F120M	TWR-KV10Z32	TWR-K64F120M	TWR-K20	TWR-K22F120	TWR-K70
RSTB	GPIO1	GPIO1	GPIO1	GPIO1	GPIO8	GPIO1	GPIO2
CSB	GPIO2	GPIO2	GPIO2	GPIO2	GPIO9	GPIO2	GPIO3
PDI	PWM4	PWM4	PWM4	PWM4	PWM4	PWM0	PWM4

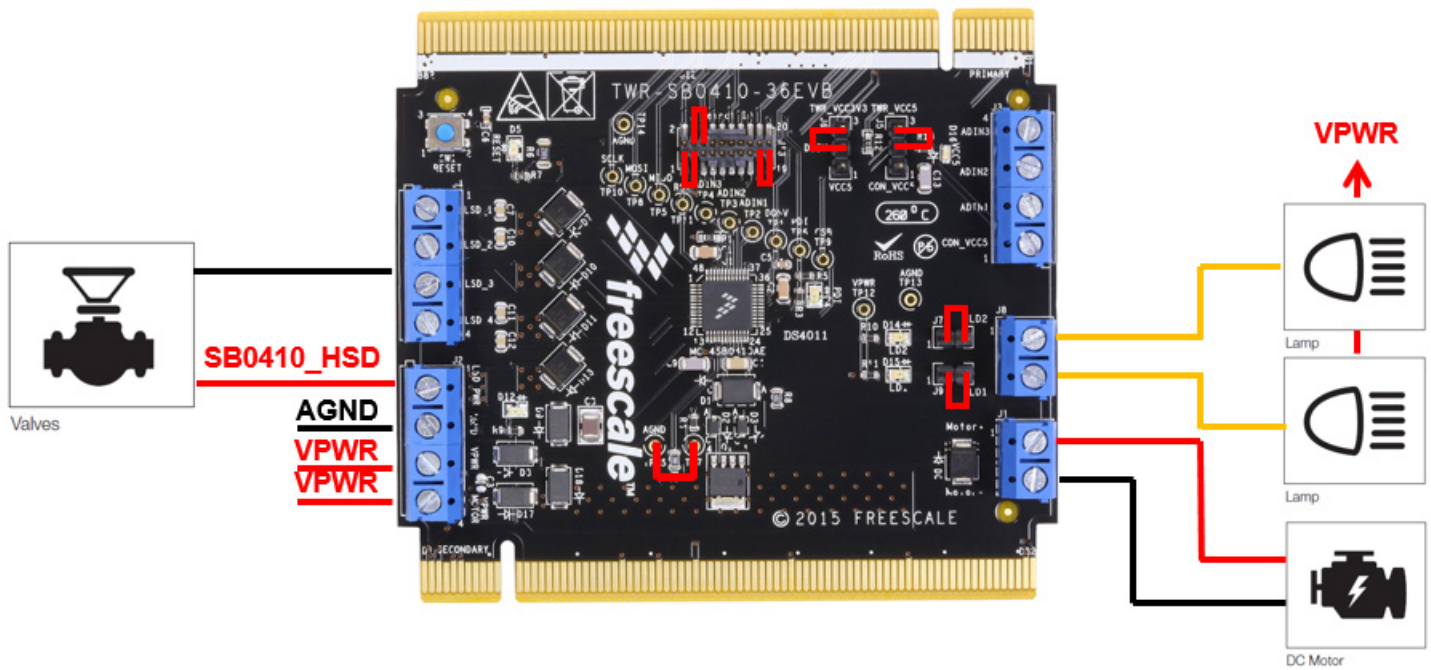

Figure 9. Configuration example

## 5.2 Tower board settings

A jumper block (J13) on the TWR-SB0410-36EVB provides a means of configuring the board for use with additional MCUs. The J13 jumper settings define the routing of all SPI signals, the reset signal from the MCU, and the PWM motor control signal. In addition, jumper J6 allows you to select between either 3.3 V or 5.0 V depending on the requirement of the MCU being used.

Make sure that you set jumper J6 to the proper voltage level and set the jumpers on J13 to feasible positions. Check the schematic of each tower elevator board to assure that all signals are correctly connected.

Figure 10 shows the selection options on the TWR-SB0410-36EVB.

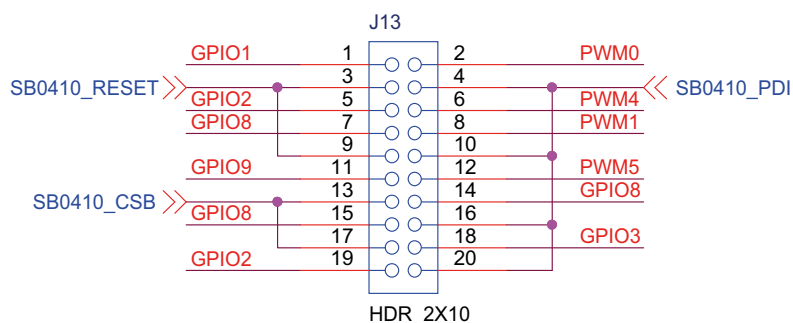

Figure 10. Jumpers for IO selection

Blue text indicates signals coming from the MC34SB0410 of the TWR-SB0410-36EVB.

Red text indicates signals coming from the tower elevator board (Primary and Secondary).

Table 8 shows feasible J13 jumper settings for compatible tower boards. These settings are important because the **Reset** (RSTB) and **Chip Select** (CSB) signals must be routed to MCU IO header positions that can handle such signals.

Table 8. Jumper Settings for Compatible Tower Boards

	TWR-KL25Z48M	TWR-KV31F120M	TWR-KV10Z32	TWR-K64F120M	TWR-K20	TWR-K22F120	TWR-K70
RSTB	GPIO1	GPIO1	GPIO1	GPIO1	GPIO8	GPIO1	GPIO2
CSB	GPIO2	GPIO2	GPIO2	GPIO2	GPIO9	GPIO2	GPIO3
PDI	PWM4	PWM4	PWM4	PWM4	PWM4	PWM0	PWM4

## 5.3 Step-by-step instructions for setting up the hardware

To perform the demonstration examples, the following connections and setup must be performed:

1. Mount the TWR-SB0410-36EVB and TWR-KL25Z48M (for example) board firmly to the tower elevator connectors.
2. Connect the positive "VPWR" wire (from power supply) to the positive "VPWR" connector of TWR-SB0410-36EVB and the negative "AGND" wire to the negative "AGND" wire.
3. Check if all jumpers are in the defaults position of TWR-SB0410-36EVB and the TWR-KL25Z48M board (refer to the tower MCU board User Guide) to a power supply.
4. Attach a USB mini-cable between the PC and the USB mini-plug connector on the TWR-KL25Z48M board. This cable serves as the VCC5 supply and the communication link between the tower boards platform and the PC.

# 6 Schematics

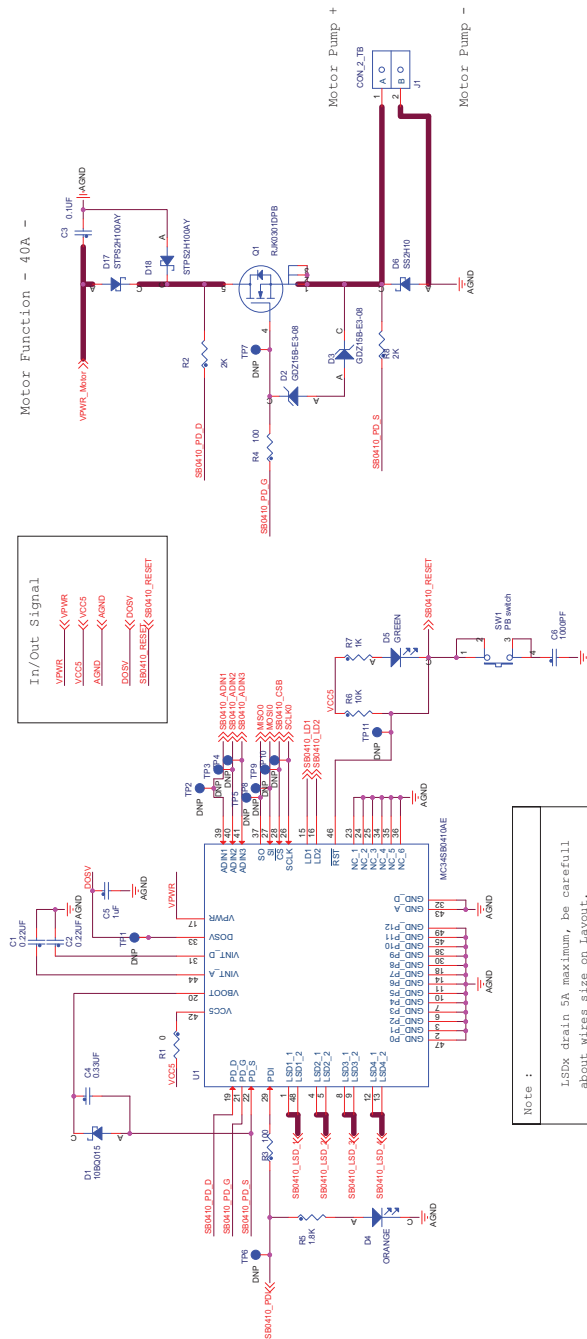

Figure 11. Schematic Part 1



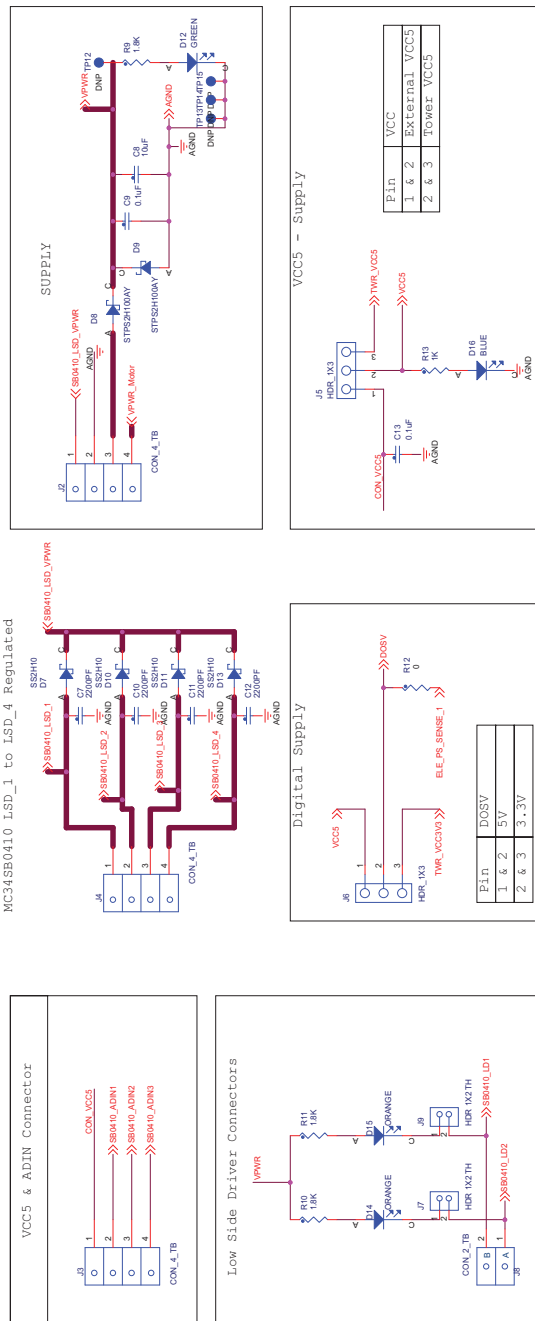

Figure 12. Schematic part 2

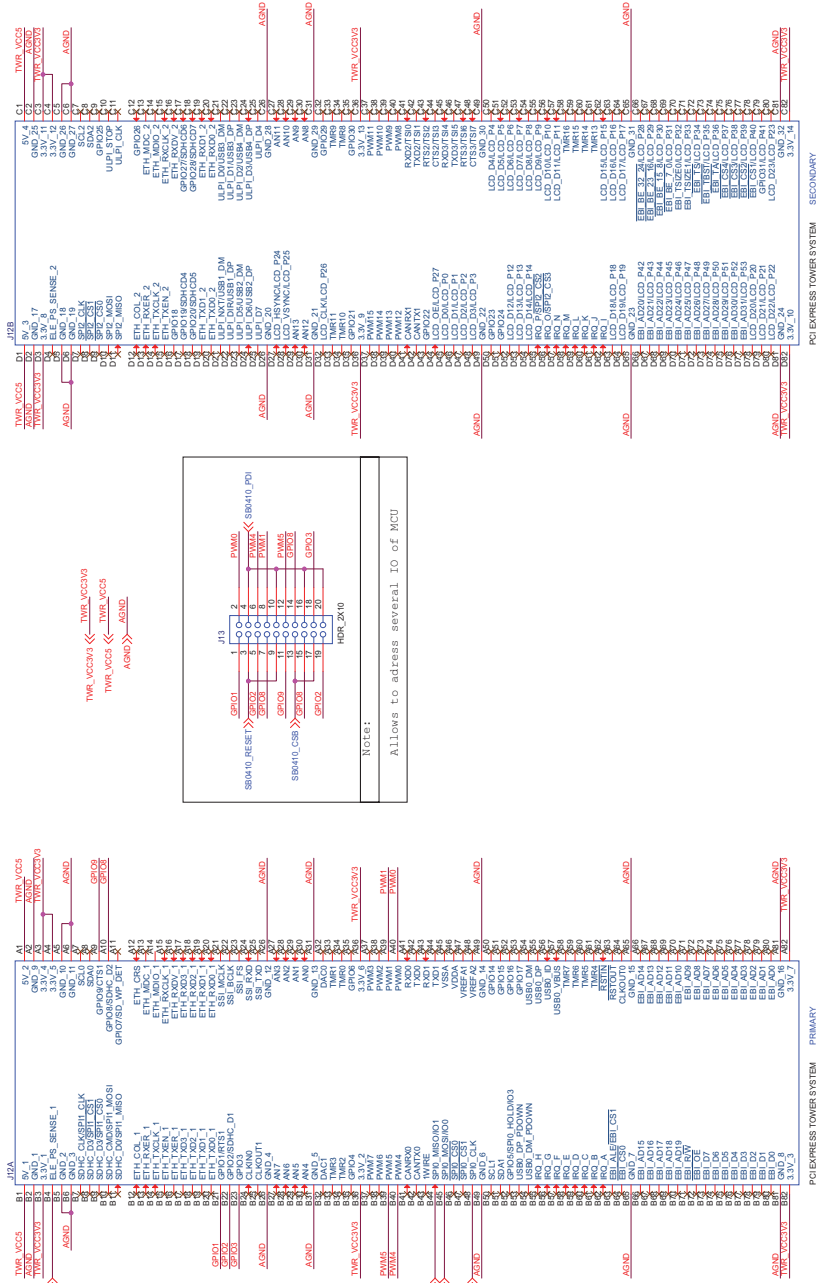
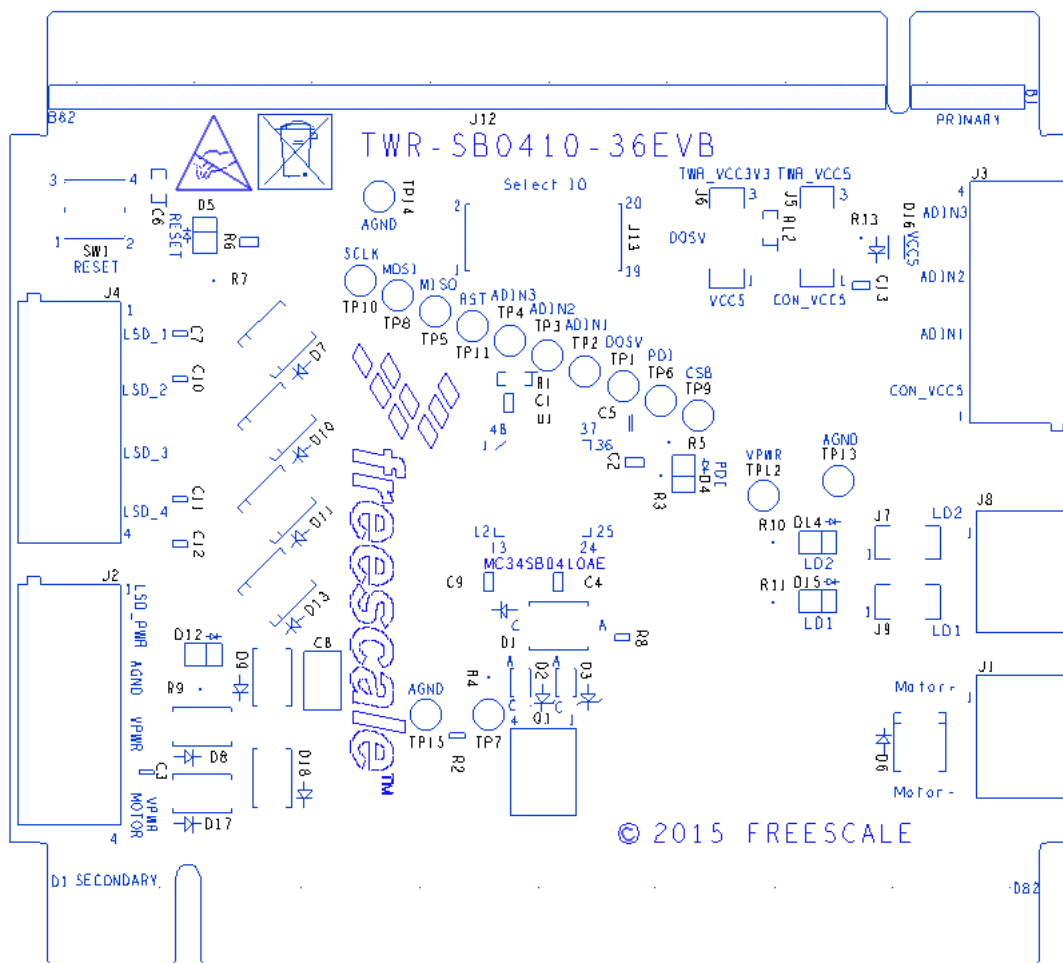

Figure 13. Schematic part 3

# 7 Board layout

## 7.1 Silkscreen



## 8 Board bill of materials

Table 9. Bill of materials <sup>(1)</sup>

Item	Qty	Schematic label	Value	Description	Part Number	Assy opt
<b>NXP components</b>						
1	1	U1		IC CHIP VALVES AND PUMP CTRL 5.0 V/3.3 V LQFP48	MC34SB0410AE	
<b>Capacitors</b>						
2	2	C1, C2	0.22 $\mu$ F	CAP CER 0.22 $\mu$ F 50 V 5% X7R 1206	C1206C224J5RACTU	
3	1	C3	0.1 $\mu$ F	CAP CER 0.1 $\mu$ F 50 V 10% X7R 0603	GRM188R71H104KA93D	(2)
4	1	C4	0.033 $\mu$ F	CAP CER 0.33 $\mu$ F 50 V 10% X7R 1206	MCCE334K3NRTF	
5	1	C5	1.0 $\mu$ F	CAP CER 1 $\mu$ F 25 V 10% X7R 0603	0603X105K250SNT	
6	1	C6	1000 PF	CAP CER 1000 PF 25 V 5% C0G CC0603	C0603C102J3GAC	
7	4	C7, C10, C11, C12	2200 PF	CAP CER 2200 PF 50 V 5% X7R 0805	MCCE222J2NRTF	
8	1	C8	10 $\mu$ F	CAP CER 10 $\mu$ F 50 V 10% X7S AEC-Q200 1210	GCM32EC71H106KA03	
9	2	C9, C13	0.1 $\mu$ F	CAP CER 0.1 $\mu$ F 50 V 5% C0G AEC-Q200 1206	CGA5L2C0G1H104J160AA	
<b>Diodes</b>						
10	1	D1	10BQ015	DIODE SCH RECT 1.0 A 15 V SMB	10BQ015TRPBF	
11	2	D2, D3	GDZ15B-E3-08	DIODE ZNR 5.0 MA 15 V 0.2 W AEC-Q101 SOD-323	GDZ15B-E3-08	
12	3	D4, D14, D15	ORANGE	LED OR SGL 30 MA 0805 SMT	APHCM2012SECK-F01	
13	2	D5, D12	GREEN	LED GRN SGL 30 MA SMT 0805	LTST-C171KGTK	
14	5	D6, D7, D10, D11, D13	SS2H10	DIODE SCH RECT 2.0 A 100V DO-214AA	SS2H10-E3/52T	
15	4	D8, D9, D17, D18	STPS2H100AY	DIODE PWR RECT SCH 2.0 A 100 V AEC-Q101 SMA	STPS2H100AY	
16	1	D16	BLUE	LED BLUE SGL 30 mA 2.6 V 0603	UT-692NB	
<b>Resistors</b>						
17	1	R1	0 $\Omega$	RES MF ZERO OHM 1/10 W -- AEC-Q200 0603	CRCW06030000Z0EA	
18	2	R2, R8	2.0 K	RES MF 2 K 1/8 W 1% 0805	CR0805-FX-2001ELF	
19	2	R3, R4	100 $\Omega$	RES MF 100 OHM 1/10W	CRCW0603100RFKEA	
20	4	R5, R9, R10, R11	1.8 K	RES MF 1.8 K 1/10 W 5% 0603	WR06X182JTL	
21	1	R6	10 K	RES MF 10 K 1/4 W 5% 1206	CR1206JW103ELF	
22	2	R7, R13	1.0 K	RES MF 1.0 K 1/10 W 0.5% 0603	MCT06030C1001DP500	
23	1	R12	0 $\Omega$	RES MF ZERO OHM 1/10 W	CRCW06030000Z0EA	(2)
<b>Switches, Connectors, Jumpers and Test Points</b>						
24	2	J1, J8	CON_2_TB	HDR 2x8 2.54 MM FEMALE (STACKABLE) - SAMTEC	SSQ-108-23-G-D	
25	3	J2, J3, J4	CON_4_TB	HDR 2x10 2.54 MM FEMALE (STACKABLE) - SAMTEC	SSQ-110-23-G-D	

Table 9. Bill of materials <sup>(1)</sup> (continued)

Item	Qty	Schematic label	Value	Description	Part Number	Assy opt
26	2	J5, J6	HDR_1X3	CON 1x5 USB MINI-B RA SHLD SKT SMT 0.8 MM SP 156HAU -- HIROSE	UX60-MB-5ST	
27	2	J7, J9	HDR 1X2 TH	HDR 1x2 TH 100 MIL SP 339H AU 118L - HARWIN INC	M20-9990245	
28	1	J12	PCI EXPRESS TOWER SYSTEM	CON 1X3 TB TH 3.81 MM SP 201H -- 138L + TERM BLOCK PLUG 3.81 MM 3POS - SUBASSEMBLY	210-80099, 211-79220	
29	1	J13	HDR_2X10	CON 1X2 TB TH 3.81 MM SP 201H -- 138L + TERM BLOCK PLUG 3.81 MM 2POS - SUBASSEMBLY	210-8009, 210-80098	
30	1	Q1	RJK0301DPB	TRANS NMOS PWR 24 A 30 V SO8 - Vishay Technology	SI4156DY-T1-GE3	
31	15	TP1, TP2, TP3, TP4, TP5, TP6, TP7, TP8, TP9, TP10, TP11, TP12, TP13, TP14, TP15	TEST POINT WHITE	TEST POINT WHITE 40 MIL DRILL 180 MIL TH 109L	5002	<sup>(2)</sup>
32	1	SW1		SW SMT 4.0 MM FMS 0.1 A MAX 16 V MAX ROHS COMPLIANT	7914J-1-000E	

## Notes

1. NXP does not assume liability, endorse, or warrant components from external manufacturers are referenced in circuit drawings or tables. While NXP offers component recommendations in this configuration, it is the customer's responsibility to validate their application.
2. Do Not Populate

## 9 References

Following are URLs where you can obtain information on related NXP products and application solutions:

**Table 10. References**

NXP support pages	Description	URL
TWR-SB0410-36EVB	Tool Summary Page	<a href="http://www.nxp.com/TWR-SB0410-36EVB">http://www.nxp.com/TWR-SB0410-36EVB</a>
MC34SB0410	Product Summary Page	<a href="http://www.nxp.com/MC34SB0410">http://www.nxp.com/MC34SB0410</a>
Tower System	Tower System Modular Development Board Platform	<a href="http://www.nxp.com/tower">http://www.nxp.com/tower</a>
TWR-KL25Z48M	Tool Summary Page	<a href="http://www.nxp.com/TWR-KL25Z48M">http://www.nxp.com/TWR-KL25Z48M</a>
K20D72M	Tool Summary Page	<a href="http://www.nxp.com/K20D72M">http://www.nxp.com/K20D72M</a>
KV31F120M	Tool Summary Page	<a href="http://www.nxp.com/KV31F120M">http://www.nxp.com/KV31F120M</a>
Kinetis Design Studio	Software	<a href="http://www.nxp.com/kinetis">http://www.nxp.com/kinetis</a>
CodeWarrior	Software	<a href="http://www.nxp.com/codewarrior">http://www.nxp.com/codewarrior</a>

## 9.1 Support

Visit [www.nxp.com/support](http://www.nxp.com/support) for a list of phone numbers within your region.

## 9.2 Warranty

Visit [www.nxp.com/warranty](http://www.nxp.com/warranty) to submit a request for tool warranty.

## 10 Revision history

Revision	Date	Description of Changes
1.0	1/2016	<ul style="list-style-type: none"><li>Initial release</li></ul>
	7/2016	<ul style="list-style-type: none"><li>Updated to NXP document form and style</li></ul>



**How to Reach Us:****Home Page:**[NXP.com](http://www.nxp.com)**Web Support:**<http://www.nxp.com/support>

Information in this document is provided solely to enable system and software implementers to use NXP products. There are no expressed or implied copyright licenses granted hereunder to design or fabricate any integrated circuits based on the information in this document. NXP reserves the right to make changes without further notice to any products herein.

NXP makes no warranty, representation, or guarantee regarding the suitability of its products for any particular purpose, nor does NXP assume any liability arising out of the application or use of any product or circuit, and specifically disclaims any and all liability, including without limitation, consequential or incidental damages. "Typical" parameters that may be provided in NXP data sheets and/or specifications can and do vary in different applications, and actual performance may vary over time. All operating parameters, including "typicals," must be validated for each customer application by the customer's technical experts. NXP does not convey any license under its patent rights nor the rights of others. NXP sells products pursuant to standard terms and conditions of sale, which can be found at the following address:

<http://www.nxp.com/terms-of-use.html>.

NXP, the NXP logo, Freescale, the Freescale logo, and SMARTMOS are trademarks of NXP B.V. All other product or service names are the property of their respective owners. All rights reserved.

© 2016 NXP B.V.

Document Number: KTTWRSB0410-36EVBUG

Rev. 1.0

7/2016

