

# Errata to MPC8245 Integrated Processor Reference Manual, Rev. 3

This errata describes corrections to the *MPC8245 Integrated Processor Reference Manual*, Revision 3. Unless noted otherwise, listed changes to the reference manual that refer to the MPC8245 also apply to the MPC8241. For convenience, the section number and page number of the errata item in the reference manual are provided. Items in bold are new since the last revision of this document.

To locate any published updates for this document, visit our website listed on the back cover of this document.

- 4.1.3.1, 4-3            In Table 4-1, “Configuration Registers Accessible from the Processor Core,” for PCI status register, add additional reset value of 0x0020 (post-R1.4).
- 4.1.3.1, 4-6            In Figure 4-1, “Processor Accessible Configuration Space,” for offset address hexadecimal E0, replace the reserved register at offset 0xE3 with DLL tap count register.
- 4.3.2, 4-18**            In Table 4-18, “Power Management Configuration Register 2—0x72,” modify the first sentence of the field description of DLL\_EXTEND (bit 7) to say, “This bit can be used to shift the lock-range of the DLL by half of an SDRAM clock cycle.”
- 5.4.2.3, 5-22            Replace information regarding AN1767 with AN2129, as follows: “*Instruction and Data Cache Locking on the e300 Processor Core* application note (order number: AN2129).”
- 6.2.3, 6-14            In Table 6-9, “SDRAM System Configurations,” change entry for “in-line RMW parity enabled” to “INLINE\_WR\_EN = 0 due to Chip Errata #17.”
- 6.3.4.2, 6-57            Replace Figure 6-41, “8-Bit ROM/Flash Interface—Single-Byte Read Timing,” with the following figure:

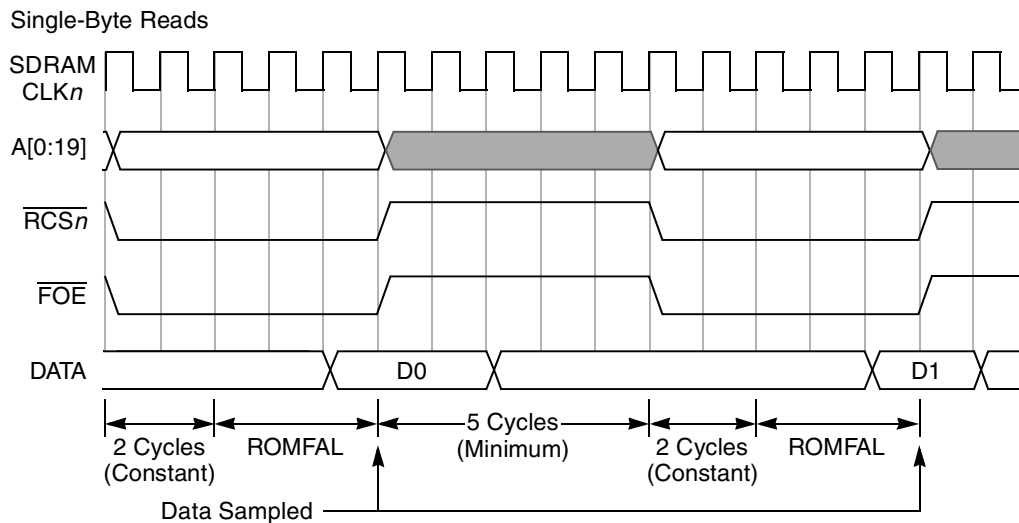

**Figure 6-41. 8-Bit ROM/Flash Interface—Single-Byte Read Timing**

6.3.5.4, 6-64

Replace Figure 6-49, “Port X Handshake Mode Read Timing,” with the following figure:

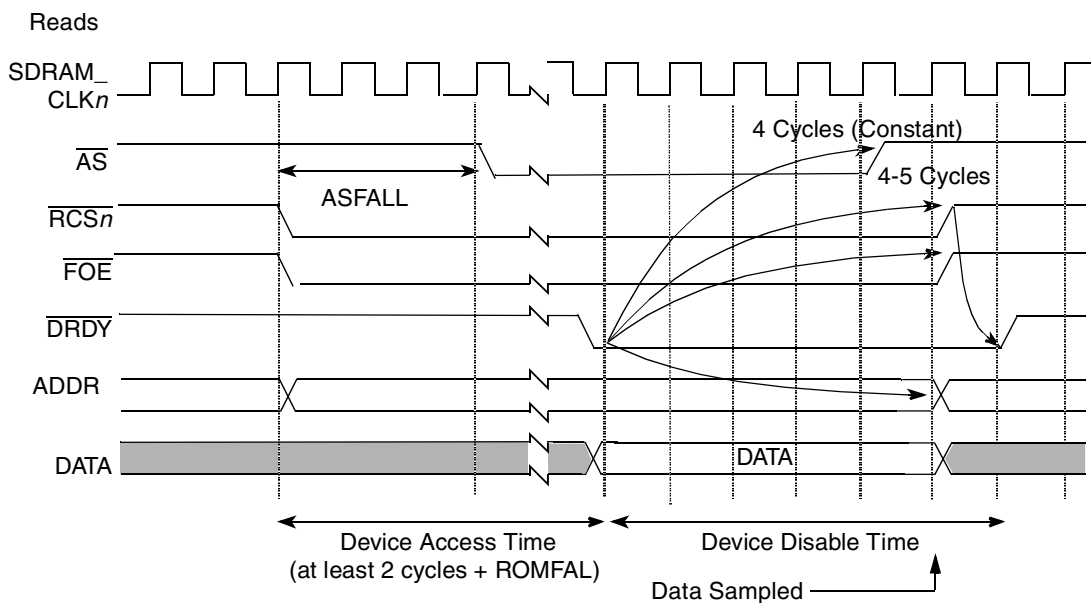

**Figure 6-49. Port X Handshake Mode Read Timing**

6.3.5.4, 6-65

Replace Figure 6-50, “Port X Handshake Mode Write Timing,” with the following figure:

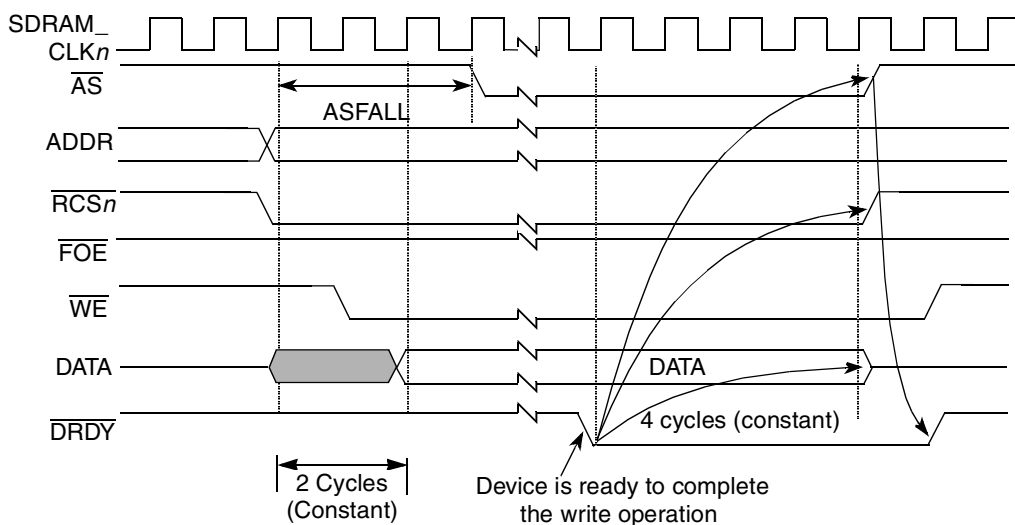

**Figure 6-50. Port X Handshake Mode Write Timing**

## **How to Reach Us:**

### **Home Page:**

[www.freescale.com](http://www.freescale.com)

### **Web Support:**

<http://www.freescale.com/support>

### **USA/Europe or Locations Not Listed:**

Freescale Semiconductor, Inc.  
Technical Information Center, EL516  
2100 East Elliot Road  
Tempe, Arizona 85284  
1-800-521-6274 or  
+1-480-768-2130  
[www.freescale.com/support](http://www.freescale.com/support)

### **Europe, Middle East, and Africa:**

Freescale Halbleiter Deutschland GmbH  
Technical Information Center  
Schatzbogen 7  
81829 Muenchen, Germany  
+44 1296 380 456 (English)  
+46 8 52200080 (English)  
+49 89 92103 559 (German)  
+33 1 69 35 48 48 (French)  
[www.freescale.com/support](http://www.freescale.com/support)

### **Japan:**

Freescale Semiconductor Japan Ltd.  
Headquarters  
ARCO Tower 15F  
1-8-1, Shimo-Meguro, Meguro-ku  
Tokyo 153-0064  
Japan  
0120 191014 or  
+81 3 5437 9125  
[support.japan@freescale.com](mailto:support.japan@freescale.com)

### **Asia/Pacific:**

Freescale Semiconductor China Ltd.  
Exchange Building 23F  
No. 118 Jianguo Road  
Chaoyang District  
Beijing 100022  
China  
+86 10 5879 8000  
[support.asia@freescale.com](mailto:support.asia@freescale.com)

### **For Literature Requests Only:**

Freescale Semiconductor  
Literature Distribution Center  
P.O. Box 5405  
Denver, Colorado 80217  
1-800 441-2447 or  
+1-303-675-2140  
Fax: +1-303-675-2150  
[LDCForFreescaleSemiconductor@hibbertgroup.com](mailto:LDCForFreescaleSemiconductor@hibbertgroup.com)

Information in this document is provided solely to enable system and software implementers to use Freescale Semiconductor products. There are no express or implied copyright licenses granted hereunder to design or fabricate any integrated circuits or integrated circuits based on the information in this document.

Freescale Semiconductor reserves the right to make changes without further notice to any products herein. Freescale Semiconductor makes no warranty, representation or guarantee regarding the suitability of its products for any particular purpose, nor does Freescale Semiconductor assume any liability arising out of the application or use of any product or circuit, and specifically disclaims any and all liability, including without limitation consequential or incidental damages. "Typical" parameters which may be provided in Freescale Semiconductor data sheets and/or specifications can and do vary in different applications and actual performance may vary over time. All operating parameters, including "Typicals" must be validated for each customer application by customer's technical experts. Freescale Semiconductor does not convey any license under its patent rights nor the rights of others. Freescale Semiconductor products are not designed, intended, or authorized for use as components in systems intended for surgical implant into the body, or other applications intended to support or sustain life, or for any other application in which the failure of the Freescale Semiconductor product could create a situation where personal injury or death may occur. Should Buyer purchase or use Freescale Semiconductor products for any such unintended or unauthorized application, Buyer shall indemnify and hold Freescale Semiconductor and its officers, employees, subsidiaries, affiliates, and distributors harmless against all claims, costs, damages, and expenses, and reasonable attorney fees arising out of, directly or indirectly, any claim of personal injury or death associated with such unintended or unauthorized use, even if such claim alleges that Freescale Semiconductor was negligent regarding the design or manufacture of the part.

Freescale and the Freescale logo are trademarks or registered trademarks of Freescale Semiconductor, Inc. in the U.S. and other countries. All other product or service names are the property of their respective owners. The Power Architecture and Power.org word marks and the Power and Power.org logos and related marks are trademarks and service marks licensed by Power.org.

© Freescale Semiconductor, Inc., 2009. All rights reserved.

