



# M5213EVB

## Development Board for Freescale MCF5213 MCU Hardware User Manual

Information in this document is provided solely to enable system and software implementers to use Freescale Semiconductor products. There are no express or implied copyright licenses granted hereunder to design or fabricate any integrated circuits or integrated circuits based on the information in this document. Freescale Semiconductor reserves the right to make changes without further notice to any products herein. Freescale Semiconductor makes no warranty, representation or guarantee regarding the suitability of its products for any particular purpose, nor does Freescale Semiconductor assume any liability arising out of the application or use of any product or circuit, and specifically disclaims any and all liability, including without limitation consequential or incidental damages. "Typical" parameters which may be provided in Freescale Semiconductor data sheets and/or specifications can and do vary in different applications and actual performance may vary over time. All operating parameters, including "Typicals" must be validated for each customer application by customer's technical experts. Freescale Semiconductor does not convey any license under its patent rights nor the rights of others. Freescale Semiconductor products are not designed, intended, or authorized for use as components in systems intended for surgical implant into the body, or other applications intended to support or sustain life, or for any other application in which the failure of the Freescale Semiconductor product could create a situation where personal injury or death may occur. Should Buyer purchase or use Freescale Semiconductor products for any such unintended or unauthorized application, Buyer shall indemnify and hold Freescale Semiconductor and its officers, employees, subsidiaries, affiliates, and distributors harmless against all claims, costs, damages, and expenses, and reasonable attorney fees arising out of, directly or indirectly, any claim of personal injury or death associated with such unintended or unauthorized use, even if such claim alleges that Freescale Semiconductor was negligent regarding the design or manufacture of the part.

Reconfigured with permission of Axiom Manufacturing

© Freescale Semiconductor, Inc., 2004. All rights reserved.

## CONTENTS

<b>CAUTIONARY NOTES .....</b>	<b>3</b>
<b>TERMINOLOGY .....</b>	<b>3</b>
<b>FEATURES .....</b>	<b>4</b>
<b>GETTING STARTED .....</b>	<b>5</b>
SOFTWARE DEVELOPMENT .....	5
REFERENCE DOCUMENTATION .....	5
M5213EVB STARTUP .....	6
<b>M5213EVB HARDWARE CONFIGURATION AND OPTIONS.....</b>	<b>6</b>
MEMORY .....	6
POWER SUPPLY .....	7
<i>Power Jack</i> .....	7
<i>TB1 Power connection</i> .....	7
<i>ON_OFF Switch</i> .....	7
<i>FUSE – F1</i> .....	7
<i>3.3V_EN Option</i> .....	8
<i>3.3V Indicator</i> .....	8
<i>VDD and VRx Enable Options</i> .....	8
<i>VX_EN Option</i> .....	9
RESET .....	9
<i>RESET Switch</i> .....	9
<i>RESET Indicator</i> .....	9
ABORT SWITCH .....	9
SW1 AND SW2 SWITCHES .....	9
LED[4:1] USER INDICATORS.....	9
<i>LED_EN option</i> .....	10
SYSTEM CLOCK.....	10
<i>CLOCK Option Chart</i> .....	10
UART0_TERMINAL AND UART1 PORTS.....	10
<i>UART0_EN and UART1_EN Options</i> .....	11
UART2_CAN PORT .....	11
<i>COM_SEL Option</i> .....	11
<i>UART2_EN option</i> .....	12
<i>CAN Operation</i> .....	12
<i>CAN_EN option</i> .....	13
JP1 – I2C PULL-UP ENABLE .....	13
MC13192 ZIGBEE™ TRANSCEIVER .....	13
<i>ZIGBEE_EN Option</i> .....	13
<i>TX Power</i> .....	14
<b>M5213EVB I/O PORTS .....</b>	<b>14</b>
BDM_PORT .....	14
<i>BDM_EN Option</i> .....	14
<i>JP2 Option</i> .....	15
<i>BDM Port Connector</i> .....	15
MCU_PORT .....	16

TRUBLESHOOTING.....	17
<b>DBUG MONITOR OPERATION.....</b>	<b>18</b>
dBUG COMMUNICATION: .....	18
dBUG SYSTEM INITIALIZATION .....	18
<i>Interrupt Service Support</i> .....	18
dBUG MEMORY MAP .....	18
dBUG COMMANDS .....	19
<i>dBUG Command Table</i> .....	19
<b>APPENDIX 1: DBUG COMMAND SET .....</b>	<b>21</b>
ASM - ASSEMBLER .....	21
BC - BLOCK COMPARE.....	21
BF - BLOCK FILL.....	22
BM - BLOCK MOVE .....	23
BR - BREAKPOINTS .....	23
BS - BLOCK SEARCH .....	24
DC - DATA CONVERSION .....	25
DI - DISASSEMBLE .....	25
DL - DOWNLOAD CONSOLE .....	26
DLDEBUG – DOWNLOAD dBUG (UPDATE).....	26
FL – FLASH LOAD OR ERASE .....	27
GO – EXECUTE USER CODE .....	27
GT - EXECUTE TO ADDRESS .....	28
IRD - INTERNAL REGISTER DISPLAY.....	28
IRM - INTERNAL REGISTER MODIFY.....	28
HELP - HELP .....	29
LR - LOOP READ .....	29
LW - LOOP WRITE .....	29
MD - MEMORY DISPLAY.....	30
MM - MEMORY MODIFY.....	30
MMAP - MEMORY MAP DISPLAY.....	31
RD - REGISTER DISPLAY .....	31
RM - REGISTER MODIFY .....	32
RESET - RESET THE BOARD AND DBUG.....	32
SET - SET CONFIGURATIONS.....	33
SHOW - SHOW CONFIGURATIONS .....	33
STEP - STEP OVER.....	34
SYMBOL - SYMBOL NAME MANAGEMENT .....	34
TRACE - TRACE INTO .....	35
VERSION - DISPLAY DBUG VERSION.....	35
TRAP #15 FUNCTIONS.....	36
<i>OUT_CHAR</i> .....	36
<i>IN_CHAR</i> .....	36
<i>CHAR_PRESENT</i> .....	37
<i>EXIT_TO_dBUG</i> .....	37

# Cautionary Notes

- 1) Electrostatic Discharge (ESD) prevention measures should be applied whenever handling this product. ESD damage is not a warranty repair item.
- 2) Axiom Manufacturing reserves the right to make changes without further notice to any products to improve reliability, function or design. Axiom Manufacturing does not assume any liability arising out of the application or use of any product or circuit described herein; neither does it convey any license under patent rights or the rights of others.
- 3) EMC Information on the M5213EVB board:
  - a) This device complies with Part 15 of the FCC Rules. Operation is subject to the following two conditions:
    - 1) This device may not cause harmful interference, and
    - 2) This device must accept any interference received, including interference that may cause undesired operation.

TX FCC ID# TFY0605AXM0367

- b) Changes or modifications to this unit not expressly approved by Axiom Manufacturing, could void the user's authority to operate this equipment.
- c) This product as shipped from the factory with associated power supplies and cables, has been tested and meets with requirements of CE IT Equipment **CLASS B** product.
- d) This product is designed and intended for use as a development platform for hardware or software in an educational / professional laboratory.
- e) In a domestic environment this product may cause radio interference in which case the user may be required to take adequate prevention measures.
- f) RF Exposure – This device exceeds the FCC requirements for RF exposure when the antenna used for this transmitter has a separation distance of at least 20cm from all persons and must not be co-located or operating in conjunction with any other antenna or transmitter.

## Terminology

This development board applies option selection jumpers. Terminology for application of the option jumpers is as follows:

Jumper on, in, or installed = jumper is a plastic shunt that fits across 2 pins and the shunt is installed so that the 2 pins are connected with the shunt.

Jumper off, out, or idle = jumper or shunt is installed so that only 1 pin holds the shunt, no 2 pins are connected, or jumper is removed. It is recommended that the jumpers be placed idle by installing on 1 pin so they will not be lost.

Signal names in this document that are followed by an asterisk (\*) denote an active-low signal.

# FEATURES

M5213EVB is a low cost development system for the Freescale MCF5213 ColdFire® microcontroller. Application development is quick and easy with the included DB9 serial cable and dBUG firmware monitor. The BDM port is compatible with standard ColdFire BDM / JTAG interface cables and hosting software, allowing easy application debugging and development with a variety of hardware and software tools.

## Features:

- ◆ MCF5213 CPU, 100 pin LQFP
  - \* 256K Byte Flash (on-chip)
  - \* 32K Byte SRAM (on-chip)
  - \* DMA Controller w/ four 32-bit Timers
  - \* Interrupt Controller
  - \* 8 Channel 12-bit A/D
  - \* QSPI, IIC, and CAN Serial Ports
  - \* 3 UART Serial Ports with DMA capability
  - \* Edge / Interrupt Port
  - \* 8 PWM timers
  - \* 4 16-bit GPT Timers
  - \* BDM / JTAG Port
  - \* Internal 8MHz Oscillator
  - \* 3.3V operation
- ◆ 8MHz reference crystal
- ◆ MCU port, 60 pin I/O port
- ◆ BDM / JTAG Port, 26-pin development port
- ◆ UART0 / Terminal Port w/ RS232 DB9-S Connector
- ◆ UART1 Port w/ RS232 DB9-S Connector
- ◆ UART2 / CAN port w/ RS232 and 1Mbaud CAN transceiver
- ◆ RESET switch and indicator
- ◆ ABORT (IRQ7) switch
- ◆ 4 User Indicators (LEDs)
- ◆ 2 User Push Switches
- ◆ 2.4GHz Zigbee™ capable RF Transceiver
- ◆ Regulated +3.3V power supply w/ indicator
- ◆ Supplied with DB9 Serial Cable, Wall Adapter Power supply, and P&E BDM interface cable.

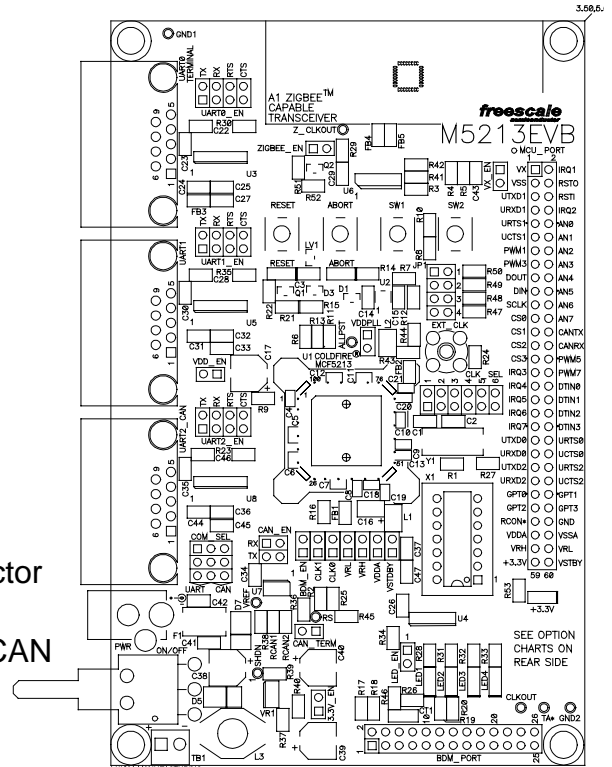

**M5213EVB**

## Specifications:

Board Size 3.5" x 5.5"

Power Input: +5 - +25VDC, 9VDC typical

Current Consumption: 100ma typical @ 9VDC input

The M5213EVB is provided, operating the Freescale dBUG monitor firmware. The monitor allows serial interface to a PC host for file loading and terminal command line operations. The kit is plug in and play out of the box with a wall adapter power supply. Additional hardware and software development tools are available, but not required.

# GETTING STARTED

The M5213EVB single board computer is a fully assembled, fully functional development board for the Freescale MCF5213 microcontroller. It is provided with a wall plug power supply, P&E BDM interface cable, and a serial cable. Provided support software for this development board is for Windows 95/98/NT/2000/XP operating systems.

Development board users should also be familiar with the hardware and software operation of the target MCF5213 device. Refer to the microcontroller reference manual, MCF5213RM, for details. The purpose of the development board is to assist the user in quickly developing an application with a known working environment, to provide an evaluation platform, or as a control module for an applied system. Users should be familiar with memory mapping, memory types, and embedded software design for the quickest successful application development.

## Software Development

Application development maybe performed by applying the dBUG firmware monitor, or by applying a compatible ColdFire BDM / JTAG cable with supporting host software. The monitor provides an effective and low cost command line debug method.

Software development is best performed with a development tool connected to the BDM port. This provides real-time access to all hardware, peripherals and memory on the board. Development tool software also provides high-level (C/C++) source code debug environment.

The target development environment and procedure for best success is to place software to be tested into RAM memory. Execute software to be tested under dBUG monitor or development tool control. After the software is tested and operational in RAM, it can be ported and programmed into Flash memory. However, note that programming a bootable application into the internal Flash will overwrite the dBUG monitor. The monitor can be recovered by using a BDM Flash programming tool along with the dBUG binaries provided on the MCF5213 website (<http://www.freescale.com/coldfire>).

## Reference Documentation

The following documents should be referenced when developing with the M5213EVB. These documents are available on the MCF5213 and M5213EVB web pages (<http://www.freescale.com/coldfire>).

M5213EVBUM – This user manual.

MCF5213RM – MCF5213 Device Reference Manual

CFPRM – ColdFire Programmers Reference Manual with instruction set

M5213EVB\_SCH\_C – M5213EVB board schematics

## M5213EVB Startup

Follow these steps to connect and power on the board for the default dBUG monitor operation.

- 1) Carefully unpack the M5213EVB and observe ESD preventive measures while handling the M5213EVB development board.
- 2) Configure a virtual terminal program (such as HyperTerminal or Tera Term) for a direct connection to the PC COM port to be applied for serial communication with the M5213EVB. Set the baud rate to 19.2K baud, 8 data bits, 1 stop bit, and no parity. Software XON / XOFF flow control should be enabled for Flash memory support operations. Use the AxIDE '√' tool bar button to configure the COM port on the PC.
- 3) Connect the M5213EVB board UART0 / TERMINAL serial port connector to the host PC COM port with the provided 9 pin serial cable.
- 4) Apply power to the development board by installing the wall plug power supply between a wall outlet and the PWR Jack on the board. Set the ON / OFF switch to the ON position. The board voltage indicators should turn on at this time.
- 5) Observe the terminal window display for the dBUG monitor prompt. The prompt should be similar to the following:

```
External Reset
```

```
ColdFire MCF5213 on the M5213EVB
Firmware v4a.1b.1b (Built on May 13 2005 08:04:26)
Copyright 2005 Freescale Semiconductor, Inc.
```

```
Enter 'help' for help.
```

```
dBUG>
```

- 6) The board is ready to use now. See the dBUG monitor manual section for additional monitor information. If BDM / JTAG development port interfaced tools are to be applied, see the BDM PORT section of this manual for more details on installation.

## M5213EVB Hardware Configuration and Options

The M5213EVB board provides a basic development or evaluation platform for the MCF5213 microcontroller. Following are descriptions of the main components and options provided on the board.

### MEMORY

The EVB memory is the internal MCF5213 device SRAM and Flash memory. The MCF5213 provides 32K bytes of SRAM and 256K bytes of Flash memory internally. The dBUG monitor occupies the lower 80K bytes of the MCF5213 Flash memory and lower 8K bytes of the SRAM. Refer to the dBUG memory map for default memory locations.

## POWER SUPPLY

Unregulated DC input power is applied by external connection to the Power Jack or TB1 terminal block. The ON\_OFF switch controls the input supply. The EVB 3.3VDC regulator is protected from reverse voltage by diode D7 and current limited by fuse F1.

### *Power Jack*

The Power Jack provides the default power input to the board. The jack accepts a standard 2.0 ~ 2.1mm center barrel plug connector (positive voltage center) to provide the +VIN supply of +5 to +25 VDC (+9VDC typical).

+Volts, 2mm center

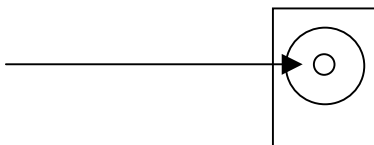

### *TB1 Power connection*

TB1 terminal block provides access to the +VIN and GND (power ground) supplies. The +VIN supply should be limited to the range of +5 to +25 VDC (+9VDC typical).

**TB1**

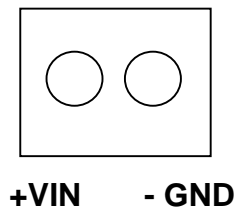

### *ON\_OFF Switch*

The ON\_OFF switch provides power On and Off control for the input power from the PWR Jack or TB1. Switch ON position is towards the PWR jack and OFF position is towards the TB1 connector.

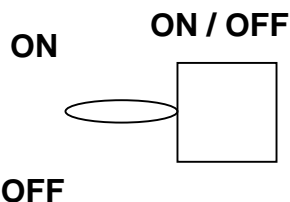

### *FUSE - F1*

Fuse F1 provides over current protection from PWR Jack or TB1 input to the EVB board. The fuse will open if current over 500mA is sustained or reaches 1 Amp. To reset the fuse, turn the



ON/OFF switch off or remove power for 10 minutes. Check for the cause of the over current condition before applying power again.

### *3.3V\_EN Option*

Default enabled by circuit trace across the option jumper pin pads, this option allows disabling the on board regulated 3.3VDC supply to the EVB board. Cut or idle this option to reduce current consumption when an external 3.3VDC regulated input voltage is applied from the EVB MCU PORT connector. See the VX\_EN option also for more details on applying external +3.3VDC on the MCU PORT.

To enable use of this option, cut the circuit trace between the mounting hole vias and install 1x2, 0.1"ctr, pin-header. A shunt must then be installed to enable this option.

### *3.3V Indicator*

The 3.3V indicator will be ON if voltage is applied to EVB +3.3VDC main supply circuit. If EVB is powered from the PWR jack or TB1 input, ON\_OFF switch is ON, and +3.3V\_EN is closed, this indicator should be ON. If not, remove power or turn EVB Off and verify connections. If the Fuse is suspect, see the F1 fuse section for reset procedure.

With the 3.3V\_EN option open, the indicator will be ON if external 3.3VDC is applied via the MCU Port. The VX\_EN option jumper should also be installed.

### *VDD and VRx Enable Options*

The EVB board provides many options to isolate power supplies to the different MCF5213 modules and core. All VDD and VRx options are installed by default. Do not operate the EVB without the proper power supplied to all of the MCF5213 power supply pins. The following table provides the VDD and VRx option information:

**VDD and VRx Option Table**

<b>Option Name</b>	<b>Supply Connection</b>	<b>MCU Port Connection</b>
VDD_EN	+3.3V to MCF5213 VDD pins	
VDD_PLL	+3.3V to MCF5213 VDDPLL pin	
VSTDBY	+3.3V to MCF5213 VSTDBY pin, also MCU Port connection	Pin 60
VDDA	+3.3V to MCF5213 VDDA analog supply pin, also MCU Port connection.	Pin 55
VRH	VDDA supply to MCF5213 VRH analog reference pin, also MCU Port	Pin 57
VRL	VSSA (ground) to MCF5213 VRL analog reference pin	VRL Pin 58, VSSA pin 56
VX_EN	MCU Port pin 1 connection to +3.3V supply, input or output. For input, see +3.3V_EN option also.	Pin 1

## *VX\_EN Option*

The VX\_EN option is provided to support external 3.3V input from the MCU PORT pin 1 in conjunction with Freescale educational accessories. The VX\_EN option installed provides external 3.3V input (or output if wanted) on MCU Port pin1.

See the 3.3V\_EN Option section above to disable the on-board regulator.

## **RESET**

External reset is provided by the RESET switch, LV1 low voltage detector, or user applied connection to the RSTI\* signal on the MCU PORT pin 6. If the main 3.3V supply is below operating level, the LV1 voltage detector will cause the MCF5213 to stay in the RESET condition. Both the RESET switch and LV1 provide a 150ms delay after release for the system to stabilize.

Application of RESET will cause the dBUG monitor or user application to initialize the MCF5213. The previous operating state of the MCF5213 will be lost.

### *RESET Switch*

RESET switch provides for manual application of the MCF5213 RSTI\* signal. Reset switch operation is provided a 150ms delay after release by LV1.

### *RESET Indicator*

RESET indicator will be ON for the duration of a valid RSTO\* signal. This operation indicates the MCF5213 is in the Reset state.

## **ABORT Switch**

The ABORT switch provides for manual application of the IRQ7 interrupt signal. This operation will allow the dBUG monitor to stop execution of a user program and maintain the CPU operating state for user examination.

## **SW1 and SW2 Switches**

User switches 1 and 2 are available for application as needed. Both switches provide an active low signal when pressed. SW1 applies the MCF5213 IRQ4 signal and SW2 applies the MCF5213 IRQ5 signal.

## **LED[4:1] User Indicators**

Four user indicators are provided for application on the MCF5213 DTIN[3:0] signals (configurable as GPIO). Indicators are buffered so they do not load the MCF5213 I/O port.

## Indicator Table

INDICATOR	COLOR	OPERATION	DEFAULT CONDITION
LED1	Green	MCF5213 DTIN0 status, high = ON	ON
LED2	Green	MCF5213 DTIN1 status, high = ON	ON
LED3	Green	MCF5213 DTIN2 status, high = ON	ON
LED4	Green	MCF5213 DTIN3 status, high = ON	ON

### *LED\_EN option*

The user LED indicators LED[4:1] must be enabled by the LED\_EN option installed.

## SYSTEM CLOCK

The EVB provides a 8MHz crystal oscillator reference input in Pierce Mode configuration. The MCF5213 also provides an internal 8MHz relaxation oscillator. The SMA connector position and socket X1 position are for factory testing purposes only and should not be applied.

**NOTE:** Applying alternate clock inputs without express consent from Axiom Manufacturing may void the user's authority to operate this equipment.

### *CLOCK Option Chart*

Clock Type		Clock Mode		CLK_SEL Option Setting					
Source	PLL	CLK0	CLK1	1	2	3	4	5	6
Y1 (8MHz)	ON	Out / Idle	Out / Idle	In	In	Out	NC	NC	NC
Y1 (8MHz)	OFF	Out / Idle	In	In	In	Out	NC	NC	NC
INT OSC	ON	In	Out / Idle	Out	Out	In	NC	NC	NC
INT OSC	OFF	In	In	Out	Out	In	NC	NC	NC

Notes:

- 1) INT OSC is the internal MCF5213 8MHz relaxation oscillator.
- 2) CLK\_SEL option has 2 option jumpers provided. For INT OSC selection idle one jumper on one pin so it will not be lost.
- 3) CLK\_SEL option positions 3-6 are for factory use only.

## UART0\_TERMINAL and UART1 Ports

The UART0\_TERMINAL port provides the primary interface to the dBUG monitor with a default baud rate of 19.2K baud, 8 data bits, 1 stop bit, and no parity. Both the UART0 and UART1 ports apply a standard 9-pin serial connector with RS232 type interface to the MCF5213 UART0 or UART1 serial ports. Both ports apply a UARTx\_EN option jumper block to enable the MCF5213 UART signals to operate the RS232 ports. A straight through DB9 Male / Female type serial cable can be applied to connect the ports to a standard PC COM port. Following is the DB9S connection reference.

### UART0\_TERMINAL and UART1 Ports

1	1		X	DB9 socket connector with RS232 signal levels.  <b>1,4,6 connected for status null to host</b>
TXD	2	6	6	
RXD	3	7	7 CTS	
4	4	8	8 RTS	
GND	5	9	9	

### UART0\_EN and UART1\_EN Options

OPTION Name	UART0_EN MCF5213 signal applied	UART1_EN MCF5213 signal applied
TX	UTXD0 output	UTXD1 output
RX	URXD0 input	URXD1 input
RTS	URTS0* output	URTS1* output
CTS	UCTS0* input	UCTS1* input

## UART2\_CAN Port

The UART2\_CAN port provides the UART2 RS232 serial port or the CAN network port. Selection of the port interface type is provided by the COM\_SEL option jumper block. Additional options provide MCF5213 signal connection to the selected interface transceiver for the port. The UART2\_EN option block enables the MCF5213 UART2 signals for RS232 operation and the CAN\_EN option block enables the MCF5213 CAN signals for CAN network operation. The CAN port also has a network termination option, CAN\_TERM and biasing components RCAN1 and RCAN2 (not populated).

A straight through DB9 Male / Female type serial cable can be applied to connect the UART2 port in RS232 COM mode to a standard PC COM port. CAN mode connection will require the cabling to be compatible to the network applied. Following is the DB9S connection reference:

### UART2\_CAN Port

CAN	RS232	DB9	RS232	CAN	DB9 socket connector.  <b>1,4,6 connected for RS232 status null to host</b>
4, 6 tie	4, 6 tie	1		CAN Signal	
CAN_LO	TXD	2	6	1, 4 tie	
GND	RXD	3	7	7 CTS	
1, 6 tie	1, 6 tie	4	8	8 RTS	
GND	GND	5	9	X	

### COM\_SEL Option

Selects UART2\_CAN Port connector type of interface between UART2 RS232 operation and CAN operation. All 3 positions should be set for the same selection, UART or CAN.

Position	UART option	DB9 Connection	CAN Option
1	CTS	Pin 7	CAN_HI
2	RXD	Pin 3	GND
3	TXD	Pin 2	CAN_LO

### *UART2\_EN option*

UART2\_EN applies the MCF5213 UART2 signals to the UART2 RS232 level transceiver for operation on the UART2\_CAN connector.

OPTION Name	UART2_EN MCF5213 signal applied
TX	UTXD2 output
RX	URXD2 input
RTS	URTS2* output
CTS	UCTS2* input

### *CAN Operation*

The MCF5213 FlexCAN signals CANRX and CANTX are the secondary operation of the MCF5213 I2C serial port signals SDA and SCL. User must enable the CAN signal operation on the MCF5213 I/O port during the FlexCAN initialization. The FlexCAN transmit and receive signals are connected to the CAN transceiver with the CAN\_EN option block. To apply I2C function on these signals the CAN\_EN options must be open or idle.

The CAN port provides the physical interface layer for the MCF5213 FlexCAN Controller Area Network version 2.0B peripheral. The FlexCAN transmit and receive signals are connected to a 3.3V CAN transceiver capable of 1M baud communication (SN65HVD230) with the CAN\_EN option block. Transceiver differential CAN network signals (CAN\_HI and CAN\_LO) are provided to the COM\_SEL option block for connection by the UART2\_CAN port connector.

The CAN transceiver has CAN signal drive control via the **RS** test pad on the development board. The RS signal is provided a 1K Ohm pull-down resistor for the maximum signal rate setting. User may refer to the SN65HVD230 data sheet and apply additional transmit signal control at the RS test pad.

Bias options RCAN1 and RCAN2 (SMT 0805 size, not populated) provide idle bias connections for the CAN network if required by the user.

### *CAN\_TERM*

Installs a 62 ohm termination between the CAN\_HI and CAN LO signals. Each end of a CAN network must be terminated for proper operation.

### *CAN\_EN option*

Enable MCF5213 CAN signals to the CAN transceiver with this option.

Position	MCF5213 Signal
TX	CANTX
RX	CANRX

## JP1 – I2C Pull-up Enable

This option jumper block provides the necessary 4.7K ohm pull-ups to +3.3V for the MCF5213 I2C serial port signals. MCF5213 I2C primary serial port signals SDA and SCL are multiplexed with the FlexCAN CANRX and CANTX signals, or secondary with the QSPICS0 and QSPI\_SCK signals. The JP1 jumper block provides for a pull-up for either set of signals.

### JP1

JP1 Position	MCF5213 Signal with Pull-up Applied
1	QSPI_SCK / I2C_SCL (I2C Secondary)
2	QSPI_CS0 / I2C_SDA (I2C Secondary)
3	CANTX / I2C_SCL (I2C Primary)
4	CANRX / I2C_SDA (I2C Primary)

## MC13192 ZIGBEE™ TRANSCEIVER

MC13192 peripheral is operated by the M5213EVB SMAC software package, M5213TestApp. The example software and documentation maybe downloaded from Freescale at [www.freescale.com/zigbee](http://www.freescale.com/zigbee). The M5213TestApp is configured to provide power output at 0dB.

### *ZIGBEE\_EN Option*

This option jumper enables the interface signals between the MCF5213 microcontroller and the MC13192 ZIGBEE capable transceiver. Following is the connection signal chart.

MCF5213 Signal	MC13192 Signal
QSPI_DIN (Input)	MISO
QSPI_DOUT (Output)	MOSI
QSPI_SCLK (Output)	SCLK
QSPI_CS2* (Output)	CE*
Port_PQS4 (Output)	RESET*
IRQ1* (Input)	IRQ*
Port_PUB2 (Output)	RXTXEN
Port_PUB3 (Output)	ATTN*
IRQ2* (Input)	GPIO1 / IDLE
IRQ3* (Input)	GPIO2 / V_CRC

### TX Power

The SMAC software package provided sets output transmit power to nominal (0dB). Further, the source code is clearly annotated to caution the user against increasing output power levels above nominal (0dB).

Increasing output transmit power levels will cause the board to radiate excessively in violation of FCC requirements. The user may decrease output power as needed or required by the end-user application.

**CAUTION:** The user **must not** increase the power output above nominal (0dB) for any reason, or at any time. Increasing power output will violate FCC approval for board operation.

### Z\_CLKOUT TP

This test pad provides access to the MC13192 Clock output signal.

## M5213EVB I/O Ports

### BDM\_PORT

The BDM PORT provides a standard ColdFire BDM / JTAG development port. The **BDM\_EN** option provides for the development port mode selection between BDM or JTAG. Option **JP2** provides for a special JTAG mode port configuration that is applied to defeat the MCF5213 flash security (if enabled) for bulk erasing.

#### Development Cable Installation

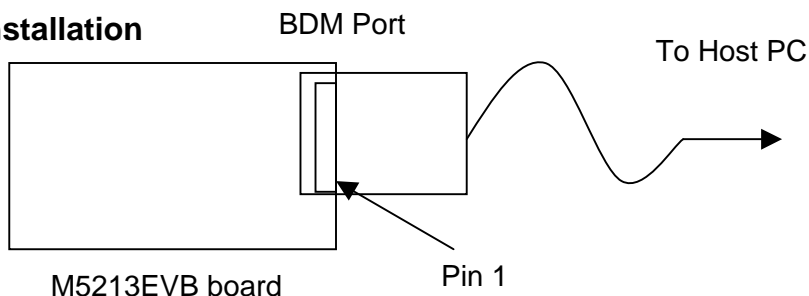

### BDM\_EN Option

The BDM\_EN option will select the development port mode at Reset.

Position	Development Port Mode
IN	BDM Mode (Default)
OUT	JTAG Mode

### *JP2 Option*

JP2 provides BDM port signal configuration option for BDM or Special JTAG mode. Special JTAG mode is applied for tools to defeat the MCF5213 flash security.

<b>Position</b>	<b>BDM Port Configuration</b>
1-2	BDM Mode (Default)
2-3	Special JTAG

### *BDM Port Connector*

	<b>1 2</b>	BKPT*
GND	<b>3 4</b>	DSCLK
GND	<b>5 6</b>	TCLK (From CT1 option)
RSTI*	<b>7 8</b>	DSI
+3.3V	<b>9 10</b>	DSO
GND	<b>11 12</b>	PST3
PST2	<b>13 14</b>	PST1
PST0	<b>15 16</b>	DDATA3
DDATA2	<b>17 18</b>	DDATA1
DDATA0	<b>19 20</b>	GND
	<b>21 22</b>	
GND	<b>23 24</b>	TCLK and CLKOUT Test Pad
+3.3V	<b>25 26</b>	TA* Test Pad



# MCU\_PORT

The MCU PORT provides user access to the MCF5213 I/O ports.

VX	1	2	IRQ1*
GND / VSS	3	4	RST0*
UTXD1	5	6	RST1*
URXD1	7	8	IRQ2*
URTS1	9	10	AN0
UCTS1	11	12	AN1
PWM1	13	14	AN2
PWM3	15	16	AN3
QSPI_DOUT	17	18	AN4
QSPI_DIN	19	20	AN5
QSPI_SCK	21	22	AN6
QSPI_CS0	23	24	AN7
QSPI_CS1	25	26	CANTX
QSPI_CS2	27	28	CANRX
QSPI_CS3	29	30	PWM5
IRQ3*	31	32	PWM7
IRQ4*	33	34	DTIN0
IRQ5*	35	36	DTIN1
IRQ6*	37	38	DTIN2
IRQ7*	39	40	DTIN3
UTXD0	41	42	URTS0*
URXD0	43	44	UCTS0*
UTXD2	45	46	URTS2*
URXD2	47	48	UCTS2*
GPT0	49	50	GPT1
GPT2	51	52	GPT3
RCON*	53	54	GND
VDDA	55	56	VSSA
VRH	57	58	VRL
+3.3V	59	60	VSTDBY

# TROUBLESHOOTING

The M5213EVB is fully tested and operational before shipping. If it fails to function properly, inspect the board for obvious physical damage first. Verify the communications setup as described under GETTING STARTED.

The most common problems are improperly configured options or communications parameters.

1. Verify default option settings and RESET the board.
2. Make sure that the RSTI\* line is not being held low or the RESET indicator is not on constantly.
3. Verify that your COM communications port is working by substituting a known good serial device or by doing a loop back diagnostic. If you applied a different baud rate with the dBUG SET command, make sure the terminal software is set correctly.
4. Verify the power source, +3.3V, indicator is ON? You should measure a minimum of 9 volts between the GND and +V test pad and GND test pad near the power jack with the standard power supply provided.
5. If no power indications or voltage is found, verify the wall plug connections to AC outlet and the PWR jack power connector.
6. Disconnect all external connections to the board except for COM1 to the PC and the wall plug and check operation again.
7. If applying a BDM or JTAG cable on the BDM Port, make sure the BDM\_EN option is properly set.
8. Ensure that the BKPT\* line is not being asserted by an active BDM interface cable applied to the BDM connector.
9. Contact [support@axman.com](mailto:support@axman.com) by email for further assistance. Provide board name and describe problem.

# dBUG MONITOR OPERATION

dBUG is a firmware resident development environment operated by the ColdFire processor as a primary control program. The monitor provides serial communication for loading and controlling the execution of software under test. User should note that the monitor occupies the first or lower address 80K bytes of the internal Flash memory. The monitor operates the MCF5213 with Y1 as the default clock and an internal frequency of 80Mhz.

## dBUG Communication:

Primary user interface to the dBUG monitor is by command lines that are entered into the serial port. These commands are defined in the following table “dBUG Commands”. For serial communications, dBUG requires eight data bits, no parity, and one stop bit, 8N1 with XON/XOFF soft flow control. The default baud rate is 19200; however, this rate can be changed by the user with a “set” command. The command line prompt is “dBUG> “. Any dBUG command may be entered from this prompt. dBUG does not allow command lines to exceed 80 characters. Wherever possible, dBUG displays data in 80 columns or less. dBUG echoes each character as it is typed, eliminating the need for any “local echo” on the terminal side. In general, dBUG is not case sensitive. Commands may be entered in either upper or lower case, depending upon the user’s equipment and preference. Only symbol names require that the exact case be used.

## dBUG System Initialization

The act of powering up the board will initialize the system. The processor is reset and dBUG is invoked. dBUG performs the following configurations of internal resources during the initialization:

Internal memories are mapped as described in the dBUG memory map section below.

The MCF5213 PLL is initialized to multiply the default 8MHz input reference up to 80 MHz.

All volatile code sections and the interrupt vector table are copied from ROM to RAM.

Control is given to the user via the command prompt.

### *Interrupt Service Support*

The Vector Base Register, VBR, is programmed to point to the RAM copy of the vector table at the base of the internal SRAM. To take over an exception vector, the user places the address of the exception handler in the appropriate vector in the vector table.

## dBUG Memory Map

The following table shows the dBUG memory map. This information is also provided via the ‘mmap’ dBUG command.

0x00000000	Internal 256KByte Flash Memory dBUG protected code
0x00013FFF	80KBytes
0x00014000	Internal 256KByte Flash Memory User space
0x0003FFFF	176KBytes
0x20000000	Internal 32KByte SRAM Memory Vector Table and dBUG protected data
0x20001FFF	8KBytes
0x20002000	Internal 32KByte SRAM Memory User space
0x20007FFF	24KBytes

Note: Applying BDM / JTAG development port tools does not require following the dBUG memory map.

## dBUG Commands

After the system initialization, the dBUG waits for a command-line input from the user terminal. When a proper command is entered, the operation continues in one of the two basic modes. If the command causes execution of the user program, the dBUG firmware may or may not be re-entered, at the discretion of the user's program. For the alternate case, the command will be executed under control of the dBUG firmware, and after command completion, the system returns to command entry mode.

### *dBUG Command Table*

<b>MNEMONIC</b>	<b>SYNTAX</b>	<b>DESCRIPTION</b>
ASM	asm <<addr> <assembly>>	Assemble
BC	bc addr1 addr2 length	Block Compare
BF	bf <width> begin end data <inc>	Block Fill
BM	bm begin end dest	Block Move
BR	br addr <-r> <-c count> <-t trigger>	Breakpoint
BS	bs <width> begin end data	Block Search
DC	dc value	Data Convert
DI	di <addr>	Disassemble
DL	dl <offset>	Download Serial
DLDEBUG	dldbug	Download dBUG Update
FL	fl <command> dest <src> size	Flash write or erase
GO	go <addr>	Execute
GT	gt addr	Execute To
HELP	help <command>	Help
IRD	ird <module.register> Internal	Internal Register Display

IRM	irm module.register data	Internal Register Modify
LR	lr <width> addr	Loop Read
LW	lw <width> addr data	Loop Write
MD	md <width> <begin> <end>	Memory Display
MM	mm <width> addr <data>	Memory Modify
MMAP	mmap	Memory Map Display
RD	rd <reg>	Register Display (core)
RM	rm reg data	Register Modify (core)
RESET	reset	Reset
SD	sd	Stack Display (contents)
SET	set <option value>	Set Configurations
SHOW	show <option>	Show Configurations
STEP	step	Step (Over)
SYM	symbol <symp> <-a symp value> <-r symp> <-C I S>	Symbol Management
TRACE	trace <num>	Trace (Into)
VER	version	Show dBUG Version

During command execution, additional user input may be required depending on the command function. For commands that accept an optional <width> to modify the memory access size, the valid values are:

- B = 8-bit (byte) access
- W = 16-bit (word) access
- L = 32-bit (long) access

When no <width> option is provided, the default width is “W”, 16-bit.

The core ColdFire register set is maintained by dBUG. These are listed below:

- A0 - A7
- D0 - D7
- PC
- SR

All control registers on ColdFire are not readable by the supervisor-programming model, and thus not accessible via dBUG. User code may change these registers, but caution must be exercised as changes may render dBUG inoperable. A reference to “SP” (stack pointer) actually refers to general purpose address register seven, “A7.”

The commands DI, GO, MD, STEP, and TRACE are used repeatedly when debugging. dBUG recognizes this and allows for repeated execution of these commands with minimal typing. After a command is entered, simply press <RETURN> or <ENTER> to invoke the command again. The command is executed as if no command line parameters were provided.

User programs are provided access to various dBUG routines by the “Trap 15 Functions”. These functions are discussed at the end of this chapter.

# Appendix 1: dBUG Command Set

Note that arguments used in the command examples (such as addresses) are chosen arbitrarily and will not be valid on all ColdFire EVBs.

## ASM - Assembler

**Usage:**     **ASM <<addr> <assembly>>**

The ASM command is a primitive assembler. The **<assembly>** is assembled and the resulting code placed at **<addr>**. This command has an interactive and non-interactive mode of operation.

The value for address **<addr>** may be an absolute address specified as a hexadecimal value, or a symbol name. The value for **stmt** must be valid assembler mnemonics for the CPU.

For the interactive mode, the user enters the command and the optional **<addr>**. If the address is not specified, then the last address is used. The memory contents at the address are disassembled, and the user prompted for the new assembly. If valid, the new assembly is placed into memory, and the address incremented accordingly. If the assembly is not valid, then memory is not modified, and an error message produced. In either case, memory is disassembled and the process repeats.

The user may press the **<Enter>** or **<Return>** key to accept the current memory contents and skip to the next instruction, or enter a period (".") to quit the interactive mode.

In the non-interactive mode, the user specifies the address and the assembly statement on the command line. The statement is assembled, and if valid, placed into memory, otherwise an error message is produced.

### Examples:

To place a NOP instruction at address 0x2000\_2000, the command is:

```
asm 20002000 nop
```

To interactively assembly memory at address 0x2000\_20000, the command is:

```
asm 20002000
```

## BC - Block Compare

**Usage:**     **BC addr1 addr2 length**

The BC command compares two contiguous blocks of memory on a byte by byte basis. The first block starts at address **addr1** and the second starts at address **addr2**, both of **length** bytes.

If the blocks are not identical, the address of the first mismatch is displayed. The value for addresses **addr1** and **addr2** may be an absolute address specified as a hexadecimal value or

a symbol name. The value for length may be a symbol name or a number converted according to the user defined radix (hexadecimal by default).

**Example:**

To verify that the data starting at 0x20000 and ending at 0x3\_0000 is identical to the data starting at 0x8\_0000, the command is:

```
bc 20000 80000 10000
```

## BF - Block Fill

**Usage:**      **BF<width> begin end data <inc>**

The BF command fills a contiguous block of memory starting at address **begin**, stopping at address **end**, with the value **data**. **<Width>** modifies the size of the data that is written. If no **<width>** is specified, the default of word sized data is used.

The value for addresses begin and end may be an absolute address specified as a hexadecimal value, or a symbol name. The value for data may be a symbol name, or a number converted according to the user-defined radix, normally hexadecimal.

The optional value **<inc>** can be used to increment (or decrement) the data value during the fill.

This command first aligns the starting address for the data access size, and then increments the address accordingly during the operation. Thus, for the duration of the operation, this command performs properly-aligned memory accesses.

**Examples:**

To fill a memory block starting at 0x2\_0000 and ending at 0x4\_0000 with the value 0x1234, the command is:

```
bf 20000 40000 1234
```

To fill a block of memory starting at 0x20000 and ending at 0x4\_0000 with a byte value of 0xAB, the command is:

```
bf.b 20000 40000 AB
```

To zero out the BSS section of the target code (defined by the symbols `bss_start` and `bss_end`), the command is:

```
bf bss_start bss_end 0
```

To fill a block of memory starting at 0x2\_0000 and ending at 0x4\_0000 with data that increments by 2 for each **<width>**, the command is:

```
bf 20000 40000 0 2
```

## BM - Block Move

**Usage:**        **BM begin end dest**

The BM command moves a block of memory starting at address **begin** and stopping at address **end** to the new address **dest**. The BM command copies memory as a series of bytes, and does not alter the original block.

The values for addresses begin, end, and dest may be absolute addresses specified as hexadecimal values, or symbol names. If the destination address overlaps the block defined by begin and end, an error message is produced and the command exits.

### Examples:

To copy a block of memory starting at 0x4\_0000 and ending at 0x7\_0000 to the location 0x200000, the command is:

```
bm 40000 70000 200000
```

To copy the target code's data section (defined by the symbols data\_start and data\_end) to 0x200000, the command is:

```
bm data_start data_end 200000
```

**NOTE:** Refer to "upuser" command for copying code/data into Flash memory.

## BR - Breakpoints

**Usage:**        **BR addr <-r> <-c count> <-t trigger>**

The BR command inserts or removes breakpoints at address **addr**. The value for addr may be an absolute address specified as a hexadecimal value, or a symbol name. Count and trigger are numbers converted according to the user-defined radix, normally hexadecimal.

If no argument is provided to the BR command, a listing of all defined breakpoints is displayed.

The **-r** option to the BR command removes a breakpoint defined at address addr. If no address is specified in conjunction with the **-r** option, then all breakpoints are removed.

Each time a breakpoint is encountered during the execution of target code, its count value is incremented by one. By default, the initial count value for a breakpoint is zero, but the **-c** option allows setting the initial count for the breakpoint.

Each time a breakpoint is encountered during the execution of target code, the count value is compared against the trigger value. If the count value is equal to or greater than the trigger value, a breakpoint is encountered and control returned to **dBUG**. By default, the initial trigger value for a breakpoint is one, but the **-t** option allows setting the initial trigger for the breakpoint.

If no address is specified in conjunction with the **-c** or **-t** options, then all breakpoints are initialized to the values specified by the **-c** or **-t** option.



**Examples:**

To set a breakpoint at the C function `main()` (symbol `_main`; see “symbol” command), the command is:

```
br _main
```

When the target code is executed and the processor reaches `main()`, control will be returned to **dBUG**.

To set a breakpoint at the C function `bench()` and set its trigger value to 3, the command is:

```
br _bench -t 3
```

When the target code is executed, the processor must attempt to execute the function `bench()` a third time before returning control back to **dBUG**.

To remove all breakpoints, the command is:

```
br -r
```

## BS - Block Search

**Usage:**      **BS<width> begin end data**

The BS command searches a contiguous block of memory starting at address **begin**, stopping at address **end**, for the value **data**. **<Width>** modifies the size of the data that is compared during the search. If no **<width>** is specified, the default of word sized data is used.

The values for addresses **begin** and **end** may be absolute addresses specified as hexadecimal values, or symbol names. The value for **data** may be a symbol name or a number converted according to the user-defined radix, normally hexadecimal.

This command first aligns the starting address for the data access size, and then increments the address accordingly during the operation. Thus, for the duration of the operation, this command performs properly-aligned memory accesses.

**Examples:**

To search for the 32-bit value `0x1234_5678` in the memory block starting at `0x4_0000` and ending at `0x7_0000`:

```
bs.l 40000 70000 12345678
```

This reads the 32-bit word located at `0x0004_0000` and compares it against the 32-bit value `0x1234_5678`. If no match is found, then the address is incremented to `0x0004_0004` and the next 32-bit value is read and compared.

To search for the 16-bit value `0x1234` in the memory block starting at `0x0004_0000` and ending at `0x0007_0000`:

```
bs 40000 70000 1234
```

This reads the 16-bit word located at 0x4\_0000 and compares it against the 16-bit value 0x0000\_1234. If no match is found, then the address is incremented to 0x0004\_0002 and the next 16-bit value is read and compared.

## DC - Data Conversion

**Usage:**      **DC data**

The DC command displays the hexadecimal or decimal value **data** in hexadecimal, binary, and decimal notation.

The value for data may be a symbol name or an absolute value. If an absolute value passed into the DC command is prefixed by '0x', then data is interpreted as a hexadecimal value. Otherwise data is interpreted as a decimal value.

All values are treated as 32-bit quantities.

### Examples:

To display the decimal and binary equivalent of 0x1234, the command is:

```
dc 0x1234
```

To display the hexadecimal and binary equivalent of 1234, the command is:

```
dc 1234
```

## DI - Disassemble

**Usage:**      **DI <addr>**

The DI command disassembles target code pointed to by **addr**. The value for addr may be an absolute address specified as a hexadecimal value, or a symbol name.

Wherever possible, the disassembler will use information from the symbol table to produce a more meaningful disassembly. This is especially useful for branch target addresses and subroutine calls.

The DI command attempts to track the address of the last disassembled opcode. If no address is provided to the DI command, then the DI command uses the address of the last opcode that was disassembled.

The DI command is repeatable.

### Examples:

To disassemble code that starts at 0x0004\_0000, the command is:

```
di 40000
```

To disassemble code of the C function main(), the command is:

```
di    _main
```

## DL - Download Console

**Usage:** DL <offset>

The DL command performs an S-record download of data obtained from the console or serial port. The value for offset is converted according to the user-defined radix, normally hexadecimal.

If **offset** is provided, then the destination address of each S-record is adjusted by offset.

The DL command checks the destination download address for validity. If the destination is an address outside the defined user space, then an error message is displayed and downloading aborted.

If the destination address is in the user flash memory space, the flash will be programmed but not erased. See the FL command for flash erasing.

If the S-record file contains the entry point address, then the program counter is set to reflect this address.

### Examples:

To download an S-record file through the serial port, the command is:

```
dl
```

To download an S-record file through the serial port, and add an offset to the destination address of 0x40000, the command is:

```
dl    0x40000
```

After the DL command is invoked, the user should select file transfer or upload and send the S-record file from the host. The host serial terminal software should apply XON/XOFF flow control to the transfer if the target memory is Flash space to allow flash programming time delays. Alternate method is to download with an offset into SDRAM memory space and then apply the FL command to program the flash memory space.

## DLDEBUG – Download dBUG (update)

**Usage:** dldebug

The dldebug command is used to update the dBUG image in Flash memory. When updates to the M5213EVB dBUG are available, the update S-record may be downloaded into the Flash from the console or serial port similar to the DL command. The user is prompted for verification before performing the operation (note case sensitivity here). XON/XOFF serial flow control must be applied when loading the new S-record. Use this command with extreme caution, as any error can render dBUG useless!

## FL – Flash Load or Erase

**Usage:** FL <command> dest <src> <size>

The FL command is used to erase and write the MCF5213 internal flash, and display flash device information. Erase or write operations must be performed in even page sizes. The write command will erase all of the associated flash pages prior to writing. If the write destination address or byte count range does not provide an even page boundary, dBUG will prompt the user to continue.

The MCF5213 internal flash destination address must be long word (4 byte) aligned and the byte count must be in longword (4 byte) multiples.

To download S-record files directly into the flash, please see the DL command.

### Examples:

To view the flash device sector information, the command is:

```
fl
```

To erase 0x10000 (64K) bytes of internal flash starting at 0xF0000000, the command is:

```
fl e F0000000 10000
```

To copy 0x4000 (16K) bytes of data from SRAM (0x20000000) to flash at 0x00020000, the command is:

```
fl w 00020000 20000000 4000
```

## GO – Execute user code

**Usage:** GO <addr>

The GO command executes target code starting at address **addr**. The value for addr may be an absolute address specified as a hexadecimal value, or a symbol name.

If no argument is provided, the GO command begins executing instructions at the current program counter.

When the GO command is executed, all user-defined breakpoints are inserted into the target code, and the context is switched to the target program. Control is only regained when the target code encounters a breakpoint, illegal instruction, or other exception that causes control to be handed back to **dBUG**.

The GO command is repeatable.

### Examples:

To execute code at the current program counter, the command is:

```
go
```

To execute code at the C function `main()`, the command is:

```
go _main
```

To execute code at the address `0x00040000`, the command is:

```
go 40000
```

## GT - Execute To Address

**Usage:**      **GT addr**

The GT command inserts a temporary software breakpoint at **addr** and then executes target code starting at the current program counter. The value for **addr** may be an absolute address specified as a hexadecimal value, or a symbol name.

When the GT command is executed, all breakpoints are inserted into the target code, and the context is switched to the target program. Control is only regained when the target code encounters a breakpoint, illegal instruction, or an exception which causes control to be handed back to **dBUG**.

### Examples:

To execute code up to the C function `bench()`, the command is:

```
gt _bench
```

To execute code up to the address `0x00080004`, the command is:

```
gt 80004
```

## IRD - Internal Register Display

**Usage:**      **IRD <module.register>**

This command displays the internal registers of the different modules inside the MCF5213. In the command line, **module** refers to the module name where the register is located and **register** refers to the specific register to display.

The registers are organized according to the module to which they belong. Refer to the MCF5213 user's manual for information on these modules and the registers they contain.

### Example:

```
ird uart0.umar1
```

```
ird uart0
```

## IRM - Internal Register Modify

**Usage:**      **IRM module.register data**

This command modifies the contents of the internal registers of different modules inside the MCF5213. In the command line, module refers to the module name where the register is located and register refers to the specific register to modify. The data parameter specifies the new value to be written into the register.

The registers are organized according to the module to which they belong. Refer to the MCF5213 user's manual for information on these modules and the registers they contain.

## HELP - Help

**Usage:**        **HELP <command>**

The HELP command displays a brief syntax of the commands available within **dBUG**. In addition, the address of where user code may start is given. If command is provided, then a brief listing of the syntax of the specified command is displayed.

### Examples:

To obtain a listing of all the commands available within **dBUG**, the command is:

```
help
```

To obtain help on the breakpoint command, the command is:

```
help br
```

## LR - Loop Read

**Usage:**        **LR <width> addr**

The LR command continually reads the data at **addr** until a key is pressed. The optional **<width>** specifies the size of the data to be read. If no **<width>** is specified, the command defaults to reading word sized data.

### Example:

To continually read the word data from address 0xFFF2\_0000, the command is:

```
lr FFF20000
```

## LW - Loop Write

**Usage:**        **LW <width> addr data**

The LW command continually writes data to **addr**. The optional width specifies the size of the access to memory. The default access size is a word.

### Examples:

To continually write the data 0x1234\_5678 to address 0x0002\_0000, the command is:

```
lw.l 20000 12345678
```

Note that the following command writes 0x78 into memory:

```
lw.b 20000 78
```

## MD - Memory Display

**Usage:**      **MD <width> <begin> <end>**

The MD command displays a contiguous block of memory starting at address **begin** and stopping at address **end**. The values for addresses **begin** and **end** may be absolute addresses specified as hexadecimal values, or symbol names. Width modifies the size of the data that is displayed. If no **<width>** is specified, the default of word sized data is used.

Memory display starts at the address **begin**. If no beginning address is provided, the MD command uses the last address that was displayed. If no ending address is provided, then MD will display memory up to an address that is 128 beyond the starting address.

This command first aligns the starting address for the data access size, and then increments the address accordingly during the operation. Thus, for the duration of the operation, this command performs properly-aligned memory accesses.

### Examples:

To display memory at address 0x0040\_0000, the command is:

```
md 400000
```

To display memory in the data section (defined by the symbols **data\_start** and **data\_end**), the command is:

```
md data_start
```

To display a range of bytes from 0x00040000 to 0x0005\_0000, the command is:

```
md.b 40000 50000
```

To display a range of 32-bit values starting at 0x0004\_0000 and ending at 0x0005\_0000:

```
md 40000 50000
```

## MM - Memory Modify

**Usage:**      **MM<width> addr <data>**

The MM command modifies memory at the address **addr**. The value for **addr** may be an absolute address specified as a hexadecimal value, or a symbol name. Width specifies the size of the data that is modified. If no **<width>** is specified, the default of word sized data is used. The value for **data** may be a symbol name, or a number converted according to the user-defined radix, normally hexadecimal.

If a value for data is provided, then the MM command immediately sets the contents of addr to data.

If no value for data is provided, then the MM command enters into a loop. The loop obtains a value for data, sets the contents of the current address to data, increments the address according to the data size, and repeats. The loop terminates when an invalid entry for the data value is entered, for instance a period '.'.

This command first aligns the starting address for the data access size, and then increments the address accordingly during the operation. Thus, for the duration of the operation, this command performs properly-aligned memory accesses.

### Examples:

To set the byte at location 0x0001\_0000 to be 0xFF, the command is:

```
mm.b 10000 FF
```

To interactively modify memory beginning at 0x0001\_0000, the command is:

```
mm 10000
```

## MMAP - Memory Map Display

**Usage:**     **mmap**

This command displays the memory map information for the evaluation board. The information displayed includes the type of memory, the start and end address of the memory, and the port size of the memory. The display also includes information on how the Chip-selects are used on the board.

Here is an example of the output from this command:

Type	Start	End
SRAM	0x20000000	0x20007FFF
IPSBAR	0x40000000	0x7FFFFFFF
Flash	0x00000000	0x0003FFFF
-----		
Protected	Start	End
dBUG Code	0x00000000	0x00011FFF
dBUG Data	0x20000000	0x20001FFF

## RD - Register Display

**Usage:**     **RD <reg>**

The RD command displays the register set of the target. If no argument for **reg** is provided, then all registers are displayed. Otherwise, the value for reg is displayed.



**dBUG** preserves the registers by storing a copy of the register set in a buffer. The RD command displays register values from the register buffer.

### Examples:

To display only the program counter:

```
rd pc
```

To display all the registers and their values, the command is:

```
rd
```

Here is an example of the output from this command:

```
PC: 00000000 SR: 2000 [t.Sm.000...xnzvc]
```

```
An: 00000000 00000000 00000000 00000000 00000000 00000000 00000000 01000000
```

```
Dn: 00000000 00000000 00000000 00000000 00000000 00000000 00000000 00000000
```

## RM - Register Modify

**Usage:**      **RM reg data**

The RM command modifies the contents of the register **reg** to data. The value for reg is the name of the register, and the value for data may be a symbol name, or it is converted according to the user-defined radix, normally hexadecimal.

**dBUG** preserves the registers by storing a copy of the register set in a buffer. The RM command updates the copy of the register in the buffer. The actual value will not be written to the register until target code is executed.

### Example:

To change program counter to contain the value 0x2000\_8000, the command is:

```
rm pc 20008000
```

## RESET - Reset the Board and dBUG

**Usage:**      **RESET**

The RESET command resets the board and **dBUG** to their initial power-on states.

The RESET command executes the same sequence of code that occurs at power-on. If the RESET command fails to reset the board properly, cycle the power or press the RESET button.

### Examples:

To reset the board and clear the **dBUG** data structures, the command is:

reset

## SET - Set Configurations

**Usage:**        **SET <option value>**

The SET command allows the setting of user-configurable options within **dBUG**. With no arguments, SET displays the options and values available. The SHOW command displays the settings in the appropriate format. Note that some configuration items will not take effect until a Reset has occurred. The standard set of options is listed below.

**baud** - This is the baud rate for the first serial port on the board. All communications between **dBUG** and the user occur using 19200 bps, eight data bits, no parity, and one stop bit, 8N1, with no flow control.

**base** - This is the default radix for use in converting a number from its ASCII text representation to the internal quantity used by **dBUG**. The default is hexadecimal (base 16), and other choices are binary (base 2), octal (base 8), and decimal (base 10).

### Examples:

To set the baud rate of the board to be 38400, the command is:

```
set baud 38400
```

**NOTE:** See the SHOW command for a display containing the correct formatting of these options.

## SHOW - Show Configurations

**Usage:**        **SHOW <option>**

The SHOW command displays the settings of the user-configurable options within **dBUG**. When no option is provided, SHOW displays all options and values.

### Examples:

To display the current baud rate of the board, the command is:

```
show baud
```

To display all options and settings, the command is:

```
show
```

Here is an example of the output from a show command:

```
dBUG> show
      base: 16
      baud: 19200
```

## STEP - Step Over

**Usage:**        **STEP**

The STEP command can be used to “step over” a subroutine call, rather than tracing every instruction in the subroutine. The ST command sets a temporary software breakpoint one instruction beyond the current program counter and then executes the target code.

The STEP command can be used to “step over” BSR and JSR instructions.

The STEP command will work for other instructions as well, but note that if the STEP command is used with an instruction that will not return, i.e. BRA, then the temporary breakpoint may never be encountered and **dBUG** may never regain control.

**Examples:**

To pass over a subroutine call, the command is:

```
step
```

## SYMBOL - Symbol Name Management

**Usage:**        **SYMBOL <symp> <-a symp value> <-r symp> <-c||s>**

The SYMBOL command adds or removes **symbol** names from the symbol table. If only a symbol name is provided to the SYMBOL command, then the symbol table is searched for a match on the symbol name and its information displayed.

**-a** option adds a symbol name and its value into the symbol table.

**-r** option removes a symbol name from the table.

**-c** option clears the entire symbol table.

**-l** option lists the contents of the symbol table.

**-s** option displays usage information for the symbol table.

Symbol names contained in the symbol table are truncated to 31 characters. Any symbol table lookups, either by the SYMBOL command or by the assembler/disassembler, will only use the first 31 characters. Symbol names are case-sensitive.

Symbols can also be added to the symbol table via in-line assembly labels and Ethernet downloads of ELF formatted files.

**Examples:**

To define the symbol “main” to have the value 0x0004\_0000, the command is:

```
symbol -a main 40000
```

To remove the symbol “junk” from the table, the command is:

symbol -r junk

To see how full the symbol table is, the command is:

symbol -s

To display the symbol table, the command is:

symbol -l

## TRACE - Trace Into

**Usage:** TRACE <num>

The TRACE command allows single-instruction execution. If **num** is provided, then num instructions are executed before control is handed back to **dBUG**. The value for num is a decimal number.

The TRACE command sets bits in the processors' supervisor registers to achieve single-instruction execution, and the target code executed. Control returns to **dBUG** after a single-instruction execution of the target code.

This command is repeatable.

### Examples:

To trace one instruction at the program counter, the command is:

tr

To trace 20 instructions from the program counter, the command is:

tr 20

## VERSION - Display dBUG Version

**Usage:** VERSION

The VERSION command displays the version information for **dBUG**. The **dBUG** version, build number and build date are all given.

The version number is separated by a decimal, for example, "v 2b.1c.1a".

The version date is the day and time at which the entire **dBUG** monitor was compiled and built.

### Examples:

To display the version of the **dBUG** monitor, the command is:

ver

## TRAP #15 Functions

An additional utility within the dBUG firmware is a function called the TRAP 15 handler. This function can be called by the user program to utilize various routines within the dBUG, perform a special task, and to return control to the dBUG. This section describes the TRAP 15 handler and how it is used.

There are four TRAP #15 functions. These are: **OUT\_CHAR**, **IN\_CHAR**, **CHAR\_PRESENT**, and **EXIT\_TO\_dBUG**.

### *OUT\_CHAR*

This function (function code 0x0013) sends a character, which is in lower 8 bits of D1, to terminal. Assembly example:

```
/* assume d1 contains the character */
    move.l          #$0013,d0    Selects the function
    TRAP           #15          The character in d1 is sent to terminal
```

#### C example:

```
void board_out_char (int ch)
{
    /* If your C compiler produces a LINK/UNLK pair for this routine,
     * then use the following code which takes this into account
     */
    #if 1
        /* LINK a6,#0      -- produced by C compiler */
        asm (" move.l 8(a6),d1");          /* put `ch` into d1 */
        asm (" move.l #0x0013,d0");      /* select the function */
        asm (" trap #15");                /* make the call */
        /* UNLK a6        -- produced by C compiler */
    #else
        asm (" move.l 4(sp),d1");          /* put `ch` into d1 */
        asm (" move.l #0x0013,d0");      /* select the function */
        asm (" trap #15");                /* make the call */
    #endif
}
```

### *IN\_CHAR*

This function (function code 0x0010) returns an input character (from terminal) to the caller. The returned character is in D1.

#### Assembly example:

```
    move.l          #$0010,d0    Select the function
    trap           #15          Make the call, the input character is in d1.
```

#### C example:

```
int board_in_char (void)
{
    asm (" move.l #0x0010,d0"); /* select the function */
    asm (" trap #15");          /* make the call */
    asm (" move.l d1,d0");     /* put the character in d0 */
}
```

## *CHAR\_PRESENT*

This function (function code 0x0014) checks if an input character is present to receive. A value of zero is returned in D0 when no character is present. A non-zero value in D0 means a character is present.

### Assembly example:

```
move.l    #$0014,d0      Select the function
trap     #15             Make the call, d0 contains the result
```

### C example:

```
int board_char_present (void)
{
    asm (" move.l #0x0014,d0"); /* select the function */
    asm (" trap #15");          /* make the call */
}
```

## *EXIT\_TO\_dBUG*

This function (function code 0x0000) transfers the control back to the dBUG, by terminating the user code. The register contents are preserved.

### Assembly example:

```
move.l    #$0000,d0      Select the function
trap     #15             Make the call,  exit to dBUG.
```

### C example:

```
void board_exit_to_dbug (void)
{
    asm (" move.l #0x0000,d0"); /* select the function */
    asm (" trap #15");          /* exit and transfer to dBUG */
}
```