

Fact Sheet

MC44C800/MC44C801
SILICON TUNER

SINGLE-CHIP CMOS
BROADBAND TUNER

OVERVIEW

The silicon tuner is at the heart of broadband applications, and Motorola's products, the MC44C800 and the MC44C801, offer a cost-effective, high-performance "cable tuner-on-a-chip." These silicon tuner ICs are highly integrated, single-chip broadband tuners. The parts are fabricated in a low-cost CMOS process. They receive 54 MHz to 861 MHz cable signals and convert them to a second IF of 36 MHz to 46 MHz.

Typical applications for the MC44C800 and the MC44C801 include cable data modems, cable digital and analog set-top boxes, and VoIP telephony boxes. These tuners are designed to meet all DOCSIS™ 1.1 specs for 64 and 256 quadrature amplitude modulation (QAM).

These single-chip broadband tuners use a double conversion architecture with an external first IF SAW filter at 1120 MHz. The double conversion architecture replaces the front-end tracking filters and their manually aligned coils with an inexpensive fixed-frequency SAW filter at 1120 MHz. Both versions are identical, with the exception of the low-noise amplifier (LNA). The MC44C801 has a bus-programmable variable gain LNA with 21 dB of gain control. The MC44C800 has a fixed gain LNA and combines with an external pin diode attenuator to provide analog variable gain control.

APPLICATIONS

- Cable Set-Top Boxes
- Cable Modems
- Televisions
- VCRs
- Personal Video Recorders
- VoIP Telephony Boxes



**For More Information On This Product,
Go to: www.freescale.com**

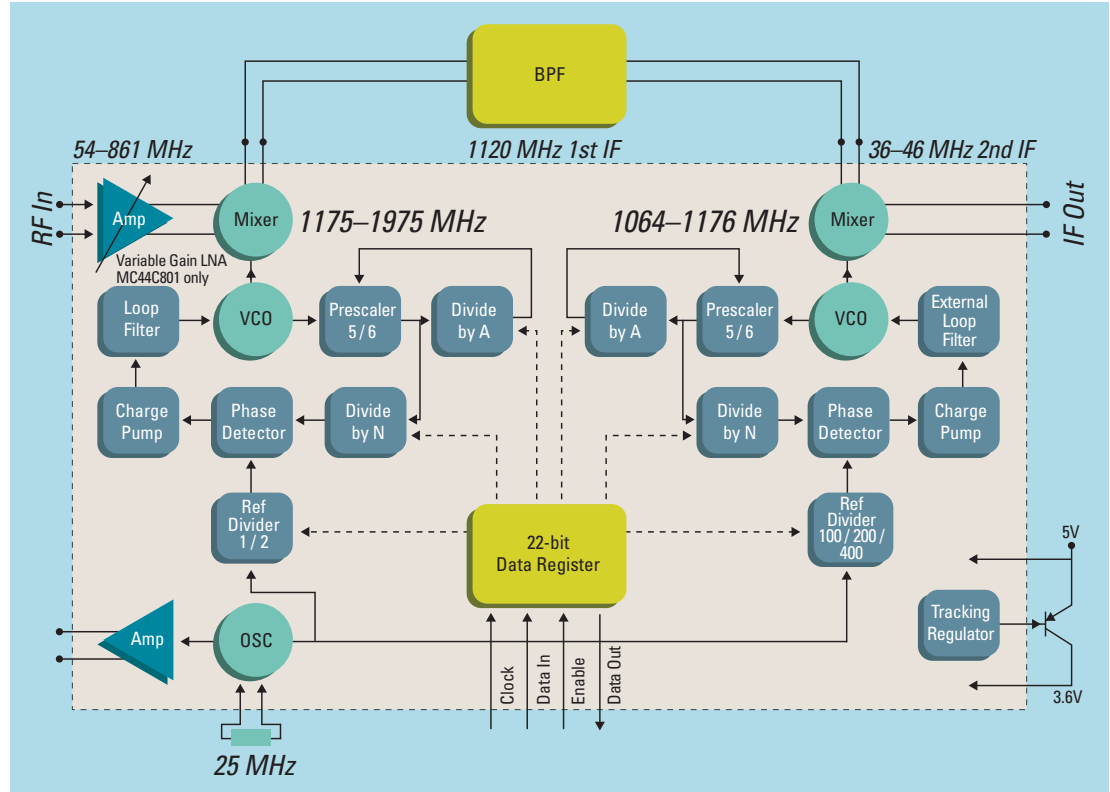

KEY FEATURES OF MC44C800/MC44C801

- Two frequency synthesizers and prescalers
- One fully integrated VCO and one VCO requiring only an external inductor
- One up conversion mixer
- One down conversion mixer
- One variable gain LNA with 21 dB gain control (MC44C801 only)
- One reference oscillator circuit (requiring external 25 MHz crystal)
- Typical CTB of -66 dBc, CSO of -66 dBc and Xmod of -57 dB with +3 dBmV AGC attack point
- Typical noise figure of MC44C801 is 5.5 dB
- Phase noise at 10 KHz offset of -94 dBc/Hz, typical
- Internal 3.6V regulator to enable single 5V supply operation
- SPI bus interface
- Internal self-diagnostic circuits
- Power down mode with fast startup
- No external image filter required

LEARN MORE

For more information on Motorola's products, visit www.motorola.com/semiconductors. For all other inquiries, please contact the Motorola Customer Response Center at (800) 521-6274 or click on Contact Us at www.motorola.com/semiconductors.

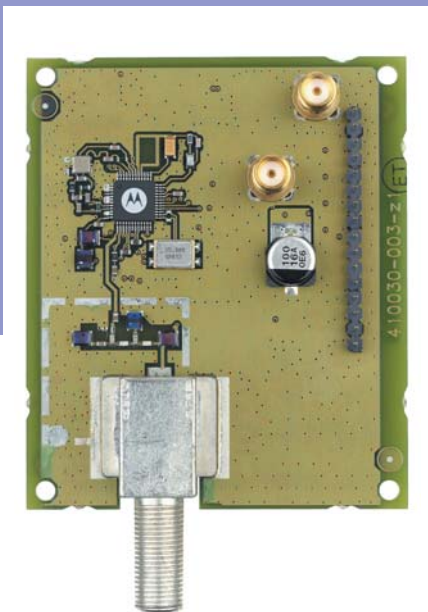

MOTOROLA and the Stylized M Logo are registered in the U.S. Patent & Trademark Office. All other product or service names are the property of their respective owners.
© Motorola, Inc. 2002.