

Power Actuation

# MC33385

## Quad Low-Side Driver

Low-Side Switch

### DESCRIPTION

The MC33385 is a Quad Low-side Driver fully protected switch. This device is a general purpose Low-side Driver but has been especially designed to operate in engine management application as injector driver or automotive gear box. It is interfaced directly with a microcontroller for parallel control of the load and the individual output diagnostic is done through a SPI. The diagnostic logic recognizes 4 failure types at each output stage: overcurrent, short to GND, open load, and over-temperature.

### 33385 SIMPLIFIED APPLICATION DIAGRAM

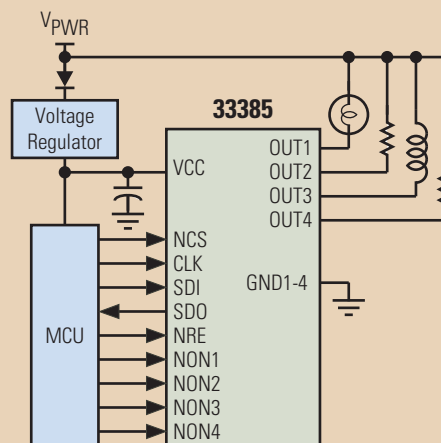

ARCHIVE INFORMATION

ARCHIVE INFORMATION

### APPLICATIONS

- Automotive Systems
- Aircraft Systems
- Robotic Systems
- Farm Equipment
- Industrial Actuator Controls
- Fractional Horsepower DC Motor Controls
- Marine Applications
- Applications where Low-Side Switch Control with Diagnostics is Necessary

### PERFORMANCE

### TYPICAL VALUES

Outputs	4
$R_{DS(ON)}$ @ 25°C	0.250 $\Omega$
Operating Voltage	9.0 - 45 V
Peak Current	3.0 A each output
Control	Parallel
Operating Temperature	-40°C $\leq T_A \leq$ 85°C
Junction Temperature	-40°C $\leq T_J \leq$ 100°C

## FEATURES

- RDSON of 250mΩ per Output at 25°C
- Supplied from the main 5V V<sub>CC</sub>
- Input CMOS Compatible
- Diagnostic through SPI
- Nominal Current of 2A per Output
- Current Limitation at 3A with Automatic Turn Off
- Output Internally Clamped at 50V typ for Inductive Load Drive
- Junction to Case Thermal Resistance of 4.4°C/W
- Individual Output over Temperature Shutdown
- Devices available for comparison are in the Analog Product Selector Guide - SG1002 and Automotive Product Selector Guide - SG187

PROTECTION	DETECT	LIMITING	SHUT DOWN	AUTO RETRY	STATUS REPORTING
Overvoltage		•			
Undervoltage	•			•	
Overcurrent/SC			•		•
Overtemperature			•		•
Open Load					•
Short to GND					•
Short to V <sub>PWR</sub>				•	

## CUSTOMER BENEFITS

- Simple solution for operating low-side power FETs at voltage up to 45 V
- Simple low-side switching of output inductive loads due to internally clamped outputs
- Simple system design with direct interfacing to a microprocessor
- Reduced PC board space resulting in enhanced application reliability and lower cost
- Increased efficiency when paralleling outputs

## QUESTIONS

- Do you need to reduce system costs of low-side switching four loads using a microcontroller?
- Do you have to design four high-efficiency switches to control incandescent or inductive loads (or combinations of both) over a wide temperature range?
- Are you looking for an easy-to-design low-side switch, capable of switching four different high-voltage loads (45 VDC)?
- Do you require four “smart” independent low-side switches with internal protection features as well as fault reporting via a SPI interface?

## ORDERING INFORMATION

Device	Temperature Range (T <sub>A</sub> )	Package
**33385DH/R2	-40°C to 125°C	20 HSOP
**33385VW/R2		

Data Sheet Order Number MC33385

\*\*Prefix Index:  
PC = Engineering Samples; MC = Production

Contact Sales for Evaluation Kit Availability

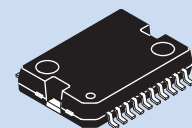

**20 HSOP**  
1.27 mm Pitch  
16.0 mm x 11.0 mm Body  
12.2 mm x 6.9 mm Exposed Pad