

# NTAG X DNA

Secure NFC T4T compliant IC for PKI (Public Key Infrastructure)

Rev. 3.2 — 6 July 2026

Product data sheet

## 1 General description

---

NTAG X DNA is a secure authentication IC for IoT platforms, electronic accessories, and consumable devices such as home electronic devices, mobile accessories, and medical supplies.

NTAG X DNA contains ECC key pairs, which can be generated by the IC itself to make sure that private keys are never exposed outside the IC. Also it performs cryptographic operations for security critical communication and control functions.

NTAG X DNA offers Common Criteria EAL 6+ security certification with AVA\_VAN.5 on product level [\[1\]](#) and supports a generic Crypto API providing AES, ECDSA, ECDH, SHA, HMAC, and HKDF cryptographic functionality for users. Asymmetric cryptography features support 256-bit ECC over the NIST P-256 and brainpoolP256r1 curves. Symmetric cryptography features support both AES-128 and AES-256. It also supports PKI-based mutual authentication including certificate handling. The CC security certification ensures that the IC security measures and protection mechanisms have been evaluated against sophisticated noninvasive and invasive attack scenarios.

NTAG X DNA supports an I<sup>2</sup>C contact interface with two GPIOs and an ISO 14443 contactless interface.

NTAG X DNA supports a low-power design, and consumes only 5  $\mu$ A at Halt mode when an external VDD is supplied.



## 2 Features and use cases

### 2.1 Use cases

NTAG X DNA can be used for:

- Secure key(s) and certificate(s) storage
- PKI (Public Key Infrastructure) based authentication and communication
- Device only, device-to-device, and device-to-cloud authentication
- Secure connection for consumer devices, industrial machines, and medical devices
- Battery passport and/or Digital product passport
- Device to meet increasing cybersecurity requirements

### 2.2 Key features

NTAG X DNA is designed to support many IoT applications and solves the problems in IoT applications' full life cycle.

- ECC key generation on the IC, and provisioning item level certificate(s) in NXP, or in the field.
- The following cryptographic primitives are supported: AES-128/256 (ECB, CBC, CMAC, CCM, GCM), ECDSA, and ECDH over NIST P-256 and brainpoolP256r1, SHA-256/384, HMAC, and HKDF. This allows to support advanced cryptographic protocols such as SIGMA-I, TLS1.3 and Matter.
- SUN (Secure Unique NFC) message with AES encryption and ECDSA signature or AES CMAC
- Nonreversible monotonic counter as the usage counter
- Configurable silent mode, which does not interfere with the standard ISO 14443 communication
- Delivery of the list of UID and certificates at shipping from NXP
- Support 2 interfaces - ISO 14443 and I<sup>2</sup>C, and possibility to change the communication interface without rebooting
- NFC tag compliant to NFC Forum specifications, see [\[15\]](#)[\[16\]](#)
- Low Hmin enabling larger operating volumes (depending on power provided by the PCD and antenna geometry)
- Interface compliant with ISO/IEC 14443-2/3A/4 with data rates 106/212/424/848 kbit/s, and Very High Bit Rate (VHBR) 1.7 Mbit/s and 3.4 Mbit/s - PICC to PCD only
- I<sup>2</sup>C target operates at 100 kHz (standard mode), 400 kHz (fast mode), or 1 MHz (Fast-mode Plus)
- Two configurable GPIOs; 1 GPIO can be used for power downstream - up to 10 mW for batteryless applications
- 1 V operation with 1.5 V battery
- Small footprint on PCB with WLCSP16

## 2.3 Configuration

NTAG X DNA can be used as an I<sup>2</sup>C target with Host MCU.

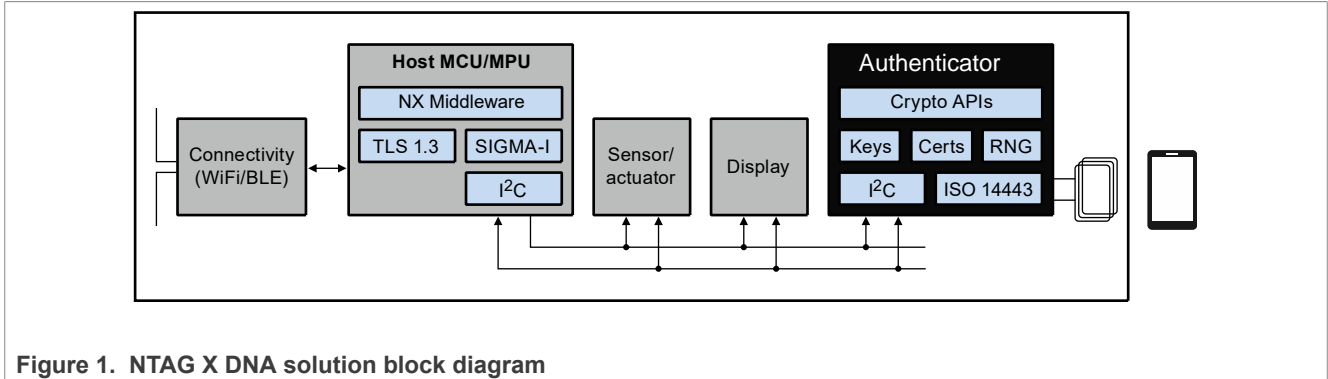

Figure 1. NTAG X DNA solution block diagram

## 2.4 Configuration as NFC tag

NTAG X DNA can be used as an NFC tag, which is compliant to the NFC Forum Type 4 Tag [15], and NDEF [16] with PKI-based digital signature.

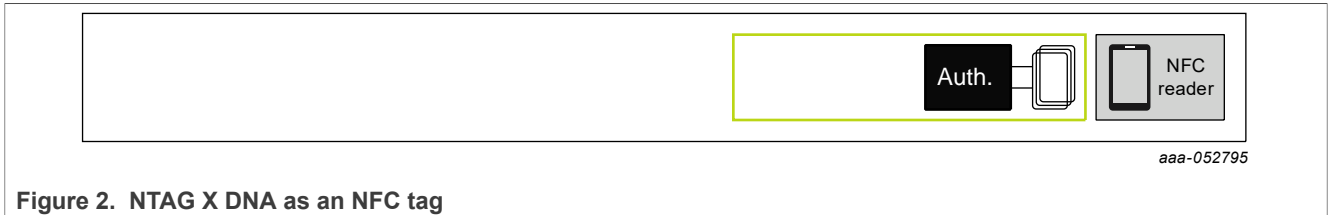

Figure 2. NTAG X DNA as an NFC tag

The target application is as an accessory for mobiles or electronic devices. It is possible to support a multiple-stack use case having multiple tags in a single field.

## 2.5 Configuration as authenticator

NTAG X DNA can be used for consumable authentication. An MCU can read the certificate from NTAG X DNA and perform ECC-based authentication via ECDH, ECDSA, or full SIGMA-I protocol (Section 6.4.2).

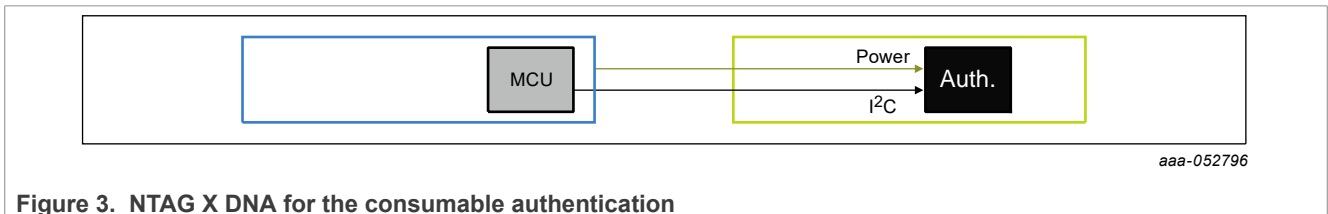

Figure 3. NTAG X DNA for the consumable authentication

The consumable part can also be authenticated by an NFC reader or a mobile by a user. The user can check the originality of the consumable part and get its status, for example, how many times the device has been powered up or used with a nonreversible monotonic counter.

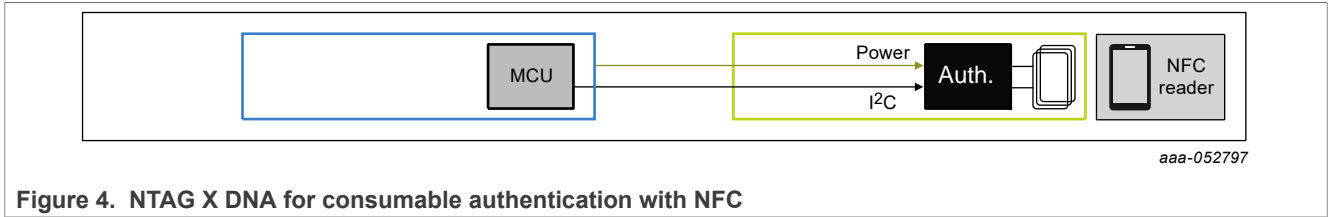

Figure 4. NTAG X DNA for consumable authentication with NFC

With this configuration, the target application is as an accessory for mobiles or electronic devices (for example, USB-C cable, Wireless charger, etc.)

## 2.6 Configuration as crypto accelerator and diagnostics

NTAG X DNA can be used for the host MCU as a crypto accelerator.

The credential for the host can be provisioned by the NFC reader, and configured at the last stage of the production (for example, production date, qualification status, etc.).

NFC can be used to diagnose the host with a tap which can be useful in case the device has only a small or no display (for example, powered or not, to check the IP address when there is any connectivity issue, etc.).

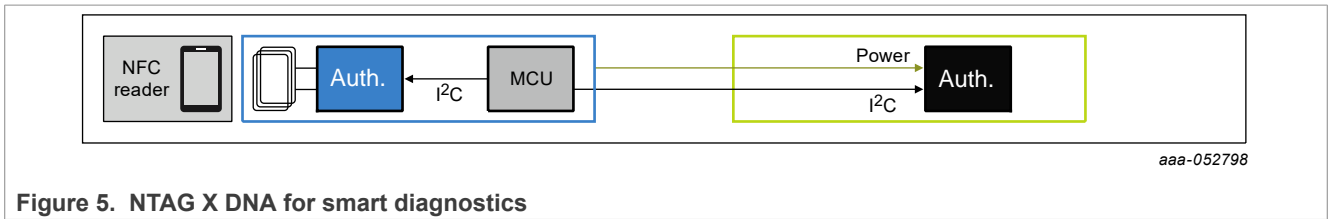

Figure 5. NTAG X DNA for smart diagnostics

2.7 Configuration for smart sensor

NTAG X DNA can be used for smart sensor applications.

The sensed or monitored data can be signed with one or more keys in NTAG X DNA to prove the originality of the data with non-repudiation. The data can be sent to the server without leaking any information using the SIGMA-I protocol and subsequent secure messaging.

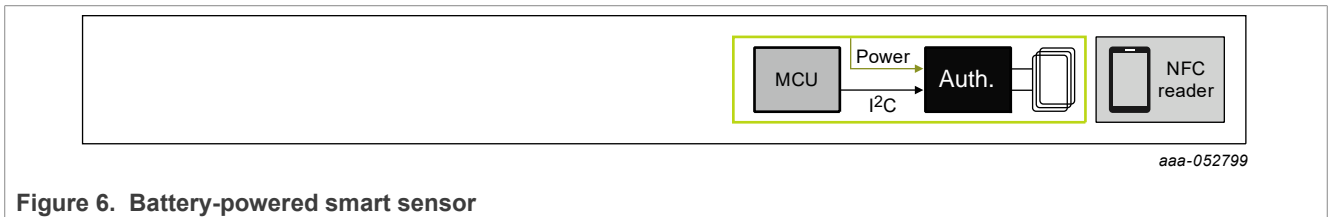

Figure 6. Battery-powered smart sensor

NTAG X DNA can deliver up to 10 mW to the MCU and sensors, which can be powered without a battery. With energy harvesting, it is possible to be used in nondestructive applications. In addition to eco-friendly applications, the energy harvesting can make batteries obsolete.

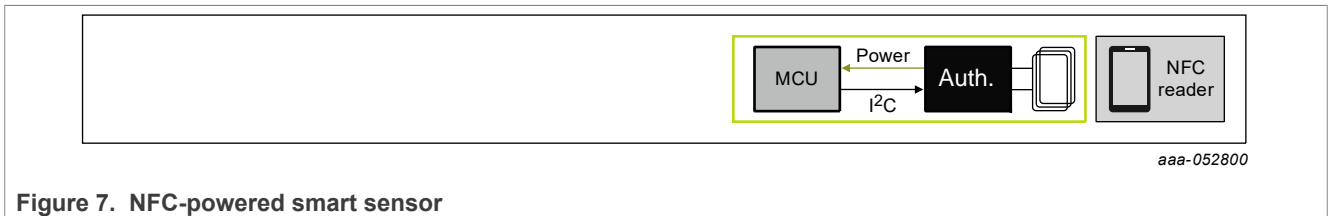

Figure 7. NFC-powered smart sensor

2.8 Configuration to secure IoT applications

NTAG X DNA can be used for many other IoT applications.

With many other wired/wireless standards - WiFi, Bluetooth, ZigBee, Thread, NTAG X DNA can be used to store keys and certificates securely, provide one-way and/or mutual authentication, and transferred sign data.

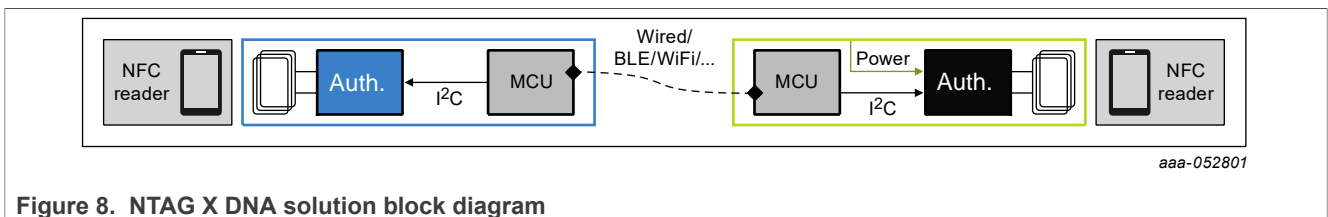

Figure 8. NTAG X DNA solution block diagram

In this configuration, the target applications are IoT platforms supporting cloud onboarding and secure communications, for example, with Matter.

### 3 Ordering information

Table 1. Ordering information

Type number	Package		
	Name	Description	Version
NT4PLDJUK	WLCSP	NTAG X DNA with 17 pF input capacitance, 16 kB memory	SOT2127-2
NT4PLDJHN2	HVQFN	NTAG X DNA with 17 pF input capacitance, 16 kB memory	SOT917-6(DD)
NT4PMDJU32	FFC	NTAG X DNA with 50 pF input capacitance, 16 kB memory	-

## 4 Block diagram

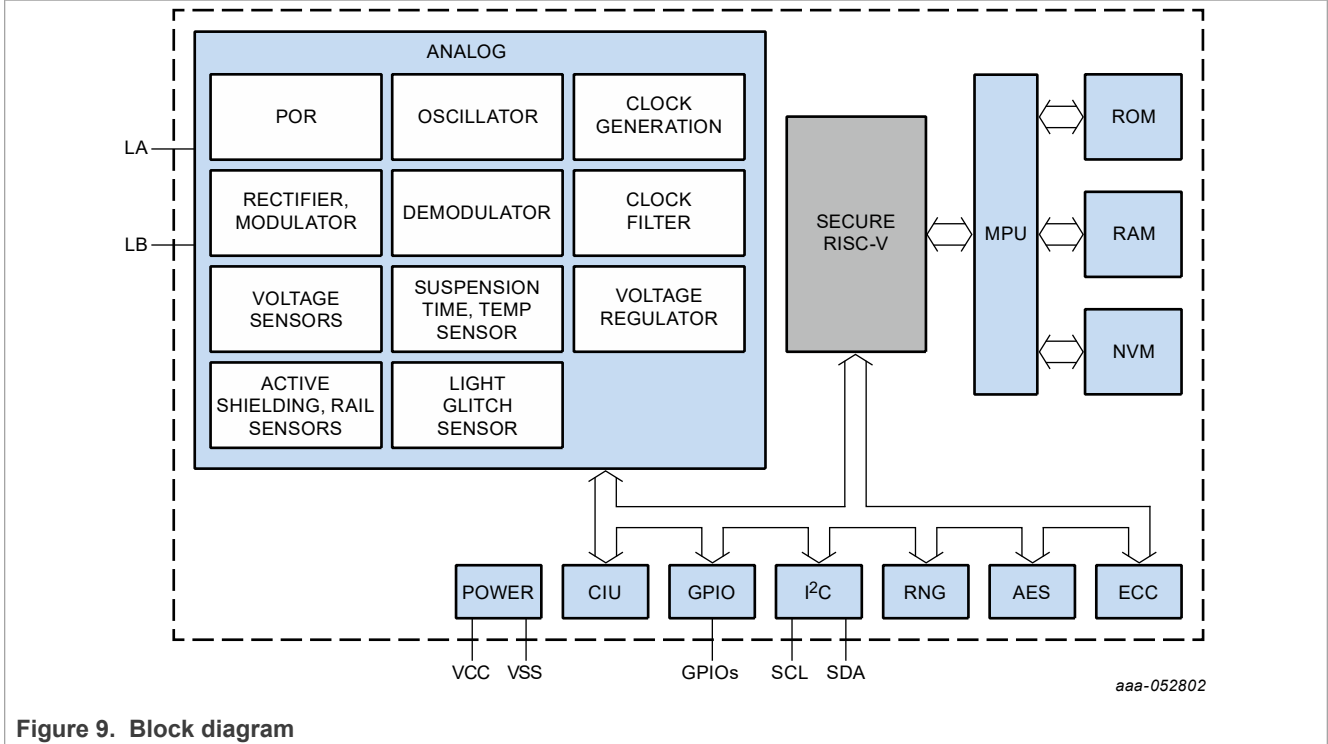

Figure 9. Block diagram

## 5 Pin description

NTAG X DNA provides eight pins:

**Table 2. NTAG X DNA pin configuration**

Symbol	Description
L <sub>A</sub>	ISO14443 Antenna Connection. If not used, connect to V <sub>SS</sub>
L <sub>B</sub>	ISO14443 Antenna Connection. If not used, connect to V <sub>SS</sub>
V <sub>CC</sub>	Logic and I <sup>2</sup> C/GPIO/ISO14443 interface power supply voltage input
V <sub>SS</sub>	Ground
GPIO1	General Purpose IO, used for power output in Power Harvesting Mode and for NTAG Tag Tamper functionality
GPIO2	General Purpose IO
SDA	I <sup>2</sup> C target data I/O
SCL	I <sup>2</sup> C target clock input

Refer to the available pin outs in [Section 11 "Package information"](#).

## 6 Functional description

NTAG X DNA supports arbitration between the NFC and I<sup>2</sup>C interface, by serving the first interface where activity is detected. Further communication interfaces transfer is supported as specified in [Section 6.14.1](#).

In the remainder of this document, NFC terminology is often used to refer to the NTAG X DNA, i.e. PICC, PD, or card. Similarly, PCD or reader is often used for the host communicating with the NTAG X DNA. With PICC level, the MF level of the ISO/IEC 7816-4 is referred to, for example for what is selected after a PoR.

### 6.1 NFC support

NTAG X DNA is fully compliant to ISO/IEC 14443-2 [\[2\]](#) radio frequency power and ISO/IEC 14443-3 [\[3\]](#) signal interface, initialization, and anticollision. NTAG X DNA uses the transmission protocol as specified in ISO/IEC 14443-4 [\[4\]](#) of PICC Type A.

#### 6.1.1 ISO/IEC 14443 parameter values

This section describes the values for ISO/IEC 14443 activation and selection. Usage of Random ID can be changed using the [SetConfiguration](#) command.

Note that any change in the ISO/IEC 14443 parameter values through [SetConfiguration](#) requires a power cycle to make those changes effective.

#### ATQA

The ATQA value is 0x0344, which denotes double size (7-byte) UID. However, NTAG X DNA offers configuration of Random ID, which is single size (4-byte). If the Random ID feature is enabled, then the ATQA is changed to 0x0304. According to ISO/IEC 14443-3, the ATQA bytes are transmitted as LSB first.

#### SAK

For double size UID, the value of SAK1 in cascade level 1 is 0x04, indicating that the UID is not complete. SAK2 in cascade level 2 is 0x20, indicating UID is complete and supporting ISO/IEC 14443-4. For single size UID, which is used in the Random ID case, the value of SAK is 0x20, indicating UID is complete and supporting ISO/IEC 14443-4.

#### UID

The ISO/IEC 14443-3 compliant UID is programmed and locked during production. The first byte of the double size UID is fixed to 0x04, indicating NXP as the manufacturer.

#### ATS

The value of the ATS of NTAG X DNA is as follows:

Table 3. ATS value

ATS Parameter	Value	Comment
TL	0x06	Length of ATS
T0	0x78	TA(1), TB(1), TC(1) present in ATS and the frame size is 256 bytes
TA(1)	0x77	Different communication speed can be set in each direction supports communication speeds 212, 424, 848 kbit/s in both directions

Table 3. ATS value...continued

ATS Parameter	Value	Comment
TB(1)	0x71	Max frame waiting time is 38.66 ms, start frame guard time is 604 μs
TC(1)	0x02	CID supported
T1	0x80	Historical byte

### 6.1.2 Setting of higher communication speed

After receiving an ATS, a PPS request can be sent to the NTAG X DNA to set up a higher communication speed up to 848 kbit/s according to ISO/IEC 14443-4, see [4]. Also NTAG X DNA can support VHBR (very high bit rate) up to 3.4 Mbps for PICC to PCD.

### 6.1.3 Half-duplex block transmission protocol

NTAG X DNA uses a half-duplex block transmission protocol as specified in ISO/IEC 14443-4. It is fully compliant to block format, frame waiting time, frame waiting time extension, protocol operation, and all rules or handling as in [4].

### 6.1.4 Silent mode

NTAG X DNA supports an alternative protocol activation sequence, similar to ISO/IEC 14443-3 protocol activation from [3]. This is called “silent mode”, as it avoids interference of the NTAG X DNA with other NFC products supporting the standard ISO/IEC 14443-3 protocol activation.

NTAG X DNA is either in silent mode, or it supports the standard ISO/IEC 14443-3 protocol activation. The latter is the default configuration at delivery. The mode can be configured with [SetConfiguration](#) (Option 0x0D), as defined in [Section 6.6.3.2](#).

When silent mode is enabled, NTAG X DNA shall instead of the standard REQA/WUPA commands, see [Section 6.6.3.2](#), support the following alternative proprietary commands:

- REQS:(1111010)b (7 bit), i.e. 0x7A, or any other customized 7-bit value different from WUPS.
- WUPS:(1111101)b (7 bit), i.e. 0x7D, or any other customized 7-bit value different from REQS.

The commands REQS, resp. WUPS, will have, when silent mode is enabled, exactly the same behavior and timing as the commands REQA, resp. WUPA, in the default operation mode, i.e. when silent mode is disabled. REQA/WUPA and REQS/WUPS are mutually exclusive, which means that when silent mode is disabled, REQS/WUPS are not supported and triggers an Error transition, as any other RFU short frame value, see [3]. Similarly, when silent mode is enabled, REQA/WUPA are not supported and triggers an Error transition.

## 6.2 I<sup>2</sup>C support

NTAG X DNA supports I<sup>2</sup>C target communication with 7-bit target address according to [17].

The following bus speeds are supported, though potentially limited by pullup resistance and load capacitance depending on the HW configuration.

- 100 kHz (Standard-mode)
- 400 kHz (Fast-mode)
- 1 MHz (Fast-mode Plus)

At the data link layer, the T=1' protocol as specified in [18] is supported. Only the default parameter values are specified here.

6.2.1 I<sup>2</sup>C parameter values

6.2.1.1 Target address

The default target address is 0x20. The target address can be changed through [SetConfiguration](#) Option 0x10, see [Section 6.6.3.2](#).

6.2.1.2 Communication interface parameters

The communication interface parameters (CIP) as defined by [18] are specified in [Table 4](#).

Table 4. I<sup>2</sup>C communication interface parameters

Name	Length	Description	Value
PVER	1	Protocol Version: [18] defines version '01' of the protocol.	0x01
Length of IIN	1	Length of Issuer Identification Number	0x04
IIN	3-4	Issuer Identification Number (according to [7812-1], BCD encoded)	0x63070093
PLD	1	Physical Layer ID: '01' for SPI / '02' for I <sup>2</sup> C	0x02
Length of PLP	1	Length of Physical Layer Parameters	0x08
Configuration	1	Characteristics supported by SE: b1= 0: Clock stretching not supported Other bits: RFU	0x00
PWT	1	Power wake-up Time (ms)	0x02
MCF	2	Maximal Clock Frequency at which the SE may operate (in kHz)	0x03E8 (1 MHz)
PST	1	Power-Saving Time-outs (in ms)	0x00
MPOT	1	Minimum Polling Time (conditional to Polling Mode support) (in ms)	0x01
RWGT	2	R/W Guard Time (in μs)	0x0064
Length of DLLP	1	Length of Data Link Layer Parameters	0x04
BWT	2	Block Waiting Time (in ms)	0x03E8 (ca. 1 sec)
IFSC	2	Maximum Information Field Size of the SE (in bytes) (i.e. initial value)	0x00FE
Length of HB	1	Length of Historical Bytes (max. 32 bytes)	0x00
Historical Bytes	Var	Empty	-

PWT value does not depend on whether the Halt watchdog Timer (HWDT) has been enabled with [SetConfiguration](#) Option 0x14, see [Section 6.6.3.2](#).

6.2.2 I<sup>2</sup>C Application Remarks

6.2.2.1 Power Management

NTAG X DNA contains an adaptive power management system reducing or stopping internal clocks.

In case of internal voltage drops occurring in weak field conditions when powered via the NFC interface or during switching of the VCC.

In case the internal clock is stopped NTAG X DNA might not be able to serve the I<sup>2</sup>C bus while the internal clock is stopped. In this case the host will read 'FF' while the internal clock is stopped.

This cases will be detected with high probability by the CRC check.

The recommended error-recovery on failed CRC checks is as following:

1. Read IFSC number of bytes to clear before continuing.
2. Send R-Block CRC Fail to Card

In case the length information bytes are read as FF the host protocol stack shall abort reading after the maximum frame size (254+6 bytes) supported by NTAG X DNA, e.g. by checking if the response is longer than IFS + protocol overhead.

### 6.2.2.2 Write after Write behavior

For Write after Write with two correct transmit messages the device response is discarded when the new message is received. Instead of the expected read message an error message A5-82-00-00-89-E0 (Other Error).

### 6.2.2.3 Waiting Time Extension behavior

The default block waiting time is defined as 300ms and shall not be changed. Changed block waiting times may lead to missing Waiting Time Extension (WTX) interrupts in case NFC and I2C communication.

## 6.3 Command format and chaining

### 6.3.1 Native command format

NTAG X DNA always communicates in ISO/IEC 7816-4 wrapped mode as described in [Section 6.3.2](#). Nevertheless, it is important to understand the basic format of native commands which consist of the following parts.

A command as sent by the PCD consists of the concatenation of:

- the command code (Cmd)
- zero, one or more header fields (CmdHeader)
- zero, one or more data fields (CmdData)

The response as sent by the PICC consists of the concatenation of:

- the return code (RC)
- zero, one or more data fields (RespData)

NTAG X DNA supports the APDU message structure according to ISO/IEC 7816-4 [\[5\]](#) for:

- wrapping of the native command format into a proprietary ISO/IEC 7816-4 APDU
- a subset of the standard ISO/IEC 7816-4 commands ([ISOSelectFile](#), [ISOReadBinary](#), [ISOUpdateBinary](#))

**Remark:** Communication via native ISO/IEC7816-4 commands without wrapping is not supported.

On the native command interface, plain command parameters consisting of multiple bytes are represented least significant byte (LSB) first. Similar as for ISO/IEC 14443 parameters during the activation, see [\[3\]](#). For cryptographical parameters and keys (including the random numbers exchanged during authentication, the TI and the computed MACs), this does not hold. For these, the representation on the interface maps one-to-one to the most significant byte (MSB) first notation used in this specification.

Within this document, the '0x' prefix indicates hexadecimal integer notation, i.e. not reflecting the byte order representation on the command interface at all.

6.3.2 ISO/IEC7816-4 communication frame

NTAG X DNA uses ISO/IEC 7816-4 [5] type APDUs for command-response pair for both, wrapping of native commands, as outlined in Section 6.3.1 and standard ISO/IEC 7816-4 commands.

For all parameters of standard ISO/IEC 7816-4 commands, the representation on the interface is most significant byte (MSB) first notation. As data like the 2-byte ISO/IEC 7816-4 file identifiers, are in different order for the wrapped native commands, this needs to be taken into account.

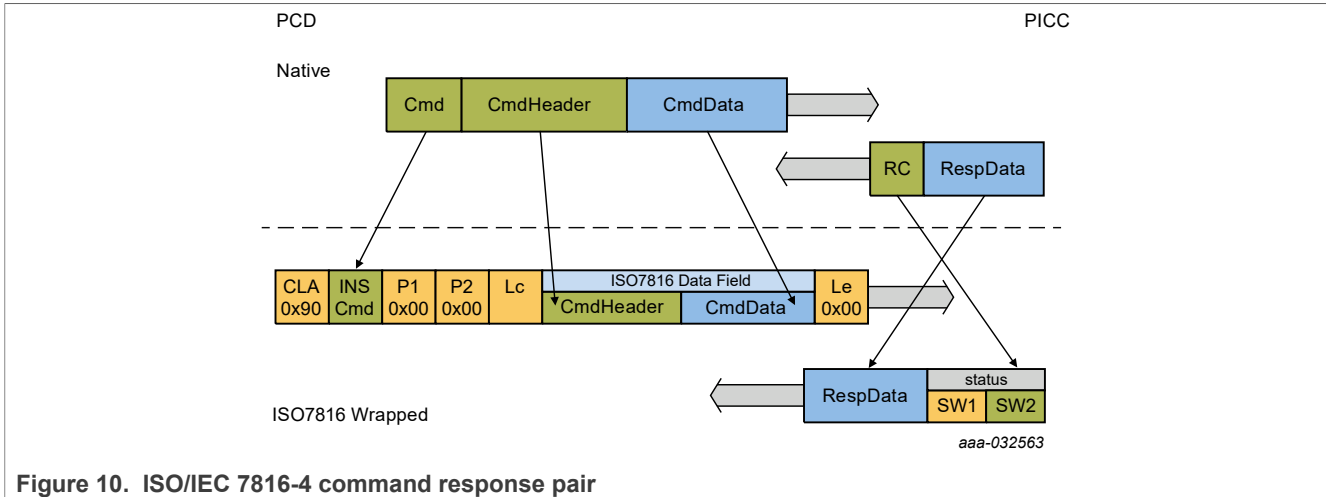

Figure 10. ISO/IEC 7816-4 command response pair

Table 5. ISO/IEC 7816-4 command fields

Field	Description	Length
Command header	Class byte (CLA)	1
	Instruction (INS)	1
	Parameters (P1,P2)	2
Lc field	Length of command data field (Lc), absent if no data field is present	1, 3
Command data field	Absent if no data is sent in the command	Lc
Le field	Expected response length. If Le is 0x00, then all available data is sent back for ISO/IEC 7816-4 standard commands. For wrapped commands, Le must always be set to 0x00.	1, 2, 3

In general, NTAG X DNA, supports Extended Length fields for Lc and Le, see [5]. However, for some commands the supported input size is restricted as specified in the command definition.

Table 6. ISO/IEC 7816-4 response fields

Field	Description	Length
Response data field	Response data if any, absent if no response data	up to Le
Response trailer	status byte (SW1SW2)	2

The field length and presence might vary for different commands, refer to the specific command description in Section 7.

6.3.3 Command chaining

NTAG X DNA supports standard ISO/IEC 14443-4 [4] command chaining in the following cases:

- the PICC supports ISO/IEC 14443-4 chaining to allow larger command or response frames than the supported buffer size for variants of the following commands:
  - Native commands wrapped into ISO/IEC 7816-4 APDU: [ReadData](#), [WriteData](#), see [Section 7](#).
  - Standard ISO/IEC 7816-4 commands: [ISOReadBinary](#), [ISOUpdateBinary](#)  
i.e. every command where a larger frame size can occur.
- the PICC automatically split a response in several frames to fit with the FSD frame size supported by the PCD and communicated in the RATS.

When a PCD applies ISO/IEC 14443-4 chaining, see [\[4\]](#), it must assure the reassembled INF field containing the command header (i.e. ISO/IEC 7816-4 header bytes and/or (Cmd || CmdHeader)) fits within the PICC's buffer (FSC) communicated in the ATS. If not, the PICC may respond with LENGTH\_ERROR.

The ISO/IEC 14443-4 chaining does not influence the secure messaging. This means that the secure messaging mechanisms are applied as if the command or response would have been sent in a single large frame. With regard to command execution, commands are handled as if they were received in one large frame, except for write commands where the total frame size can be larger than the supported FSC ([WriteData](#) and [ISOUpdateBinary](#)). In this case, command execution is started before the complete command is received.

For single frame write operations or chained frames that fit within the supported FSC it is ensured that either the data is completely written or not at all.

## 6.4 Authentication and Secure Messaging

### 6.4.1 Authentication overview

The NTAG X DNA supports several mutual authentication protocols:

- symmetric mutual authentication: this authentication is initiated by [AuthenticateEV2First](#) or [AuthenticateEV2NonFirst](#). The protocol is inherited and compatible with NTAG42x and MIFARE DESFire. It is based on AES-128 or AES-256.
- asymmetric mutual authentication: this authentication is initiated by [ISOGeneralAuthenticate](#). It is based on 256-bit ECC.

Both mutual authentication methods initiate an EV2 secure messaging channel, see [Section 6.4.6](#) based on AES-128 or AES-256 session keys.

Each authentication option can be used with different keys and on different I/O interfaces. However, the NTAG X DNA only supports a single authentication session. The authentication session applies to the I/O interface, which opened it. The other I/O interface has no current authentication session. The current session shall be closed if any of the following occur:

- a new mutual authentication is initiated (on either interface)
- the NTAG application is selected (on either interface)
- the key used to open the session is changed (for symmetric mutual authentication)
- the device enters HALT state
- the device is reset
- the OS processes an erroneous command on the interface, which opened the authentication session

The fundamental states as listed below are introduced in [Figure 11](#).

- **VCState.NotAuthenticated**: This is the default state where there is no active authentication. The AuthKey is invalidated in this state. This state is reached after POR and activation.
- **VCState.PartiallyAuthenticated**: In this state, an authentication is ongoing. The NTAG X DNA is expecting the second part. This means that any previous active authentication has already been lost.
- **VCState.AuthenticatedAES**: there is an active authentication reached by successfully executing the symmetric authentication protocol initiated with [AuthenticateEV2First](#) or [AuthenticateEV2NonFirst](#). EV2 Secure Messaging, as defined in [Section 6.4.6](#), is active. The targeted key of the last authentication is remembered as an AuthKey. Depending on these key access rights to subsequent commands may be granted or not.
- **VCState.AuthenticatedECC**: there is an active authentication reached by successfully executing the asymmetric mutual authentication protocol initiated with the [ISOGeneralAuthenticate](#) (CLA 0x00, INS 0x86, targeting a Sigma-I protocol). Also here, symmetric AES-based EV2 Secure Messaging, as defined in [Section 6.4.6](#), is active. Access rights in this state depend on the targeted [CARootKey](#) and/or reader certificates presented during the authentication, see [Section 6.5.2](#) and [Section 6.5.3](#).

The transitions to and from those states are related to the secure messaging specification.

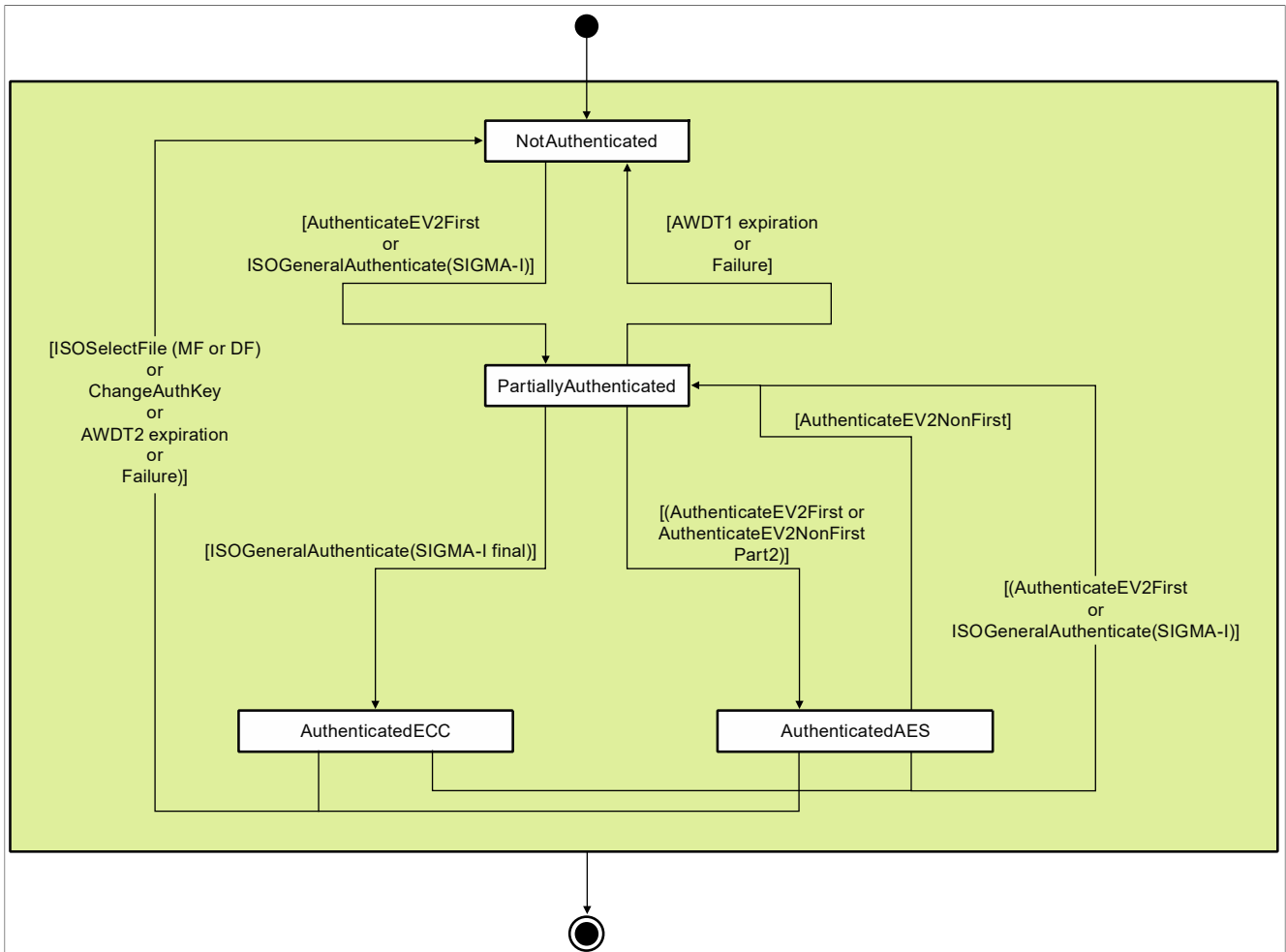

aaa-052803

Figure 11. Authentication State Diagram

Notes for Figure 11:

- Failure indicates any error: the NTAG X DNA switches to the VCState.NotAuthenticated. In these cases the response is already sent with CommMode.Plain (as always in VCState.NotAuthenticated).
- If enabled, AWDT2 expiration aborts an ongoing authentication attempt, moving the NTAG X DNA back from VCState.PartiallyAuthenticated to VCState.NotAuthenticated.
- If enabled, AWDT1 expiration aborts an active authentication session, moving the NTAG X DNA back from VCState.AuthenticatedAES or VCState.AuthenticatedECC to VCState.NotAuthenticated.
- The authentication process consists of two parts. If only the first part is received, then any command different from the expected second part results in a failure.ISO/IEC 14443-4 deselect is allowed at any time.
- In both, VCState.AuthenticatedAES and VCState.AuthenticatedECC, the same AES-based secure messaging applies.
- ChangeAuthKey indicates ChangeKey targeting the currently authenticated key.

**6.4.2 SIGMA-I authentication with [ISOGeneralAuthenticate](#)**

The NTAG X DNA supports an asymmetric based authentication protocol. Asymmetric protocol exchanges are made via the [ISOGeneralAuthenticate](#) command outlined in [Section 7.3.1](#). Sending the [ISOGeneralAuthenticate](#) command to initiate a SIGMA-I mutual authentication resets any ongoing mutual authentication exchange or already established secure channel session. The NTAG application must be selected before asymmetric protocol execution can commence with [ISOSelectFile](#), see [Section 6.17.1.4](#).

The Sigma-I protocol consists of an exchange of three messages between the *Initiator (or SIGMA-I Verifier)* and the *Responder (or SIGMA-I Prover)*. In addition, if the certificates required are not found in the certificate cache (or if caching is not supported) then certificate request and reply messages are exchanged.

The SIGMA-I protocol can be executed with the host as the initiator (or SIGMA-I Verifier) or the NTAG X DNA as the initiator (with host as SIGMA-I Prover). The data format shall remain consistent no matter which role the NTAG X DNA plays.

If SIGMA-I Prover is used as the session protocol, then the host acts as the protocol responder. However, in this case, the host still needs to send the first command, initiating the message exchange.

The access rights granted to the host are by default the rights associated with the CA root public key used to validate the host's certificate chain. However, these rights can be limited further by the certificate issuer via a proprietary x.509 certificate extension. A certificate shall never have more access rights than its parent certificate.

**6.4.2.1 Session keys**

As part of the protocol, both sides generate shared session keys and IV (nonce value) as follows (see [Section 6.4.2.5](#) for session key generation details):

**Table 7. SIGMA-I Session Keys**

Item	Description
K_e1	Encryption/Decryption key for message exchange
K_m1	MAC key used to generate input for session signature
IV_e1	AES CCM NONCE incremented for each message

**6.4.2.2 Message types**

Each SIGMA -I message has a TLV structure, where the tag (T of TLV) indicates the type of message, and the value (V of TLV) component is the payload. The message payload may be in plaintext, encrypted using AES-CCM, or a mixture of both, depending on the TLV tag.

The following table lists the message types, corresponding tags, and session keys to be used for encryption/decryption.

**Table 8. SIGMA-I Message Types**

Message	TLV Tag	Payload	Description
MSGI_PUBLIC_KEY	A0	Initiator sends its supported AES key sizes and its ephemeral public key	Protocol Options byte and Ephemeral ECDH public key (xP) in plaintext
MSGI_HASH_AND_SIG	A1	Initiator sends certificate hash (or full certificate) and signature	Cert hash (or full certificate) and signature encrypted with <K_e1, IV_e1>
MSGI_CERT_REQUEST	A2	Initiator requests a certificate from responder	Cert request message encrypted with <K_e1, IV_e1>

Table 8. SIGMA-I Message Types...continued

Message	TLV Tag	Payload	Description
MSGI_CERT_REPLY	A3	Initiator sends its certificate to responder	Certificate (optionally compressed), encrypted with <K_e1, IV_e1>
MSGI_ABORT_SESSION	AF	Initiator aborts protocol	None
MSGR_START_PROTOCOL	B0	Host as responder hands control to device/initiator, to start protocol	None
MSGR_HASH_AND_SIG	B1	Responder sends the session AES key size and its ephemeral public key, certificate hash and signature	Session symmetric key size and Public key (yP) in plaintext, cert hash <sup>[1]</sup> and signature encrypted with <K_e1, IV_e1>
MSGR_CERT_REQUEST	B2	Responder requests a certificate from initiator	Certificate request message encrypted with <K_e1, IV_e1>
MSGR_CERT_REPLY	B3	Responder sends its certificate to initiator	Certificate (optionally compressed) encrypted with <K_e1, IV_e1>
MSGR_ABORT_SESSION	BF	Responder aborts protocol	None
MSG_SESSION_OK	B4	Device is responder, returns control to host upon successful authentication. Secure tunnel rules now apply.	None

[1] cert hash is a hash over the complete certificate including the Signature field.

An abort message shall be sent by the card in the following scenarios:

- Abort message is received from the host.
- Host certificate chain is syntactically correct but CA root public key can't be located to verify it.
- Session key size can't be mutually agreed.

The payload of each message used during protocol exchange may be wrapped with tags that identify the contents, as shown in the following table:

Table 9. Asymmetric authentication Protocols Payload Encodings

Tag	Length	Description
0x80	0x00	Certificate request (leaf, level = 0)
0x81	0x00	Certificate request (parent, level = 1)
0x82	0x00	Certificate request (parent, level = 2)
0x83	0x01	AES key size options
0x84	0x20	Certificate Hash
0x85	0x40	ECC Signature
0x86	0x41	Ephemeral ECDH public key, plaintext, uncompressed format
0x87	<var>	Encrypted payload
0x7F21	<var>	Uncompressed certificate

### 6.4.2.3 Protocol exchange – Host as initiator

When the host is the initiator (SIGMA-I Verifier) and the device is the responder, the messages fall evenly into APDU command and response:

Table 10. NTAG X DNA as SIGMA-I responder

Message	Contents
Public key → (C-APDU) data field	A0 46 83 01 <key sizes supported> (see <a href="#">Table 12</a> ). 86 41 04 <xP, public key, 64 bytes>
Cert hash and signature ← (R-APDU) data field	B1 81 B0 83 01 <key size selected> (see <a href="#">Table 12</a> ). 86 41 04 <yP, public key, 64 bytes> 87 68 <C_k_r (see <a href="#">Section 6.4.2.6</a> ): encrypted hash and signature>
Initiator Cert request (optional) → (C-APDU)	A2 0C 87 0A // leaf cert request: 80 00 or // p1 cert request: 81 00 or // p2 cert request: 82 00 <encrypted cert request> AES_CCM_Dec(K=K_e1, N=++IV_e1, A=NULL, C=Encrypted Cert Request)
Responder Cert reply (optional) ← (R-APDU)	B3 82 xx xx // uncompressed cert: 7F 21 <cert> <encrypted certificate> AES_CCM_Enc(K=K_e1, N=++IV_e1, A=NULL, P=Certificate Info)
Cert hash and signature → (C-APDU)	A1 68 <C_k_i: encrypted hash and signature> AES_CCM_Dec(K=K_e1, N=++IV_e1, A=NULL, C=C_k_i)
Responder Cert request (optional) ← (R-APDU)	B2 0C 87 0A // leaf cert request: 80 00 or // p1 cert request: 81 00 or // p2 cert request: 82 00 <encrypted cert request> AES_CCM_Enc(K=K_e1, N=++IV_e1, A=NULL, P=Certificate Request)
Initiator Cert reply (optional) → (C-APDU)	A3 82 xx xx // uncompressed cert: 7F 21 <cert> <encrypted certificate>

Table 10. NTAG X DNA as SIGMA-I responder...continued

Message	Contents
	AES_CCM_Dec(K=K_e1, N=++IV_e1, A=NULL, C=Encrypted Certificate)
End Session ← (R-APDU)	<pre> B4 00 // mutual authentication is complete // session keys k_e2, k_m2 can be used // to send messages in secure tunnel                     </pre>

6.4.2.4 Protocol exchange – Host as responder

When the host is the responder (SIGMA-I Prover), it first transfers control to the device (initiator) by sending a control transfer message in C-APDU. The message contents are identical to the previous section, but the placement in C-APDU vs. R-APDU is reversed.

Table 11. NTAG X DNA as SIGMA-I initiator

Message	Contents
Transfer control ← (C-APDU) data field	B0 00
Public key → (R-APDU) data field	<pre> A0 46  83 01 &lt;key sizes supported&gt; (see Table 12)  86 41 04 &lt;xP, public key, 64 bytes&gt;                     </pre>
Cert hash and signature ← (C-APDU)	<pre> B1 81 B0  83 01 &lt;key size selected&gt; (see Table 12)  86 41 04 &lt;yP, public key, 64 bytes&gt;  87 68 &lt;C_k_r: encrypted hash and signature&gt; AES_CCM_Dec(K=K_e1, N=IV_e1, A=NULL, C=C_k_r)                     </pre>
Initiator Cert request (optional) → (R-APDU)	<pre> A2 0C 87 0A // leaf cert request: 80 00 or // p1 cert request: 81 00 or // p2 cert request: 82 00 &lt;encrypted cert request&gt; AES_CCM_Enc(K=K_e1, N=++IV_e1, A=NULL, P=Cert Request)                     </pre>
Responder Cert reply (optional) ← (C-APDU)	<pre> B3 82 xx xx // uncompressed cert: 7F 21 &lt;cert&gt; &lt;encrypted certificate&gt; AES_CCM_Dec(K=K_e1, N=++IV_e1, A=NULL, C=Encrypted Certificate)                     </pre>
Cert hash and signature	A1 68

Table 11. NTAG X DNA as SIGMA-I initiator...continued

Message	Contents
→ (R-APDU)	< C_k_i (see <a href="#">Section 6.4.2.6</a> ) encrypted cert hash and signature>
Responder Cert request (optional) ← (C-APDU)	<pre> B2 0C 87 0A // leaf cert request: 80 00 or // p1 cert request: 81 00 or // p2 cert request: 82 00 &lt;encrypted cert request&gt; AES_CCM_Dec(K=K_e1, N=++IV_e1, A=NULL, C=Encrypted Certificate Request)                     </pre>
Initiator Cert reply (optional) → (R-APDU)	<pre> A3 82 xx xx // uncompressed cert: 7F 21 &lt;cert&gt; // compressed cert: 7F 22 &lt;comp-cert&gt; &lt;encrypted certificate&gt; AES_CCM_Enc_(K=K_e1, N=++IV_e1, A=NULL, P=Certificate Info)                     </pre>
	<pre> // <b>mutual authentication is complete</b> // this is known implicitly by both sides // session keys k_e2, k_m2 can be used // to send messages in secure tunnel                     </pre>

### 6.4.2.5 SIGMA-I session key generation

Session key generation requires the NTAG X DNA’s ephemeral private key and the host’s ephemeral public key. The ECC domain curve to use for session key generation shall match the domain curve used to sign the NTAG X DNA’s session signature. This is defined by the targeted certificate repository.

The session key generation process is as follows:

- Validate the host’s public key
- Compute shared secret using ECDH with the private key of the NTAG X DNA and the public key of the Host.
- Select AES session key size (AES-128 or AES-256). This shall be the largest key size mutually supported by both initiator and responder. If no mutually supported key size then the mutual authentication session is aborted with a protocol error. Key size definitions are outlined in [Table 12](#).
- Generate session keys and IV used for mutual authentication
- Generate session keys used for the secure tunnel

Table 12. SIGMA-I Session Key Sizes

b7	b6	b5	b4	b3	b2	b1	b0	Description
-	-	-	-	-	-	-	x	AES-128
-	-	-	-	-	-	x	-	AES-256
x	x	x	x	x	x	--		RFU

The KDF algorithm is NIST SP800-108 compliant [10] and uses Counter Mode with AES as the PRF. The key size to use for the PRF shall match the session key size selected. As a PRF AES CMAC is used. SP 800-108 states counter-based KDF as follows:

$$K(i) := PRF(K_i, [i]2 \parallel Label \parallel 0x00 \parallel Context \parallel [L]2)$$

**K<sub>i</sub>**: the base key shall be used for generation of all session keys and IVs. This key shall be derived using SHA-256(trans\_xy) where trans\_xy = x-coordinate of shared secret | initiator's public key | responder's public key. When AES-256 is selected, then the complete 32 bytes shall be used; for AES-128 the derived bytes shall be truncated to the first 16 bytes.

**i**: two-byte iteration counter starting at 1. When AES128 is selected only 0x0001 is used; for AES 256 0x0001 and 0x0002 counter values are used and the output is concatenated.

**Label**: each mutual authentication key to be generated shall have a unique label:

- “K\_e1”, see [Section 6.4.2.1](#)
- “K\_m1”, see [Section 6.4.2.1](#)
- “IV\_e1”, see [Section 6.4.2.1](#)
- “K\_e2” for EV2 ENC, see [Section 6.4.6](#)
- “K\_m2” for EV2 MAC, see [Section 6.4.6](#)

**Context**: “SIGMA-I” for mutual authentication keys, “IVs” for mutual authentication IV or “EV2” for EV2 tunnel session keys

**L**: an integer specifying the output data length:

- 0x0100 AES-256 key
- 0x0080 for an AES-128 key
- 0x0068 for an IV\_e1.

**Note**: The CCM nonce *N* is composed of the 13 leftmost IV\_e1 bytes.

#### 6.4.2.6 NTAG X DNA Signature generation

The NTAG X DNA generates a unique signature every session, which is sent in an encrypted payload and also includes the leaf certificate hash of the NTAG X DNA. Signature generation and subsequent encryption depend on the role assumed by the NTAG X DNA. The private key and associated repository to use are either explicitly stated or the certificate repository with the lowest Id, which supports SIGMA-I shall be used.

The signature generation and encryption methodology are as follows. ECDSA-Sign and ECDSA-Verify is ECDSA Digital Signature Generation and Verification as defined in [26]. The hash function to be applied is SHA-256, as specified in NIST FIPS 180-4 [19]. AES-CMAC is according to [8] and AES\_CCM is according to [28]. The AES CCM parameters according to the formatting Appendix A from [28] are a 2-byte length field *q*, a 13-byte nonce *n*, and an 8-byte tag *t*.

The following parameters are used:

- sk\_init and sk\_resp are the targeted private keys.
- keySize\_init and keySize\_resp are the initiator key sizes supported byte and responder key size selected byte, according to [Table 12](#)
- xP and yP are respectively the host/initiator's ephemeral public key and NTAG X DNA/responder's ephemeral public key
- leaf\_cert\_hash is SHA-256 of the end-leaf certificate of the NTAG X DNA including the signature.
- A (Associated Data from [28]) is optional additional authenticated data (which is not encrypted) and is not applicable for this SIGMA-I implementation.

#### 6.4.2.6.1 NTAG X DNA as Initiator

- $Init\_ECC\_Sig = ECDSA-Sign(sk\_init, 0x02 || keySize\_init || keySize\_resp || yP || xP || AES\_CMAC(K\_m1, 0x02 || leaf\_cert\_hash))$
- $Data = leaf\_cert\_hash || Init\_ECC\_Sig$
- $C\_k\_i = AES\_CCM\_Enc(K=K\_e1, N=IV\_e1, A=NULL, P=Data)$

#### 6.4.2.6.2 NTAG X DNA as Responder

- $Resp\_ECC\_Sig = ECDSA-Sign(sk\_resp, 0x01 || keySize\_init || keySize\_resp || xP || yP || AES-CMAC(K\_m1, 0x01 || leaf\_cert\_hash))$
- $Data = leaf\_cert\_hash || Resp\_ECC\_Sig$
- $C\_k\_r = AES\_CCM\_Enc(K=K\_e1, N=iv\_e1, A=NULL, P=Data)$

#### 6.4.2.7 SIGMA-I: Verification of the host

The NTAG X DNA receives the end-leaf certificate hash and a session ECC signature from the Host. To authenticate the Host, the NTAG X DNA shall verify the session signature using a trusted public key. The trusted public key can either be a prevalidated key stored in the NTAG X DNA's certificate cache or a key authenticated through validation of the associated public key certificate. If certificate caching is disabled or the public key isn't present in the NTAG X DNA's cache then the NTAG X DNA shall request the host to provide public key certificates until the certificate chain of the leaf public key can be verified. The maximum depth of a certificate chain is 4, therefore, the NTAG X DNA shall request up to a maximum of three certificates from the host (leaf, P1 and P2). If the leaf certificate public key of the Host cannot be validated then the authentication session is terminated.

Once the public key of the Host is validated, the NTAG X DNA verifies the signature from the Host as follows. ECDSA-Verify is ECDSA Digital Signature Generation as defined in [26]. The hash function to be applied is SHA-256, as specified in NIST FIPS 180-4 [19]. AES-CMAC is according to [8].

The following parameters are used:

- $pk\_init$  and  $pk\_resp$  are the targeted public keys, retrieved from the certificate chain.
- $sig\_init$  and  $sig\_resp$  are the received signatures
- $keySize\_init$  and  $keySize\_resp$  are the initiator key sizes supported byte and responder key size selected byte, according to Table 12
- $xP$  and  $yP$  are respectively the NTAG X DNA/initiator's ephemeral public key and host/responder's ephemeral public key
- $leaf\_cert\_hash$  is SHA-256 of the host's end-leaf certificate including the signature.

When the host's session signature is validated, the host is granted the access rights (from '0' to 'D') associated with the CA root public key used to validate the host's certificate chain (or restricted subset as specified in x.509 certificate extension).

#### 6.4.2.7.1 NTAG X DNA as initiator

- $ECDSA-Verify(pk\_resp, sig\_resp, 0x01 || keySize\_init || keySize\_resp || xP || yP || AES-CMAC(K\_m1, 0x01 || leaf\_cert\_hash))$

#### 6.4.2.7.2 NTAG X DNA as responder

- $ECC\_Verify(pk\_init, sig\_init, 0x02 || keySize\_init || keySize\_resp || yP || xP ( || AES-CMAC(K\_m1, 0x02 || leaf\_cert\_hash)))$

### 6.4.3 ECC-based card-unilateral authentication

NTAG X DNA supports an ECC-based card-unilateral authentication protocol as described in this section. This allows for authenticating the card without requiring an authentication from the reader side. This protocol can be applied for Originality Check purposes, i.e. to ensure the genuineness of NTAG X DNA ICs, as described in [Section 6.18.1](#). This protocol does not open a secure messaging session.

The protocol can be executed with [ISOInternalAuthenticate](#).

As the protocol creates a trace that cannot be repudiated, the privacy implications of enabling the feature should be evaluated.

#### 6.4.3.1 Data structures and notations

##### 6.4.3.1.1 ECCKey pair

The card-unilateral authentication applies a static key pair (*Priv.B*, *Pub.B*) from which the private key *Priv.B* is stored on the card and used by the card during the protocol.

##### 6.4.3.1.2 Certificate

For the protocol, the public key *Pub.B* to be used by the reader for validating the authenticity of the card, should be authenticated through a certificate or certificate chain. This certificate (chain) can be stored on the card in a [FileType.StandardData](#) file and retrieved via the related commands before executing the [ISOInternalAuthenticate](#).

For Originality Check purposes, the certificate is trust-provisioned during manufacturing, as described in [Section 6.18.1](#).

During the further description of the protocol, the certificate validation is kept out of scope.

#### 6.4.3.2 Cryptographic primitives

##### 6.4.3.2.1 Elliptic Curve Digital Signature Generation and Verification

The card-unilateral authentication is based on the ECDSA Digital Signature Generation and Verification as defined in [\[13\]](#). The hash function to be applied is SHA-256, as specified in NIST FIPS 180-4[\[19\]](#).

The following notations are used:

$$Sig.B = ECDSA_{Sign}(Priv.B, SHA256(M))$$

$$[true, false] = ECDSA_{Verify}(Pub.B, SHA256(M), Sig.B)$$

In the above example, *B* signs the message *M* with his private key *Priv.B*, resulting in the signature *Sig.B*. *Sig.B* consists of two integers (*Sig.B.r*, *Sig.B.s*) of a size equalling the curve size, i.e. both 32 bytes for an ECC-256 curve, resulting in a 64-byte signature. With  $ECDSA_{Verify}$ , the *Sig.B* is verified to be correct for the message *M* with the public key *Pub.B*, resulting in *true* or *false*.

##### 6.4.3.3 ISOInternalAuthenticate

The authentication is initiated by [ISOInternalAuthenticate](#). A detailed command definition can be found in [Table 50](#).

The protocol can only be executed in `VCState.NotAuthenticated` and does not change the authentication state. All parameters in the command and response data field are BER-TLV data objects (DOs) encoded according to

ISO/IEC7816-4 [4] with DER length encoding. Authentication DOs are collected under the 0x7C tag according to ISO/IEC 7816-4. Other parameters use a context-specific tag according to ISO/IEC 8825-1 [20]. All DOs must be sent in the order specified in the command tables.

Upon reception of [ISOInternalAuthenticate](#), the PICC checks the [ECCPrivateKey](#) addressed by P2 if the key does not exist or is not enabled for ECC-based unilateral authentication, the command is rejected. If the targeted [ECCPrivateKey](#) has an enabled `KeyUsageCtrLimit` that was already reached, see [Section 6.8.1.2](#), the command is also rejected.

NTAG X DNA supports [ISOInternalAuthenticate](#) at the PICC level by default for originality checking with the [Section 6.18.1.1](#) at `KeyNo 0x01`. The command can be disabled for privacy purposes through [SetConfiguration Option 0x0E](#). At the application level, it depends on the key policy configured during key creation or update, whether the protocol is supported for a specific key.

Certificates related to the unilateral authentication can either be stored in a certificate repository or in [FileType.StandardData](#) files.

The parameter `OptSA` is optional. As it may be used for potential future extensions, the current implementation accepts and ignores it, including TLV-structures with a bigger length. If present, `OptSA` is included in the signature calculation to allow protection against future protocol downgrade attacks. Future implementations may then also return an `OptSB` with Tag 0x80.

Upon reception of the command, the PICC generates an own 16-byte random number `RndB` and creates the signature as follows:

```
Sig.B = ECDSAsign(Priv.B, SHA256(0xF0F0 || OptSA || RndB || RndA))
```

For `OptSA` the full TLV-structure is included, while for `RndA` and `RndB` only the 16-byte random values are included.

**6.4.3.4 Authentication overview**

The ECC-based card-unilateral authentication supported by NTAG X DNA is based on the two-pass unilateral authentication as standardized in ISO/IEC 9798-3 [21] with the following modifications:

- Identities are not communicated or included in the protocol:
  - the identity of the card may be extracted from the corresponding certificate.
  - there is no requirement for knowledge and confirmation of the reader identity by the card. Note that reader's random sufficiently ensures uniqueness and timeliness, and therefore prevents the returned token to be accepted by other parties.
- The references *A* and *B* are exchanged to be more aligned with other protocols in this document.

An overview of this asymmetric card-unilateral authentication is given in [Table 13](#).

The inclusion of a random number generated by the card prevents the reader from having full control on the data that gets “signed” by the card. This is different from a generic ECDSA signature generation as supported with [CryptoRequest](#).

**Table 13. ECC-basedcard-unilateral authentication**

PCD	PICC
<b>Knows:Pub.B</b> The PCD generates a random challenge <i>RndA</i>	<b>Knows:Priv.B</b>
<i>OptSA</i>    <i>RndA</i> →	
	The PICC generates a random <i>RndB</i> : The PICC computes its signature:

Table 13. ECC-basedcard-unilateral authentication...continued

PCD	PICC
	$Sig.B = ECDSA_{Sign}(Priv.B, SHA256(0xF0F0[  OptsA]  RndB  RndA))$
$RndB    Sig.B$ ←	
The PCD validates the signature: $ECDSA_{Verify}(Pub.B, SHA256(0xF0F0[  OptsA]  RndB  RndA, Sig.B))$	

### 6.4.4 AES-based Symmetric Authentication

#### 6.4.4.1 Command [AuthenticateEV2First](#)

In the remainder, there is made mention of First Authentication and Non-First Authentication. A First Authentication is done in state `VCState.NotAuthenticated` or in one of the authenticated states, see [Section 6.4.1](#). The Non-First Authentication can only be applied after a First Authentication, i.e. in an authenticated state. Correct application of First Authentication and Non-First Authentication allows cryptographically binding all messages within a transaction by using a transaction identifier, see [Section 6.4.6.1](#), and a command counter, see [Section 6.4.6.2](#), even if multiple authentications are required.

The following table specifies when to authenticate using First Authentication and when to use Non-First Authentication.

Table 14. When to use which authentication command

Purpose	First Authentication	Non-First Authentication
First symmetric authentication (i.e. when not in <code>VCState.AuthenticatedAES</code> )	Allowed	Not Allowed
Subsequent symmetric authentication (i.e. when in <code>VCState.AuthenticatedAES</code> )	Allowed, recommended not to use.	Allowed, recommended to use.

It is possible to use First Authentication when already authenticated. This can be used if the PCD does not care about interleaving attacks but rather prefers a simpler implementation. Note that the messages of the ongoing transaction are then not bound cryptographically anymore. Therefore, using First Authentication followed by Non-First Authentication is recommended. In this way, an attacker will not be able to make a PICC work with two PCDs at the same time and in that way compromise the security.

The authentication consists of two parts: [AuthenticateEV2First](#) - Part1 and [AuthenticateEV2First](#) - Part2. Detailed command definition can be found in [Section 7.3.3](#). The protocol cannot be interrupted by other commands. On any command different from [AuthenticateEV2First](#) - Part2 received after the successful execution of the first part, the PICC aborts the ongoing authentication.

During this authentication phase, the PICC accepts messages from the PCD that are longer than the lengths derived from this specification as long as `LenCap` is correct. This feature is to support the upgradability features on future product versions. The current content of `PCDcap2` shall not be interpreted by the PICC. The PCD rejects answers from the PICC when they don't have the proper length.

Upon reception of [AuthenticateEV2First](#), the PICC validates the targeted key. If the key does not exist, [AuthenticateEV2First](#) is rejected. Within the application, there are 0x05 application keys available for authentication addressed by `KeyNo` 0x00 until 0x04. Addressing other symmetric keys are only available for crypto operations with [CryptoRequest](#) and result in an error. At PICC level, there are no symmetric keys.

The PICC generates a random 16-byte challenge *RndB* and sends this encrypted to the PCD, according to [Section 6.4.6.4](#). Additionally, the PICC resets [CmdCtr](#) to zero and generate a random Transaction Identifier (TI).

If the Authentication Counter is enabled for authentication counting, it shall be incremented by 1 on successful execution of [AuthenticateEV2First](#). If the counter reaches [AuthCtrLimit](#) if enabled, any further authentication is rejected. However, once 0xFFFFFFFF is reached, the counter is not further incremented, but the authentication is still accepted.

Upon reception of the [AuthenticateEV2First](#) response from the PICC, the PCD also generates a random 16-byte challenge *RndA*. The PCD encrypts, on his turn, the concatenation of *RndA* with *RndB'*, which is the received challenge after decryption and rotating it left by one byte. Within [AuthenticateEV2First](#) - Part2, this is sent to the PICC.

Upon reception of [AuthenticateEV2First](#) - Part2, the PICC decrypts the second message and validates the received *RndB'*. If not as expected, the command is rejected. Else it generates *RndA'* by rotating left the received *RndA* by one byte. This is returned together with the generated TI. Also, the PICC sends 12 bytes of capabilities to the PCD: 6 bytes of PICC capabilities *PDcap2* and 6 bytes of PCD capabilities *PCDcap2* that were received on the command (sent back for verification).

If [AWDT1](#) is enabled, see [SetConfiguration](#), the timer is started during [AuthenticateEV2First](#) execution. If the timer expires before [AuthenticateEV2First](#) - Part2 reception, the authentication attempt is reset and the [AuthenticateEV2First](#) - Part2 will be rejected.

On successful execution of the authentication protocol, the session keys [SesAuthMACKKey](#) and [SesAuthENCKKey](#) are generated according to [Section 6.4.4.3](#). The PICC is in [VCState.AuthenticatedAES](#) and the Secure Messaging is activated. On any failure during the protocol, the PICC ends up in [VCState.NotAuthenticated](#).

If there is a mismatch between the capabilities expected by the PCD and the capabilities presented by the PICC to the PCD (both the *PDcap2* and the echoed/adjusted *PCDcap2*), it is the responsibility of the PCD to take the proper actions based on the application the PCD is running. This decision is outside the scope of this specification.

#### 6.4.4.2 Command [AuthenticateEV2NonFirst](#)

This section defines the Non-First authentication, which is recommended to be used if Secure Messaging is already active, see [Table 14](#). In this procedure both, the PICC as well as the PCD show in an encrypted way that they possess the same secret, i.e. the same key. This authentication is supported with [KeyType.AES128](#) or [KeyType.AES256](#) keys.

The authentication consists of two parts: [AuthenticateEV2NonFirst](#) - Part1 and [AuthenticateEV2NonFirst](#) - Part2. A detailed command definition can be found in [Section 7.3.4](#). This command is rejected if there is no active symmetric authentication. For the rest, the behavior is exactly the same as for [AuthenticateEV2First](#), except for the following differences:

- No *PCDcap2* and *PDcap2* are exchanged and validated.
- Transaction Identifier [TI](#) is not reset and not exchanged.
- Command Counter [CmdCtr](#) is not reset.
- If the authentication Counter is enabled for authentication counting, it shall not be incremented on [Section 7.3.4](#).

After successful authentication, the PICC remains in [VCState.AuthenticatedAES](#). On any failure during the protocol, the PICC ends up in [VCState.NotAuthenticated](#).

6.4.4.3 Session Key Generation

At the end of a valid authentication with [AuthenticateEV2First](#) or [AuthenticateEV2NonFirst](#), both the PICC and the PCD generate two session keys for secure messaging, as shown in [Figure 12](#):

- [SesAuthMACKey](#) for MACing of messages
- [SesAuthENCKey](#) for encryption and decryption of messages

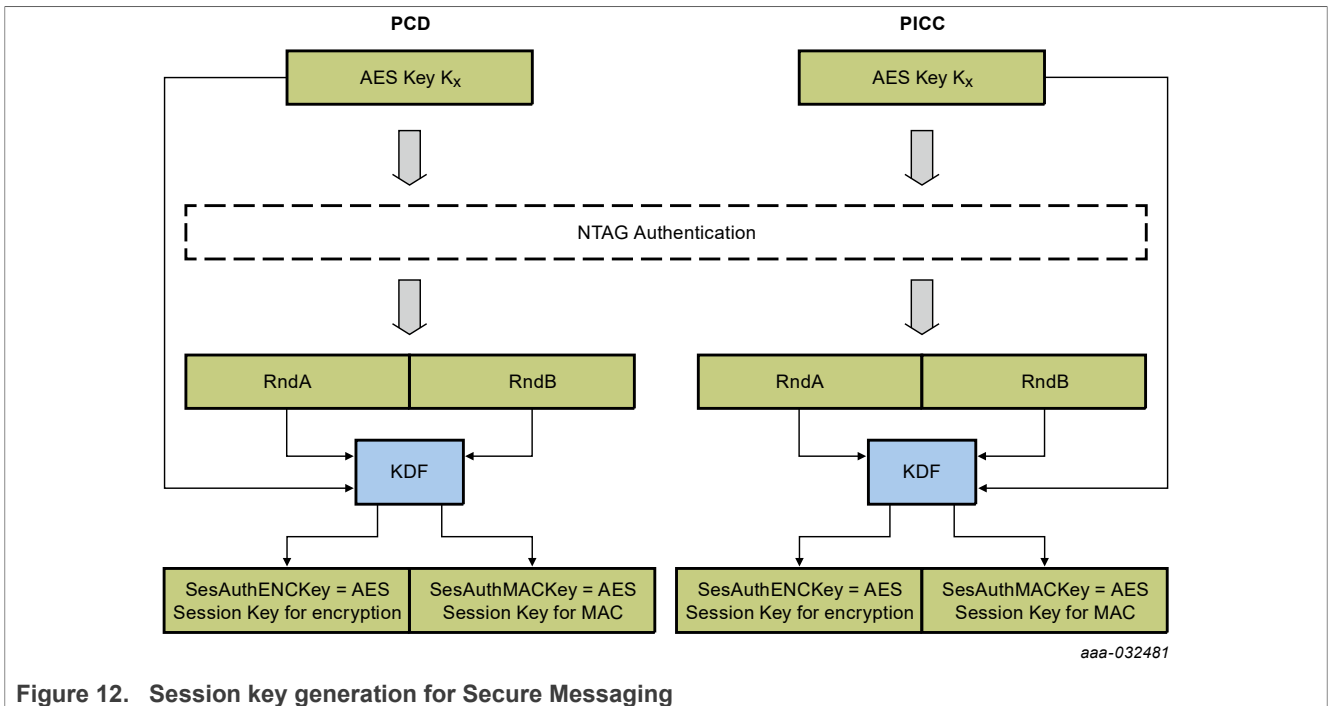

The session key generation is according to NIST SP 800-108 [10] in counter mode.

The Pseudo Random Function PRF(key; message) applied during the key generation is the CMAC algorithm described in NIST Special Publication 800-38b [8]. The key derivation key is the key Kx that was applied during authentication. If the authentication targets a KeyType.AES128 key, the generated session keys are also of KeyType.AES128. If a KeyType.AES256 authentication key is targeted, the session keys are also KeyType.AES256.

The input data is constructed using the following fields as defined by [10]. NIST SP 800-108 allows defining a different order than proposed by the standard as long as it is unambiguously defined.

- a 2-byte label, distinguishing the purpose of the key: 0x5AA5 for MACing and 0xA55A for encryption
- a 2-byte counter
  - KeyType.AES128: fixed to 0x0001.
  - KeyType.AES256: counting from 0x0001 to 0x0002.
- a 2-byte length,
  - KeyType.AES128: fixed to 0x0080.
  - KeyType.AES256: fixed to 0x0100.
- a 26-byte context, constructed using the two random numbers exchanged, RndA and RndB

**KeyType.AES128**

First, the 32-byte input session vectors  $SV_x$  are derived as follows <sup>1</sup>:

<sup>1</sup> Bytes are numbered from rightmost to leftmost i.e. index 0 for the rightmost byte.

$$SV1 = A5h||5Ah||00h||01h||00h||80h||RndA[15..14]||(RndA[13..8] \oplus RndB[15..10])||RndB[9..0]||RndA[7..0]$$

$$SV2 = 5Ah||A5h||00h||01h||00h||80h||RndA[15..14]||(RndA[13..8] \oplus RndB[15..10])||RndB[9..0]||RndA[7..0]$$

with  $\oplus$  being the XOR-operator.

Then, the 16-byte session keys are constructed as follows:

$$SesAuthENCKey = PRF(K_x, SV1)$$

$$SesAuthMACKey = PRF(K_x, SV2)$$

### KeyType.AES256

First, the 32-byte input session vectors SV x are derived as follows:

$$SV1a = 0xA5||0x5A||0x00||0x01||0x01||0x00||RndA[15..14]||(RndA[13..8] \oplus RndB[15..10])||RndB[9..0]||RndA[7..0]$$

$$SV1b = 0xA5||0x5A||0x00||0x02||0x01||0x00||RndA[15..14]||(RndA[13..8] \oplus RndB[15..10])||RndB[9..0]||RndA[7..0]$$

$$SV2a = 0x5A||0xA5||0x00||0x01||0x01||0x00||RndA[15..14]||(RndA[13..8] \oplus RndB[15..10])||RndB[9..0]||RndA[7..0]$$

$$SV2b = 0x5A||0xA5||0x00||0x02||0x01||0x00||RndA[15..14]||(RndA[13..8] \oplus RndB[15..10])||RndB[9..0]||RndA[7..0]$$

with  $\oplus$  being the XOR-operator.

Then, the 32-byte session keys are constructed as follows:

$$SesAuthENCKey = PRF(K_x, SV1a)||PRF(K_x, SV1b)$$

$$SesAuthMACKey = PRF(K_x, SV2a)||PRF(K_x, SV2b)$$

### 6.4.5 AuthenticationCounter and Limit

To allow mitigating potential future attack scenarios, symmetric mutual authentications can be configured with a counter and usage limitation. This allows limiting the amount of key computations, and therefore related trace collection for side-channel attacks. Next to attack mitigation, this feature can also be used to limit the usage of a card/device. Potentially, the limit can be increased in the field, e.g. if the end user pays for additional service.

The authentication counter and usage limitation are configured through [SetConfiguration](#) Option 0x16, by assigning one of the [FileType.Counters](#) to this purpose.

Once enabled, NTAG X DNA shall maintain a AuthCtr through the assigned file, for counting the authentications, and if configured also an AuthCtrLimit.

This means that the AuthCtr shall be incremented by the following operations, if enabled:

- [AuthenticateEV2First](#) for AES-based authentication, before the response of the Part 1.

If the configured AuthCtrLimit has been reached, the related authentication is disabled. This means that the relevant keys cannot be used anymore, though the key entry can still be updated (and potentially reenabled) if the required authentication to do so can still be gained, e.g. through an asymmetric authentication if symmetric authentication is disabled.

If the AuthCtrLimit is disabled, authentications may still be counted.

When further updating [SetConfiguration](#) Option 0x16, it is possible to disable or change the AuthCtrLimit without affecting the current AuthCtr value. This ensures the monotonic property of the [FileType.Counter](#). When configuring a different file, the authentication counting for the original file is disabled. Putting the limit to a value equal or lower than the current value will immediately disable the authentication.

As any other [SetConfiguration](#) option, the current authentication counter configuration and AuthCtrLimit can be retrieved with [GetConfiguration](#). For this Option 0x16, also the current AuthCtr value will be returned by [GetConfiguration](#).

Enabling the feature may create a denial-of-service risk. It must be assessed from a system-level perspective if this can be accepted.

### 6.4.6 EV2/AES secure messaging

The EV2 secure messaging is an AES-based secure messaging, which was introduced in MIFARE DESFire EV2, explaining the naming.

The EV2 secure messaging can both be initiated by an ECC-based mutual authentication as defined in [Section 6.4.2](#), as well as by the AES-based mutual authentication as defined in [Section 6.4.4](#).

#### 6.4.6.1 Transaction Identifier

To avoid interleaving of transactions from multiple PCDs toward one PICC, the Transaction Identifier (TI) is included in each MAC that is calculated over commands or responses. The TI is generated by the PICC and communicated to the PCD with a successful execution of an [AuthenticateEV2First](#) command, see [Section 7.3.3](#). The size is 4 bytes and these 4 bytes can hold any value. The TI is treated as a byte array, so there is no notion of MSB and LSB.

In the case of ECC-based authentication it is expected that a transaction only consists of a single authentication. As a [CARootKey](#) and/or reader certificate can cover multiple access rights, see [Section 6.5](#), there should not be a need to authenticate multiple times. Therefore, in VCState.AuthenticatedECC, the TI is set to all zero bytes.

#### 6.4.6.2 Command Counter

A command counter is included in the MAC calculation for commands and responses to prevent e.g. replay attacks. It is also used to construct the Initialization Vector (IV) for encryption and decryption.

Each command, besides few exceptions, see below, is counted by the command counter CmdCtr, which is a 16-bit unsigned integer. Both sides count commands, so the actual value of the CmdCtr is never transmitted. The CmdCtr is reset to 0x0000 at PCD and PICC after a successful [AuthenticateEV2First](#) authentication and it is maintained as long as the PICC remains authenticated. In cryptographic calculations, the CmdCtr is represented LSB first. Subsequent authentications using [AuthenticateEV2NonFirst](#) do not affect the CmdCtr. Subsequent authentications using the [AuthenticateEV2First](#) will reset the CmdCtr to 0x0000.

In the case of ECC-based authentication, the CmdCtr is also set to 0x0000 after successful authentication, i.e. a [ISOGeneralAuthenticate](#) exchange successfully completing SIGMA-I mutual authentication.

The CmdCtr is increased between the command and response, for all communication modes.

For [CommMode.Plain](#), this is not reflected in the actual command exchange as the CmdCtr is not used.

When a MAC on a command is calculated at PCD side that includes the CmdCtr, it uses the current CmdCtr. The CmdCtr is afterward incremented by 1. At PICC side, a MAC appended to received commands is checked using the current value of CmdCtr. If the MAC matches, CmdCtr is incremented by 1 after successful reception of the command, and before sending a response.

For [CommMode.Full](#), the same holds for both the MAC and encryption IV calculation, i.e. the nonincreased value is used for the command calculations while the increased value is used for the response calculations.

If the CmdCtr holds the value 0xFFFF and a command maintaining the active authentication arrives at the PICC. This leads to an error response and the command is handled like the MAC was wrong.

Command chaining, see [Section 6.3.3](#), does not affect the counter. The chained command is considered as a single command, just as for the other aspects of secure messaging, and therefore the related counter is increased only once.

### 6.4.6.3 MAC Calculation

MACs are calculated using the underlying block cipher according to the CMAC standard described in [\[8\]](#). Padding is applied according to the standard.

The MAC used in NTAG X DNA is truncated by using only the 8 even-numbered bytes out of the 16-bytes output as described [\[8\]](#) when represented in most-to-least-significant order.

### Initialization vector for MACing

The initialization vector used for the CMAC computation is the zero-byte IV as prescribed [\[8\]](#).

### 6.4.6.4 Encryption

Encryption and decryption are calculated using AES according to the CBC mode of NIST SP800-38a [\[7\]](#).

Padding is applied according to Padding Method 2 of ISO/IEC 9797-1 [\[9\]](#), i.e. by always adding 0x80 followed. If required, by zero bytes until a string with a length of a multiple of 16 byte is obtained. If the plain data is a multiple of 16 bytes already, an additional padding block is added. The only exception is during the authentication itself ([AuthenticateEV2First](#) and [AuthenticateEV2NonFirst](#)), where no padding is applied at all.

The notation  $E(key, message)$  is used to denote the encryption and  $D(key, message)$  for decryption.

### Initialization Vector for Encryption

When encryption is applied to the data sent between the PCD and the PICC, the Initialization Vector (IV) is constructed by encrypting with `SesAuthENCKey` according to the ECB mode of NIST SP800-38a [\[7\]](#) the concatenation of:

- a 2-byte label, distinguishing the purpose of the IV: 0xA55A for commands and 0x5AA5 for responses
- Transaction Identifier [TI](#)
- Command Counter [CmdCtr](#) (LSB first)
- Padding of zeros acc. to NIST SP800-38b [\[8\]](#)

This results in the following IVs:

IV for CmdData =  $E(\text{SesAuthENCKey}; 0xA5 \parallel 0x5A \parallel \text{TI} \parallel \text{CmdCtr} \parallel 0x0000000000000000)$

IV for RespData =  $E(\text{SesAuthENCKey}; 5Ah \parallel 0xA5 \parallel \text{TI} \parallel \text{CmdCtr} \parallel 0x0000000000000000)$

When an encryption or decryption is calculated, the [CmdCtr](#) to be used in the IV are the current values. This means that if [CmdCtr](#) =  $n$  before the reception of a command, after the validation of the command [CmdCtr](#) =  $n + 1$  and that value will be used in the IV for the encryption of the response.

For the encryption during authentication (both [AuthenticateEV2First](#) and [AuthenticateEV2NonFirst](#)), the IV is 128 bits of 0.

### 6.4.6.5 Session Key Generation

As an output of a successful authentication, both the PICC and the PCD have generated two session keys for secure messaging:

- [SesAuthMACKey](#) or `KSesAuthMAC` for MACing of messages
- [SesAuthENCKey](#) or `KSesAuthENC` for encryption and decryption of messages

These session keys are generated differently, depending on the authentication:

- For ECC-based authentication, this is defined in [Section 6.4.2](#).
- For AES-based authentication, this is defined in [Section 6.4.4](#).

**6.4.6.6 Communication Modes**

NTAG X DNA supports three communication modes as defined in [Table 15](#). As shown in the table, the different communication modes are represented by two bits. This representation is used at several places in the document.

**Table 15. Supported communication modes**

Communication Mode	Bit Representation	Explanation
CommMode.Plain	X0	No protection: message is transmitted in clear
CommMode.MAC	01	MAC protection for integrity and authenticity
CommMode.Full	11	Full protection for integrity, authenticity, and confidentiality

The communication mode defines the level of security for the communication as further explained in the next subsections.

**6.4.6.7 Plain Communication Mode**

The command and response data is not secured. The data is sent in plain, see [Figure 13](#), i.e. as defined in the command specification tables, see [Section 7](#).

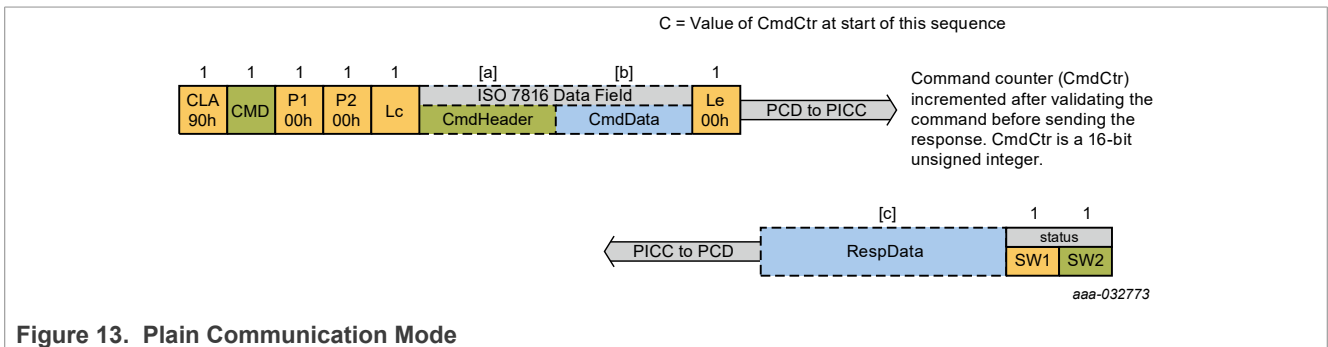

**Figure 13. Plain Communication Mode**

However, as the PICC is in authenticated state, the command counter CmdCtr is still increased as defined in [Section 6.4.6.2](#).

This allows the PCD and PICC to detect any insertion and/or deletion of commands sent in [CommMode.Plain](#) on any subsequent command that is sent in [CommMode.MAC](#) or [CommMode.Full](#).

**6.4.6.8 MAC Communication Mode**

The Secure Messaging applies MAC to all commands listed as such in [Section 7.2](#).

In the case MAC is to be applied, the following holds. The MAC is calculated using the current session key [SesAuthMACKey](#). MAC calculation is done as defined in [Section 6.4.6.3](#).

For commands, the MAC is calculated over the following data (according to the definitions from [Section 6.3.1](#)) in this order:

- Cmd
- Command Counter [CmdCtr](#)

- Transaction Identifier [TI](#)
- Command header - CmdHeader (if present)
- Command data - CmdData (if present)

For responses, the MAC is calculated over the following data in this order:

- Return code - RC
- Command Counter - [CmdCtr](#) (The already increased value)
- Transaction Identifier - [TI](#)
- Response data - RespData (if present)

CmdCtr is the Command Counter as defined in [Section 6.4.6.2](#). The CmdCtr is increased between the computation of the MAC on the command and the MAC on the response. TI is the Transaction Identifier, as defined in [Section 6.4.6.1](#). The other input parameters are as defined in [Section 6.3.1](#). The calculation is illustrated in [Figure 14](#).

In case of command chaining, the MAC calculation is not interrupted. The MAC is calculated over the data including the complete data field (i.e. either CmdData or RespData of all frames) at once. The MAC is always transmitted by appending to the unpadding plain command. If necessary, an additional frame is sent. If a MAC over the command is received, the PICC verifies the MAC and rejects commands that do not contain a valid MAC by returning INTEGRITY\_ERROR.

In this case, the ongoing command and transaction are aborted (see also [Section 7](#)). The authentication state is immediately lost and the error return code is sent without a MAC appended. Any other error during the command execution has the same consequences.

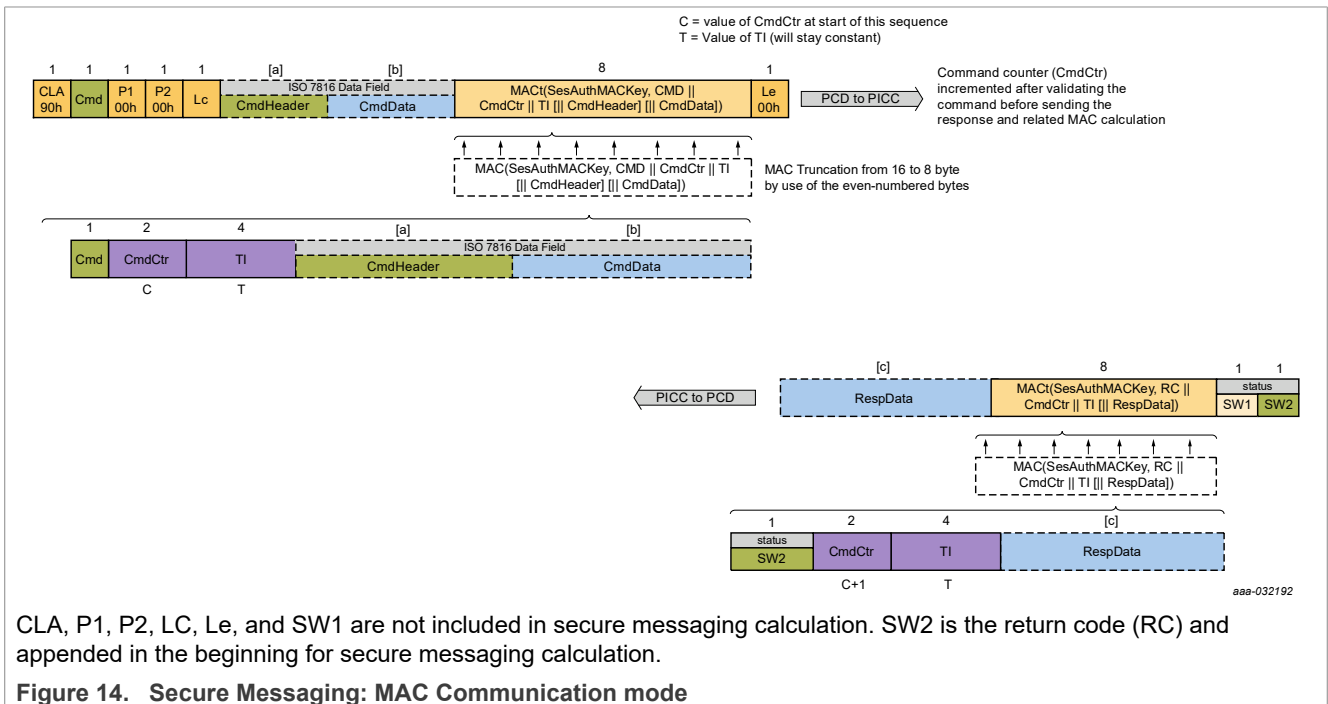

CLA, P1, P2, LC, Le, and SW1 are not included in secure messaging calculation. SW2 is the return code (RC) and appended in the beginning for secure messaging calculation.

Figure 14. Secure Messaging: MAC Communication mode

### 6.4.6.9 Full Communication Mode

The Secure Messaging applies encryption ([CommMode.Full](#)) to all commands listed as such in [Section 7.2](#). In the case [CommMode.Full](#) is to be applied, the following holds. The encryption/decryption is calculated using the current session key SesAuthENCKey. Calculation is done as defined in [Section 6.4.6.4](#) over either the command or the response data field (i.e. CmdData or RespData). None of the commands have a data field in both the command and the response frame.

After the encryption, the command and response frames are handled as with MAC. This means that additionally a MAC is calculated and appended for transmission using the current session key [SesAuthMACKey](#). This is exactly done as specified for MAC in [Section 6.4.6.8](#), replacing the plain CmdData or RespData by the encrypted field:  $E(\text{SesAuthENCKey}; \text{CmdData})$  or  $E(\text{SesAuthENCKey}; \text{RespData})$ . The complete calculation is illustrated in [Figure 15](#). In the case of command chaining, the encryption/decryption is applied over the complete data field (i.e. of all frames). If necessary, due to the padding or the MAC added, an additional frame is sent. If encryption of the command is required, after the MAC verification as described for MAC, the PICC verifies and removes the padding bytes. Commands without a valid padding are also rejected by returning INTEGRITY\_ERROR.

In this case, the ongoing command and transaction are aborted (see also [Section 7](#)). The authentication state is immediately lost and the error return code is sent without a MAC appended. Any other error during the command execution has the same consequences.

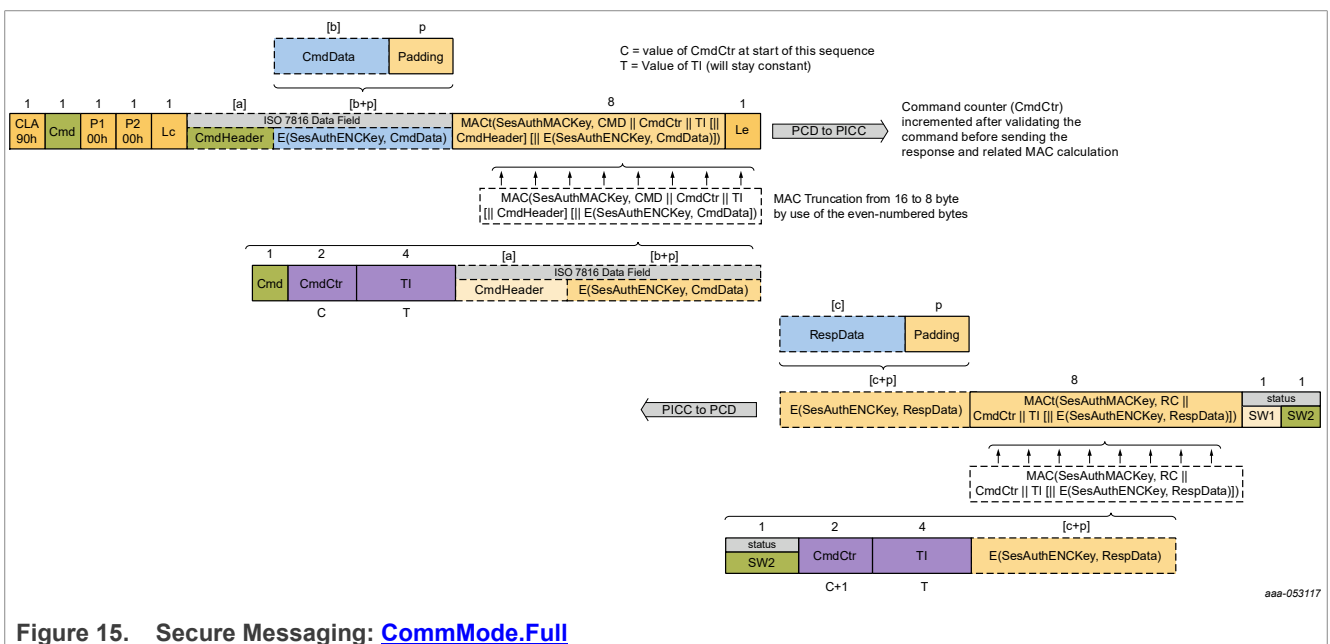

Figure 15. Secure Messaging: [CommMode.Full](#)

### 6.4.7 Controller Session Key Usage

As described in [Section 6.4.2](#), NTAG X DNA supports both the initiator and responder roles of SIGMA-I for the ECC-based mutual authentication. This may open up use case where NTAG X DNA is used in both the verifier (controller in I<sup>2</sup>C or PICC in ISO/IEC 14443-4 context) and prover device (target in I<sup>2</sup>C or PICC in ISO/IEC 14443-4 context). For example, this can be a host device and consumable parts.

For these use cases, NTAG X DNA supports [ProcessSM](#), to allow command generation, i.e. applying the required secure messaging, and response processing, i.e. validating the MAC and eventually decrypting.

Support of [ProcessSM](#) must be explicitly enabled through [SetConfiguration](#) Option 0x0F and/or 0x10 for NFC and I<sup>2</sup>C interfaces respectively, by setting bit 7 of the ProtocolOptions. By default, [ProcessSM](#) is disabled for both interfaces. The typical use case requires this only over the I<sup>2</sup>C interface.

#### 6.4.7.1 ProcessSM

If [ProcessSM](#) is enabled, it is only supported in VCState.AuthenticatedECC (see [Section 6.4.1](#)). In other states, the command is rejected.

The [ProcessSM](#) supports two variants:

- [ProcessSM\\_Apply](#): applying secure messaging to a command.
- [ProcessSM\\_Remove](#): removing secure messaging from a response.

The overall command format is outlined in [Section 7.3.5](#) while the two variants are further detailed in the following subsections.

While the [ProcessSM](#) is issued in VCState.AuthenticatedECC, the command itself is not protected by the regular secure messaging. This means both the command and response are issued in plain, just applying the secure messaging to the command and response data to support controller device processing.

Once enabled, there is no additional access control to the [ProcessSM](#) command. Therefore, it must be assessed at system level if the access to the command can be abused.

#### 6.4.7.2 [ProcessSM\\_Apply](#)

The [ProcessSM\\_Apply](#) is used for applying secure messaging to a command before sending it to the target device. The command format is outlined in [Section 7.3.6](#).

If targeting [CommMode.Plain](#), there is no command data exchanged. NTAG X DNA increments the [CmdCtr](#) by the amount given in [CmdCtrIncr](#). If [CmdCtr](#) would reach 0xFFFF or overflow, the command is rejected.

If targeting [CommMode.MAC](#) or [CommMode.Full](#), [Plaintext](#) provides the data to be protected. [ProcessSM\\_Apply](#) only supports one-shot operations fitting in a single short-length ISO/IEC 7816-4 APDU. Bigger lengths are rejected. The data provided and returned by NTAG X DNA does not hold the ISO/IEC 7816-4 APDU wrapping overhead. This means the native command fields, as described in [Section 6.3.1](#) consisting of Cmd (i.e. the ISO/IEC 7816-4 INS field) followed by eventually CmdHeader and CmdData fields (i.e. the full ISO/IEC 7816-4 Command Data field).

If targeting [CommMode.Full](#), an additional parameter [Offset](#) indicates where the encryption shall start, i.e. the first byte of CmdData.

If targeting [CommMode.MAC](#), only the computed MAC is returned. If targeting [CommMode.Full](#), the encrypted data is returned together with the computed MAC. Other plain data like the Cmd and CmdHeader are not echoed.

#### 6.4.7.3 [ProcessSM\\_Remove](#)

The [ProcessSM\\_Remove](#) is used for removing and validating secure messaging from a response received from a target device. The command format is outlined in [Section 7.3.7](#).

If targeting [CommMode.Plain](#), the command must not be called as the only relevant processing ([CmdCtr](#)), is triggered with [ProcessSM\\_Apply](#).

If targeting [CommMode.MAC](#) or [CommMode.Full](#), [Ciphertext](#) provides the data to be processed. Note that [ProcessSM\\_Remove](#) only supports one-shot operations fitting in a single short-length ISO/IEC 7816-4 APDU. Bigger lengths are rejected. The data provided and returned by NTAG X DNA does not hold the ISO/IEC 7816-4 APDU wrapping overhead. This means the native response fields, as described in [Section 6.3.1](#) consisting of RC (i.e. the ISO/IEC 7816-4 SW2 field) followed by eventually RespData and the MAC (i.e. the full received ISO/IEC 7816-4 Response Data field). In [CommMode.Full](#), RespData is the encrypted response data.

If targeting [CommMode.MAC](#), no data is returned. If targeting [CommMode.Full](#), the decrypted data is returned. The RC is not echoed.

### 6.4.8 Secure Dynamic Messaging

The Secure Dynamic Messaging (SDM) allows for confidential and integrity-protected data exchange, without requiring a preceding authentication. NTAG X DNA supports SDM for reading from one of the StandardData files on the PICC. Secure Dynamic Messaging allows adding security to the data read, while still being able to

access it with standard NDEF readers. The typical use case is an NDEF holding a URI and some metadata, where SDM allows this metadata to be communicated confidentiality and integrity protected toward a back end server.

When using SDM, residual risks coming with the Secure Dynamic Messaging for Reading have to be taken into account. As SDM allows free reading of the secured message, i.e. without any up-front reader authentication, anybody can read out the message. This means that also a potential attacker is able to read out and store one or multiple messages, and play them at a later point in time to the verifier.

If this residual risk is not acceptable for the system's use case, one of the authentication protocols (using challenge response protocol) and subsequent secure messaging should be applied. This would require using an own application and operating outside a standard NDEF read operation.

Other risk mitigation may be applied for SDM to limit the residual risk, without completely removing it:

- Track SDMReadCtr per tag at the verifying side. Reject SDMReadCtr values that have been seen before or that are played out-of-order. This is a minimum requirement that any verifier should implement.
- Limit the time window of an attacker by requiring tags to be presented regularly (e.g. at least once a day) in combination with the previous mitigation.
- Read out the SDM-protected file more than once. This does not protect against attackers that have read out the valid tag also multiple times and play the received responses in the same sequence. NTAG X DNA supports two modes for integrity protection and authentication of the data:

NTAG X DNA supports two modes for integrity protection and authentication of the data:

- symmetric SDMMAC, where the data is protected by a Message Authentication Code, which is generated by a symmetric AES key. This is specified in [Section 6.4.8.8](#) and [Section 6.4.8.9](#).
- asymmetric SDMSIG, where the data is protected by a Signature, which is generated with the private key of an ECC key pair. This is specified in [Section 6.4.8.10](#) and [Section 6.4.8.11](#). This approach may ease the key management towards e.g. reader infrastructure as no secret key is required for the signature validation.

Encryption is always based on symmetric cryptography, as specified in [Section 6.4.8.4](#) for PICCData like the UID and [Section 6.4.8.7](#) for generic file data (SDMENCFileData).

The session key derivation for symmetric keys (be it for encryption or MACing) is outlined in [Section 6.4.8.12](#).

SDM is enabled and configured with [ChangeFileSettings](#), see [Section 6.11.2.3](#). Access right related aspects are defined in [Section 6.11.2.1](#).

### 6.4.8.1 SDM Read Counter

To allow replay detection by the party validating the data read, a read counter is associated with the file for which Secure Dynamic Messaging is enabled.

SDMReadCtr is a 24-bit unsigned integer. The SDMReadCtr is reset to 0x000000 when enabling SDM with [ChangeFileSettings](#). In cryptographic calculations and represented with binary encoding on the external interface, the SDMReadCtr is represented LSB first. When represented with ASCII encoding on the contactless interface, it is represented MSB first. This is in line with the NFC counter representation in [\[14\]](#).

In not Authenticated state, the SDMReadCtr is incremented by 1 before calculating the response of the first read command, [ReadData](#) or [ISOReadBinary](#), if successful. On subsequent read commands targeting the same file, the SDMReadCtr is not increased, and the current value is used. As soon as a different command has been received, the counter is incremented again on a subsequent read command. Also when varying between [ReadData](#) and [ISOReadBinary](#), the counter is incremented on each first instance of the read command type. The SDMReadCtr is not incremented when authenticated.

If the SDMReadCtr reaches the SDMReadCtrLimit (see [Section 6.4.8.2](#)) or the value 0xFFFFFFFF (if SDMReadCtrLimit is not enabled) and a first read command arrives at the PICC, an error is being returned.

Command chaining, see [Section 6.3.3](#), does not additionally affect the counter increase. The chained command is considered as a single command.

SDMReadCtr can be retrieved via the mirroring as part of the PICCData, see [Section 6.4.8.3](#), or it can be retrieved via [GetFileCounters](#).

**6.4.8.2 SDM Read Counter Limit**

To allow limiting the number of reads that can be done with a single device applying Secure Dynamic Messaging, an optional SDM Read Counter Limit can be configured. There are two main use cases:

- Limit the number of usages from the card side. Typically this can also be controlled from the back end verifying the SDM for Read protected message.
- Limit the number of traces that can be collected on the symmetric crypto processing. This way the attack potential via side-channel attacks can be further reduced.

The number of reads that can be executed for an SDM configured file can be limited by setting an SDM Read Counter Limit (SDMReadCtrLimit). This is an unsigned integer of 3 bytes, related with SDMReadCtr. On the interface, the SDMReadCtrLimit is represented LSB first. The SDMReadCtrLimit can be enabled by setting a customized value with [ChangeFileSettings](#). It can be retrieved with [GetFileSettings](#).

Once the SDMReadCtr equals the SDMReadCtrLimit, no reading of the file with [ReadData](#) or [ISOReadBinary](#) in not authenticated state can be executed. If authenticated, reading is always possible even if SDMReadCtrLimit is reached, applying the regular secure messaging. If the SDMReadCtrLimit is disabled with [ChangeFileSettings](#), this is also equivalent to putting it to the maximum value: 0xFFFFFFFF.

**6.4.8.3 PICCData**

The PICCData holds metadata of the targeted PICC and file, consisting of the UID and/or the SDMReadCtr. Whether PICCData is transmitted in plain or encrypted depends on the configuration of the SDMMetaRead access rights on the file, see [Section 7](#). If the SDMMetaRead access right is configured for free access (0xE), PICCData is plain and is defined according to [Table 16](#).

ASCII mirroring is reflected by the function EncodeASCII(), which means that each hexadecimal character of the hexadecimal representation will be ASCII encoded using capitals. For example, the UID 0x04E141124C2880 becomes: 0x30 34h 0x45 31h 0x34 31h 0x31 32h 0x34 43h 0x32 38h 0x38 30h.

**Table 16. PICCData: plain encoding and lengths**

Mode	PICCData Value	Length with 7-byte UID
ASCII	EncodeASCII(UID)	UIDLength = 14 (i.e. 2*UIDLen)
ASCII	EncodeASCII(SDMReadCtr)	SDMReadCtrLength = 6 (i.e. 2 × 3)

The SDMReadCtr, as defined in [Section 6.4.8.1](#), is represented MSB first for the ASCII case. If the SDMMetaRead access right is configured for an application key, PICCData is encrypted as defined in [Section 6.4.8.4](#). In this case, the input plaintext for the encryption is always in binary encoding, while the output ciphertext will be ASCII encoded.

The PICCData is mirrored within the file. This is configured with [ChangeFileSettings](#) via the related offsets.

In the case of plain mirroring (i.e. access right SDMMetaRead = 0xE):

- UIDOffset configures the UID mirroring position. It is only given if UID mirroring is enabled.
- SDMReadCtrOffset configures the SDMReadCtr mirroring position. It is only given if SDMReadCtr mirroring is enabled. It is possible to enable the SDMReadCtr but without mirroring by putting SDMReadCtrOffset to 0xFFFFFFFF. In this case, it can be retrieved with the [GetFileCounters](#) command.

If UID and SDMReadCtr are mirrored within the file, they shall not overlap:

- $UIDOffset \geq SDMReadCtrOffset + SDMReadCtrLength$  OR  $SDMReadCtrOffset \geq UIDOffset + UIDLength$ .

In the case of encrypted mirroring (i.e.  $SDMMetaRead = 0x0..0x4$ ),  $PICCCDataOffset$  configures the  $PICCCData$  mirroring. The encryption is outlined in [Section 6.4.8.4](#).

If the  $PICCCData$  is mirrored within the file, the mirroring shall always be applied in not authenticated state, independently of whether Secure Dynamic Messaging applies. This means it will also be applied if reading the file with free access due to Read or ReadWrite access right. If authenticated, no mirroring is done, i.e. the regular secure messaging is always applied on the static file data.

With NTAG X DNA,  $PICCCData$  is always ASCII encoded.

### 6.4.8.4 Encryption of PICCCData

In the case of encrypted  $PICCCData$  mirroring (both binary and ASCII),  $PICCCDataTag$  specifies what metadata is mirrored, together with the length of the UID if mirrored, as defined in [Table 17](#).

Table 17.  $PICCCDataTag$

Bit	Value	Description
Bit 7	-	UID mirroring
	0	disabled
	1	enabled
Bit 6	-	$SDMReadCtr$ mirroring
	0	disabled
	1	enabled
Bit 5-4	00	RFU
Bit 3-0	-	UID Length
	0x0	RFU (if UID is not mirrored)
	0x7	7 byte UID

The format of the plain text is:  $PICCCDataTag [ || UID ] [ || SDMReadCtr ]$ .

To ensure that the encrypted  $PICCCData$  cannot be abused for tracking purposes, random padding is added to the actual plain text input.

The random padding is generated for the response of the first read command, [ReadData](#) or [ISOReadBinary](#). On subsequent read commands targeting the same file the same random padding is reused. This allows for reading the file in chunks, where a chunk border might even be in the middle of the encrypted  $PICCCData$ . As soon as a different command has been received, fresh random padding is generated on a subsequent read command. Also when varying between [ReadData](#) and [ISOReadBinary](#), fresh random padding is generated.

The key applied for encryption of  $PICCCData$  is the [SDMMetaReadKey](#) as defined by the  $SDMMetaRead$  access right.

#### 6.4.8.4.1 AES mode encryption

Encryption and decryption of the  $PICCCData$  are calculated using the underlying block cipher according to the CBC mode of NIST SP800-38a [\[7\]](#), applying zero-byte IV.

NTAG X DNA supports AES-128 and AES-256 as the underlying block cipher depending on the key type of the [SDMMetaReadKey](#).

Therefore,  $PICCCData$  is defined as follows:

$PICCData = E(SDMMetaReadKey; PICCDataTag [ || UID ] [ || SDMReadCtr ] || RandomPadding)$  with  $PICCDataTag$  as defined in [Section 6.4.8.3](#), and  $RandomPadding$  being a random byte string generated by the PICC to make the input 16 bytes long. Because of the ASCII encoding, the required placeholder length doubles.

#### 6.4.8.5 GPIOStatus

When one of the GPIO pins is configured for input, see [Section 6.14](#), or tag tamper detection, see [Section 6.15](#), with [SetConfiguration](#) 0x11, see [Section 6.4.8.5](#), it is possible to mirror the statuses within the NDEF file.

The GPIO statuses are encoded on a 3-byte string, identical as the [ReadGPIO](#) response, see [Section 6.11.2.3](#) and especially [Table 258](#).

They can be mirrored in plain or encrypted. For the latter,  $GPIOStatus$  needs to be positioned within the placeholder for the plain data that serves as input for  $SDMENCFileData$ , see [Section 6.4.8.6](#). In this case, the static file data is replaced by the dynamic statuses before applying the encryption. Note however, that either all status bytes are plain, or all are encrypted.

As the status bytes are already ASCII encoded, no ASCII encoding must be applied on top, and only a 3-byte placeholder is required. Where the status is mirrored within the file, is configured with [ChangeFileSettings](#), see [Section 6.11.2.3](#) via  $GPIOStatus$ . The restrictions on this offset shall be that it may not be overlapped with any  $PICCData$  mirrored or with the [SDMMAC](#).

If the  $GPIOStatus$  is mirrored within the file, the mirroring shall always be applied in [VCState.NotAuthenticated](#), independently of whether Secure Dynamic Messaging applies. This means it will also be applied if reading the file with free access due to [FileAR.Read](#) or [FileAR.ReadWrite](#). If authenticated, i.e. in [VCState.AuthenticatedAES](#) or [VCState.AuthenticatedECC](#), no mirroring is done, i.e. the regular secure messaging is always applied on the static file data.

#### 6.4.8.6 SDMENCFileData

SDM for Reading supports mirroring (part of the) file data encrypted. This part is called the  $SDMENCFileData$ .

If the  $SDMFileRead$  access right is configured for an application key, part of the file data can optionally be encrypted as defined in [Section 6.4.8.7](#) when being read out in not authenticated state.

In this case, the input plaintext for the encryption is always in binary encoding, while the output ciphertext is ASCII encoded.

If authenticated, no Secure Dynamic Messaging is applied, i.e. the regular secure messaging is always applied on the static file data.

The  $SDMENCFileData$  (if any) is always mirrored within the file. This is configured with [ChangeFileSettings](#), see [Section 7.8.7](#) via  $SDMENCOffset$  and  $SDMENCLength$ . If the  $SDMFileRead$  access right is disabling Secure Dynamic Messaging for reading (i.e. set to 0xF),  $SDMENCOffset$  and  $SDMENCLength$  are not present in [ChangeFileSettings](#).

If  $PICCData$  is mirrored within the file,  $SDMENCFileData$  shall not overlap with it. Depending on what is exactly mirrored, the following holds:

- $SDMENCOffset \geq PICCDataOffset + PICCDataLength$  OR  $PICCDataOffset \geq SDMENCOffset + SDMENCLength$ .
- $SDMENCOffset \geq UIDOffset + UIDLength$  OR  $UIDOffset \geq SDMENCOffset + SDMENCLength$ .
- $SDMENCOffset \geq SDMReadCtrOffset + SDMReadCtrLength$  OR  $SDMReadCtrOffset \geq SDMENCOffset + SDMENCLength$ .

It is ensured that  $SDMENCOffset + SDMENCLength$  is smaller than or equal to the file size. As the  $SDMMAC$  is as well mirrored into the file, additional conditions apply, see [Section 6.4.8.8](#). The  $SDMENCLength$  is a multiple of 32 bytes for the ASCII encoding. With NTAG X DNA, only ASCII encoding is supported.

### 6.4.8.7 Encryption of SDMENCFIData

The key applied for the encryption is a session key [SesSDMFileReadENCKey](#) derived from the application key defined by the SDMFileRead access right as specified in [Section 6.4.8.12](#).

From the user point of view, the SDMENCOffset and SDMENCLength define a placeholder within the file where the plain data is to be stored when writing the file.

For ASCII encoding, only the first half of the placeholder is used for storing the plain data. The second half is ignored for constructing the returned data when reading with SDM. For example, if targeting to encrypt 2 AES blocks, i.e. 32 bytes, a placeholder of 64 bytes is reserved via SDMENCOffset and SDMENCLength. The first 32 bytes hold the plaintext, and the next 32 bytes are ignored when reading with Secure Dynamic Messaging.

#### 6.4.8.7.1 AES mode encryption

Encryption and decryption of the SDMENCFIData are calculated using the underlying block cipher according to the CBC mode of NIST SP800-38a [\[7\]](#).

NTAG X DNA supports AES-128 and AES-256 as the underlying block cipher depending on the key type of the [SDMFileReadKey](#).

The following IV is applied:

$IV = E(\text{SesSDMFileReadENCKey}; \text{SDMReadCtr} || 0x00000000000000000000000000000000)$  with SDMReadCtr LSB first.

For applying SDM with ASCII encoding, the SDMENCFIData is defined as follows:

$SDMENCFIData = E(\text{SesSDMFileReadENCKey}; \text{StaticFileData}[\text{SDMENCOffset}:: \text{SDMENCOffset} + \text{SDMENCLength} - 1])$  with StaticFileData being the current file data as written in the placeholder. The file configuration ensures via SDMENCLength that the input is a multiple of 16 bytes, so no padding is applied.

It is possible via the read command parameters to read-only part of the file. If the SDMENCFIData is partially read as per the issued offset and length, a truncated part of the ciphertext is returned. As truncation might happen in the middle of an AES block. This means subsequent read commands to fetch the remainder of the file might be required to be able to decrypt.

### 6.4.8.8 SDMMAC

SDM for Reading supports calculating a MAC over the response data. This message authentication code is called the SDMMAC.

If FileAR.SDMFileRead is configured for an application key, and FileAR.SDMFileRead2 is set to 0xF, a MAC is calculated as defined in [Section 6.4.8.9](#) when being read out in no authenticated state.

The SDMMAC is to be mirrored within the file via SDMMACOffset. This is configured with [ChangeFileSettings](#), see [Section 7.8.7](#).

If SDMMAC is mirrored within the file, it is limited to start only after SDMENCFIData, i.e.  $\text{SDMMACOffset} \geq \text{SDMENCOffset} + \text{SDMENCLength}$ . The SDMMACInputOffset must ensure that the complete SDMENCFIData is included in the MAC calculation.

As the mirrored SDMMAC is ASCII encoded, the output size doubles to 16 bytes.

It is ensured that  $\text{SDMMACOffset} + \text{SDMMACLength}$  is smaller or equal than the file size. If authenticated, no Secure Dynamic Messaging is applied and the placeholder data at SDMMACOffset is not replaced, i.e. the regular secure messaging is always applied on the static file data.

The SDMMACInputOffset defines from which position in the file the MAC calculation starts. If SDMMAC is mirrored within the file, SDMMACInputOffset must be smaller than or equal to SDMMACOffset.

MACing is mandatory if the `SDMFileRead` access right is configured for an application key. If the `SDMFileRead` access right is disabling Secure Dynamic Messaging for reading (i.e. set to `0xF`), `SDMMACOffset` and `SDMMACInputOffset` are not present in [ChangeFileSettings](#).

With NTAG X DNA, only ASCII encoding is supported. SDMMAC is always mirrored within the file.

### 6.4.8.9 MAC Calculation

The key applied for the MAC calculation is a session key [SesSDMFileReadMACKey](#) derived from the application key defined by the `SDMFileRead` access right, as specified in [Section 6.4.8.12](#).

#### 6.4.8.9.1 AES mode MAC calculation

The 8-byte SDMMAC is calculated using AES according to the CMAC standard described in NIST Special Publication 800-38b [8] applying the same truncation as the AES mode secure messaging, see [Section 6.4.6.3](#).

NTAG X DNA supports AES-128 and AES-256 as the underlying block cipher depending on the key type of the [SDMFileReadKey](#).

The SDMMAC is defined as follows:

$SDMMAC = MAC_t(\text{SesSDMFileReadMACKey}; \text{DynamicFileData}[\text{SDMMACInputOffset} \dots \text{SDMMACOffset} - 1])$  with `DynamicFileData` being the file data as how it is put on the contactless interface, i.e. replacing any placeholders by the dynamic data.

#### 6.4.8.10 SDMSIG

If [FileAR.SDMFileRead2](#) is configured for an application [ECCPrivateKey](#), a signature, called SDMSIG, is calculated as defined in [Section 6.4.8.11](#) when being read out in [VCState.NotAuthenticated](#). If the targeted [ECCPrivateKey](#) does not exist or is not enabled for ECC-based Secure Dynamic Messaging (via its key policy or if `KeyUsageCtrlLimit` was already reached, see [Section 6.8.1.2](#)), the read command is rejected.

The offsets for signature input and signature mirroring are configured with [ChangeFileSettings](#), see [Section 6.11.2.3](#). As to a large extent the same rules apply, parameters [SDMMACOffset](#) and [SDMMACInputOffset](#) are reused.

This means that the SDMSIG is to be mirrored within the file via [SDMMACOffset](#). It shall be limited to start only after [SDMENCFileData](#), i.e.  $SDMMACOffset \geq SDMENCOffset + SDMENCLength$ . The `SDMMACInputOffset` must ensure that the complete `SDMENCFileData` is included in the signature calculation. The `SDMSIGLength` is 128 bytes, as only ASCII encoding is supported. It shall be ensured that  $SDMMACOffset + SDMSIGLength$  is smaller or equal than the file size.

Also here, if authenticated, no Secure Dynamic Messaging is applied and the placeholder data at `SDMMACOffset` is not replaced, i.e. the regular secure messaging is always applied on the static file data.

The `SDMMACInputOffset` defines from which position in the file the input for the signature calculation starts. With NTAG X DNA, only ASCII encoding is supported. SDMSIG shall always be mirrored within the file.

#### 6.4.8.11 Signature Calculation

The key applied for the signature calculation is the [ECCPrivateKey](#) defined by [FileAR.SDMFileRead2](#).

The [SDMSIG](#) is calculated using ECDSA Digital Signature Generation as defined in [\[13\]](#). The hash function to be applied is SHA-256, as specified in NIST FIPS 180-4[\[19\]](#).

SDMSIG is defined as follows:

$$SDMSIG = ECDSA_{Sign}(Priv.x, DynamicFileData[SDMMACInputOffset..SDMMACOffset - 1])$$

with *DynamicFileData* being the file data as how it is put on the external interface, i.e. replacing any placeholders by the dynamic data.

#### 6.4.8.12 SDM Session Key Generation

For Secure Dynamic Messaging for reading, the following session keys are calculated:

- [SesSDMFileReadMACKey](#) for MACing of file data.
- [SesSDMFileReadENCKey](#) for encryption of file data

The session key generation is according to NIST SP 800-108 [\[10\]](#) in counter mode.

The pseudo-random function applied during the key generation is the CMAC algorithm described in NIST Special Publication 800-38b [\[8\]](#). The key derivation key is the [SDMFileReadKey](#) as configured with the [SDMFileRead](#) access right.

##### 6.4.8.12.1 AES mode session key generation for SDM

The input data is constructed using the following fields as defined by [\[10\]](#). NIST SP 800-108 allows defining a different order than proposed by the standard as long as it is unambiguously defined.

- A 2-byte label, distinguishing the purpose of the key: 0x3CC3 for MACing and 0xC33C for encryption.
- A 2-byte counter
  - KeyType.AES128: fixed to 0x0001.
  - KeyType.AES256: counting from 0x0001 to 0x0002.
- A 2-byte length,
  - KeyType.AES128: fixed to 0x0080.
  - KeyType.AES256: fixed to 0x0100.
- A context, constructed using the UID and/or SDMReadCtr, followed by zero-byte padding if needed.

Whether or not the UID and/or SDMReadCtr are included in session vector SV2, depends on whether they are mirrored, see [Section 6.4.8.3](#). In case of encrypting file data, mirroring of both is mandatory.

Therefore, they are always included in SVx.

##### KeyType.AES128

First, the input session vectors SVx are derived as follows:

$$SV1 = 0xC3 \parallel 0x3C \parallel 0x00 \parallel 0x01 \parallel 0x00 \parallel 0x80 \parallel UID \parallel SDMReadCtr$$

$$SV2 = 0x3C \parallel 0xC3 \parallel 0x00 \parallel 0x01 \parallel 0x00 \parallel 0x80 [ \parallel UID ] [ \parallel SDMReadCtr ] [ \parallel ZeroPadding ]$$

Padding with zeros is done up to a multiple of 16 bytes. So, in case of 7-byte UID and both elements are mirrored, no padding is added. Then, the 16-byte session keys are constructed as follows:

$$\text{SesSDMFileReadENCKey} = \text{MAC}(\text{SDMFileReadKey}; SV1)$$

$$\text{SesSDMFileReadMACKey} = \text{MAC}(\text{SDMFileReadKey}; SV2)$$

**KeyType.AES256**

First, the input session vectors SV<sub>xy</sub> are derived as follows:

$$SV\ 1a = 0xC3||0x3C||0x00||0x01||0x01||0x00||V\ CUID||SDMReadCtr||ZeroPadding]$$

$$SV\ 1b = 0xC3||0x3C||0x00||0x02||0x01||0x00||V\ CUID||SDMReadCtr||ZeroPadding]$$

$$SV\ 2a = 0x3C||0xC3||0x00||0x01||0x01||0x00||V\ CUID||SDMReadCtr||ZeroPadding]$$

$$SV\ 2b = 0x3C||0xC3||0x00||0x02||0x01||0x00||V\ CUID||SDMReadCtr||ZeroPadding]$$

Padding with zeros is done up to a multiple of 16 bytes. So in the case of 7-byte UID and both elements are mirrored, no padding is added. Then, the 32-byte session keys are constructed as follows:

$$SesSDMFileReadENCKey = MAC(SDMFileReadKey; SV1a) || MAC(SDMFileReadKey; SV1b)$$

$$SesSDMFileReadMACKey = MAC(SDMFileReadKey; SV2a) || MAC(SDMFileReadKey; SV2b)$$

**6.4.8.13 Output Mapping Examples**

The following figure shows an example with the static file content and how it will be read.

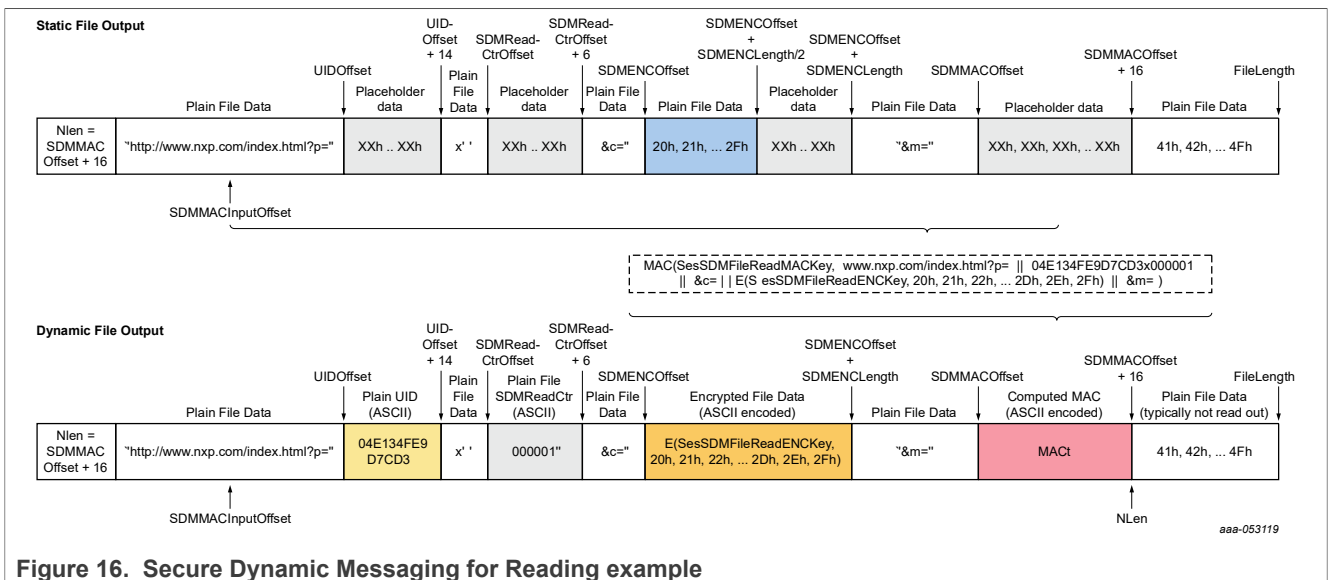

**6.5 Access Rights Management**

NTAG X DNA manages its access rights through access conditions. This is explained in [Section 6.5.1](#). How access rights can be granted through certificates presented during asymmetric authentication is explained in [Section 6.5.3](#).

**6.5.1 Access conditions**

For file access, the conditions for the file access rights are associated with the file, as explained in [Section 6.11.2](#). For other commands, the access conditions are either fixed or configurable via other means.

Nevertheless, the interpretation of access conditions and their representation in the command API is always the same. There are three kinds of access conditions:

- The *authentication* access conditions where a valid authentication is required. The access condition is satisfied by one of the following means:
  - an active symmetric authentication with the [AuthKey](#) addressed by the key number encoded by the access condition.
  - an active asymmetric authentication granting the access condition via the current [CertAccessRights](#). This means the [CARootKey](#) addressed during the authentication must have been associated with access rights encoded by the access condition. How a [CARootKey](#) is configured with its access rights is defined in [Section 6.5.2](#). Optionally the reader certificate (or certificate chain) presented during the authentication can further restrict the granted access rights from the [CARootKey](#). This is specified in [Section 6.5.3](#).
- The *free access over NFC* condition meaning the related commands can be accessed without an active authentication over the NFC interface.
- The *free access over I<sup>2</sup>C* condition meaning the related commands can be accessed without an active authentication over the I<sup>2</sup>C interface.
- The *free access condition* meaning the related commands can be accessed without an active authentication over any interface.
- The *no access condition* meaning no access to the related commands.

**Note:** In other parts of the document, when it is stated that an active authentication with [AppKey](#) is required, this means either a symmetric authentication with that particular key, or an asymmetric authentication granting equivalent access rights (even if the latter is not explicitly mentioned).

The access conditions are specified on 4 bits as defined in [Table 18](#).

Table 18. Access condition values coded on 4 bits

Condition value	Description
0x0..0xB	authentication required
0xC	free access over NFC, authentication required over I <sup>2</sup> C
0xD	free access over I <sup>2</sup> C, authentication required over NFC
0xE	free access
0xF	no access or RFU

A 0xC or 0xD access condition can also still be obtained over the respectively I<sup>2</sup>C, or NFC interface, if obtaining the access right from an ECC-based authentication.

The *free access over NFC* enables use cases like storing a Matter PASE passcode, see [\[23\]](#).

Concretely, this means that the access conditions 0x0..0x4 can be obtained both through symmetric and asymmetric authentication, while the access conditions 0x5..0xD can be obtained through asymmetric authentication independently of the interface.

This is also illustrated by [Figure 17](#) where access condition 0x0 can be obtained via a symmetric authentication targeting [AppKey](#) 0x00, i.e. the [AppMasterKey](#), but also through an asymmetric authentication targeting [CARootKey](#).1, with an AMap set to 0x0021. This means that the latter also grants [AppMasterKey](#) access rights.

In the case of asymmetric authentication, the access rights granted depend on the targeted [CARootKey](#), but can be further restricted via the certificate. If a certificate does not hold explicit access rights, the access rights from the related [CARootKey](#) are implicitly inherited and therefore granted. When authenticating [CARootKey](#).1 of the example below, by default the accumulated access rights equivalent to being authenticated with either symmetric key 0x0 or key 0x5 will be granted. However, Cert.ReaderB handed out by the CA related with [CARootKey](#).1, only grants access right 0x5, and therefore in that case not the [AppMasterKey](#) access rights. [CARootKey](#).1 only has two bits set, but there is no limitation on the number of bits and therefore access rights

that can be granted to a [CARootKey](#): it could have all 14 bits set, granting access rights equivalent to the symmetric key 0x0 until 0xD.

Another example: If successfully authenticated with Cert.ReaderC, the user is granted access right 0x6 associated with the [CARootKey.2](#), having its ACMap set to 0x0040. A CA shall not hand out certificates with access rights that exceed the access rights associated with the [CARootKey](#). For example, a certificate with access right 0x3 handed out by the CA associated with [CARootKey.1](#) will not be accepted by NTAG X DNA as this access right is not configured for [CARootKey.1](#).

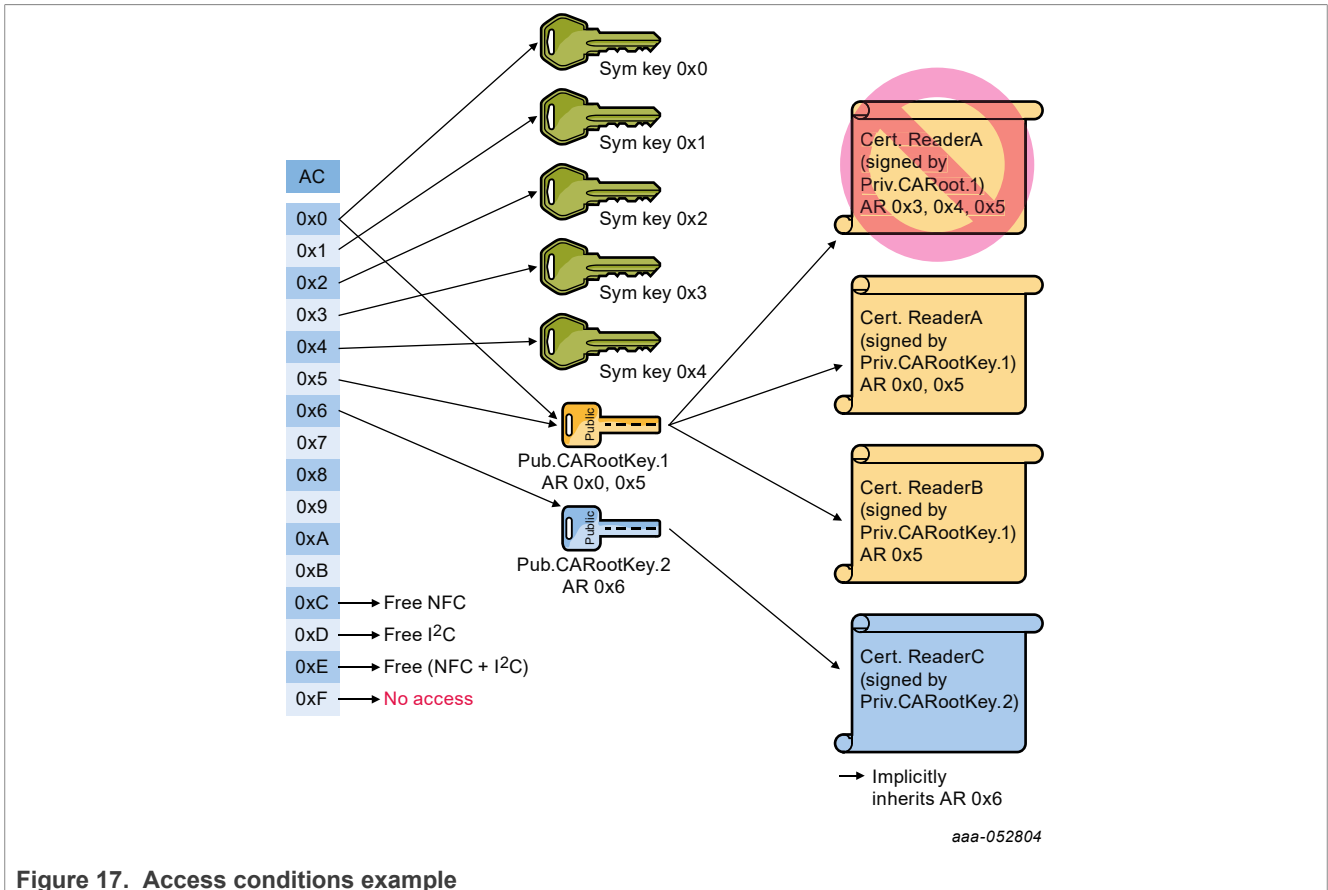

Figure 17. Access conditions example

### 6.5.2 CARootKey access rights

Access rights are associated with a [CARootKey](#) through [ManageCARootKey](#). For this command, the access conditions that can be granted when authenticated with this [CARootKey](#) are encoded on a bitmap, as defined in [Table 19](#). As defined in [Section 6.17.1.1](#), this bitmap is sent on the interface LSB first.

Table 19. ACMap encoding

BitIndex	Description
Bit 15-14	RFU
Bit 13-0	AC bitmap. If bit 0 is set, AC 0x0 access rights are granted. If bit 1 is set, AC 0x1 access rights are granted. And so on.

For these access rights the whole range of the AC bitmap can be used, independently of whether those bits encode key numbers of keys that exist in the targeted application. For example, if the application holds five symmetric keys, the key numbers 0x0-0x4 (i.e. bit 0 until bit 4 in the certificate encoding) can be used to specify access conditions that can be obtained by both symmetric and asymmetric authentication. From bit 5 onwards,

the bits can only be used to specify access conditions that can be obtained via an asymmetric authentication, as there does not exist an equivalent symmetric key within the application.

Access rights obtained during a mutual authentication can be further restricted via the presented certificates, as defined in [Section 6.5.3](#). There the same encoding is used.

**6.5.3 Certificate access rights**

NTAG X DNA supports a private extension (ARExtension) for access right encoding within X.509 certificates. This extension is reflected by an OID in the NXP range: 1.3.6.1.4.1.28137.64.1. If not present, the CertAccessRights are inherited from the parent certificate, or in the case of no parent, the targeted [CARootKey](#).

This access right extension will be processed independently of whether the criticality flag is set or not. NTAG X DNA does not recognize any other extension. If a reader certificate with another extension marked critical is presented, it is rejected. If the criticality flag of an unrecognized extension is not set, the extension is ignored without rejecting the certificate.

This ARExtension has the following ASN.1 encoding:

```
ARExtension - SEQUENCE {
    arExtnId OBJECT IDENTIFIER (id-nxp-ar),
    critical BOOLEAN (TRUE),
    arExtnValue OCTET STRING
}
```

CertAccessRights are obtained from a successful SIGMA-I authentication, see [Section 6.4.2](#). They are maintained as long as in [VCState.AuthenticatedECC](#).

The access right extension value (ARExtensionValue) shall hold the data structure as defined in [Table 20](#). The actual length and value format depend on the ARTYPE. The total length is also encoded in the OCTET STRING encoding of the extension.

**Table 20. Application access rights, specified via DFName**

Field	Length/Bit Index	Description
ARTYPE	1	Tag specifying the type of ARG
	Bit 7	CA delegation
		'0': disabled (leaf)
		'1': enabled (parent or leaf)
	Bit 6-0	AR Type
		0x02: Application access rights, specified via DFName
ARValue	Variable	Actual access rights

Bit 7 of the ARTYPE indicates whether the certificate can be used as a parent certificate delegating access rights. Only if the bit is set, the certificate can be used to compose a certificate chain, representing an intermediate CA. In this case the certificate can also still be used directly as a leaf certificate. If the bit is not set, the certificate can only be used as a leaf certificate. If used as a parent with the bit not set, the certificate validation fails.

In the case of application access rights, specified via DFName, as defined in [Table 21](#), the ARValue consist of a variable length DFName, followed by a 2-byte ACMap. The latter defines the actual access rights granted for that application, as further defined in [Table 19](#).

Table 21. Application access rights, specified via DFName

Field	Length	Value	Description
ARType	1	0x02/0x82	Access rights for application with the given DFName
DFNameLen	1	0x01.. 0x10	Length of the subsequent DFName of the application. This shall be set to 0x07 for NTAG X DNA.
DFName	DFNameLen	Full Range	DF Name of the application
ACMap	2	see <a href="#">Table 19</a>	2-byte map of granted access conditions of the application

## 6.6 Card Memory and Configuration Management

### 6.6.1 Card UID

NTAG X DNA's unique identifier (UID) is a 7 or 10 byte serial number defined as UID in ISO/IEC 14443-3. This UID is generated by the manufacturer of the card and programmed into a locked part of the NV-memory. The programmed UID is not changeable.

The 1st byte of the UID, *UID0*, as defined in ISO/IEC 7816-6 AMD 1 holds the manufacturer ID that is 0x04 for NXP Semiconductors.

The remaining bytes of UID, i.e. *UID1- UID6* for double size or 7-byte UID are chosen by the manufacturer to be unique.

#### 6.6.1.1 Random ID

NTAG X DNA can be configured with [SetConfiguration](#) to use a Random ID for the anticollision procedure as specified in ISO/IEC 14443-3. The Random ID is defined on 4 bytes as a single size UID defined in ISO/IEC 14443-3 [4]. *UID0* is defined as 0x08 and *UID1 - UID3* are randoms.

#### 6.6.1.2 Command [GetCardUID](#)

Reading the UID of a card as defined in [Section 6.6.1](#) is possible with the command [GetCardUID](#) as defined in [Section 7.4.6](#).

No parameters are passed with this command.

Even if the Random ID feature is activated, [GetCardUID](#) returns the real UID of the card. [GetCardUID](#) is allowed only if a previous successful authentication has been done with any key allowing authentications present on the card. This can be further restricted to a single [AppKey](#) by configuring an [AppPrivacyKey](#) for enhanced privacy with [SetConfiguration](#) Option 0x0E.

The communication mode is always [CommMode.Full](#). Information on the authentication and secure messaging-dependent structure of the command can be found in [Section 6.4](#).

### 6.6.2 Card Version

NTAG X DNA is characterized by manufacturer-related data. These data are composed from HW-related information, SW-related information and production-related information as detailed in [Table 22](#). For concrete response values, see [Table 95](#).

Table 22. Manufacturer characteristics used as card version

Manufacturer characteristics	Size in bytes	Details
<i>Hardware-related information</i>		
Vendor ID	1	Identification of the card vendor, 0x04 for NXP Semiconductors.
HW type	1	Hardware platform type.
HW subtype	1	Hardware platform subtype.
HW major version number	1	Hardware platform major version number.
HW minor version number	1	Hardware platform minor version number.
HW storage size	1	Hardware platform storage size. See <a href="#">Table 95</a> for actual values.
HW protocol	1	Hardware communication protocol type.
<i>Software-related information</i>		
Vendor ID	1	Card vendor identification.
SW type	1	Card software type.
SW subtype	1	Card software subtype.
SW major version	1	Card Software major version number: reflects the evolution(EVx) and is only incremented on major feature introduction.
SW minor version	1	Card Software minor version number: consists of SW minor (upper nibble) and sub-minor (lower nibble) version. SW minor version will be incremented if introducing new features or feature extensions not justifying an SW major increment. SW sub minor will be incremented on patched versions or very minor feature extensions.
SW storage size	1	Card Software storage size. See <a href="#">Table 99</a> for actual values.
SW protocol	1	Card Software communication protocol type.
<i>Production-related information</i>		
<a href="#">UID</a>	7	Card unique identifier as defined in <a href="#">Section 6.6.1</a> . If the Random ID is activated always 7 0x00 bytes are returned. When switching to random ID this is only reflected after reset and reactivation.
Batch number	3	Fabkey server batch number.
FabKeyID	2	Fabkey identifier in alphanumeric ASCII encoding
CW production	1	Calendar week of card production in BCD coding (i.e. week36 is code as 0x36).
Year of production	1	Year of card production in BCD coding (i.e. year 2012 is code as 0x12).
Fab ID	[1]	Fab Identifier, only present if requested via Option byte.

For enhanced privacy, NTAG X DNA supports an option to mask the manufacturer data, i.e. Batch Number, CW production, Year of production and FabKey (as a consequence FabKeyID will not be present). This masking of manufacturer data can be configured with [SetConfiguration](#) Option 0x0E, see [Section 6.6.2](#). If enabled, this is independent of the Random ID configuration, and of whether there is an active authentication.

6.6.2.1 Command [GetVersion](#)

Reading the version of a card as defined in [Section 6.6.2](#) is possible with the command [GetVersion](#) as defined in [Section 7.4.5](#).

No parameters are passed with this command.

The version data is return over three frames. As specified in [Table 22](#), 1st Frame returns the hardware-related information, 2<sup>nd</sup> returns the software-related information, and the 3<sup>rd</sup> and last frame returns the production-related information.

This command does not require authentication. If there is an active authentication, the command [GetVersion](#) requires [CommMode.MAC](#). Information on the authentication and secure messaging-dependent structure of the command can be found in [Section 6.4](#).

6.6.3 Card configuration

6.6.3.1 Deferred Configuration Options

Certain product manufacturers may not be able to cope with the advanced options of NTAG X DNA in their personalization reader infrastructure. For example, these readers do not implement authentication and secure messaging, or are not able to cope with random ID during the ISO/IEC 14443-4 activation. Therefore, they hand out the initial personalization to a different party, e.g. a label manufacturer. This label manufacturer inserts the required keys, personalizes the files and does the required product configurations. When handed over to the actual product manufacturer, this party might still want to read-out the actual UID for its inventory management.

Therefore, NTAG X DNA allows to defer the configuration of:

- Random ID, see [SetConfiguration](#) Option 0x00. Deferring RandomID means that also the related ATQA/SAK processing and [GetVersion](#) masking will be deferred.
- Silent Mode, see [SetConfiguration](#) Option 0x0D.
- TagTamper, i.e. deferring the boot measurements, see [Section 6.15](#) and [SetConfiguration](#) Option 0x11. Only the Tag Tamper boot measurements are deferred, i.e. other GPIO configurations are not affected, and read commands can still trigger a Tag Tamper measurement.
- SDM encryption of [PICCData](#) (UID, SDMCounter) and [SDMENCFileData](#), see [Section 6.4.8](#) and [Section 6.11.2.3](#). Plain [PICCData](#) shall consist of the plain [PICCDataTag](#), [UID](#), [SDMReadCtr](#) and Random-Padding, depending on the SDM configuration, i.e. fields are mirrored as configured without just applying encryption. Plain [SDMENCFileData](#) is just returning the plain static file data as is, mirroring [GPIOStatus](#) also in plain if applicable.

The [SetConfiguration](#) options of the above list are deferred via [SetConfiguration](#) Option 0xFE, see [Section 6.6.3.1](#) and [Table 24](#). Each deferral item is defined by the option and method, see [Table 23](#). If a previously deferred option is reconfigured to [DeferMethod](#) 0x00, the deferral is abolished. Any nonlisted option is not affected by the configuration.

Table 23. DeferralItem

Field	Length/ BitIndex	Description
DeferOption	1	Deferred Option
	0x00	PICCRandom ID Configuration
	0x0D	SilentMode Configuration
	0x11	GPIO Configuration, i.e. TagTamper boot measurement.
	Other	RFU
DeferMethod	1	Deferral Method

Table 23. DeferralItem...continued

Field	Length/ BitIndex	Description
	0x00	No deferral (default value)
	0x01 .. 0x07	Number of boots (i.e. first ISO/IEC 14443-4 command)
	0xFF	<a href="#">ActivateConfiguration</a>
	Other	RFU

The SDM encryption can be deferred via [ChangeFileSettings](#), see [Section 6.11.2.3](#). There are two ways how a deferred configuration can be abolished:

- after having executed a predefined amount of boots. Note that the number of boots is counted on the first command after ISO/IEC 14443-4 activation. If ISO/IEC 14443-4 DESELECT is the first command sent after the activation, this boot is not counted.
- after having executed a specific command, i.e. [ActivateConfiguration](#). This command does not require any authentication.

For each of the deferred configuration options, the method to end the deferring can be separately configured. However, for counting the amount of boots, NTAG X DNA will maintain a single BootCtr. This BootCtr is reset to zero each time a configuration is configured for deferral via amount of boots, be it with [SetConfiguration](#) Option 0xFE or [ChangeFileSettings](#). If a configuration is deferred via the number of boots, the deferral will be applied and boots will already be counted, independently if the actual configuration has already been applied before or still must be applied after the deferral configuration.

6.6.3.1.1 Command ActivateConfiguration

Depending on the configuration, see above, [ActivateConfiguration](#) can be used to abolish a deferred configuration. [ActivateConfiguration](#) provides the list of deferred configurations for which the deferral can be ended. The command will be rejected in case the deferred configuration shall not be activated via this command (i.e. if configured to be activated through a number of boots) or if it was already activated or never deferred.

The [ActivateConfiguration](#) can be issued both at PICC and application level, and does not require an authentication. If authenticated, the command shall be sent with [CommMode.MAC](#).

6.6.3.2 Command SetConfiguration

[SetConfiguration](#) is updating configuration settings. Its specifications can be found in [Section 7.4.2](#). The command consists of an option byte and a data field with a size depending on the option.

In the below table, “No change” references are used with configurations that are persistent. This means that the associated configuration is left as it is already in the card and its value is not changed.

Table 24. [SetConfiguration](#) options list

Option byte	Field	Length/ BitIndex	Description
0x00		<b>Total: 1</b>	<b>PICC Configurations</b>
	PICCConfig	1	
		Bit 7-2	RFU
		Bit 1	UseRID (disabled by default) 0: No change 1: Enable ISO random ID (UID0 = 0x08). Definitive configuration, can not change it anymore thereafter.

Table 24. [SetConfiguration](#) options list...continued

		Bit 0	RFU
0x01			Reserved
0x02		<b>Total: 1..20</b>	<b>ATSUpdate</b>
	UserATS	1..20	User-defined ATS. TL byte of the ATS should be as $0 < TL \leq 20$ . FSCI 4-bits value part of T0 format byte (see ISO/IEC14443-4) should be supported by the card. Default values of ATS are given in <a href="#">Section 6.1.1</a> . Refer to ISO/IEC 14443-4 for ATS definition.
0x03		<b>Total: 2</b>	<b>SAKUpdate</b>
	UserSAK	2	User-defined SAK1 and SAK2 each of one byte long formatted as SAK1 ISAK2. Default values of SAK1 and SAK2 are given in <a href="#">Section 6.1.1</a> . Refer to ISO/IEC14443-3 for SAK1 and SAK2 definition.
0x04		<b>Total: 2</b>	<b>SecureMessaging Configuration</b>
	SMConfigA	1	Secure messaging configuration (Byte A)
		Bit 7-3	RFU
		Bit 2	EV2 secure messaging configuration for <a href="#">FileType.StandardData</a>
			0: No change 1: In <a href="#">VCState.AuthenticatedAES</a> and <a href="#">VCState.AuthenticatedECC</a> , disable chained writing with <a href="#">WriteData</a> in <a href="#">CommMode.MAC</a> and <a href="#">CommMode.Full</a> .
		Bit1-0	Reserved
	SMConfigB	1	RFU
Bit 7-0		RFU	
0x05		<b>Total: 10</b>	<b>CapabilityData</b> Capability data, consisting of PDCap2.
	RFU	8	RFU
	PDCap2.5	1	User configured PDCap2.5
	PDCap2.6	1	User configured PDCap2.6
0x06 .. 0x0B			Reserved
0x0C		<b>Total: 2</b>	<b>ATQA Update</b>
	UserATQA	2	User-defined ATQA, encoded LSB first as transmitted during ISO/IEC 14443 activation. Default values of ATQA are given in <a href="#">Section 6.1.1</a> . Refer to ISO/IEC 14443-3 for ATQA definition.
0x0D		<b>Total: 1, 3</b>	<b>Silent Mode Configuration</b>
	SilentMode	1	Silent mode options
		Bit 7-2	RFU
		Bit 1	Customized REQS/WUPS enabling
			0: CustomizedREQS/WUPS disabled (default)
			1: Customized REQS/WUPS enabled
		Bit 0	Silent mode enabling
0: Silent mode disabled (default)			

Table 24. [SetConfiguration](#) options list...continued

			1: Silent mode enabled
	REQS	[1]	[Optional,present if customized REQS/WUPS enabled] CustomREQS
	WUPS	[1]	[Optional,present if customized REQS/WUPS enabled] CustomWUPS
<b>0x0E</b>		<b>Total: 2</b>	<b>Enhanced Privacy Configuration</b>
	PrivacyOption	1	Enable/Disable privacy features
		Bit 7-3	RFU
		Bit 2	Originality Check disabling
			0: Originality Check enabled (default)
			1: Originality Check disabled
		Bit 1	Manufacturer data masking
			0: Manufacturer data masking disabled (default)
			1: Manufacturer data masking enabled
	Bit 0	<a href="#">AppPrivacyKey</a> enabling	
		0: <a href="#">AppPrivacyKey</a> disabled (default)	
		1: <a href="#">AppPrivacyKey</a> enabled	
	AppPrivacyKey	1	<a href="#">AppPrivacyKey</a> definition
			0x00: if <a href="#">AppPrivacyKey</a> disabled
			0x00 .. 0x0B: <a href="#">AppPrivacyKey</a> if <a href="#">AppPrivacyKey</a> enabled
			0x0C.. 0xFF: RFU if <a href="#">AppPrivacyKey</a> enabled
<b>0x0F</b>		<b>Total: 3</b>	<b>NFC Management</b>
	NFCSupport	1	NFC Support
		Bit 7-1	RFU
		Bit 0	NFC I/O
			0: NFC disabled
		1: NFC enabled (default)	
	ProtocolOptions	2	The crypto protocols supported over NFC. See <a href="#">Table 25</a> . The default value is that all protocols supported in the manufacturing features selection map are enabled and Protocol Negotiations disabled.
<b>0x10</b>		<b>Total: 4</b>	<b>I2C Management</b>
	I2CSupport	1	I2C Support
		Bit 7-1	RFU
		Bit 0	I2C I/O
			0: I2C disabled
		1: I2C enabled (default)	
	I2CAddress	1	The address used for the I2C target (default 0x20)

Table 24. [SetConfiguration](#) options list...continued

	ProtocolOptions	2	The crypto protocols supported over I2C. See <a href="#">Table 25</a> . The default value is that all protocols supported in the manufacturing features selection map are enabled and Protocol Negotiations disabled.
<b>0x11</b>		<b>Total: 28</b>	<b>GPIO Management</b>
	GPIO1Mode	1	GPIO1 Mode
			0x00: disabled (default)
			0x01: input
			0x02: output
			0x03: input tag tamper
			0x04: down-stream power out
	GPIO1Config	1	GPIO1 Configuration, see <a href="#">Table 26</a> .
	GPIO1PadCtrl	4	GPIO1 Pad Control, see <a href="#">Table 27</a> .
	GPIO2Mode	1	GPIO2 Configuration
			0x00: disabled (default)
			0x01: input
			0x02: output
			0x05: output with NFCPause file
	GPIO2Config	1	GPIO2 Configuration, see <a href="#">Table 26</a> .
	GPIO2PadCtrl	4	GPIO2 Pad Control, see <a href="#">Table 27</a> .
	GPIO1Notif	1	GPIO notification on authentication. Note: notification shall only be allowed if GPIO1Mode is 0x02.
			0x00: disabled (default)
			0x01: enable authentication notification
			0x02: enable NFC field notification
GPIO2Notif	1	GPIO notification on authentication. Note: notification shall only be allowed if GPIO2Mode is 0x02.	
		0x00: disabled (default)	
		0x01: enable authentication notification	
		0x02: enable NFC field notification	
ManageGPIO-AccessCondition	1	<a href="#">ManageGPIO</a> access condition	
	Bit 7-6	RFU	
	Bit 5-4	CommMode, see <a href="#">Table 15</a> .	
	Bit 3-0	AccessCondition Value, see <a href="#">Table 18</a> . Default 0xF.	
ReadGPIO-AccessCondition	1	<a href="#">ReadGPIO</a> access condition	
	Bit 7-6	RFU	
	Bit 5-4	CommMode, see <a href="#">Table 15</a> .	
	Bit 3-0	AccessCondition Value, see <a href="#">Table 18</a> . Default 0xF.	
DefaultTarget	1	[Applicable when GPIO1Mode = 0x04] Targeted voltage/current level	
		0x00: disable in rush current limit.	

Table 24. [SetConfiguration](#) options list...continued

			0x01: power downstream of 1.8 V and 100 µA
			0x02: power downstream of 1.8 V and 300 µA
			0x03: power downstream of 1.8 V and 500 µA
			0x04: power downstream of 1.8 V and 1 mA
			0x05: power downstream of 1.8 V and 2 mA
			0x06: power downstream of 1.8 V and 3 mA
			0x07: power downstream of 1.8 V and 5 mA
			0x08: power downstream of 1.8 V and 7 mA
			0x09: power downstream of 1.8 V and 10 mA
			0x11: power downstream of 2 V and 100 µA
			0x12: power downstream of 2 V and 300 µA
			0x13: power downstream of 2 V and 500 µA
			0x14: power downstream of 2 V and 1 mA
			0x15: power downstream of 2 V and 2 mA
			0x16: power downstream of 2 V and 3 mA
			0x17: power downstream of 2 V and 5 mA
			0x18: power downstream of 2 V and 7 mA
			0x19: power downstream of 2 V and 10 mA
			0x1F: power downstream of 2 V and MAX available current
	InRushTarget	1	[Applicable when GPIO1Mode = 0x04] Initial current limit to handle the in rush of current when charging an external capacitor.
			0x00: disable in rush current limit.
			0x01: power downstream of 1.8 V and 100 µA
			0x02: power downstream of 1.8 V and 300 µA
			0x03: power downstream of 1.8 V and 500 µA
			0x04: power downstream of 1.8 V and 1 mA
			0x05: power downstream of 1.8 V and 2 mA
			0x06: power downstream of 1.8 V and 3 mA
			0x07: power downstream of 1.8 V and 5 mA
			0x08: power downstream of 1.8 V and 7 mA
			0x09: power downstream of 1.8 V and 10 mA
			0x11: power downstream of 2 V and 100 µA
			0x12: power downstream of 2 V and 300 µA
			0x13: power downstream of 2 V and 500 µA
			0x14: power downstream of 2 V and 1 mA
			0x15: power downstream of 2 V and 2 mA
			0x16: power downstream of 2 V and 3 mA
			0x17: power downstream of 2 V and 5 mA

Table 24. [SetConfiguration](#) options list...continued

			0x18: power downstream of 2 V and 7 mA
			0x19: power downstream of 2 V and 10 mA
			0x1F: power downstream of 2V and MAX available current
InRushDuration	2		[Applicable when GPIO1Mode = 0x04] The duration to apply the InRushTarget
			0x0000.. 0xFFFF: targeted duration in ms.
AdditionalCurrent	1		[Applicable when GPIO1Mode = 0x04] The additional current required by NTAG X DNA when supplying power harvesting.
			Resolution: 0.4 mA.
			0x00..0x1F
NFCPauseFileNo	1		[Applicable when GPIO2Mode = 0x05] FileNo of the <a href="#">FileType.StandardData</a> file for NFCPause
			0x00.. 0x1F: targeted FileNo
NFCPauseOffset	3		[Applicable when GPIO2Mode = 0x05] Starting offset of the section within the targeted file triggering NFCPause
			0x000000.. 0xFFFFFFFF: targeted offset
NFCPauseLength	3		[Applicable when GPIO2Mode = 0x05] Length of the section within the targeted file starting at NFCPauseOffset triggering NFCPause
			0x000000.. 0xFFFFFFFF: targeted length
<b>0x12</b>		<b>Total: 2</b>	<b>ECCKey Management</b>
ManageKeyPair AccessCondition	1		<a href="#">ManageKeyPair</a> access condition
	Bit 7-6		RFU
	Bit 5-4		CommMode, see <a href="#">Table 15</a> . Default '11'.
	Bit 3-0		AccessCondition Value, see <a href="#">Table 18</a> . Default 0x0.
ManageCARoot KeyAccess Condition	1		<a href="#">ManageCARootKey</a> access condition
	Bit 7-6		RFU
	Bit 5-4		CommMode, see <a href="#">Table 15</a> . Default '11'.
	Bit 3-0		AccessCondition Value, see <a href="#">Table 18</a> . Default 0x0.
<b>0x13</b>		<b>Total: 4</b>	<b>CertificateManagement</b> , see <a href="#">Section 6.9</a>
LeafCacheSize	1		End Leaf certificate cache size: number of slots in end leaf cert cache. The certificate cache is created the first time that it is enabled or on the first boot if enabled by default. The cache sizes are ignored after the certificate cache has been created.
			0x01..0x08
IntermCacheSize	1		Intermediate certificate cache size: number of slots in end leaf cert cache. The certificate cache is created the first time that it is enabled or on the first boot if enabled by default. The cache sizes are ignored after the certificate cache has been created.
			0x02..0x08
FeatureSelection	1		Feature Selection
	Bit 7-5		RFU
	Bit 4-3		HostCertificate Support

Table 24. [SetConfiguration](#) options list...continued

			01: support full host certificates Other: RFU	
		Bit 2-1	RFU 00: repository default (use certs as stored in the certificate repo)	
		Bit 0	EnableSIGMA-I cache 0: disabled (default) 1: enabled	
			ManageCert Repo- Access Condition	1 ManageCertRepoCreate Option ('00') Access Condition
	ManageCert Repo- Access Condition	Bit 7-6	RFU	
		Bit 5-4	CommMode, see <a href="#">Table 15</a> . Default '01'.	
		Bit 3-0	AccessCondition Value, see <a href="#">Table 18</a> . Default 0x0. The read and write/reset certificate repository access conditions are set during repository creation.	
	<b>0x14</b>		<b>Total: 3</b> <b>WatchdogTimer Management</b> , see <a href="#">Section 6.16</a>	
	HWDTValue	1	HaltWatchdog Timer (HWDT) Value. Maximum time before NTAG X DNA shall enter the hardware HALT state. The timer is started by device reset or when the device exits the Halt state. It is reset by command reception on NFC or I2C. 0x00: disabled (default) 0x01..0x3C: 1-60 seconds	
			AWDT1Value	1
AWDT2Value				
	<b>0x15</b>		<b>Total: 5+M*3+N*3</b> <b>CryptoAPI Management</b>	
Support	1	CryptoAPI Support		
		Bit 7-2	RFU	
		Bit 1	AsymmetricCrypto API '0': disabled '1': enabled (default)	
	Bit 0		SymmetricCrypto API '0': disabled '1': enabled (default)	
		AccessCondition	1	Access condition for <a href="#">CryptoRequest</a>

Table 24. [SetConfiguration](#) options list...continued

		Bit 7-6	RFU	
		Bit 5-4	CommMode, see <a href="#">Table 15</a> . Default <a href="#">CommMode.MAC</a> .	
		Bit 3-0	AccessCondition Value, see <a href="#">Table 18</a> . Default 0x0.	
ChangeAC	1		Access condition for <a href="#">ChangeKey</a> targeting <a href="#">CryptoRequestKey</a> .	
		Bit 7-4	RFU	
		Bit 3-0	AccessCondition Value, see <a href="#">Table 18</a> . Default 0x0.	
TBPolicyCount	1		CryptoAPI Transient Buffer Policy Count (M) 0x00..0x08	
TBPolicy	M*3		Crypto API Transient Buffer Policy, see <a href="#">Section 6.13</a> . Each 3-byte instance consists of: Destination (see <a href="#">Table 40</a> )    Usage Policy (see <a href="#">Table 41</a> )    Algorithm Policy (see <a href="#">Table 42</a> )	
SBPolicyCount	1		CryptoAPI Static Buffer Policy Count (N) 0x00..0x0E	
SBPolicy	N*3		CryptoAPI Static Buffer Policy, see <a href="#">Section 6.13</a> . Each 3-byte instance consists of: Destination (see <a href="#">Table 40</a> )    Usage Policy (see <a href="#">Table 41</a> )    Algorithm Policy (see <a href="#">Table 42</a> )	
0x16		<b>Total: 6</b>	<b>AuthenticationCounter and Limit Configuration</b>	
	AuthCtrFileID	1	Targeted <a href="#">FileType.Counter</a> 0x00..0x1F: FileID of the targeted file	
	AuthCtrOption	1	Authentication counter options	
			Bit 7-1	RFU
			Bit 0	<a href="#">AuthenticateEV2First</a> (AES-based authentication) '0': disabled (default) '1': enabled
	AuthCtrLimit	4	Authentication Counter Limit	
			0x00000000: <a href="#">AuthCtrLimit</a> disabled 0x00000001.. 0xFFFFFFFF: <a href="#">AuthCtrLimit</a> enabled with the given value	
0x17		<b>Total: 4</b>	<b>HALTandWake-upConfiguration</b>	
	WakeUpA	1	Wake-up options (Byte A)	
		Bit 7	RFU	
		Bit 6	GPIOwake-up: GPIO2 pulldown triggers wake-up. '0': disabled (default) '1': enabled	
			Bit 5-0	I2C wake-up address (default: 0x20): 6 MSB of 7-bi I2C address used for wake-up Full range
	WakeUpB	1	Wake-up options (Byte B)	

Table 24. [SetConfiguration](#) options list...continued

		Bit 7	I2C wake-up address (default: 0x20): LSB of 7-bit I2C wake-up Address Full range	
		Bit 6-3	I2CSDA wake-up cycles (default: 0x0): number of SCL cycles that are required to wake up when SDA is pulled down. Full range	
		Bit 2	I2C address wake-up: If targeted I2C address matches the configured I2C wake-up address, wake-up is triggered. '0': disabled '1': enabled (default)	
		Bit 1	I2C SDA cycle wake-up: If I2C SDA cycles match the configured I2C wake-up cycles, wake-up are triggered. '0': disabled (default) '1': enabled	
		Bit 0	NFCfield: wake up from HALT state in presence of NFC field. '0': disabled '1': enabled (default)	
		RDACSetting	1	RDACSetting: impacts how much energy is drawn from the RF field, while the device is in HALT state. 0x00..0xFF (default: 0x00)
		HALTOption	1	HALT options
			Bit 7-2	RFU
			Bit 1	GPIO2 reset: before entering power-saving HALT state, GPIO2 pin resets to High-Z state. '0': disabled '1': enabled (default)
			Bit 0	GPIO1 reset: before entering a power-saving HALT state, GPIO1 pin resets to High-Z state. '0': disabled '1': enabled (default)
				RFU
		0x18 .. 0xFD		
0xFE		<b>Total: 1+N*2</b>	<b>Defer Configurations</b>	
	DeferralCount	1	DeferralCount (N) 0x01..0x03	
	DeferralList	N*2	List of Deferrals. See <a href="#">Table 23</a> .	
0xFF		<b>Total: 3</b>	<b>Lock Configurations</b>	
	LockMap	3	Bitmap where each bit encodes for the related configuration option if it is locked. LSB first, i.e. first byte encodes Option 0x07-0x00.	

Table 24. [SetConfiguration](#) options list...continued

		Bit 23-0	Lock bit
			'0': No Change
			'1': Lock configuration

Application Remark:

The InRush Target current shall always be set to the same level as the minimum configured power downstream current. The InRush current and it's ramp time determine the system's settling time for buffer cap charging and initial ramp up of the IC external components. Therefore an InRushTarget configuration of 0x00 is causing system instabilities and shall be avoided.

The InRushTarget current and InRush Duration shall be chosen according minimum current needs of external components and the buffer cap size.

To configure the power downstream output current to maximum available current, that can be derived from the RF field, DefaultTarget shall be configured to 0x0F or 0x1F, for other configurations exceeding the maximum available current an error will be reported.

Changes of the output voltage level by changing DefaultTarget during already enabled power downstream does not have any impact, the initially configured output voltage is not changed.

The actual power downstream output current and output voltage provided at GPIO1 depends, besides DefaultTarget configuration, on the RF field strength and varies based on RF field changes and drop below 1.5V. These dynamic changes are not fully reflected when reading out the status via GPIO2.

Table 25. ProtocolOptions

Field	Length/ BitIndex	Description
ProtocolOptionsA	1	ProtocolOptions (Byte A)
	Bit 7	Controller session key usage, see <a href="#">Section 6.4.7</a>
		'0': Disabled (default)
		'1': Enabled
	Bit 6-4	RFU
	Bit 3	Reserved
	Bit 2	ECC-based Card-Unilateral authentication ( <a href="#">ISOInternalAuthenticate</a> )
		'0': Disabled
'1': Enabled (default)		
Bit 1	Reserved	
Bit 0	AES-based Symmetric authentication ( <a href="#">AuthenticateEV2First</a> , <a href="#">AuthenticateEV2NonFirst</a> )	
	'0': Disabled	
	'1': Enabled (default)	
ProtocolOptionsB	1	ProtocolOptions (Byte B)
	Bit 7-5	RFU
	Bit 4	Enable SIGMA-I Verifier for host( <a href="#">ISOGeneralAuthenticate</a> with P1=0x01where host acts as initiator, i.e. starts with 0xA0 message)

Table 25. ProtocolOptions...continued

		'0': Disabled
		'1': Enabled (default)
Bit 3		Enable SIGMA-I Prover for host ( <a href="#">ISOGeneralAuthenticate</a> with P1=0x01 where host acts as responder, i.e. starts with 0xB0 message)
		'0': Disabled
		'1': Enabled (default)
Bit 2		Secure Tunnel variant after SIGMA-I authentication ( <a href="#">ISOGeneralAuthenticate</a> with P1=0x01)
		'0': NTAG EV2 secure messaging
Bit 1		Secure Tunnel strength for SIGMA-I authentication ( <a href="#">ISOGeneralAuthenticate</a> with P1=0x01)
		'0': AES-256 not supported
		'1': AES-256 supported (default)
Bit 0		Secure Tunnel strength for SIGMA-I authentication ( <a href="#">ISOGeneralAuthenticate</a> with P1=0x01)
		'0': AES-128 not supported
		'1': AES-128 supported (default)

Table 26. GPIOxConfig

Field	Length/ BitIndex	Description
GPIOxConfig	1	GPIOx Configuration
	-	<b>[ifGPIOxMode is output (0x02 or 0x05)]</b>
	Bit 7-1	RFU
	Bit 0	Initial state after power-off cycle
		0:Low (i.e. equivalent to after CLEAR operation with <a href="#">ManageGPIO</a> )
		1:High (i.e. equivalent to after SET operation with <a href="#">ManageGPIO</a> )
	-	<b>[elseif GPIOxMode is down-stream power out (0x04)]</b>
	Bit 7-2	RFU
	Bit 1	I2C Support: If enabled, clock configuration is already adapted for future NFCPause I2C interface on power harvesting
		0: disabled
		1: enabled
	Bit 0	If enabled, backpower allows NFC communication (a.o.WTX) during power downstream.
		0: disabled
		1: enabled
-	<b>[else]</b>	
Bit 7-0	RFU	

Application remark:

To enable stable NFC communication (NFCPause feature incl WTX handling) while power downstream is enabled, GPIOxConfig bit 0 (Backpower) must be set to '1' (enabled) and the reference design recommendation for capacitors on VCC and GPIO1 pins must be followed.

Table 27. GPIOxPadCtrl

Field	Length/ BitIndex	Description
GPIOxPadCtrlA	1	GPIOx Pad Control (Byte A)
	Bit7-2	RFU
	Bit1-0	Debounce Filter value: the 2 MS bits of the 10-bit debounce filter value.
GPIOxPadCtrlB	1	GPIOx Pad Control (Byte B)
	Bit7-0	Debounce Filter value (Resolution = 0.1us): the LS 8 bits of the 10 bit debounce filter value. Bit 0 is the LSB. Writing a value of 1 filters out glitches less than 0.1us. Writing a value of 1000 (over the 10 bits) filters out glitches less than 100us
GPIOxPadCtrlC	1	GPIOx Pad Control (Byte C)
	Bit7-3	RFU
	Bit 2	Debounce filter, enables/disables the debounce filter according to the configuration in GPIOxPadCtrlA bits 1-0 and GPIOxPadCtrlB bits 7-0. The debounce filter removes I/O spikes or ringing.
		0:Disable debounce filter
		1:Enable debounce filter of min.5us/max.60us
	Bit1-0	Input filter selection
		00: unfiltered input selected, (filter of 50 ns selected but has no effect)
01: unfiltered input selected, (filter of 10 ns selected but has no effect)		
10: ZIF filtered input selected, filter of 50 ns selected		
11: ZIF filtered input selected, filter of 10 ns selected		
GPIOxPadCtrlD	1	GPIOx Pad Control (Byte D)
	Bit7-5	Input configuration
		000: Input with weak pullup
		001: Input with repeater
		010: Input
		011: Input with weak pulldown
		100: Weak pullup
		101: Weak pulldown
		110: High-impedance (analog I/O)
		111: Weak pulldown
Bit4-1	Output configuration	

Table 27. GPIOxPadCtrl...continued

	0000: I2C S/F and FP Transmit mode (SDA and SCL) and I2C HStranmit mode (only S0xDA), Open drain mode
	0001: RFU
	0010: RFU
	0011: RFU
	0100: GPIO Low-speed mode ( <i>GPIO_LOW_SPEED_1</i> )
	0101: RFU
	0110: GPIO High-speed mode ( <i>GPIO_HIGH_SPEED_1</i> )
	0111: RFU
	1000-1111: Output disabled
Bit 0	Supply selection, depending on the supply voltage the I <sup>2</sup> C signal voltage level must be configured
	0: In case supply voltage > 1.6V
	1: In case supply voltage < 1.6V

Each of the supported options of the command [SetConfiguration](#) requires active authentication granting [AppMasterKey](#) access rights.

The command [SetConfiguration](#) requires [CommMode.Full](#). Information on the authentication and secure messaging-dependent structure of the command can be found in [Section 6.4](#).

The command is rejected if:

- required authentication is not active.
- updating with option 0x02 the ATS
  - with a TL equal to 0 or strictly bigger than 20.
  - with T0 containing an FSCI > 0x8, as the PICC supports up to 256-byte command size, see [Section 6.1.1](#).

When configuring the SAK with Option 0x03, NTAG X DNA shall accept any value, but:

- bit 2 of SAK1 (i.e. b3 according to the numbering in [\[3\]](#)) is ignored and always set to '1' indicating UID incomplete.
- bit 2 of SAK2 (i.e. b3 according to the numbering in [\[3\]](#)) is ignored and always set to '0' indicating UID complete.

A change in this configuration is guaranteed after the next power-off reset.

When configuring the ATQA with Option 0x0C, NTAG X DNA shall accept any value, but bit 7-6 of LSB (i.e. b8-b7 according to the numbering in [\[4\]](#)) are ignored and set according to the actual UID length.

A change in this configuration is guaranteed after the next power-off reset.

Option 0x0D configuration will only be applied after the next power-off reset. By default, the REQS and WUPS are set to 0x7A and 0x7D respectively, as defined in [Section 6.1.4](#). If SilentMode Bit 1 is set, customized REQS and WUPS are to be given. The most significant bit of the given REQS and WUPS is ignored. REQS and WUPS cannot be set to the same value. If customized REQS/WUPS are given while the silent mode is disabled (Bit 0 is '0'), these values are ignored.

Option 0x0E configurations for enhanced privacy can after enabling be disabled again (contrary to e.g. Random ID but similar to the other configuration options). If configuring [AppPrivacyKey](#) to a value that does not map to a symmetric key (i.e. 0x05 or bigger), this means that the access right can only be achieved through ECC-based

authentication. If disabling the Originality Check, this means both the [ISOInternalAuthenticate](#) and the read-out of the Cert.Orig will be rejected.

Options 0x0F and 0x10 configure the communication interfaces of the product, and what cryptographic protocols are available over each interface. Extreme care must be taken when configuring these options as e.g. disabling both interfaces makes the product unusable. Also, option 0x10 does not check the provided I2CAddress against reserved addresses as specified in [\[17\]](#).

Option 0x11 allows for configuring the GPIO pins and related access conditions for further managing and/or reading them, see also [Section 6.14](#). Values related to specific modes are not checked for consistency. This means it is the user responsibility to provide a meaningful configuration. Even if not applicable for the configured mode, the provided values are stored and returned by [GetConfiguration](#).

When configuring an NFCPauseFile, NTAG X DNA does not check if the file exists and is of a [FileType.StandardData](#).

A change in the GPIO configuration is guaranteed after the next power-off reset.

Option 0x14 allows timers as detailed in [Section 6.16](#). A change in the HWDT configuration is guaranteed after the next power-off reset.

Option 0x15 configures some aspects of the generic Crypto API, see [Section 6.13](#). Asymmetric and symmetric cryptography can be separately enabled through the Support byte. AccessCondition defines the communication mode and required access rights for [CryptoRequest](#). The default is [CommMode.MAC](#) and [AppMasterKey](#) access rights. ChangeAC defines the access condition for changing [CryptoRequestKeys](#) with [ChangeKey](#). The default is requiring [AppMasterKey](#) access rights. Next to these slot policies for the Transient and Static Buffers slots can be configured. By default, those are set to 0x0000, i.e. they must be configured to enable Transient and Static Buffer usage. It is recommended to configure more strict policies depending on the targeted use case, especially if the [CryptoRequest](#) is changed to free or free over I2C access. Any policy that is not explicitly updated remains unchanged.

Option 0x17 configures aspects of HALT and related wake-up Configuration. HALT refers here to the internal power-saving state when VCC is supplied, i.e. not to be confused with ISO/IEC 14443 HALT state. If GPIOx reset is disabled before entering HALT state, the GPIO pin remains its state. However, when leaving the HALT state, the device goes through a POR cycle, and therefore the GPIO pins will at that moment go through the High-Z state.

The HALT current depends on the GPIO pin configuration. Floating GPIO inputs result in increased HALT currents. To avoid increased HALT currents due to floating GPIO inputs the following shall be considered:

1. If GPIOwake-up is enabled internal pull-ups are activated and no floating input behavior can occur.
2. If GPIOwake-up is disabled and if bit 1 (reset) is disabled only with an external pull-up resistor increased HALT currents can be avoided.

\*

NFC field and I2C address wake-up are enabled by default. NFC field wake-up being enabled, means that as long as an NFC field is present, the NTAG X DNA will immediately wake up again when entering HALT state. The RDAC configuration is only relevant if NFC field wake-up is disabled. If enabled, RDAC must be configured to 0x00. However, this is not checked by the implementation. Also, if GPIO2 is already pulled down, the NTAG X DNA will immediately wake up again when entering HALT state. The SDA cycle and GPIO wake-up are disabled by default.

Option 0xFF allows deferring some configurations, see [Section 6.6.3.1](#).

Option 0xFF allows locking the other configurations. A bitmap *Lock map* is to be provided. This is sent LSB first, i.e. to lock Option 0x00, Bit 0 of the first transmitted byte must be set. Setting a bit for a nonsupported option (RFU or Reserved) does not have any effect. Once a configuration is locked, it cannot be unlocked, i.e. setting a bit to 0 does not change the current state.

All configurations can on request get customer-specific values through the OEF specification, instead of the default values listed here.

**6.6.3.3 Command GetConfiguration**

[GetConfiguration](#) is retrieving card or application configuration settings. Its specifications can be found in [Section 7.4.3](#).

If no configuration option byte is specified, then manufacturer data like the NXP Product Features Map is returned. When retrieving the Crypto API Management, i.e. Option 0x15, always all eight TB Policies are returned. If a policy has not been configured explicitly, the default value of 0xFFFF is returned.

The [GetConfiguration](#) is rejected at the PICC level.

The [GetConfiguration](#) is subject to the same access restrictions as the [SetConfiguration](#) i.e.it is subject to [CommMode.Full](#), requiring [AppMasterKey](#) access rights.

**6.6.3.4 Memory management**

The nonvolatile memory available for user data is allocated in blocks of 32 bytes.

The user memory is available for creation of the following data items (including overhead):

- [FileType.StandardData](#) files and [FileType.Counter](#) files, see [Section 6.8.5](#).

Table 28. Supported memory configurations

Memory configuration	Size in bytes	Size in blocks
8 kB	8192	0x0100
16 kB	16384	0x0200

Commands, which have an impact on the memory structure itself activate an automatic mechanism that protects the application and file structure from getting corrupted. If the card is unpowered during command execution, it is ensured that on the next activation the memory structure is automatically updated such that the card behaves either exactly as it was before the command execution, or as it would have been after having completed a successful execution.

**6.6.3.4.1 Free Memory with Command FreeMem**

The available free user memory on the card is returned with [FreeMem](#) as defined in [Section 7.4.1](#).

No parameters are passed with this command.

The memory size in bytes available is returned as an unsigned integer.

If the PICC is authenticated, the command [FreeMem](#) requires [CommMode.MAC](#). Otherwise, [FreeMem](#) is transmitted in plain. Information on the authentication and the secure messaging-dependent structure of the command can be found in [Section 6.4](#).

**6.7 Symmetric Key Management**

**6.7.1 Key Types**

NTAG X DNA supports symmetric key types as defined in [Table 29](#).

As shown in the table, the different key types are represented by two bits.

Table 29. Supported key types

KeyType	BitRepresentation	Description
<a href="#">KeyType.AES128</a>	10	AES-128keys
<a href="#">KeyType.AES256</a>	11	AES-256keys

This representation is used at several places in the document.

[KeyType.AES128](#) and [KeyType.AES256](#) keys are stored in resp. 16 bytes or 32 bytes and are handled according to [6].

## 6.7.2 Key Versioning

NTAG X DNA supports the versioning of symmetric keys by relating with each key a 1 byte key version number. The version of any addressable symmetric key can be read using [GetKeyVersion](#).

## 6.7.3 Symmetric Keys

Symmetric application keys and their usage are defined in [Table 30](#). They are used to manage the security of the application like file access control. Some of them can have additional roles assigned, like being required for key changing. An overview is given in [Section 6.7.3.1](#).

These roles and other key related configurations are defined via the key settings, see [Section 6.7.3.2](#).

Table 30. Keys at application level

Key Identifier	Key number	Change Key	Can be used for Authentication
<i>Addressable keys:</i>			
<a href="#">AppMasterKey</a>	0x00	<a href="#">AppMasterKey</a>	yes
<a href="#">AppKey</a>	0x00..0x04	<a href="#">AppMasterKey</a>	yes
<a href="#">SDMMetaReadKey</a>	0x00..0x04	<a href="#">AppMasterKey</a>	yes
<a href="#">SDMFileReadKey</a>	0x00..0x04	<a href="#">AppMasterKey</a>	yes
<a href="#">AppPrivacyKey</a>	0x00..0x04	<a href="#">AppMasterKey</a>	yes
<a href="#">CryptoRequestKey</a>	0x10..0x17	Configured via <a href="#">Set Configuration</a> Option 0x15 ChangeAC	no

### 6.7.3.1 AppMasterKey

The [AppMasterKey](#) always has the key number 0x00.

The [AppMasterKey](#) can be a KeyType.AES128 or KeyType.AES256 key as set when changing the key with [ChangeKey](#). When changing the key type of the [AppMasterKey](#), the key type of all [AppKeys](#) change.

A successful authentication with the [AppMasterKey](#) is required to change any application key including the [AppMasterKey](#) itself with the [ChangeKey](#) command.

### 6.7.3.2 AppKey

The application of the NTAG X DNA includes 5 application keys with key numbers 0, 1, 2, 3, 4.

At delivery, all [AppKeys](#) will be set to the default value of all zero bytes for key value and version, having KeyType.AES128, or they can be set via trust provisioning, see [Section 6.18.3](#).

A [AppKey](#) can be a KeyType.AES128 or KeyType.AES256 key depending on the key type of the [AppMasterKey](#).

The [AppKeys](#) are changeable with [ChangeKey](#) with an active authentication with [AppMasterKey](#).

**Remark:** If not done through trust provisioning, it is highly recommended to change all 5 keys at personalization, even if not all keys are used in the application.

### 6.7.3.3 [SDMMetaReadKey](#)

The [SDMMetaReadKey](#) is one of the 5 [AppKey](#). Which key is used is configured via [ChangeFileSettings](#) by adjusting the SDMMetaRead access rights, see [Section 6.11.2.1](#). [SDMMetaReadKey](#) is used to encrypt PICCData before mirroring.

As the [SDMMetaReadKey](#) refers to an [AppKey](#), it is changeable with [ChangeKey](#) with an active authentication with the [AppMasterKey](#).

As the [SDMMetaReadKey](#) refers to an [AppKey](#), it is available for authentication.

### 6.7.3.4 [SDMFileReadKey](#)

The [SDMFileReadKey](#) is one of the 5 [AppKey](#). Which key is used is configured via [ChangeFileSettings](#) by adjusting the SDMFileRead access rights, see [Section 6.11.2.1](#). [SDMFileReadKey](#) is used for Secure Dynamic Messaging.

As the [SDMFileReadKey](#) refers to an [AppKey](#), it is changeable with [ChangeKey](#) with an active authentication with the [AppMasterKey](#).

As the [SDMFileReadKey](#) refers to an [AppKey](#), it is available for authentication.

### 6.7.3.5 [AppPrivacyKey](#)

The [AppPrivacyKey](#) is the [AppKey](#) identified by the key number specified with [SetConfiguration](#) Option 0x0E if this feature is enabled.

Once enabled, authentication with this [AppPrivacyKey](#) is required for [GetCardUID](#).

### 6.7.3.6 [CryptoRequestKey](#)

The [CryptoRequestKeys](#) can be used for generic cryptographic operations.

An [CryptoRequestKey](#) is a KeyType.AES128 or KeyType.AES256 key.

The [CryptoRequestKeys](#) are changeable with [ChangeKey](#) according to the ChangeAC configuration of [SetConfiguration](#) Option 0x15. By default, an active authentication with [AppMasterKey](#) is required. When changing the key, the key type is defined, i.e. KeyType.AES128 or KeyType.AES256, and potential restrictions on the usage are specified through the given KeyPolicy. At delivery, by default, this KeyPolicy is set to 0x0000, i.e. disabling the key for any functionality.

The [CryptoRequestKeys](#) are not available for authentication.

## 6.7.4 Key Management Commands

This section gives the overall description of the key management commands as most of them apply to both PICC and application level.

### 6.7.4.1 Command ChangeKey

Changing keys is possible with the command [ChangeKey](#) as defined in [Section 7.5.1](#). The command is also rejected if there is no active authentication with the relevant change key.

For the application level, all [AppKeys](#), including [AppMasterKey](#), require authentication with [AppMasterKey](#). [CryptoRequestKeys](#) require authentication granting [SetConfiguration](#) Option 0x15 ChangeAC access rights. By default this is also [AppMasterKey](#) authentication. The required access rights can also be achieved through asymmetric authentication, see [Section 6.5](#).

Under EV2 Secure Messaging, i.e. if in [VCState.AuthenticatedAES](#) or in [VCState.AuthenticatedECC](#), the secure messaging is as applied under [CommMode.Full](#), see [Section 6.4.6.9](#). For the plaintext, two cases can be distinguished when targeting [AppKeys](#), i.e. `KeyNo 0x00` until `0x04`:

**Targeted key equal to authenticated key** If the targeted key is equal to the authenticated key (i.e. `KeyNo==getKeyNo(AuthKey)`), the plaintext is constructed as follows:

- [KeyType.AES128](#): `KeyData = NewKey||KeyVer(16 + 1 byte)`
- [KeyType.AES256](#): `KeyData = NewKey||KeyVer(32 + 1 byte)`

*NewKey* is the new key. *KeyVer* is the related key version.

The normal EV2 secure messaging for [CommMode.Full](#) is applied on the command. The response is sent in plain, as the authentication is lost (see below).

In [VCState.AuthenticatedECC](#), this case cannot occur. In [VCState.AuthenticatedAES](#), this case applies only if targeting [AppMasterKey](#).

**Targeted key different from authenticated key** If the targeted key is not equal to the authenticated key (i.e. `KeyNo!=getKeyNo(AuthKey)`), the plaintext is constructed as follows:

- [KeyType.AES128](#): `KeyData = (NewKey⊕OldKey)||KeyVer||CRC32NK(16+ 1 + 4 byte)`
- [KeyType.AES256](#): `KeyData = (NewKey⊕OldKey)||KeyVer||CRC32NK(32+ 1 + 4 byte)`

*NewKey* is the new key value, while *OldKey* is the old key value currently present in the targeted key entry. If the key types of the *NewKey* and *OldKey* differ, the *OldKey* is truncated or padded with zeros to match the target key type size. *KeyVer* is the new version.

The *CRC32NK* is the 4-byte CRC value computed over *NewKey*. The CRC is computed according to IEEE Std 802.3-2008 (FCS Field)[22].

The normal EV2 secure messaging for [CommMode.Full](#) is applied on both the command and the response.

**Note:** In [VCState.AuthenticatedECC](#), this case always applies. In [VCState.AuthenticatedAES](#), this case applies always if not targeting [AppMasterKey](#).

When targeting [CryptoRequestKeys](#), i.e. `KeyNo 0x10` until `0x17`, always the first case applies. This means it is not required to prove knowledge of the old key for [CryptoRequestKeys](#). The plaintext consists of the new key value concatenated with the key version, i.e. `NewKey||KeyVer`. Depending on the *ChangeAC* access condition, key updating of [CryptoRequestKeys](#) may be allowed in [VCState.NotAuthenticated](#). In this case, the *KeyData* is sent in plain as no secure messaging applies. If used, it must be judged, via a system security assessment on the targeted use case, if this configuration creates a security risk.

The key value (*NewKey*) and the related key version (*KeyVer*) retrieved are used to change the targeted key. If the length does not match with the targeted key type, the command is rejected.

If targeting the [AppMasterKey](#) or [CryptoRequestKeys](#), the key type is updated with the type specified in `KeyNo[b7..6]`. When changing the key type of the [AppMasterKey](#), also the key type of all other [AppKeys](#) change, by truncating the key values if changing from [KeyType.AES256](#) to [KeyType.AES128](#), or padding with zero bytes if changing from [KeyType.AES128](#) to [KeyType.AES256](#).

If targeting [CryptoRequestKeys](#), via the *KeyPolicy*, which is only present in this case, the allowed cryptographic functionality that can be executed with the targeted key can be restricted. It is not allowed to enable for a key both HMAC-based (bit 8-7) and AES-based (bit 6-0) algorithms.

If the key used for current active authentication [AuthKey](#) is changed, then the authentication is invalidated. The PICC moves into [VCState.NotAuthenticated](#).

### 6.7.4.2 Command GetKeySettings

Retrieving key settings is possible with the command [GetKeySettings](#) as defined in [Section 7.5.2](#).

At application level, an authentication with the [AppMasterKey](#) is required. At PICC level, where only option 0x01 is supported, no authentication is required.

If no [Option](#) is given, the following values are returned:

- *KeySetting* is set to 0x03, i.e. compatible to the AppKeySettings on a MIFARE DESFire product.
- Bit 7-6 of *MaxNoOfKeys* represents the key type of the application, encoded as defined in [Table 29](#). This key type can be changed through updating the [AppMasterKey](#). Bit5-0 is set to the number of application keys, i.e. 0x05.

If an [Option](#) is given, the metadata of a specific key group is returned.

Table 31. [GetKeySettings](#) Key Groups

Option	KeyGroup
0x00	<a href="#">CryptoRequestKeys</a>
0x01	<a href="#">ECCPrivateKeys</a>
0x02	<a href="#">CARootKeys</a>

Under active authentication, the command [GetKeySettings](#) requires [CommMode.MAC](#). Information on the authentication and the secure messaging-dependent structure of the command can be found in [Section 6.4](#).

### 6.7.4.3 Command GetKeyVersion

Getting the key version of an addressable key is possible with the command [GetKeyVersion](#) as defined in [Section 7.5.3](#).

*KeyNo* indicate which information is requested. If the key does not exist, the command is rejected. When retrieving a key version, a single byte *KeyVer* is returned holding the key version.

This command can be issued without an active authentication, but if there is an active authentication the command [GetKeyVersion](#) requires [CommMode.MAC](#). Information on the authentication and the secure messaging-dependent structure of the command can be found in [Section 6.4](#).

## 6.8 Asymmetric Key Management

NTAG X DNA distinguishes private and public keys and the way that they are managed:

- [ECCPrivateKey](#): This is the private key of an asymmetric ECC key pair, which is used to authenticate the NTAG X DNA toward external parties. The management of these keys is detailed in [Section 6.8.1](#).
- [CARootKey](#): This is the public key of an asymmetric ECC key pair, which is used to authenticate an external party toward the NTAG X DNA. This key is written to the NTAG X DNA with [ManageCARootKey](#). This is further detailed in [Section 6.8.2](#).

## 6.8.1 [ECCPrivateKey](#) Management

### 6.8.1.1 Command [ManageKeyPair](#)

The generation of [ECCPrivateKeys](#) is possible with the command [ManageCARootKey](#).

NTAG X DNA supports up to five ECC Key Pairs. The key pairs are associated with a specific curve via [CurveID](#).

Each ECC key pair is assigned to a specific application area and potentially to a specific protocol via [KeyPolicy](#). Typically, best security practice is to use each key for a single purpose. Therefore, if allowing multiple usages for the same key, the implication from security perspective must be assessed.

Generation of a new key pair requires the access condition and communication mode as defined in the configuration parameters (see [SetConfiguration](#) Option 0x12). By default, [CommMode.Full](#) is applied, requiring authentication granting [AppMasterKey](#) access rights. Key replacement requires write-access as specified with [ECCPrivateKey](#) was created.

During key pair generation, the private key is securely stored on-card and the public key is returned to the caller. In case of import, the private key is to provided via [PrivateKey](#). In this case, the public key is not returned.

It is also possible to only update the metadata, i.e. KeyPolicy and access rights, of an existing key entry. This will not affect the current key value. For metadata update, also WriteAccess as configured for the targeted key entry is required. In this case, the command is rejected if the [CurveID](#) is not set to the curve associated with the current key.

### 6.8.1.2 [ECCPrivateKey](#) Key Usage Limit

To allow mitigating potential future attack scenarios, [ECCPrivateKeys](#) can be configured with a key usage limitation. This allows limiting the amount of private key computations, and therefore related trace collection for side-channel attacks. Next to attack mitigation, this feature can also be used to limit the usage of a card/device. Potentially, the limit can be increased in the field, e.g. if the end user pays for additional service. The key usage limitation (KeyUsageCtrLimit) is configured through [KUCLimit](#).

Once enabled for a particular [ECCPrivateKey](#), any private key usage is counted through a KeyUsageCtr associated with that [ECCPrivateKey](#). This means that the KeyUsageCtr shall be incremented by one before the private key operation of the following operations:

- [ISOInternalAuthenticate](#) for Card-Unilateral Authentication, see [Section 6.4.3](#).
- [ReadData](#) or [ISOReadBinary](#) when applying Secure Dynamic Messaging with ECDSa SDMSIG, i.e. only when SDMSIG is targeted to be read out, see [Section 6.4.8.10](#).
- [CryptoRequest](#) with action 0x03 for ECC signature generation, see [Section 7.10.3](#). Note that in case of Initialize/Update/Finalize flow, the counter is incremented on the Finalize-step.
- [CryptoRequest](#) with action 0x05 for ECC Diffie-Hellman, see [Section 7.10.5](#). Note that here the counter is only incremented in the Single-step flow, as the Tow-step flow does not support [ECCPrivateKey](#).
- [ISOGeneralAuthenticate](#) for SIGMA-I, see [Section 6.4.2](#):
  - NTAG X DNA acting as Responder: before B1 response
  - NTAG X DNA acting as Initiator: before A1 response

**Note:** Any updates to the KeyUsageCtr are written with anti-tearing protection, guaranteeing that the counter will in case of tearing either hold the previous or the targeted value.

If the configured KeyUsageCtrLimit has been reached, the related [ECCPrivateKey](#) will be disabled. This means that the key cannot be used for private key computations, though the key entry can still be updated (and potentially reenabled) if the required authentication to do so can still be gained. If the KeyUsageCtrLimit is disabled, private key operations are not counted.

When only updating metadata with [ManageKeyPair](#), it is possible to disable or change the `KeyUsageCtrLimit` without affecting the current `KeyUsageCtr` value. Note that putting the limit to a value equal or lower than the current value, will immediately disable the key entry. When changing the current key value through an import or generate key pair action, the current `KeyUsageCtr` value shall be reset to zero.

It is also possible to freeze the current `KeyUsageCtrLimit`. This can be done through [KeyPolicy](#) Bit 15. Once the `KeyUsageCtrLimit` has been frozen, it cannot be updated anymore. This means that a [ManageKeyPair](#) updating metadata will be rejected if [KUCLimit](#) has a value different from the currently configured `KeyUsageCtrLimit` or if [KeyPolicy](#) Bit 15 is not set. Note that it is still possible to change the limit configuration by generating or importing a new key pair.

Enabling the key usage limit feature may create a denial-of-service risk. For typical use cases, the risk should be limited if e.g. configuring a limit of one million, or if preceding authentication of the external party is required before the NTAG X DNA private key operation.

**Note:** It is essential to properly protect the [ECCPrivateKey](#) write access, as the right to update the key entry also allows to update and/or disable the `KeyUsageCtrLimit`.

### 6.8.1.3 [ECCPrivateKey](#) Information Retrieval

NTAG X DNA supports information retrieval with regard to [ECCPrivateKey](#) by [GetKeySettings](#) as defined in [Section 7.5.2](#).

NTAG X DNA does not support exporting private keys or the related public keys. Note that the related public key is typically stored via a certificate in a [FileType.StandardData](#) file. If the certificate is not created at the time of [ECCPrivateKey](#) generation or import, the public key may be temporarily stored in the file and later overwritten with the certificate. Note that this means one needs to be careful when generating a key pair [ManageKeyPair](#) and putting the `WriteAccess` condition to `0xF`. If the public key in the response gets lost, one is not able to regenerate the key entry. Therefore, it is not recommended to put `WriteAccess` to `0xF` before the public key has been received.

## 6.8.2 [CARootKey](#) Management

### 6.8.2.1 Command [ManageCARootKey](#)

The writing of [CARootKeys](#) is possible with the command [ManageCARootKey](#) as defined in [Section 7.6.2](#).

NTAG X DNA supports up to five [CARootKeys](#).

The public keys are associated with a specific curve via [CurveID](#). Note that NTAG X DNA does not validate the provided public key.

Each [CARootKey](#) has an associated set of access rights via [AccessRights](#) which can be granted to the host after successful authentication depending on the presented certificates. Note that [AccessRights](#) is encoded LSB first.

All [CARootKeys](#) can optionally be associated with a trusted issuer name via [IssuerLen](#) and [Issuer](#). The full Issuer byte string, including SEQUENCE tag and length must be provided. If a trusted issuer name is set, this is compared against the Issuer field of the public key certificate provided during the authentication. In case of chaining, the (grand-)parent certificate Issuer must match. Note that the implementation stores a hash of the provided Issuer to allow for fixed memory consumption.

Creation of [CARootKeys](#) requires the access condition and communication mode as defined in the configuration parameters (see [SetConfiguration](#) Option `0x12`). By default, [CommMode.Full](#) is applied, requiring authentication granting [AppMasterKey](#) access rights. Updating an existing [CARootKey](#) requires write-access as specified with [WriteAccess](#) when the entry was created.

If a certificate cache is enabled, see [SetConfiguration](#) Option 0x13, the cache will be flushed on updating a [CARootKey](#).

### 6.8.2.2 [CARootKey](#) Information Retrieval

NTAG X DNA supports information retrieval with regards to [CARootKey](#) by [GetKeySettings](#) as defined in [Section 7.5.2](#).

## 6.8.3 PICC/MF level

### 6.8.3.1 [ECCPrivateKey](#) entries

At PICC or MF level, in the default configuration, the NTAG X DNA is trust-provisioned during manufacturing with one key pair from which the private keys are stored on the NTAG X DNA as [ECCPrivateKeys](#) for the purpose of originality checking. This is further detailed in [Section 6.18.1.1](#).

## 6.8.4 Application/DF level

### 6.8.4.1 [ECCPrivateKey](#) entries

NTAG X DNA supports up to five [ECCPrivateKey](#) entries.

### 6.8.4.2 [CARootKey](#) entries

NTAG X DNA supports up to five [CARootKey](#) entries.

## 6.8.5 Memory Consumption

Memory allocation is done in 32-byte blocks, see [Section 6.6.3.4](#).

The memory for asymmetric keys is allocated at their creation and is defined as follows:

- [ECCPrivateKey](#): three blocks.
- [CARootKey](#): four blocks.

## 6.8.6 Certificate Cache

The NTAG X DNA supports a cache of validated public keys. This is used to accelerate protocol execution time by removing the need to validate public key certificates that have been previously verified. The cache uses a look-up mechanism, which allows a certificate to be validated if its parent has been previously verified. Use of the cache is controlled via a configuration option. When enabled, the cache is populated automatically by the NTAG X DNA during protocol execution.

If no intermediate cache entry is located, then the NTAG X DNA shall check for a matching root CA public key. If no entry is found, then verification shall be sequentially tried using all CA public key entries, which were loaded without associated issuer information.

The cache shall be partitioned into entries for end-leaf public-keys and entries for parent/grand-parent public keys i.e. public keys belonging to intermediate certificates. Each cache entry shall be stored with its expiry date. Although the NTAG X DNA has no notion of the current time, it does keep track of the 'latest time'. This is the most recent validity time from a validated certificate. The cache replacement scheme shall be 'least recently used'; where the most recently used entries are retained. However, all expired certificates shall be flushed from the cache.

The size of the cache is determined by the CA Root Key cache configuration parameters. [Table 32](#) illustrates a cache with 5 end-leaf slots and 2 intermediate certificate slots. The cache is created using the [SetConfiguration](#) command. The cache can only be created once and cannot be resized.

Table 32. Certificate Cache Example

End Leaf Certificates				Intermediate Certificates			
Cache Entry Num	Public Key Certificate Hash	Public Key	Expiry Date	Cache Entry Num	(Optional) CRC-16 of Certificate Subject Name	Public Key	Expiry Date
Slot 1				Slot 1			
Slot 2				Slot 2			
Slot 3							
Slot 4							
Slot 5							

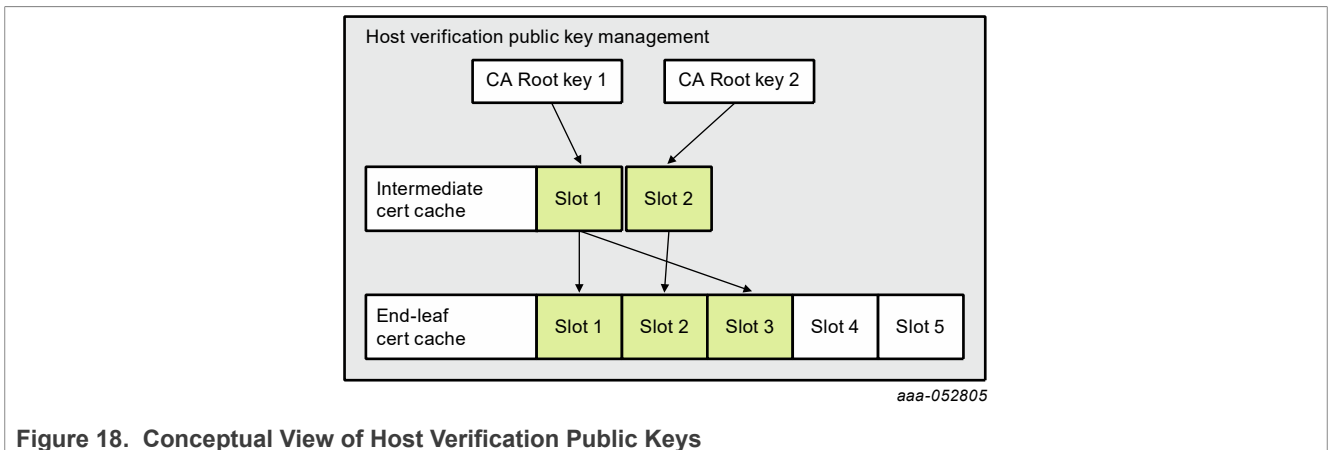

Figure 18. Conceptual View of Host Verification Public Keys

[Figure 18](#) represents how the cache would be populated for a use case where NTAG X DNA was authenticated with three different hosts with the hosts certificate chains as follows:

- Host 1: leaf cert 1 -> intermediate cert 1 -> CA Root Key 1
- Host 2: leaf cert 2 -> intermediate cert 2 -> CA Root Key 2
- Host 3: leaf cert 3 -> intermediate cert 1 -> CA Root Key 1

## 6.9 Certificate Management

### 6.9.1 ECC Certificate Repository Management

The NTAG X DNA supports certificate repositories. A certificate repository provides storage for the credentials required for the NTAG X DNA to execute the SIGMA-I mutual authentication protocols. Construction of a certificate repository consists of the following steps:

- Create certificate repository. Note the maximum memory specified for the repository is allocated on creation. This size may be defined as larger than initially required to allow increasing data items after resetting a repository.
- Load one or more public key certificate
- Load one or more certificate mapping table (optional)

- Activate the certificate repository

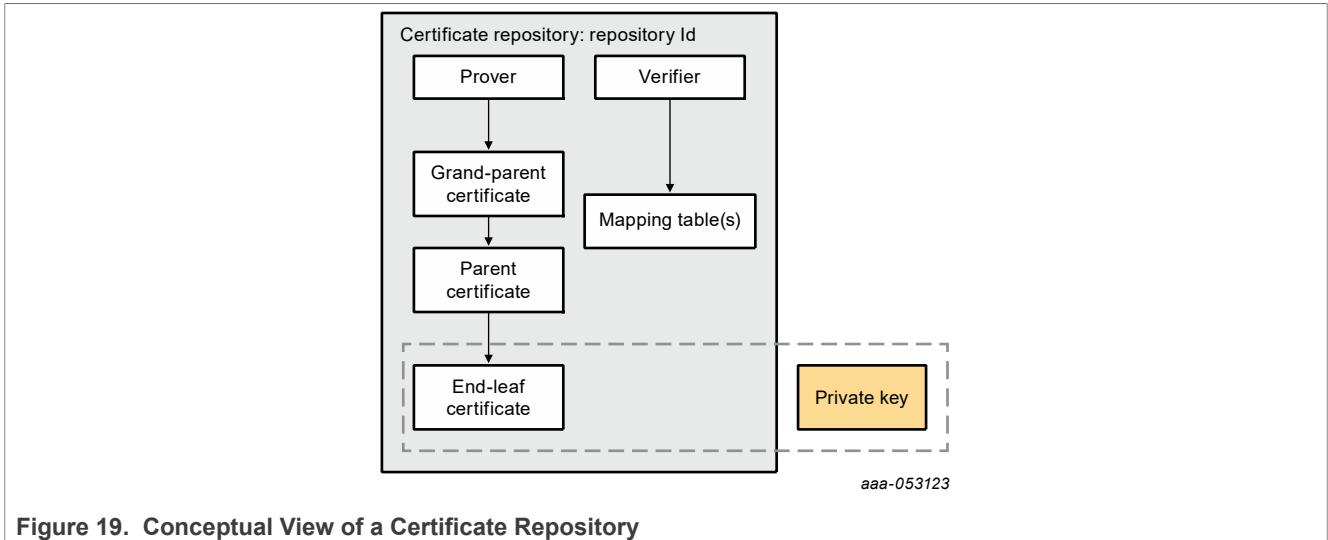

Figure 19. Conceptual View of a Certificate Repository

The certificate repository is populated and activated using the ManageCertRepo command outlined in [Section 7.7.1](#). The access condition defined in the NTAG X DNA's configuration parameters is used for repository creation. The Read and Write/Reset access conditions provided during repository creation/reset otherwise apply. The command does not return any response data.

### 6.9.1.1 Create Certificate Repository

Creation of the certificate repository requires:

- the identity of the on-card private key to be associated with the repository
- a repository identifier used to personalize the repository and to access the repository during algorithm execution

The format of the create certificate repository command data is defined in [Table 131](#).

### 6.9.1.2 Load Public Key Certificate Chain

The certificate chain shall include an end-leaf certificate and may optionally include up to two intermediate public key certificates. This enables support of a certificate chain four deep because the root CA public key (trusted root of the chain) is stored on the receiving entity (the verifier). Each certificate has its own public key and associated algorithm, therefore, chains may include a mix of algorithms.

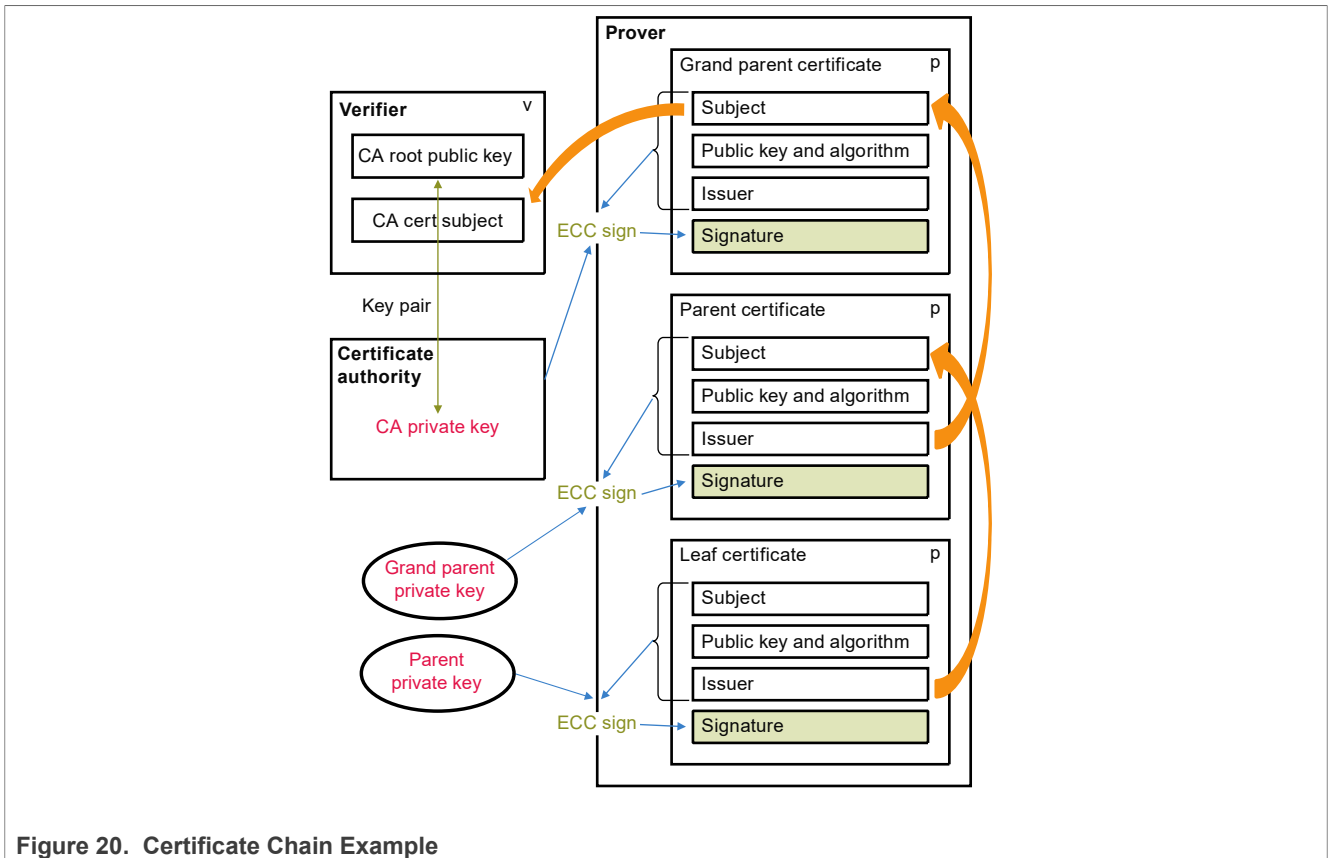

Figure 20. Certificate Chain Example

A separate command is required to load each certificate in the chain. The certificate repository supports loading either compressed or uncompressed certificates. If a compressed end-leaf certificate is loaded, then the hash of the associated uncompressed certificate also must be provided (this is required for SIGMA-I protocol execution). The command format is outlined in [Table 132](#).

The NTAG X DNA shall not verify the certificate chain or certificate hash values during loading.

### 6.9.1.3 Certificate Mapping Table

The NTAG X DNA supports the X.509 certificate format for host certificates. This format has a defined certificate structure:

```

Certificate ::= SEQUENCE {
    tbsCertificate          TBSCertificate,
    signatureAlgorithm      AlgorithmIdentifier,
    signatureValue          BIT STRING
}

TBSCertificate ::= SEQUENCE {
    version                 [0] EXPLICIT Version DEFAULT v1,
    serialNumber            CertificateSerialNumber,
    signature               AlgorithmIdentifier,
    issuer                  Name,
    validity                Validity,
    subject                 Name,
    subjectPublicKeyInfo    SubjectPublicKeyInfo,
    issuerUniqueID [1] IMPLICIT UniqueIdentifier OPTIONAL,
    -- If present, version MUST be v2 or v3
    subjectUniqueID [2] IMPLICIT UniqueIdentifier OPTIONAL,
    -- If present, version MUST be v2 or v3
}
    
```

```

extensions      [3] EXPLICIT Extensions OPTIONAL
-- If present, version MUST be v3
}

AlgorithmIdentifier ::= SEQUENCE { algorithm OBJECT IDENTIFIER, parameters ANY DEFINED BY
algorithm OPTIONAL }
    
```

6.9.1.3.1 x.509 Wrapping

The NTAG X DNA allows a certificate wrapping to be defined, e.g., PKCS#7. The wrapping basically provides a path, using ASN.1 encoding, to the start of the x.509 certificate, Providing an x.509 wrapping path is optional. If it is not provided, then the NTAG X DNA assumes the x.509 certificate is not wrapped. Wrapping information is loaded using tag 'A0' see [Table 33](#). Following is a wrapping example using CMS/PKSC#7 format:

```

<SEQUENCE> (0x30) [0xyyyy]
{
  <OID> (0x06) [0x09] { 2A864886F70D010702 } -> iso(1) member-body(2)
  us(840) rsadsi(113549) pkcs(1) pkcs7(7) 2

  <CONTEXT SENSITIVE> (0xA0) [0xyyyy]
  {
    <SEQUENCE> (0x30) [0xyyyy]
    {
      <INTEGER> (0x02) [0x01] { 01 } -> version
      <SET> (0x31) [0x00] -> set of DigestAlgorithmIdentifier
      <SEQUENCE> (0x30) [0x0B]
      {
        <OID> (0x06) [0x09] { 2A864886F70D010701 } ->iso(1) member-body(2)
        us(840) rsadsi(113549) pkcs(1) pkcs7(7) 1
      }
      <CONTEXT SENSITIVE> (0xA0) [0xyyyy]
      {
        //x.509 certificate which starts with <SEQUENCE> (0x30)
      }
    }
  }
}
    
```

Table 33. X.509 Certificate Wrap Encoding

Tag	Description
'A0'	<p>The ASN path to the start of the full x.509 certificate e.g. A0 0E 3081A0813081028231823082A083 for the PKSC#7 wrapping outlined above</p> <p>The ASN path consists of pairs of tag qualifier path entries where the qualifier is one of the following:</p> <ul style="list-style-type: none"> <li>0x81 The next ASN tag is nested inside the current element</li> <li>0x82 The next ASN tag is at the same level as the current element</li> <li>0x83 End of list</li> </ul> <p><b>Note:</b> The first entry matching the tag provided is located, therefore, multiple path entries may be required when there are duplicate tags</p>

6.9.1.3.2 Mapping Table Command Data Format

The format of the command data required to load a certificate mapping table is outlined in [Table 133](#)

6.9.1.4 Activate Certificate Repository

Once personalized, the certificate repository must be activated. The format of the certificate repository activation command data is defined in [Table 130](#).

## 6.9.2 Read Certificate Repository

It is possible to read a certificate from a repository or to read a repository's metadata using the [ReadCertRepo](#) command. Reading metadata does not require any authentication; if reading metadata in a secure tunnel then CommMode.MAC is applied. Reading a certificate directly from the repository requires access as defined in the Read access condition set during repository creation/reset. If reading using a standard APDU then the maximum response data length is 239 bytes. The format of the [ReadCertRepo](#) command is defined in [Section 7.7.2](#).

## 6.10 Application Management

NTAG X DNA groups user data into an application. Within an application data is further grouped into files, as described in [Section 6.11](#).

NTAG X DNA only holds one application, which is pre-configured at delivery, as defined in [Section 6.10.2](#).

In [Section 6.10.1](#), it is detailed how applications can be selected.

### 6.10.1 Application Selection

An application can only be selected with [ISOSelectFile](#), see [Section 6.17.1.4](#).

### 6.10.2 Application Definition

NTAG X DNA comes pre-configured with one application. It shall have the following properties for application selection:

- DFName: 0xD2760000850101
- ISOFile Identifier: 0xE110

## 6.11 File Management

NTAG X DNA maintains user data into files of specific types listed in [Section 6.11.1](#). Files are managed through creation, information retrieval and update functions respectively specified in [Section 6.11.4](#), [Section 6.11.3](#) and [Section 6.11.2.3](#). File access can be restricted with an access right management specified in [Section 6.11.2](#).

### 6.11.1 File Types

NTAG X DNA supports the following types of data storage:

- raw data as specified in [Section 6.11.1.1](#)
- monotonic counters as specified in [Section 6.11.1.2](#)

All NTAG X DNA files are defined with a file number and the communication mode that has to be used when accessing the file data. The file number is coded over 1 byte. It is unique per file in an application. The communication mode is defined in [Section 6.4.6.6](#).

#### 6.11.1.1 FileType.StandardData

FileType.StandardData stores the data as raw data byte per byte. Data is accessed by chunk of byte at a certain offset in the data file and with a certain length in byte.

A FileType.StandardData file is created with [CreateStdDataFile](#), see [Section 6.11.4.1](#). As defined in [Section 6.11.6](#), NTAG X DNA holds three FileType.StandardData files at delivery. Next to this, the user can create additional files.

A `FileType.StandardData` file can be read with [ReadData](#) and [ISOReadBinary](#). The data can be written with [WriteData](#) and [ISOUpdateBinary](#).

`FileType.StandardData` is defined by its size in bytes. The size of each of the additional files the user can create, is limited to maximum of 1024 bytes.

Limited anti-tearing protection is foreseen, as it is ensured that the data received in a single frame is written anti-tearing protected, i.e. all targeted data or none of it is updated. In case of chaining, see [Section 6.3.3](#), an NTAG X DNA buffers multiple frames up to the supported FSC size of 256 bytes and write them at once. Note that in this case, if secure messaging applies, incomplete cryptographic blocks within a frame cannot be fully processed. Such a block will then be considered as part of the next frame.

### 6.11.1.2 FileType.Counter

[FileType.Counter](#) stores a 4-byte monotonic counter. This means that the counter can only be incremented and never decremented.

A [FileType.Counter](#) file is created with [IncrementCounterFile](#), see [Section 6.11.4.2](#). As defined in [Section 6.11.6](#), NTAG X DNA does not hold any [FileType.Counter](#) files in the default configuration at delivery.

One of the counters can be enabled as Authentication counter with [SetConfiguration](#) Option 0x16. The Authentication counter is incremented every time a symmetric and/or asymmetric mutual authentication session is initiated. It can also be incremented with [IncrementCounterFile](#). Note that only one [FileType.Counter](#) can have this function. For more details, also on configuring a limit on the number of allowed authentications, see [Section 6.4.5](#).

The other User Counters can be incremented only with [IncrementCounterFile](#). It is not possible to update counters using [WriteData](#) or [ISOUpdateBinary](#).

Any [FileType.Counter](#) file can be read with [GetFileCounters](#). [IncrementCounterFile](#) has built in anti-tearing protection, guaranteeing that the counter will in case of tearing either hold the previous or the incremented value.

## 6.11.2 File Access Rights Management

For a generic introduction on access right management, see [Section 6.5](#) and especially [Section 6.5.1](#) for the encoding of access conditions.

File data is accessed with three different access rights: [FileAR.Read](#), [FileAR.Write](#) and [FileAR.ReadWrite](#). Each of these access rights are permitting the use of a subset of commands defined in [Section 6.11.2.2](#).

In addition, an access right called [FileAR.Change](#) is specified per file permitting [ChangeFileSettings](#) to change the file access rights.

An access right is granted if at least one condition associated to it is satisfied. Such conditions are called access conditions.

The set of access conditions are coded on 2 bytes as shown in [Table 34](#). RFU access conditions are expected to be set to 0xF (for future extensibility).

**Table 34. Set of Access condition coded on 2 bytes**

Bit index	Description	Value
15..12	<a href="#">FileAR.Read</a>	access condition as in <a href="#">Table 18</a> .
11..8	<a href="#">FileAR.Write</a>	access condition as in <a href="#">Table 18</a> .
7..4	<a href="#">FileAR.ReadWrite</a>	access condition as in <a href="#">Table 18</a> .
3..0	<a href="#">FileAR.Change</a>	access condition as in <a href="#">Table 18</a> .

6.11.2.1 Secure Dynamic Messaging Related Access Rights

Additionally, a [FileType.StandardData](#) file can be associated with the following Secure Dynamic Messaging access rights: [FileAR.SDMMetaRead](#), [FileAR.SDMFileRead](#), and [FileAR.SDMCtrRet](#).

The [FileAR.SDMCtrRet](#) is interpreted as the access rights defined above, according to [Table 18](#) and grants access to [GetFileCounters](#). The others have a different interpretation.

The [FileAR.SDMMetaRead](#) is a bit special as it does not define access to certain commands, i.e. by setting this access right one does not affect the policy on when certain commands will be allowed or not. It purely defines the mirroring of [PICCData](#), i.e. whether the [PICCData](#) will be mirrored in plain, encrypted or not at all, see also [Section 6.4.8.3](#). This is interpreted according to [Table 35](#).

Table 35. FileAR.SDMMetaRead values

Condition value	Description
0x0..0x4	<a href="#">SDMMetaReadKey</a> : key number of an <a href="#">AppKey</a> used to encrypt the <a href="#">PICCData</a> before mirroring
0xE	Plain <a href="#">PICCData</a> mirroring
0xF	No <a href="#">PICCData</a> mirroring

The [FileAR.SDMFileRead](#) and [FileAR.SDMFileRead2](#) will, as soon as one of them is different from 0xF, grant free access to [ReadData](#) and [ISOReadBinary](#).

The [FileAR.SDMFileRead](#), as defined in [Table 36](#), allows configuring a symmetric [AppKey](#). This key is used to derive session keys, see [Section 6.4.8.12](#). [SesSDMFileReadMACKey](#) is used for [SDMMAC](#) computation as defined in [Section 6.4.8.8](#) and [Section 6.4.8.9](#). [SesSDMFileReadENCKey](#) is used for file data encryption. See [SDMENCFileData](#) as defined in [Section 6.4.8.6](#) and [Section 6.4.8.7](#).

The [FileAR.SDMFileRead2](#), as defined in [Table 36](#), allows configuring an asymmetric [ECCPrivateKey](#). This key is used for [SDMSIG](#) computation as defined in [Section 6.4.8.10](#) and [Section 6.4.8.11](#). If both [FileAR.SDMFileRead](#) and [FileAR.SDMFileRead2](#) configure a key, an [SDMSIG](#) is computed with the key of [FileAR.SDMFileRead2](#). No [SDMMAC](#) is calculated in this case, but [FileAR.SDMFileRead](#) will still be used for encryption if enabled. [Table 37](#) gives an overview of the possible combinations.

Table 36. FileAR.SDMFileRead values

Condition value	Description
0x0..0x4	<a href="#">SDMFileReadKey</a> : free access, key number of an <a href="#">AppKey</a> that is to be applied for the Secure Dynamic Messaging
0xE	RFU
0xF	No symmetric Secure Dynamic Messaging for Reading

Table 37. FileAR.SDMFileRead2 values

Condition value	Description
0x0..0x4	<a href="#">SDMFileReadKey</a> : free access, key number of an <a href="#">ECCPrivateKey</a> that is to be applied for the <a href="#">SDMSIG</a> calculation
0xE	RFU
0xF	No asymmetric Secure Dynamic Messaging for Reading

Table 38. FileAR.SDMFileRead and FileAR.SDMFileRead2 combinations

FileAR.SDMFile Read	FileAR.SDMFile Read2	SDMENCFileData	SDMMAC	SDMSIG	Comment
<a href="#">AppKey</a>	valid <a href="#">ECCPrivate Key</a>	Yes, mandatory to be enabled	No	Yes	-
<a href="#">AppKey</a>	invalid <a href="#">ECCPrivate Key</a>	Yes, mandatory to be enabled	No	No	Rejected at <a href="#">ChangeFile Settings</a> . If <a href="#">ECCPrivateKey</a> gets invalidated afterward, the static file data is returned at <a href="#">SDMMACOffset</a> .
<a href="#">AppKey</a>	0xF	Yes, if enabled	Yes	No	-
0xF	valid <a href="#">ECCPrivateKey</a>	No	No	Yes	-
0xF	invalid <a href="#">ECCPrivate Key</a>	No	No	No	Rejected at <a href="#">ChangeFile Settings</a> . If <a href="#">ECCPrivateKey</a> gets invalidated afterward, the static file data is returned at <a href="#">SDMMACOffset</a> .
0xF	0xF	No	No	No	-

### 6.11.2.2 Access right association with commands

In [Table 39](#), it is listed to which commands the access rights are granting access to.

Table 39. Command list associated with access rights

AccessRight	Commands
<b>FileAR.Read</b>	<a href="#">ReadData</a> <a href="#">ISOReadBinary</a> <a href="#">GetFileCounters</a> if targeting <a href="#">FileType.Counter</a>
<b>FileAR.Write</b>	<a href="#">WriteData</a> <a href="#">ISOUpdateBinary</a> <a href="#">IncrementCounterFile</a>
<b>FileAR.ReadWrite</b>	<a href="#">ReadData</a> <a href="#">WriteData</a> <a href="#">ISOReadBinary</a> <a href="#">ISOUpdateBinary</a> <a href="#">GetFileCounters</a> if targeting <a href="#">FileType.Counter</a> <a href="#">IncrementCounterFile</a>
<b>FileAR.Change</b>	<a href="#">ChangeFileSettings</a>
<b>FileAR.SDMMetaRead</b>	-
<b>FileAR.SDMFileRead</b>	<a href="#">ReadData</a>

Table 39. Command list associated with access rights...continued

or <b>FileAR.SDMFileRead2</b>	<a href="#">ISOReadBinary</a>
<b>FileAR.SDMCtrRet</b>	<a href="#">GetFileCounters</a> if targeting <a href="#">FileType.StandardData</a>

A command listed in [Table 39](#) is accepted if at least one access condition associated with an access right (could be several) granting access to it is satisfied. If authenticated and the only access conditions satisfied are free access 0xE within FileAR.Read, FileAR.Write, FileAR.ReadWrite and FileAR.Change, then the [CommMode.Plain](#) is to be applied.

If not authenticated, Secure Dynamic Messaging will be applied if access is granted via FileAR.SDMFileRead or FileAR.SDMFileRead2, even if there is free access via one of the other access rights. FileAR.SDMFileRead and FileAR.SDMFileRead2 are not affecting the regular secure messaging, i.e. if authenticated.

**Note:** [GetFileCounters](#) access is only granted via [FileAR.Read](#) and [FileAR.ReadWrite](#) if targeting a [FileType.Counter](#). If targeting a [FileType.StandardData](#), access to [GetFileCounters](#) is only granted via the dedicated Secure Dynamic Messaging [FileAR.SDMCtrRet](#).

A command listed in [Table 39](#) is rejected if there is no satisfied access conditions associated with an access right (could be several) granting access to it. The command returns:

- [Resp.PERMISSION\\_DENIED](#) if all access conditions associated with all access rights granting access to the command are denying any access.
- [Resp.AUTHENTICATION\\_ERROR](#) if at least one access condition associated with one of the access rights granting access to the command requires a valid authentication, while being in [VCState.NotAuthenticated](#), or in [VCState.AuthenticatedAES](#) but authenticated with the wrong key.
- [Resp.CERT\\_ERROR](#) if at least one access condition associated with one of the access rights granting access to the command requires a valid authentication, while being in [VCState.AuthenticatedECC](#) but not having obtained the required access rights from the targeted [CARootKey](#) or reader certificate presented during the authentication.

### 6.11.2.3 Command ChangeFileSettings

[ChangeFileSettings](#) as defined in [Section 7.8.7](#) permits to update the communication mode of a file as specified in [Table 15](#) and the access rights of a file by mean of all its sets of access conditions as specified in [Table 34](#).

The *AccessRights* parameter is mandatory and updates the mandatory set of access conditions and defined in [Table 34](#).

[ChangeFileSettings](#) also allows enabling the Secure Dynamic Messaging and mirroring features, see [Section 6.4.8](#) for more details. Note that it is possible to defer the encryption configurations of the SDM configuration, see [Section 6.6.3.1](#).

If targeting a [FileType.Counter](#), the counter can be enabled as Authentication Counter by setting *FileOption* Bit 6. If another file is currently already enabled as Authentication Counter, the feature will be disabled for the previous file, i.e. only one [FileType.Counter](#) can act as Authentication Counter at a time.

The command is rejected if:

- one of the access conditions is targeting a key that does not exist within the application.
- the PICC level is selected.
- the *FileNo* parameter does not refer to an existing file in the selected application.
- the [FileAR.Change](#) is not granted because it is a no access 0xF.
- the [FileAR.Change](#) is not granted because it requires an authentication with a [AppKey](#) which is currently not active.
- trying to enable Secure Dynamic Messaging on a file where it is not supported.
- the provided configuration for Secure Dynamic Messaging and mirroring is inconsistent according to the conditions of [Section 6.4.8](#), as reflected in [Section 7.8.7](#).

Under active authentication, the command [ChangeFileSettings](#) requires [CommMode.Full](#). There is one exception: if [FileAR.Change](#) of the targeted file is configured to 0xE allowing free access, also under active authentication [CommMode.Plain](#) is to be applied. Information on authentication and secure messaging-dependent structure of the command can be found in [Section 6.4](#).

### 6.11.3 File Information Retrieval

#### 6.11.3.1 Command GetFileSettings

[GetFileSettings](#) as defined in [Section 7.8.5](#) allows to get information on the properties of a specific file. The information provided by this command depends on the type of the file which is queried.

The file from which the settings have to be retrieved is defined by *FileNo* specified over 5 bits. The first part of the returned message is the same for all file types:

- the actual file type, see [Section 6.11.1](#)
- the communication mode as specified in [Table 15](#)
- the access rights of a file by mean of all its sets of access conditions as specified in [Table 34](#).

All subsequent bytes in the response have a special meaning depending on the file type:

- [FileType.StandardData](#): file size over 3 bytes. If Secure Dynamic Messaging, with eventually Deferred Configuration, applies for the targeted file, this is also indicated, and the related parameters are returned.
- [FileType.Counter](#) file: if the authentication Counter is enabled. The command is rejected if:
  - the targeted file does not exist

The command is rejected if:

- the targeted file does not exist

Under active authentication, the command [GetFileSettings](#) requires [CommMode.MAC](#). Information on authentication and secure messaging-dependent structure of the command can be found in [Section 6.4](#).

#### 6.11.3.2 Command GetFileCounters

[GetFileCounters](#) as defined in [Section 7.8.6](#) supports retrieving of the following counter values:

- current values associated with the 24-bit [SDMReadCtr](#) related with a [FileType.StandardData](#) file after enabling Secure Dynamic Messaging, see [Section 6.4.8](#) and [Section 6.11.2.3](#).
- current values associated with the [FileType.Counter](#) files holding a 32-bit counter.

The command is rejected if

- The PICC level is selected
- the targeted file does not exist
- the targeted file is not a [FileType.StandardData](#) file with Secure Dynamic Messaging enabled, or a [FileType.Counter](#) file.
- if targeting [FileType.StandardData](#) file, depending on [FileAR.SDMCtRet](#), permission is always denied or requires authentication.
- if targeting [FileType.Counter](#) file, depending on [FileAR.Read](#) or [FileAR.ReadWrite](#), permission is always denied or requires authentication.

Under active authentication, the command [GetFileCounters](#) requires [CommMode.Full](#) for [SDMReadCtr](#) retrieval. If retrieving the value of a [FileType.Counter](#), the communication mode depends on the configuration of the file. Information on authentication and secure messaging-dependent structure of the command can be found in [Section 6.4](#).

### 6.11.3.3 Command GetFileIDs

[GetFileIDs](#) as defined in [Section 7.8.3](#) returns the complete list of file IDs of all active files of the selected application.

The command takes no parameters.

Each File ID is coded in one byte. Duplicate values are not possible as each file must have an unambiguous identifier.

The response includes all identifiers of all [FileType.StandardData](#) or [FileType.Counter](#) files. For [FileType.StandardData](#), independently of whether they were pre-allocated or created by the user.

The command is rejected if:

- the PICC level is selected.

Under active authentication, the command [GetFileIDs](#) requires [CommMode.MAC](#). Information on authentication and secure messaging-dependent structure of the command can be found in [Section 6.4](#).

### 6.11.3.4 Command GetISOFileIDs

[GetISOFileIDs](#) as defined in [Section 7.8.4](#) returns the complete list of the 2 byte ISO/IEC 7816-4 File Identifiers of all active files within the currently selected application.

The command takes no parameters.

Each File ID is coded in 2 bytes. Duplicate values are not possible as each file must have an unambiguous identifier.

The response includes all identifiers of all [FileType.StandardData](#) files, independently of whether they were pre-allocated or created by the user.

The command is rejected if:

- the PICC level is selected.

Under active authentication, the command [GetISOFileIDs](#) requires [CommMode.MAC](#). Information on authentication and secure messaging-dependent structure of the command can be found in [Section 6.4](#).

### 6.11.4 File Creation

NTAG X DNA supports file creation for `FileType.StandardData` and `FileType.Counter` files.

The file creation commands all share the following parameters: *FileNo*, *FileOption* and *AccessRights*.

The *FileNo* encodes the file number in the range of 0x00 to 0x1F which the new created file should get within the currently selected application. If the file number is already occupied, the file creation fails.

*FileOption* defines the communication mode of the targeted file, see [Section 6.4.6.6](#).

The *AccessRights* define the mandatory access right set of the newly created file. Note that the meaning of these access rights depends on the targeted file type, see [Section 6.11.2.2](#). The command is rejected if one of the access rights targets a key that is not available in the targeted application.

The file creation command is rejected if no application has been selected, i.e. the PICC level is currently selected. An active authentication with the [AppMasterKey](#) is required.

Under active authentication file creation commands require [CommMode.MAC](#).

#### 6.11.4.1 Command CreateStdDataFile

General aspects of file creation, shared by all file creation commands, are described at the start of [Section 6.11.4](#). In addition to the parameters listed above, [CreateStdDataFile](#), as defined in [Section 7.8.1](#), specifies the size of the file in bytes. [FileSize](#) is defined as a 3 byte integer. The file will be initialized with all zero bytes.

Every [FileType.StandardData](#) file within the application, must be created with a 2 byte File Identifier *ISOFileID* to enable ISO/IEC 7816-4 selection with [ISOSelectFile](#).

NTAG X DNA does not limit the amount of files that can be created, other than by the available memory and *FileNo* range.

The size of a created file must not exceed 1024 byte.

#### 6.11.4.2 Command CreateCounterFile

General aspects of file creation, shared by all file creation commands, are described at the start of [Section 6.11.4](#). In addition to the parameters listed above, [CreateCounterFile](#), as defined in [Section 7.8.2](#), specifies the initial value of the counter. [Value](#) is defined as a 4 byte unsigned integer.

If targeting a [FileType.Counter](#), the counter can be enabled as Authentication Counter by setting *FileOption* Bit 6. If another file is currently already enabled as Authentication Counter, the feature will be disabled for the previous file, i.e. only one [FileType.Counter](#) can act as Authentication Counter at a time.

NTAG X DNA does not limit the amount of counters that can be created, other than by the available memory and *FileNo* range.

### 6.11.5 Memory Consumption

Memory allocation is done in 32-byte blocks, see [Section 6.6.3.4](#).

The memory for files is allocated at file creation and can be computed as follows:

- General overhead: 1 block per 2 files within an application.
- [FileType.StandardData](#):  $(FileSize + 31) / 32$
- [FileType.Counter](#): 1 block.

### 6.11.6 File Definition

The NTAG X DNA application as defined in [Section 6.10.2](#) shall hold the following files:

[FileType.StandardData](#) files

- a [FileType.StandardData](#) file of 32 bytes with following properties:
  - FileNo = 0x01; ISO File ID = 0xE103
  - [FileAR.Read](#) = 0xE; [FileAR.Write](#) = 0x0; [FileAR.ReadWrite](#) = 0x0; [FileAR.Change](#) = 0x0
  - Secure Dynamic Messaging and mirroring are not supported for this file.
  - [CommMode.Plain](#)

This file will hold the CC-file according to [\[15\]](#). At delivery it will hold following content:

- CLEN = 0x0017, i.e. 23 bytes
- T4T\_VNo = 0x20, i.e. Mapping Version 2.0
- MLe = 0x0100, i.e. 256 bytes
- MLc = 0x00FF, i.e. 255 bytes
- NDEF-File\_Ctrl\_TLV
  - T = 0x04, indicates the NDEF-File\_Ctrl\_TLV
  - L = 0x06, i.e. 6 bytes
  - NDEF-File File Identifier = 0xE104
  - NDEF-File File Size = 0x0100, i.e. 256 bytes
  - NDEF-File READ Access Condition = 0x00, i.e. READ access granted without any security
  - NDEF-File WRITE Access Condition = 0x00, i.e. WRITE access granted without any security
- Proprietary-File\_Ctrl\_TLV
  - T = 0x05, indicates the Proprietary-File\_Ctrl\_TLV
  - L = 0x06, i.e. 6 bytes
  - Proprietary-File File Identifier = 0xE105
  - Proprietary-File File Size = 0x0080, i.e. 128 bytes
  - Proprietary-File READ Access Condition = 0x82, i.e. Limited READ access, granted based on proprietary methods, after authentication with key 0x2.
  - Proprietary-File WRITE Access Condition = 0x83, i.e. Limited READWRITE access, granted based on proprietary methods, after authentication with key 0x3.

The remainder of the file is set to all 0x00 bytes.

- a [FileType.StandardData](#) file of 256 bytes with following properties:
  - FileNo = 0x02; ISO File ID = 0xE104
  - [FileAR.Read](#) = 0xE; [FileAR.Write](#) = 0xE; [FileAR.ReadWrite](#) = 0xE; [FileAR.Change](#) = 0x0
  - SecureDynamic Messaging and mirroring is supported for this file, but disabled at delivery.
  - [CommMode.Plain](#)
  - By default, this file is set to all 0x00 bytes at delivery. This file will hold the NDEF-file according to [\[15\]](#).
- a [FileType.StandardData](#) file of 128 bytes with following properties:
  - FileNo = 0x03; ISO File ID = 0xE105
  - [FileAR.Read](#) = 0x2; [FileAR.Write](#) = 0x3; [FileAR.ReadWrite](#) = 0x3; [FileAR.Change](#) = 0x0
  - SecureDynamic Messaging and mirroring is not supported for this file.
  - [CommMode.Full](#)
  - By default, this file is set to 0x00 0x7E, followed by all 0x00 bytes at delivery.

This file proprietary file according to [\[15\]](#) that can hold additional confidential information. According to [\[15\]](#), the PLEN field is set to 126 (0x007E) by default at delivery.

All files can on request get customer-specific configurations and contents through commercial customization options, instead of the default values listed here.

After personalization the write access to the [FileType.StandardData](#) files, can be adapted to no access (0xF).

The following access rights for Secure Dynamic Messaging can be configured by the customer, e.g. as follows: [FileAR.SDMMetaRead](#) = 0x4; [FileAR.SDMFileRead](#) = 0x1; [FileAR.SDMCtrRet](#) = 0x2. This is only a recommended setting, other configurations are also possible. In this setting KeyNo 0x4 is used as non-diversified key (e.g. in this case configuring for encrypted UID-retrieval via [PICCData](#)). KeyNo 0x1 is used as read key protecting the file communication and KeyNo 0x2 is used for counter retrieval after mutual authentication.

## 6.12 Data Management

NTAG X DNA maintains user data into files of specific types as described in [Section 6.11](#). The user can access and manage the data through functions specific to file type.

Data can be read, written, or updated. Depending on the file type, data are defined as:

- raw data in [FileType.StandardData](#)

For a user, the access to data is limited by the access rights set at file level as defined in [Section 6.11.2](#) and listed in [Table 39](#).

### 6.12.1 Standard Data Files

#### 6.12.1.1 Command ReadData

Reading data from [FileType.StandardData](#) files is possible with the command as defined in [Section 7.9.1](#).

The data to be read is defined by the file number of the targeted file, the offset in the data file where to start the reading and its size in bytes. The file number specifying the file where to read the data from is given by [FileNo](#) specified over 5 bits as defined in [Section 6.11](#).

The position byte-wise in the data file where to start to read data is given by [Offset](#). Its valid range is from 0x000000 to *FileSize* - 1. The data size to be read is given by [Length](#) specifying the number of bytes. If [Length](#) is equal to 0x000000 then the entire data file has to be read starting from the position specified by the [Offset](#) value. [Length](#) valid range is 0x000000 to *FileSize* - *Offset*.

**Note:** Due to the ISO/IEC 7816-4 wrapping, only supporting short *Le*, see [Section 6.3.2](#), the amount of data read is limited by *Le* as well.

The data is returned in [Data](#). If the number of bytes to send to the PCD does not fit into one single frame, chaining is applied, see [Section 6.3.3](#).

As listed in [Table 39](#), [ReadData](#) is allowed only if at least one of [FileAR.Read](#) and [FileAR.ReadWrite](#) access rights associated with the targeted file is granted.

Additionally, if not authenticated, [ReadData](#) may be granted if Secure Dynamic Messaging for reading is enabled via [FileAR.SDMFileRead](#).

If authenticated, the communication mode depends on the one from the file being accessed as specified in [Section 6.4.6.6](#). Information on authentication and secure messaging-dependent structure of the command can be found in [Section 6.4](#).

At PICC level, the command is rejected.

The [ReadData](#) command can be used to implicitly trigger an NFC Pause, as explained in [Section 6.14.1](#).

### 6.12.1.2 Command WriteData

Writing data to `FileType.StandardData` files is possible with the command as defined in [Section 7.9.2](#).

The location of data to be written is defined by the file number of the targeted file, the offset in the data file where to start the writing and its size in bytes. The file number specifying the file where to write to is given by `FileNo` specified over 5 bits as defined in [Section 6.11](#).

The position byte-wise in the data file where to start to write data is given by `Offset` define on 3 bytes. Its valid range is from `0x000000` to `FileSize - 1`. The data size to be written is given by `Length` specifying the number of bytes defined on 3 bytes. `Length` valid range is `0x000001` to `FileSize - Offset`. The data is passed in `Data` and is, if needed, split in multiple frames depending on the command variant as defined above.

The `FileType.StandardData` does offer limited anti-tearing protection, see [Section 6.11.1.1](#).

For `FileType.StandardData`, data written in a file can be directly returned with `ReadData`, as `FileType.StandardData` does not implements any backup mechanism. Note especially that in case of chaining, data is already written before the integrity has been checked (`CommMode.MAC` or `CommMode.Full`). Therefore, in case of `Resp.INTEGRITY_ERROR`, the content of the file can be corrupted. For this reason, chained writing to `FileType.StandardData` in `CommMode.MAC` or `CommMode.Full` can be disabled with `SetConfiguration`, option `0x04`. Note however, that also here an implementation may buffer multiple chained frames and write them at once. As long as the implementation can guarantee that the MAC is validated before the writing and all targeted data or none are updated, this does not violate the disabled chained writing configuration.

As listed in [Table 39](#), `WriteData` is allowed only if at least one of `FileAR.Write` and `FileAR.ReadWrite` access rights associated with the targeted file is granted.

The communication mode depends on the one from the file being accessed as specified in [Section 6.4.6.6](#). Information on authentication and secure messaging-dependent structure of the command can be found in [Section 6.4](#).

At PICC level, the command is rejected.

## 6.12.2 Counter Files

### 6.12.2.1 Command IncrementCounterFile

Increment the value of a `FileType.Counter` file is possible with the command `IncrementCounterFile` as defined in [Section 7.9.3](#).

The increment is defined by the file number of the targeted `FileType.Counter` file and the amount to add up. The file number specifying the file where to credit the amount is given by `FileNo` specified over 5 bits as defined in [Section 6.11](#).

The increment amount is given in `IncrValue` over 4 bytes defined as an unsigned integer.

As listed in [Table 39](#), `IncrementCounterFile` is allowed only if at least one of `FileAR.Write` or `FileAR.ReadWrite` access rights associated with the targeted file is granted.

The communication mode depends on the one from the file being accessed as specified in [Section 6.4.6.6](#). Information on authentication and secure messaging-dependent structure of the command can be found in [Section 6.4](#).

At PICC level, the command is rejected.

### 6.13 Crypto API

The NTAG X DNA supports execution of crypto primitives via the CryptoRequest command. The crypto API enables execution of the following crypto operations:

- Random Number Generation [24][25]
- SHA-256/SHA-384[19]
- ECC Sign/Verify [26]
- ECC Diffie-Hellman [30]
- AES CMAC (128-bit and 256-bit key size) [8]
- AES CBC (128-bit and 256-bit key size) [6][7]
- AES ECB (128-bit and 256-bit key size) [6][7]
- AES CCM (128-bit and 256-bit key size) [28]
- AES GCM (128-bit and 256-bit key size) [29]
- Write to Internal Buffer storage
- HMAC [27]
- HKDF [31]
- Echo

The crypto API provides two internal buffers, which can be used as workspace for RNG data, keys, ECDH output, signature generation/verification and AES encrypt/decrypt. The buffers may be used as 1 or more 16-byte buffers as outlined in Figure 21 and Figure 22. One buffer provides data only retained for the current crypto API session (the transient buffer); the other buffer stores data persistently in NVM (the static buffer).

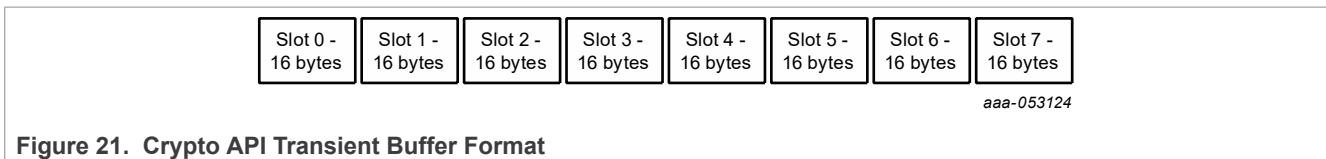

Figure 21. Crypto API Transient Buffer Format

The transient buffer is initialized (all zeroes) on the first Crypto API request following a Cold reset. The transient buffer is reinitialized under the following circumstances.

1. Warm reset,
2. ISO14443-4 Deselect
3. ISO GeneralAuthenticate command
4. AuthenticateEV2First/NonFirst commands
5. Following an update to the Crypto API configuration (option 0x15).

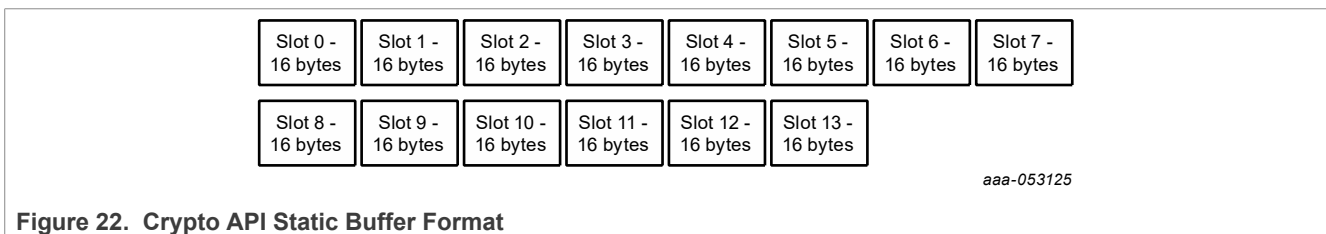

Figure 22. Crypto API Static Buffer Format

The initial state of the static buffer are all zeroes. The contents of the static buffer can be set using the Crypto API functions. The contents of the static buffer are stored securely by ciphering, and integrity protecting the contents when data is written to the buffer. This is done implicitly by NTAG X DNA.

The API permits selection of the input data source and cryptographic keys (if applicable). Keys may be 'crypto API' keys stored statically in the NTAG X DNA or keys stored in a crypto API internal buffer. It is also possible to select the destination for the algorithm result. Input/output destination is selected in accordance with Table 40. If

the number of input or output data bytes exceeds the slot size, then the next slot is used for example, targeting an SHA operation to slot 0 will cause data to be written to both slots 0 and 1.

**Table 40. Crypto API Data Source/Destination Selection**

b7	b6	b5	b4	b3	b2	b1	b0	Description
0	0	0	0	0	0	0	0	Command buffer
1	0	0	0	0	Slot Num			Transient buffer slot number (0 to 7)
1	1	0	0	Slot Num				Static buffer slot number (0 to 15)

The usage of an internal buffer slot can be restricted using a policy option. The policy values are taken from the OS configuration area and are set using the [SetConfiguration](#) command. If no policy is set, then full access is permitted. If a command uses multiple slots, then the policy checks for each slot must be fulfilled.

**Table 41. Crypto API Slot Usage Policy Options**

b7	b6	b5	b4	b3	b2	b1	b0	Description
-	-	-	-	-	-	-	x	Can be used as input data for algorithms specified 0: disabled 1: enabled
-	-	-	-	-	-	x	-	Can be used as a key with algorithms specified 0: disabled 1: enabled

**Table 42. Crypto API Policy Supported Algorithms**

b7	b6	b5	b4	b3	b2	b1	b0	Description
-	-	-	-	-	-	-	x	HMAC 0: disabled 1: enabled
-	-	-	-	-	-	x	-	HKDF 0: disabled 1: enabled
-	-	-	-	-	x	-	-	SHA 0: disabled 1: enabled
-	-	-	-	x	-	-	-	AES 0: disabled 1: enabled
-	-	-	x	-	-	-	-	ECC DSA 0: disabled 1: enabled

The CryptoRequest command format is outlined in [Table 182](#). It requires the command access defined in the configuration. Only a single crypto operation is supported for example, if a multipart SHA operation is initiated and then a request is received to execute an AES operation then the SHA operation shall be aborted.

**Note:** Due to the maximum Lc value being 255, this restricts the maximum amount of input data for each APDU.

If an internal buffer is referenced as input or output, then multiple slots are used for values of more than 16 bytes.

## 6.14 GPIO Management

NTAG X DNA supports two GPIOs:

- GPIO1 may be configured for input detection of a binary-state input signal (e.g. to detect if button is pressed or not), tag tamper detection, binary-state output signal or down-stream power-out.
- GPIO2 may be configured as a binary-state input or output signal (with or without NFC Pause file, see below).

GPIO configuration is done with [SetConfiguration](#) 0x11, see [Section 6.6.3.2](#), and especially [Table 24](#). For each of the modes, dedicated HW aspects as outlined in [Table 26](#) can be set. When configured for down-stream power-out, a targeted voltage/current level needs to be set. It is however possible to overwrite this at runtime via [ManageGPIO](#), if e.g. not sufficient power can be harvested from the actual field strength. When configured as output, the GPIO can also be configured to notify on authentication. This is further detailed in [Section 6.14.5](#).

The [ReadGPIO](#) command, as defined in [Section 7.11.2](#), may be used to read the current status of the GPIOs. The [ManageGPIO](#), as defined in [Section 7.11.1](#), is used for controlling the output on GPIO1.

In addition to supporting external device notification, the [ManageGPIO](#) may be used to retrieve information from an external MCU via the 'NFC Pause' option, see [Section 6.14.1](#).

### 6.14.1 NFC Pause feature

The NFC Pause feature allows to transfer control from an NFC Host to an MCU controlling NTAG X DNA as a master via the I2C interface.

Two ways to activate an NFC Pause are supported:

- [ManageGPIO](#) can trigger the NFC Pause via its parameters. This option is possible for any GPIO that is configured for output, including GPIO2 if configured with [NFCPauseFile](#), see [SetConfiguration](#) 0x11. This flow is outlined in [Figure 23](#). In this case, the GPIO output signal is also explicitly controlled through the issued [ManageGPIO](#).
- [ISOReadBinary/ReadData](#) can implicitly trigger the NFC Pause when targeting the file that is configured for NFC Pause. This allows to use the feature in the context of an NFC Forum Type4Tag [15], as outlined in [Figure 24](#). This option is only available for GPIO2, as explicitly configured with [SetConfiguration](#) 0x11. In this case, the GPIO2 output is automatically toggled. NTAG X DNA supports configuring a single file together with a start and end offset. The NFC Pause will only be triggered if any data within those offsets is read, i.e.  $NFCPauseOffset < (ReadOffset + ReadLength)$  and  $NFCPauseOffset + NFCPauseLength > ReadOffset$ . In a Type4Tag context, this allows e.g. triggering the NFC Pause only when reading NDEF length (to allow dynamic NDEF length being returned) or only when reading the actual content, avoiding multiple switches to the MCU.

When NFC Pause is triggered, NTAG X DNA shall halt processing on the NFC interface (only sending WTx requests) until the [ManageGPIO](#) is received on the I2C interface to indicate restart of NFC processing, i.e. releasing the NFC Pause.

Until the NFC Pause Release, the MCU can send any command over the I2C interface. When NFC Pause is triggered by [ISOReadBinary/ReadData](#), this will typically include updating the targeted file content through [ISOUpdateBinary/WriteData](#). As the GPIO only provides a binary signal, the MCU does not know what command triggered the NFC Pause, and in case of a read command what offset and length are requested.

When NFC Pause is released, NTAG X DNA behavior depends on how the NFC Pause was triggered. If triggered by [ManageGPIO](#), NTAG X DNA shall use the [NFCPauseRespData](#) provided over the I2C interface in the release command as the response data provided on the NFC interface. The size of this data is limited up to 239 bytes. If the NFC Pause was triggered by [ISOReadBinary/ReadData](#), NTAG X DNA ignores the

[NFCPauseRespData](#) (if any), and retrieve the NFC response data by further processing the received read command (i.e. from the targeted file).

On NFC Pause, the application selection state is transferred from the NFC interface to the I2C interface. Therefore, there is no need to reselect the targeted application over I2C. Potential uncommitted write operations from the NFC interface can be committed over I2C. The authentication state is not transferred, i.e. over I2C one starts in [VCState.NotAuthenticated](#). If a new authentication is initiated over I2C.

On NFC Pause Release, the same is true: application selection state is transferred from the I2C interface to the NFC interface. The original authentication state from before the NFC pause is still active over the NFC interface, except if a new authentication was initiated over I2C. Then the NFC interface also starts again in [VCState.NotAuthenticated](#).

This means NTAG X DNA can only maintain a single authentication session, giving the following options:

- if triggered by [ISOReadBinary](#): as there is then no authentication over the NFC interface, authentication over I2C is possible, and may be required for e.g. executing [WriteData](#).
- if triggered by [ReadData](#): depending on the targeted file's access conditions, an authentication over NFC interface may be required. If required, one must not require an authentication for [WriteData](#) over I2C, i.e. [FileAR.Write](#) or [FileAR.ReadWrite](#) shall typically be set to 0xD allowing free access over I2C. If an authentication is initiated over I2C, the NFC authentication shall be lost. Therefore, after transferring the control back to NFC, the [ReadData](#) may fail, returning an error, as access control checks are done again this stage. Note that when the communication mode changed during the NFC Pause this updated mode is immediately applied on the response.
- if triggered by [ManageGPIO](#): depending on the [ManageGPIOAccessCondition](#), an authentication may be required. If authenticated over the NFC interface, and an authentication is initiated over I2C, the NFC authentication shall be lost. Similar as above, after transferring the control back to NFC, the [ManageGPIO](#) may fail, returning an error, as access control checks are done again this stage.

Note that [Figure 23](#) is only one possible example. More complex flows are also possible. For example, one could set the GPIO to HIGH on a first [ManageGPIO](#) without pausing the NFC. This could trigger the Master MCU to start its processing (e.g. interrogating an I2C slave sensor), while in parallel on the NFC interface with NTAG X DNA, the NFC host can still further exchange commands to read or updates some files. Once the NFC host is done, it can send another [ManageGPIO](#) setting the GPIO back to LOW while pausing the NFC. This then triggers the Master MCU that it can return its data over the NFC interface.

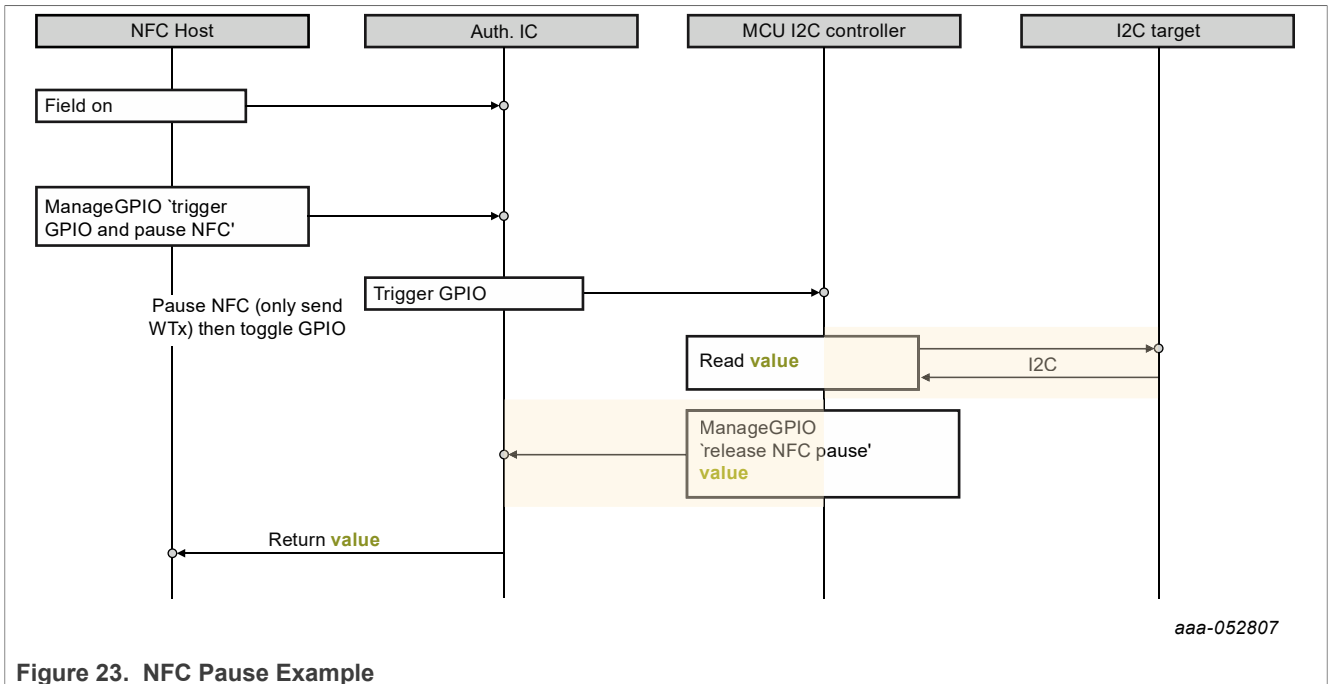

Figure 23. NFC Pause Example

The [Figure 24](#) gives a further example where the NFC Pause is triggered by an [ISOReadBinary](#). Note that the figure still shows a simplified flow, as a Type4Tag is typically read in multiple stages (first reading the CC file and NDEF length)[\[15\]](#).

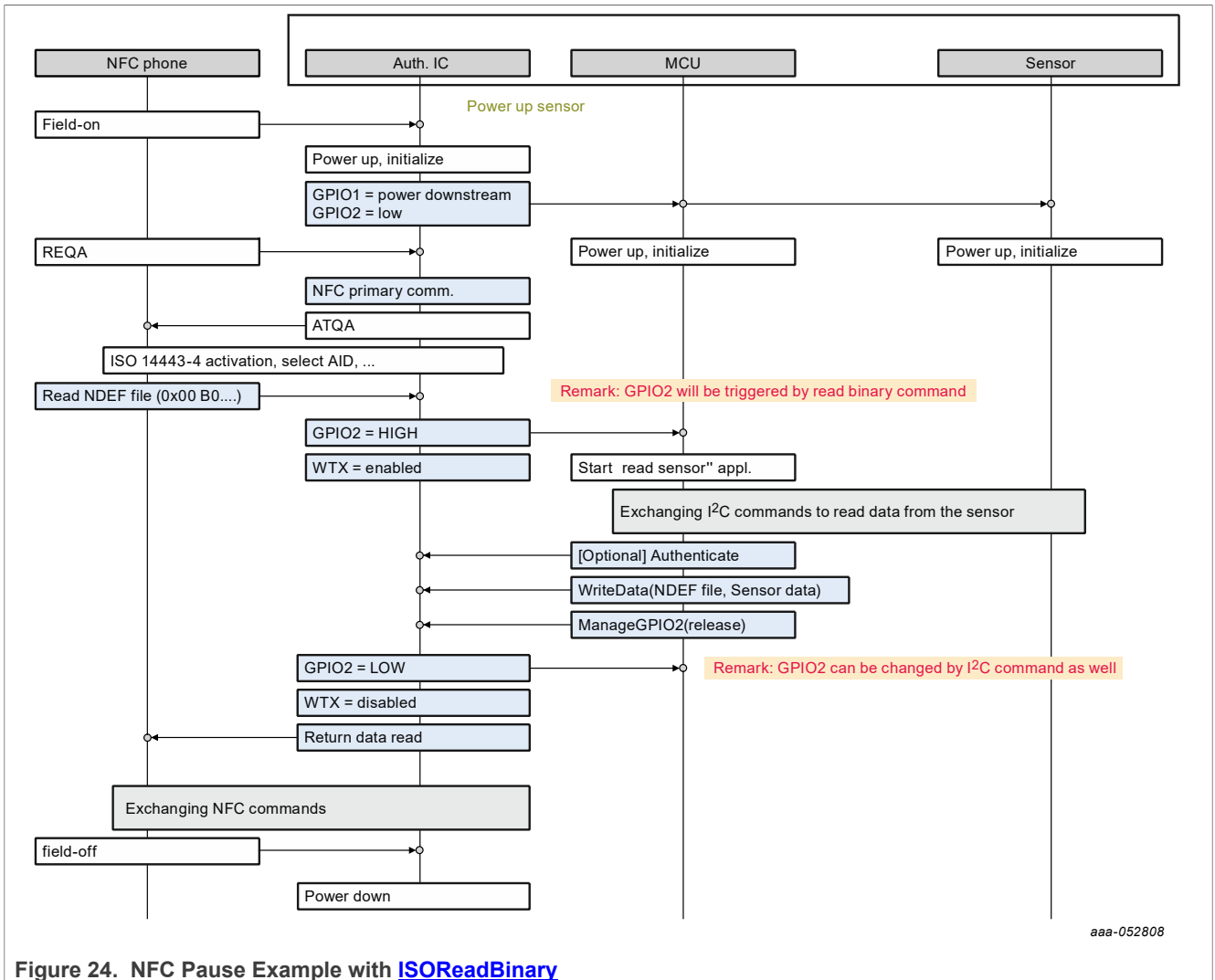

Figure 24. NFC Pause Example with [ISOReadBinary](#)

### 6.14.2 Command ManageGPIO

The [ManageGPIO](#) command format is outlined in [Section 6.14](#).

The command is only accepted at application level, and will be rejected at PICC level. Depending on the [ManageGPIOAccessCondition](#), as configured with [SetConfiguration](#) Option 0x11, the command may require an authentication and the configured secure messaging communication mode. By default, the command is disabled.

The Release NFC Pause action shall only be accepted over the I2C interface and does not require authentication independently of the configured access condition.

When a GPIO is configured for output, after a power-on reset, the GPIO will be initialized with the state as configured by the [GPIOXConfig](#) from [SetConfiguration](#) Option 0x11 on the first command after activation, i.e. ISO/IEC14443-4 or I<sup>2</sup>C activation. This is independently of the state from a previous activation. Immediately after the PoR, output GPIOs will be in high-impedance (High-Z) state.

Similar, when GPIO1 is configured for down-stream power out, after a power-on reset, the feature will always be disabled by having the pin in high-impedance (High-Z) state, independently of the state from a previous activation. By default, when enabling down-stream power out via the SET operation, the voltage/current level as configured with [SetConfiguration](#) Option 0x11 will be targeted. It is also possible to give a different target at

runtime via [ManageGPIO](#). This allows reacting on a [Resp.WEAK\\_FIELD](#) response. If only a targeted voltage level is given, the measured current will also be returned. Alternatively, as long as power harvesting was not enabled, one could execute a MEASURE operation. If combined with CLEAR, power harvesting is kept disabled, i.e. only a measurement is done. If combined with SET, this enables down-stream power out at the same time, e.g. to already start harvesting with a conservative target. Potentially, one can then later increase the targeted power by a further [ManageGPIO](#) SET operation based on the received measurement. Note that once down-stream power out has been enabled, a further MEASURE operation will be rejected. If enabling power harvesting, the targeted power will be limited according to the in rush current limitation and duration configured with [SetConfiguration](#) > Option 0x11. It is also possible to reserve part of the available RF Power for NTAG X DNA via the AdditionalCurrent configuration. When executing a [ManageGPIO](#) SET or MEASURE operation, or the combination of both, NTAG X DNA always returns a WTX over the NFC interface, before executing the operation.

**6.14.3 Command ReadGPIO**

The [ReadGPIO](#), as defined in [Section 7.8.2](#), returns the status of GPIO1 and/or GPIO2 for both input and output use cases, as configured with [SetConfiguration](#) Option 0x11, see [Section 6.6.3.2](#).

This includes GPIO1 configuration for tag tamper detection. In case of tag tamper detection, a permanent and current status are distinguished, as defined in [Section 6.15.1](#).

If GPIO1 is configured for tag tamper detection (GPIO1Mode = 0x03), a Tag Tamper measurement as defined in [Section 6.15.1](#) will be triggered. If detected as open, the [TTPermStatus](#) will be updated to Open.

For GPIO input configurations (GPIOXMode = 0x01), only the current status for GPIO1 and GPIO2 are returned: [GPIO1CurrStatus](#) and [GPIO2CurrStatus](#). This is the value as measured during the execution of the [ReadGPIO](#) command.

For GPIO output (GPIOXMode = 0x02 or GPIO2Mode = 0x05) and down-stream power out (GPIO1Mode = 0x04) operations, the current status can be retrieved, i.e. whether or not the output or down-stream power out has been set or not. This allows an external host to keep track.

For both input and output cases, [GPIO1CurrStatus](#) and [GPIO2CurrStatus](#) can take the following values:

- *Low*: 0x4C, i.e. ASCII encoding of 'L'. This is the value for a logical '0', e.g. if the button is not pressed. In case of output, the output is not driven, or down-stream power out is not enabled (e.g. after CLEAR operation with [ManageGPIO](#)).
- *High*: 0x48, i.e. ASCII encoding of 'H'. This is the value for a logical '1', e.g. if the button is pressed. In case of output, the output is driven or down-stream power out is enabled (e.g. after SET operation with [ManageGPIO](#)).

**Note:** All output cases for a GPIO pin configuration are covered in a single row in the table below. The following value is returned if the GPIO pin is disabled, or the feature is not enabled yet:

- *Invalid*: 0x49, i.e. ASCII encoding of 'I'. This is the value when the feature has not been enabled. The complete GPIO status is returned on 3 bytes:
- Byte[0]: [TTPermStatus](#) or N/A
- Byte[1]: [TTCurrStatus](#), [GPIO1CurrStatus](#) or N/A
- Byte[2]: [GPIO2CurrStatus](#) or N/A

This results in the following possible outputs, depending on the GPIO configuration:

Table 43. [ReadGPIO](#) response

Configuration		Response data		
GPIO1Conf	GPIO2Conf	GPIOByte0	GPIOByte1	GPIOByte2
Input	Input Output	N/A	<a href="#">GPIO1CurrStatus</a>	<a href="#">GPIO2CurrStatus</a>

Table 43. [ReadGPIO](#) response...continued

	Other	=('I')	=('H'/'L')	=('H'/'L')
		N/A =('I')	<a href="#">GPIO1CurrStatus</a> =('H'/'L')	GPIO2CurrStatus =('H'/'L')
		N/A =('I')	<a href="#">GPIO1CurrStatus</a> =('H'/'L')	N/A =('I')
TT	Input Output Other	<a href="#">TTPermStatus</a> =('C'/'O')	<a href="#">TTCurrStatus</a> =('C'/'O')	GPIO2CurrStatus =('H'/'L')
		<a href="#">TTPermStatus</a> =('C'/'O')	<a href="#">TTCurrStatus</a> =('C'/'O')	GPIO2CurrStatus =('H'/'L')
		<a href="#">TTPermStatus</a> =('C'/'O')	<a href="#">TTCurrStatus</a> =('C'/'O')	N/A =('I')
Output	Input Output Other	N/A =('I')	<a href="#">GPIO1CurrStatus</a> =('H'/'L')	GPIO2CurrStatus =('H'/'L')
		N/A =('I')	<a href="#">GPIO1CurrStatus</a> =('H'/'L')	GPIO2CurrStatus =('H'/'L')
		N/A =('I')	<a href="#">GPIO1CurrStatus</a> =('H'/'L')	N/A =('I')
Other	Input Output Other	N/A =('I')	N/A =('I')	GPIO2CurrStatus =('H'/'L')
		N/A =('I')	N/A =('I')	GPIO2CurrStatus =('H'/'L')
		N/A =('I')	N/A =('I')	N/A =('I')

The command is only accepted at application level, and will be rejected at PICC level. Depending on the [ReadGPIOAccessCondition](#), as configured with [SetConfiguration](#) Option0x11, the command may require an authentication and specific secure messaging communication mode. By default, the command is disabled.

#### 6.14.4 Mirroring in the NDEF message

The GPIO Input and Tag Tamper statuses can be mirrored together within the NDEF messaging. In this way, the status can be protected by the Secure Dynamic Messaging, as defined in [Section 6.4.8](#) and more specifically [Section 6.4.8.5](#).

If mirroring is enabled, the encoding within the NDEF file will be identical to the 3-byte [ReadGPIO](#) response, see [Table 259](#). Note that only Input and Tag Tamper configurations are mirrored. Output configurations are interpreted as 'Other' for NDEF mirroring, i.e. returning 'I' for Invalid.

To enable this mirroring, the configuration must be done with [ChangeFileSettings](#), see [Section 7.8.7](#).

#### 6.14.5 Authentication notification

When configured as output, the GPIO can be configured to notify on authentication. This configuration is also done via [SetConfiguration](#) 0x11 using the *GPIO1Notif* and *GPIO2Notif* parameter.

When configured, the targeted GPIO is enabled (i.e. set to HIGH representing logical '1') once the authenticated state is reached. This means:

- On successful execution of SIGMA-I mutual authentication; see [Section 6.4.2](#), i.e. [ISOGeneralAuthenticate](#) replying with message type 0xB4 when acting as responder or 0xA1 when acting as initiator.
- On successful execution of symmetric mutual authentication with [AuthenticateEV2NonFirstPart2](#).

Note that it is still possible to manually toggle the GPIO with [ManageGPIO](#) (potentially even triggering an NFC Pause) if authentication notification is enabled. Most likely, this kind of double usage of a GPIO pin should be avoided for a use case, as can e.g. be done by configuring the *ManageGPIOAccessCondition* to 0xF.

When losing the authentication state, the GPIO will be disabled (i.e. set to LOW representing logical '0'). See [Section 6.17.1.3](#) and [Section 6.4.3.4](#) for the different reasons to lose authentication.

#### 6.14.6 NFC field notification

When configured as output, the GPIO can be configured to notify on NFC field presence. This configuration is also done via [SetConfiguration](#) 0x11 using the *GPIO1Notif* and *GPIO2Notif* parameter.

When configured, the targeted GPIO is enabled (i.e. set to HIGH representing logical '1') once the NTAG X DNA detects an NFC field.

The GPIO level is updated by the NFC *ISOSelectFile* command after selecting NDEF application. The NFC field notification is not realized by a hardware but a software mechanism.

When NTAG X DNA is removed from the NFC field, this has no effect on the GPIO notification. It is assumed that an external MCU acts on the enabling of the GPIO pin by either halting the ongoing I2C session. In this case, a reset cycle would clear the GPIO pin, reenabling communication interface arbitration. In case the MCU ignores the GPIO2 signal, it must be understood that it remains set until e.g. manually cleared with [ManageGPIO](#).

### 6.15 Tag Tamper Protection

NTAG X DNA offers an NFC Forum-compliant solution to reflect e.g. if the sealing of a product is opened. This solution works without a dedicated application on a cell phone. It only requires the capability of reading out NFC Forum Type 4 Tag [\[15\]](#). NTAG X DNA contains four pads, where two are used for antenna connection and the other two will connect a detection wire as illustrated in [Figure 25](#). During the execution of the first command that is sent after ISO/IEC 14443-4 activation, the IC checks the tag tamper wire. If opened, this status will be recorded as permanent status in NVM. The result can be reflected in the NDEF message. Next to this, NTAG X DNA also supports a specific command that triggers a measurement and returns both the permanent and

current status. This chapter describes how the feature is enabled, when the check is executed and how the status can be retrieved.

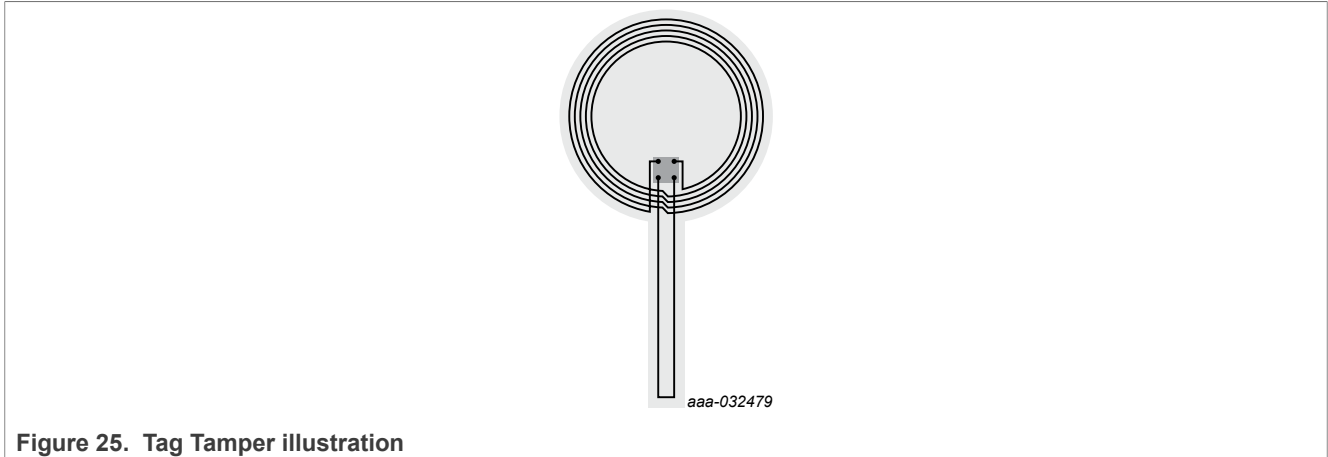

Figure 25. Tag Tamper illustration

### 6.15.1 Enabling the Tag Tamper feature

At delivery, NTAG X DNA has the tag tamper feature disabled. The feature can be enabled by [SetConfiguration](#) with Option 0x11, see [Section 7.4.2](#). Once enabled, the NTAG X DNA starts Tag Tamper measurements, see [Section 6.15.2](#) from the next activation onwards. Before, once enabled, a measurement can already immediately be triggered with [ReadGPIO](#).

With [SetConfiguration](#), when enabling the feature, one can at the same time configure the communication mode and access right related with [ReadGPIO](#) for Tag Tamper Status retrieval, see [Section 6.14.3](#).

### 6.15.2 Tag Tamper Measurements

NTAG X DNA maintains a permanent Tag Tamper status `TTPermStatus`. The `TTPermStatus` and the current status `TTCurrStatus` can be mirrored together in the NDEF file, and included in the Secure Dynamic Messaging, see [Section 6.4.8](#). Both statuses can also be retrieved with [ReadGPIO](#). The following values are supported:

- *Close*: 0x43, i.e. ASCII encoding of 'C'. This is the initial value when the seal is still closed.
- *Open*: 0x4F, i.e. ASCII encoding of 'O'. This is the value when the seal was opened.
- *Invalid*: 0x49, i.e. ASCII encoding of 'I'. This is the value when the feature has not been enabled yet and no measurements are executed.

Once the feature has been enabled, NTAG X DNA measures whether the seal is opened by applying a measurement on the detection wire. As the NTAG X DNA is a passive tag, it cannot trigger measurements itself. The measurement will be done, each time the tag is powered and booted, but to not affect potential time critical processing during booting and activation, the measurement will only be done during processing of the first ISO/IEC 14443-4 command after complete activation, if the current `TTPermStatus` is still set to Close. This means on the first application specific command after RATS and eventually PPS, see [\[4\]](#).

If a measurement detects the seal to be opened, the `TTPermStatus` is updated to Open. Once set to Open, the measurement on boot will not be triggered anymore. The `TTPermStatus` cannot be reset to Close anymore. So even if an attacker manages to fix the opened seal, this will not be reflected by `TTPermStatus` if once a measurement was made while the seal was opened.

The following commands also trigger a measurement once the feature is enabled:

- [ReadGPIO](#) see [Section 6.14.3](#).
- [ReadData](#) and [ISOReadBinary](#), if required for the Secure Dynamic Messaging and Mirroring, see [Section 6.4.8.5](#).

Note that how often a measurement is made thus depends on how often the device will be activated and used. Note that there remains a residual risk of opening and fixing a seal in between measurements going unnoticed. The assessment on how big this residual risk is, is out of scope of this document.

### 6.15.3 Tag Tamper status retrieval

#### 6.15.3.1 Mirroring in the NDEF message

The TTPermStatus and the TTCurrStatus can be mirrored within the NDEF messaging. In this way, the status can be protected by the Secure Dynamic Messaging, as defined in [Section 6.4.8](#) and more specifically [Section 6.4.8.5](#). To enable this mirroring, the configuration needs to be done with [ChangeFileSettings](#), see [Section 7.8.7](#).

#### 6.15.3.2 ReadGPIO

NTAG X DNA supports retrieving of the permanent and current Tag Tamper Status ([TTPermStatus](#) and [TTCurrStatus](#)) with [ReadGPIO](#). This is defined in [Section 6.14.3](#).

## 6.16 Timer Support

The NTAG X DNA supports three timers:

- Authority Watchdog Timer 1 (AWDT1)
- Authority Watchdog Timer 2 (AWDT2)
- Halt Watchdog Timer (HWDT)

The timer values are configured using [SetConfiguration](#) Option 0x14 as defined in [Section 6.6.3.2](#).

### 6.16.1 Authority Watchdog Timers

The AWDT1 timer is used to limit the time the host has to execute mutual authentication. If configured it is used when performing AES-based symmetric mutual authentication or SIGMA-I asymmetric mutual authentication.

When performing SIGMA-I as the Initiator the AWDT1 timer is started when the NTAG X DNA sends its ephemeral public key to the host. It is stopped when the host provides its ephemeral public key and session signature or the session is explicitly aborted e.g. a new mutual auth session is started.

When performing AES-based mutual authentication the AWDT1 timer is started when the NTAG X DNA receives the first [AuthenticateEV2First](#) command. It is stopped when the hosts sends the final [AuthenticateEV2First](#) command or the session is explicitly aborted e.g. a new mutual auth session is started.

If the AWDT1 timer expires then the NTAG X DNA closes the current mutual authentication session, and reject the next command received.

The AWDT2 timer is used to limit the period of the secure tunnel opened by a successful mutual authentication. The AWDT2 timer is started when the NTAG X DNA authenticates the host and completes mutual authentication. When the AWDT2 timer expires the NTAG X DNA closes the current secure tunnel session.

### 6.16.2 Halt Watchdog Timer

The HWDT is used to move the NTAG X DNA to the HALT state to save power when there is no I/O activity. The HWDT timer is only enabled when the device is Vcc powered. The timer is reset (not stopped) when a command is received on either the I<sup>2</sup>C or the NFC interface. If the timer expires the device shall transition to the low power HALT state; resulting in termination of any ongoing activity e.g. an open authentication session.

The HALT state is exited when one of the following events occurs:

- I<sup>2</sup>C activity (SDA pulled low).
- Receipt of a WUPA command via the NFC interface.

It is also possible for the host to explicitly trigger a transition to the HALT state by sending the ISO14443 HLT command on the NFC interface.

## 6.17 ISO/IEC 7816-4 Support

NTAG X DNA supports ISO/IEC 7816-4 commands [5] by wrapping into ISO/IEC 7816-4 APDUs of the native command set, as explained in [Section 6.3.2](#).

On top, the following standard ISO/IEC 7816-4 commands are supported as well:

- [ISOSelectFile](#) with INS code 0xA4
- [ISOReadBinary](#) with INS code 0xB0
- [ISOUpdateBinary](#) with INS code 0xD6

### 6.17.1 Standard ISO/IEC 7816-4 commands

NTAG X DNA supports a selection of standard ISO/IEC 7816-4 commands, i.e. commands from the interindustry class [5]. These commands are defined in this section. First the authentication and secure messaging aspects of these commands are described.

#### 6.17.1.1 Byte order

For all parameters of standard ISO/IEC 7816-4 commands, the representation on the interface is most significant byte (MSB) first notation. As data like the 2-byte ISO/IEC 7816-4 file identifiers, are in different order on the native command interface, this needs to be especially taken into account.

#### 6.17.1.2 Security concepts of standard ISO/IEC 7816-4 commands

Standard ISO/IEC 7816-4 commands for data management are mainly supported to allow NFC Forum Type 4 Tag use cases [15].

These commands do not support secure messaging, and therefore can only be issued under following conditions:

- [ISOReadBinary](#): if targeted file is configured with at least one of [FileAR.Read](#), [FileAR.ReadWrite](#), [FileAR.SDMFileRead](#) to 0xE, i.e. free access, and issuing the command in [VCState.NotAuthenticated](#). Depending on the configuration Secure Dynamic Messaging, see [Section 6.4.8](#), is applied.
- [ISOUpdateBinary](#): if targeted file is configured with at least one of [FileAR.Write](#) and [FileAR.ReadWrite](#) to 0xE, i.e. free access, and issuing the command in [VCState.NotAuthenticated](#).

### 6.17.1.3 Error Handling

In case of unsuccessful command execution, NTAG X DNA sends a return code different from [Resp.ISO9000](#). The full list of ISO/IEC 7816-4 errors is given in [Section 7.1](#).

In case of unsuccessful command execution, NTAG X DNA executes the same abort actions as for native commands, see [Section 6.17.1.3](#).

The following generic error cases can occur:

- [Resp.ISO6985](#): An ongoing wrapped chained command or multiple pass command is aborted, see [Section 6.3.3](#).
- [Resp.ISO6700](#): Wrong or inconsistent APDU length according to [\[5\]](#).
- [Resp.ISO6E00](#): Unsupported CLA byte.
- [Resp.ISO6D00](#): The received instruction code *INS* is not supported.
- [Resp.ISO6A86](#): Incorrect parameters *P1* or *P2*.

### 6.17.1.4 ISOSelectFile

[ISOSelectFile](#) as defined in compliance with ISO/IEC7816-4 in [Table 261](#) selects either the PICC level, an application, or a file within the application.

[P1](#) defines the selection method.

If *P1* is set to 0x00, 0x01, or 0x02, selection is done by a 2-byte ISO file identifier. *P1* set to 0x00 is used to select the MF (i.e. the PICC level), a DF (i.e. an application if currently the PICC level is selected) or an EF (i.e. a file within the currently selected application). *P1* set to 0x01 is used to select a DF, if the MF is currently selected. *P1* set to 0x02 can be used to select an EF, if an application is currently selected. For MF selection, 0x3F00 or empty data is to be used. For DF and EF selection, [Data](#) shall hold the 2-byte ISO/IEC 7816-4 file identifier.

**Note:** *The different byte order for the file identifiers when written with native commands and when used here for ISO/IEC 7816-4 selection.*

If *P1* is set to 0x03, the MF level is selected. This option can only be issued if currently an application (DF) is selected. In this case, [Data](#) must be empty.

If *P1* is set to 0x04, selection is done by DF name which can be up to 16 bytes.

The registered ISO DF name is 0xD2760000850100. When selecting this DF name, the PICC level (or MF) is selected.

For selecting the application immediately, the ISO/IEC 7816-4 DF name 0xD2760000850101 is to be used.

[P2](#) indicates whether or not File Control Information (FCI) is to be returned in case of application selection.

If this is to be returned, *P2* is set to 0x00. In this case, FCI is returned as response data, if the following conditions are satisfied:

- the targeted application hold as file with native file number 0x1F.
- this file is of [FileType.StandardData](#).
- this file is freely accessible, i.e. [FileAR.Read](#) or [FileAR.ReadWrite](#) holds the free access condition, see [Section 6.11.2](#).
- [Le](#) is present.

The number of bytes requested by [Le](#) up to the complete file data will be returned in plain. There is no specific FCI template format checked, i.e. the data stored in the file will be sent back as is. In case of PICC level or file selection, FCI data is never returned.

In case of failure, the current selection status both at application (MF/DF) and file (EF) level is not affected. The currently selected application and file, if any, remains selected.

### 6.17.1.5 [ISOReadBinary](#)

[ISOReadBinary](#) as defined in compliance with ISO/IEC7816-4 in [Table 265](#) can be used to read data from [FileType.StandardData](#) files.

[P1](#) and [P2](#) define the targeted file and the offset.

If Bit 7 of [P1](#) is set, then [P1](#) Bit4-0 encodes a short ISO/IEC 7816-4 file identifier, i.e. referencing the five least significant bits of the 2-byte ISO/IEC 7816-4 file identifiers. All zero bits is reserved for referencing the currently selected file. All one bits is reserved [\[5\]](#) and will be rejected. The referenced file will be selected for this and subsequent operations. Note that if intending to use short file identifiers, the user must take care of avoiding collisions amongst each other and with the reserved values in the definition of the file system, as there is no checking on file creation. [P2](#) encodes the offset from 0 byte to 255 byte.

If Bit 7 of [P1](#) is not set, then [P1](#) Bit6-0 concatenated with [P2](#) encode the offset from 0 to 32767 byte. The file currently selected is targeted. If no file was selected, the command is rejected. At PICC level, the command is rejected.

[Lc](#) encodes the number of bytes to be returned. If the encoded value is 0x00 or if it is larger than the number of bytes in the file (starting from the offset), all remaining bytes of the file will be returned.

As listed in [Table 39](#), [ISOReadBinary](#) is allowed only if at least one of [FileAR.Read](#), [FileAR.ReadWrite](#) and [FileAR.SDMFileRead](#) access rights associated with the targeted file is granted. It must be set to 0xE, i.e. free access, as the command is only accepted in [VCState.NotAuthenticated](#), i.e. not supporting EV2 secure messaging.

Only Secure Dynamic Messaging is supported (which does not require a preceding authentication), depending on the targeted file's configuration, see [Section 6.4.8](#).

The [ISOReadBinary](#) can be used to implicitly trigger an NFC Pause, as explained in [Section 6.14.1](#).

### 6.17.1.6 [ISOUpdateBinary](#)

[ISOUpdateBinary](#) as defined in compliance with ISO/IEC7816-4 in [Table 269](#) can be used to write data to [FileType.StandardData](#) files.

[P1](#) and [P2](#) define the targeted file and the offset. The interpretation is identical as for [ISOReadBinary](#), see [Section 7.12.3](#).

At PICC level, the command is rejected.

[Lc](#) encodes the number of bytes to be written. The command is rejected if one attempts to write across the file boundary.

The [FileType.StandardData](#) does offer limited anti-tearing protection, see [Section 6.11.1.1](#).

As listed in [Table 39](#), [ISOUpdateBinary](#) is allowed only if at least one of [FileAR.Write](#) and [FileAR.ReadWrite](#) access rights associated with the targeted file is granted. It must be set to 0xE, i.e. free access, as the command is only accepted in [VCState.NotAuthenticated](#), i.e. not supporting EV2 secure messaging.

## 6.18 Trust Provisioning

### 6.18.1 Originality Check Key Pair and Certificate

During manufacturing, NTAG X DNA is trust-provisioned with an ECC-based key pair and related certificate to allow verification of the genuineness of the IC. The originality check is done by executing a card-unilateral authentication through a challenge-response protocol. As the protocol creates a trace that potentially cannot be repudiated, the key pair is shared by all ICs in one production batch to reduce the privacy implications. On top, the feature can be disabled through [SetConfiguration](#) Option 0x0E.

#### 6.18.1.1 Originality Key Pair

The Originality Check key pair (Priv.Orig, Pub.Orig) is trust-provisioned with the following properties. For KeyPolicy and Read/WriteAccess encoding, refer to [ManageKeyPair](#) API definition.

- Shared key pair per batch.
- Priv.Orig is stored as [ECCPrivateKey](#) KeyNo 0x01 at the PICC level, with following default configuration:
  - NIST P-256
  - KeyPolicy: 0x0100, only allowing ECC-based Unilateral Authentication.
  - WriteAccess: 0x30. For NTAG X DNA, this access right is irrelevant as NTAG X DNA does not support reader authentication at the PICC level.
  - KUCLimit: disabled
- Pub.Orig is trusted via the certificate Cert.Orig, as specified in [Section 6.18.1.2](#).

#### 6.18.1.2 Originality Certificate

The Originality Check certificate is stored in a [FileType.StandardData](#) file, as introduced in [Section 6.11.1.1](#), at the PICC level.

It can be freely read upfront the authentication using the supported data management (see [Section 6.12.1](#)) and standard ISO/IEC 7816-4 commands (see [Section 6.17.1](#)) for data file access. Access to the file can be disabled by enabling the enhanced privacy feature, see [SetConfiguration](#).

The file holding the certificate is a [FileType.StandardData](#) file of 384 bytes with the following properties:

- FileNo = 0x01; ISO File ID = 0xEF01
- [FileAR.Read](#) = 0xE; [FileAR.Write](#) = 0x0; [FileAR.ReadWrite](#) = 0x0; [FileAR.Change](#) = 0x0. For NTAG X DNA, only [FileAR.Read](#) is relevant, as one cannot authenticate at the PICC -level.

This file holds the NXP Originality Certificate Cert.Orig. If needed, the file content is further padded with all zero bytes.

The NXP Originality Certificate is signed by NXP Trust Provisioning using a dedicated CA key pair for this product. The CA key pair can be retrieved from <https://www.gp-ca.nxp.com/CA/getCA?caid=63709320110003> filling in the CAID with the serialNumber encoded in the issuer name.

The NXP Originality Certificate certificate is a public-key certificate according to X.509 v3 format [\[32\]](#). Optional fields from [\[32\]](#) have been omitted, that is, the certificate will not contain additional issuerUniqueID, subjectUniqueID, and extensions. The signature algorithm used is ECDSA with SHA-256.

The issuer is set to the following content:

- Organizational name (O, OID 2.5.4.10): “NXP”
- Common name (CN, OID 2.5.4.3): “NXP Orig RootCAvE2xx” with xx varying per product variant
- SerialNumber (OID 2.5.4.5): 14 digits encoding CAID

The subject contains a subset of [GetVersion](#): VendorID || HWMajorVersion || HWMinorVersion || SWType || SWSubType || SWMajorVersion || SWMinorVersion. This is encoded in a description (OID 2.5.4.13)[\[32\]](#), using hexadecimal ASCII encoding.

### 6.18.1.3 Card-unilateral authentication

The authentication supported by Priv.Orig is outlined in [Section 6.4.3](#).

## 6.18.2 Application Key Pair and Certificate

At application-level, in the default configuration, NTAG X DNA is trust-provisioned during manufacturing with an App-level key pair (Priv.App, Pub.App) and related certificate Cert.App. This can be used to authenticate individual devices for executing App-level functionality.

### 6.18.2.1 Application Key Pair

The application key pair (Priv.App, Pub.App) is a unique key pair per die from which the Priv.App is stored as [ECCPrivateKey](#) KeyNo 0x00 within the application, holding with following default configuration:

- NIST P-256
- KeyPolicy: 0x0004, only allowing SIGMA-I Mutual Authentication. Note that by default both Prover and Verifier mode are enabled. For privacy (non-traceability), only Prover may be preferred, with requires configuration per interface (NFC/I2C) via [SetConfiguration](#) Option 0x0F/0x10.
- WriteAccess: 0x30, allowing replacement with [ManageKeyPair](#) after an authentication granting [AppMasterKey](#) access rights in [CommMode.Full](#).
- KUCLimit: disabled.

For KeyPolicy and WriteAccess encoding, refer also to [ManageKeyPair](#) API definition.

Pub.App is trusted via the certificate Cert.App, as specified in the next subsection.

### 6.18.2.2 Application Certificate

The Cert.App is stored as an uncompressed end-leaf certificate without parent certificates within a certificate repository, see [Section 6.9.1](#), with id 0x00, with following default configuration:

- Associated with the [ECCPrivateKey](#) with KeyNo 0x00.
- Repository size: [TBD]
- WriteAccess: 0x30, allowing [ManageCertRepo](#) after an authentication granting [AppMasterKey](#) access rights in [CommMode.Full](#).
- ReadAccess: 0x30, allowing [ReadCertRepo](#) after an authentication granting [AppMasterKey](#) access rights in [CommMode.Full](#). Note that typically the certificate is only to be retrieved via the SIGMA-I authentication itself. Though if needed this configuration can be changed, requiring the certificate to be re-loaded.
- No mapping table, this means the certificate is stored as a plain X.509 certificate without any PKCS#7 wrapping.

The certificate repository is already activated and thus ready for use with the SIGMA-I authentication.

The Cert.App is signed by NXP Trust Provisioning using a dedicated key pair. The CA key pair can be retrieved from <https://www.gp-ca.nxp.com/CA/getCA?caid=63709320101003> filling in the CAID with the serialNumber encoded in the issuer name.

The Cert.App is a public-key certificate according to X.509 v3 format [11]. It has the same structure as the Cert.Orig defined in [subsection 17.1.2](#) with the following content.

The issuer is set to:

- Organizational name (O, OID 2.5.4.10): “NXP”
- Common name (CN, OID 2.5.4.3): “NXP Auth RootCAvE2xx” with xx varying per product variant
- SerialNumber (OID 2.5.4.5): 14 digits encoding CAID

The subject is set to:

- Description (OID 2.5.4.13), containing a subset of [GetVersion](#): VendorID || HWMajorVersion || HWMinorVersion || SWType || SWSubType || SWMajorVersion || SWMinorVersion, using hexadecimal ASCII encoding.
- UniqueIdentifier (OID 2.5.4.45) with 7-byte UID as a BIT STRING

### 6.18.3 Commercial customization options

NXP provides commercial customization options for trust-provisioning. This allows for a customer-dedicated delivery configuration.

This may include the provisioning of a customer-specific [CARootKey](#). This allows to do the initial personalization with the ECC-based SIGMA-I authentication. By this, the need for a secure environment can be removed, compared to when doing the initial personalization based on the default AES keys.

Additionally, also customer-specific AES keys, certificates and/or a customized file system and configuration can be provisioned. Reach out to your local sales representative for more information.

## 6.19 Security

### 6.19.1 Introduction

NXP Semiconductors has gained comprehensive security experience from developing more than six generations of certified secure microcontrollers and other security certified products.

The large number of approved features and the significant enhancements over the different generations of certified secure products and secure microcontrollers are the foundation of the security concept that is implemented in the NTAG X DNA product. These mentioned design features related to security ensure to protect the integrity and confidentiality of user data and applications.

The unique security design is built on over one hundred dedicated security mechanisms which create a dense protection shield with redundancy and multiple layers. The security mechanisms provide a comprehensive response to the wide variety of known and expected security attacks. As attacks evolve over time, the distributed approach of the implemented security architecture allows for more proactive and continuous enhancements of the security mechanisms compared to alternative and less versatile approaches. This makes the underlying security architecture of NTAG X DNA a future-proof concept that's built into the product, that effectively counters side channel and fault attacks as well as reverse engineering efforts.

The following sections describe a subset of the security features that are implemented on NTAG X DNA.

### 6.19.2 Reset

The following types of resets and reset sources can be distinguished:

- normal application power-on reset, triggered by the on-chip power-on reset circuit
- internal reset, triggerable by
  - Dedicated software reset
  - On-chip security sensors
  - Electrical operating condition category
  - Internal physical attack category
  - Data integrity protection category

Two different reset severities can be distinguished in the NTAG X DNA hardware. The "normal" chip resets and the "security" resets.

### 6.19.3 Sensor Architecture

The following sensors are implemented on NTAG X DNA:

- Electrical operation condition category
  - Low Frequency Sensor
  - High Frequency Sensor
  - Low Voltage Sensor
  - High Voltage Sensor
- Internal physical attack category
  - Low Temperature Sensor
  - High Temperature Sensor
  - Light Sensors
  - Glitch Sensors
  - Active Shielding
  - ISO/IEC 14443 Frequency Sensor
- Data integrity protection category
  - RAM Integrity Error
  - ROM Integrity Error
  - FLASH Integrity Error
  - internal Bus and Register Integrity Error

### 6.19.4 Scalable Security

NTAG X DNA implements an error counter. The error counter uses a dedicated memory area in the FLASH within a dedicated, protected memory area. The error counter is decremented for security critical errors.

The Scalable Security feature enables additional security countermeasures during operation based on the error counter values to avoid exploitation of repeated attacks. This results in a significant performance degradation in case of repeated security resets, if NTAG X DNA detects that it is under security attacks. From system design perspective this behavior has to be considered to avoid a non functional system due to timeouts by the host in case of activated Scalable Security features. Therefore timeouts should be defined with significant margins in case of additional security countermeasures are activated.

## 7 Command set

### 7.1 Introduction

This section contains the full command set of NTAG X DNA. For each command a figure and a table with the detailed command API is given.

**Note:** For non-standard ISO/IEC 7816-4, i.e. proprietary native commands, the command tables show the native command format, i.e. not repeating the CLA/P1/P2/Lc/Le wrapping for each command, while the figures show the wrapped format as supported by NTAG X DNA. For further explanation, see [Section 6.3.2](#).

**Remark:** In the figures and tables, always CommMode.Plain is presented and the field length is valid for the plain data length. For the CommMode.MAC and CommMode.Full, the cryptogram needs to be calculated according to the secure messaging, see [Section 6.4.6](#), then data field needs to fill with the cryptogram (Plain; CMAC; encrypted data with CMAC). Communication mode and condition are mentioned in the command description.

### 7.2 Supported commands and APDUs

Table 44. APDUs

Command	C-APDU (hex)							R-APDU (hex)		Communication mode
	INS	CLA	INS	P1	P2	Lc	Data	Le	Data	
<a href="#">ActivateConfiguration</a>	90	66	00	00	XX	Data	00	-	9100	CommMode.MAC
<a href="#">AuthenticateEV2First</a> - part 1	90	71	00	00	XX	Data	00	Data	91AF	N/A
<a href="#">AuthenticateEV2First</a> - part 2	90	AF	00	00	20	Data	00	Data	9100	N/A
<a href="#">AuthenticateEV2NonFirst</a> - part 1	90	77	00	00	01	Data	00	Data	91AF	N/A
<a href="#">AuthenticateEV2NonFirst</a> - part 2	90	AF	00	00	20	Data	00	Data	9100	N/A
<a href="#">ChangeFileSettings</a>	90	5F	00	00	XX	Data	00	Data	9100	CommMode.Full
<a href="#">ChangeKey</a>	90	C4	00	00	XX	Data	00	Data	9100	CommMode.Full
<a href="#">CreateCounterFile</a>	90	D0	00	00	8	Data	00	Data	9100	CommMode.MAC
<a href="#">CreateStdDataFile</a>	90	CD	00	00	8	Data	00	Data	9100	CommMode.MAC
<a href="#">CryptoRequest</a>	90	4C	00	00	XX	Data	00	Data	9100	CommMode of <a href="#">Crypto Request</a> as defined by <a href="#">Set Configuration</a> 0x15.
<a href="#">FreeMem</a>	90	6E	00	00	-	-	00	Data	9100	CommMode.MAC
<a href="#">ISOGeneralAuthenticate</a>	00	86	01	00-07	XX	Data	00	Data	9000	N/A
<a href="#">GetCardUID</a>	90	51	00	00	-	-	00	Data	9100	CommMode.MAC
<a href="#">GetConfiguration</a>	90	65	00	00	[1]	[Data]	00	Data	9100	CommMode.Full
<a href="#">GetFileIDs</a>	90	6F	00	00	-	-	00	Data	9100	CommMode.MAC
<a href="#">GetISOFileIDs</a>	90	61	00	00	-	-	00	Data	9100	CommMode.MAC
<a href="#">GetFileSettings</a>	90	F5	00	00	1	Data	00	Data	9100	CommMode.MAC
<a href="#">GetFileCounters</a>	90	F6	00	00	1	Data	00	Data	9100	<a href="#">CommMode.Full</a> for SDMReadCtr retrieval on File Type.StandardData; CommMode of targeted file for FileType.Counter
<a href="#">GetKeySettings</a>	90	45	00	00	[1]	[Data]	00	Data	9100	CommMode.MAC

Table 44. APDUs...continued

Command	C-APDU (hex)							R-APDU (hex)		Communication mode
	INS	CLA	INS	P1	P2	Lc	Data	Le	Data	
<a href="#">GetKeyVersion</a>	90	64	00	00	1	Data	00	Data	9100	CommMode.MAC
<a href="#">GetVersion</a> - part 1	90	60	00	00	[1]	[Data]	00	Data	91AF	CommMode.MAC
<a href="#">GetVersion</a> - part 2	90	AF	00	00	-	-	00	Data	91AF	CommMode.MAC
<a href="#">GetVersion</a> - part 3	90	AF	00	00	-	-	00	Data	9100	CommMode.MAC
<a href="#">IncrementCounterFile</a>	90	F8	00	00	5	Data	00	Data	9100	CommMode of targeted file.
<a href="#">ISOInternalAuthenticate</a>	00	88	00	00..04	14..FF	Data	00	Data	9000	N/A
<a href="#">ManageCARootKey</a>	90	48	00	00	XX	Data	00	Data	9100	CommMode of targeted key, or if targeting not yet existing key, default CommMode of the command as defined by <a href="#">SetConfiguration</a> 0x12.
<a href="#">ManageCertRepo</a>	90	49	00	00	XX	Data	00	Data	9100	CommMode of <a href="#">ManageCertRepo</a> as defined by <a href="#">SetConfiguration</a> 0x13.
<a href="#">ManageGPIO</a>	90	42	00	00	XX	Data	00	Data	9100	CommMode of <a href="#">ManageGPIO</a> as defined by <a href="#">SetConfiguration</a> 0x11.
<a href="#">ManageKeyPair</a>	90	46	00	00	XX	Data	00	Data	9100	CommMode of targeted key, or if targeting not yet existing key, default CommMode of the command as defined by <a href="#">SetConfiguration</a> 0x12.
<a href="#">ProcessSM</a>	90	E5	00	00	XX	Data	00	Data	9100	N/A
<a href="#">ISOReadBinary</a>	00	B0	XX	XX	-	-	00	Data	9000	N/A
<a href="#">ReadCertRepo</a>	90	4A	00	00	2	Data	00	Data	9100	If reading meta-data then CommMode.MAC is applied. Reading a certificate directly from the repository requires access as defined in the Read access condition set during repository creation/ reset.
<a href="#">ReadData</a>	90	AD	00	00	07	Data	00	Data	9100	CommMode of targeted file.
<a href="#">ReadGPIO</a>	90	43	00	00	-	-	00	Data	9100	CommMode of <a href="#">ReadGPIO</a> as defined by <a href="#">SetConfiguration</a> 0x11.
<a href="#">ISOSelectFile</a>	00	A4	04	00	XX	Data	00	Data	9000	N/A
<a href="#">SetConfiguration</a>	90	5C	00	00	XX	Data	00	Data	9100	CommMode.Full
<a href="#">ISOUpdateBinary</a>	00	D6	XX	XX	XX	Data	00	-	9000	N/A
<a href="#">WriteData</a>	90	8D	00	00	XX	Data	00	-	9100	CommMode of targeted file.

7.3 Authentication and Secure Messaging

7.3.1 ISOGeneralAuthenticate

The detailed description of this command can be found in [Section 6.4.2](#).

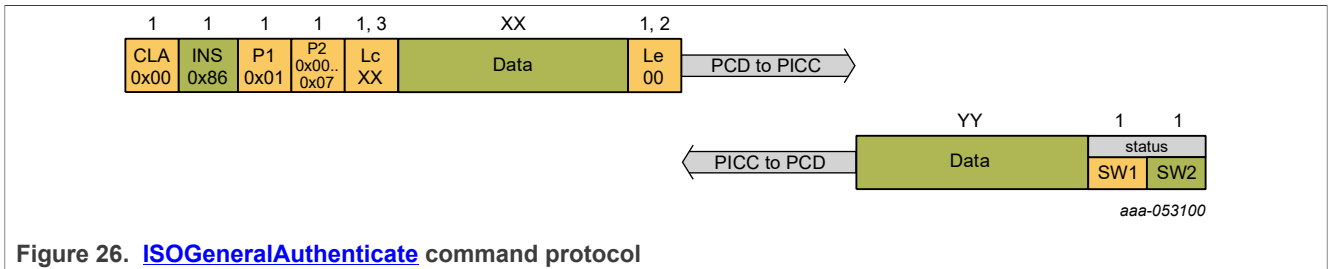

Figure 26. ISOGeneralAuthenticate command protocol

Table 45. Command summary - ISOGeneralAuthenticate

ISOGeneralAuthenticate	
Description:	Asymmetric mutual authentication using SIGMA-I
CommMode:	N/A

Table 46. Command description - ISOGeneralAuthenticate

Name	Length	Value	Description
CLA	1	0x00	
INS	1	0x86	
P1	1	-	Protocol Option
		0x01	SIGMA-I
P2	1	0x00 .. 0x07	Certificate repository Id to use to execute the protocol
Lc	1, 3	0xXX	Length of subsequent data field
Data	XX	-	Message types and payload tags as defined in <a href="#">Table 8</a> and <a href="#">Table 9</a>
Le	1, 2	0x00	Length of expected response

Table 47. Response description - ISOGeneralAuthenticate

Name	Length	Value	Description
Data	YY	-	Message types and payload tags as defined in <a href="#">Table 8</a> and <a href="#">Table 9</a>
SW1SW2	2	0x9000	successful execution
		0XXXXX	Refer to <a href="#">Table 48</a>

Table 48. Error code description - ISOGeneralAuthenticate

SW1 SW2	Value	Description
ISO6E00	0x6E00	Wrong CLA
ISO6A86	0x6A86	Wrong P1 or P2

Table 48. Error code description - **ISOGeneralAuthenticate** ...continued

SW1 SW2	Value	Description
ISO6700	0x6700	Wrong or inconsistent APDU length.
ISO6985	0x6985	Wrapped chained command or multiple pass command ongoing.
ISO6985	0x6985	Not supported at PICC level.
ISO6985	0x6985	Key usage counter enabled and limit reached
ISO6985	0x6985	Protocol option requested is not supported
ISO6988	0x6988	Invalid host ephemeral public key
ISO6988	0x6988	Host message decryption failed
ISO6A82	0x6A82	Certificate level requested is invalid or certificate has already been requested
ISO6A80	0x6A80	Invalid command data format
ISO6300	0x6300	Verification of host signature failed

7.3.2 **ISOInternalAuthenticate**

The detailed description of this command can be found in [Section 6.4.3.3](#).

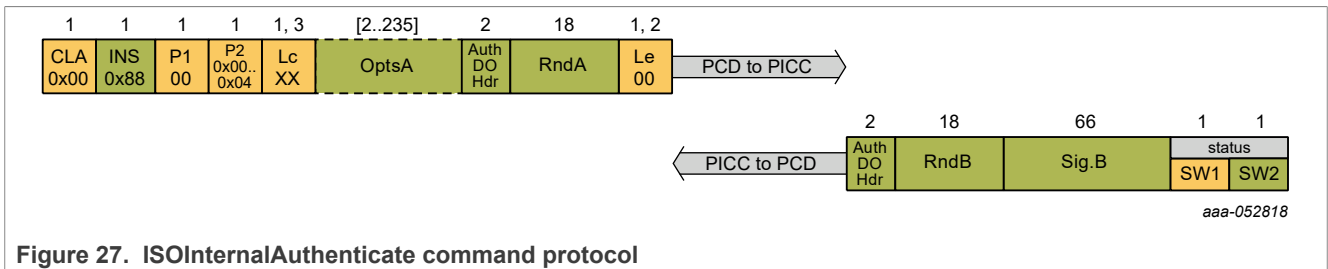

Figure 27. ISOInternalAuthenticate command protocol

Table 49. Command summary - **ISOInternalAuthenticate**

<b>ISOInternalAuthenticate</b>	
Description:	Asymmetric card-unilateral authentication.
CommMode:	N/A

Table 50. Command Description - **ISOInternalAuthenticate**

Name	Length	Value	Description
CLA	1	0x00	
INS	1	0x88	
P1	1	0x00	RFU
P2	1	-	Key addressing
	Bit 7-3	'00000'	Reserved
	Bit 2-0	-	RFU
		0x0..0x4	[if PICC level is not selected] At application level, up to five keys are supported.
	0x1	[if PICC level is selected] Priv.Orig	

Table 50. Command Description - [ISOInternalAuthenticate](#) ...continued

Name	Length	Value	Description
Lc	1,3	0x14..0xFF	Length of subsequent data field
OptsA	[2..235]	-	PCD Option (TLV): RFU
		T: 0x80	Tag
		L: 0x00..0xE9	Length of Value field. Card will accept other lengths and ignore the Value field.
AuthDOHdr	2	-	Authentication Data Objects Header (TL)
		T: 0x7C	Tag
		L: 0x12	Length of subsequent Authentication Data Objects
RndA	18	-	Authentication Data Object: random challenge from PCD (TLV)
		T: 0x81	Tag
		L: 0x10	Length of Value field
		V: RndA	Value: random challenge
Le	1,2	-	Length of expected response
		0x00/0x0000	Any expected length up to resp. 256/65536 bytes.
		0x56..0xFFFF	Max expected length must be at least 86 bytes.

Table 51. Response description - [ISOInternalAuthenticate](#)

Status	Length	Value	Description
AuthDOHdr	2	-	Authentication Data Objects Header (TL)
		T: 0x7C	Tag
		L: 0x54	Length of subsequent Authentication Data Objects
RndB	18	-	Authentication Data Objects: random from PICC (TLV)
		T: 0x7C	Tag
		L: 0x54	Length of subsequent Authentication Data Objects
		V: RndB	Value: random
Sig. B	66	-	Authentication Data Objects: signature from PICC (TLV)
		T: 0x7C	Tag
		L: 0x54	Length of Value field
		V: RndB	Value: $Sig.B = ECDSA_{Sign}(Priv.B; 0xF0F0[ OptsA ] RndB RndA)$
SW1    SW2	2	0x9000 0XXXXX	Correct execution Refer to <a href="#">Table 52</a>

Table 52. Error code description - [ISOInternalAuthenticate](#)

SW1 SW2	Value	Description
Resp.ISO6700	0x6700	Wrong or inconsistent APDU length.
Resp.ISO6984	0x6984	ECC-based Card-Unilateral Authentication disabled via the key policy of the targeted key.

Table 52. Error code description - [ISOInternalAuthenticate](#) ...continued

SW1 SW2	Value	Description
Resp.ISO6985	0x6985	Originality Check with key 0x1 at PICC level disabled due to enhanced privacy configuration.
Resp.ISO6985	0x6985	Current state different from VCState.NotAuthenticated
Resp.ISO6985	0x6985	ECC-based Card-Unilateral Authentication disabled over I2C interface. ECC-based Card-Unilateral Authentication disabled over NFC interface.
Resp.ISO6985	0x6985	KeyUsageCtrLimit enabled for targeted key has been reached.
Resp.ISO6987	0x6987	Expected DO missing.
Resp.ISO6987	0x6987	Unexpected DO recieved.
Resp.ISO6A86	0x6A86	Wrong parameter P1: different from 0x00.
Resp.ISO6A86	0x6A86	Wrong parameter P2: RFU bits set.
Resp.ISO6A88	0x6A88	Wrong parameter P2: Key targeted by PrivKeyNo does not exist.
Resp.ISO6C00	0x6C00	Wrong Le: expected length insufficient for response data.

7.3.3 [AuthenticateEV2First](#)

The detailed description of this command can be found in [Section 6.4.4.1](#).

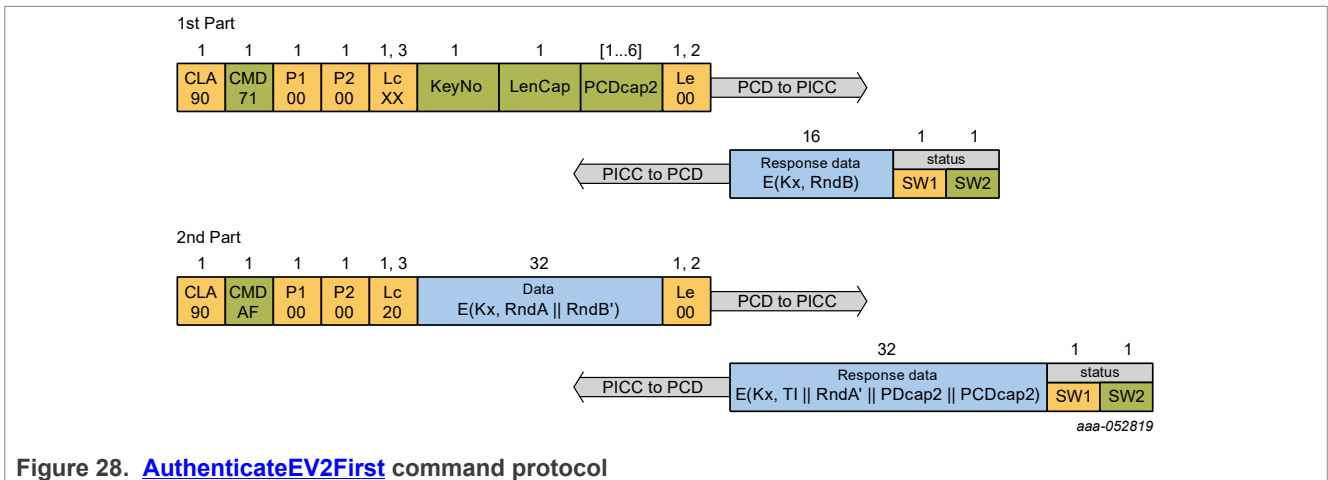

Figure 28. [AuthenticateEV2First](#) command protocol

Table 53. Command summary - [AuthenticateEV2First](#)

<a href="#">AuthenticateEV2First</a>	
Description:	Symmetric mutual authentication. This authentication is intended to be the first in a transaction.
CommMode:	N/A

Table 54. Command description - [AuthenticateEV2First](#) - Part1

Name	Length	Value	Description
<b>Command Header Parameters</b>			
CMD	1	0x71	Command code.
KeyNo	1		Targeted authentication key
	Bit 7-6	00b	RFU
	Bit 5-0	0x0 to 0x4	Key number
LenCap	1	0x00 to 0x06	Length of the PCD Capabilities. [This value should be set to 0x00].
PCDcap2.1	[1]	-	Capability vector of the PCD.
	Bit 7-2	Full range	RFU, can hold any value
	Bit 1	0b	EV2 secure messaging
	Bit 0	Full range	RFU, can hold any value
PCDcap2.2-6	[1..5]	Full range	Capability vector of the PCD. All other bytes but PCDcap2.1 are optional, RFU and can hold any value. [If LenCap set to 0x00, no PCDcap2 present]
<b>Command Data Parameters</b>			
-	-	-	No data parameters

Table 55. Response description - [AuthenticateEV2First](#) - Part1

Name	Length	Value	Description
E(Kx, RndB)	16	Full range	Encrypted PICC challenge The following data, encrypted with the key Kx referenced by KeyNo: - RndB: 16 byte random from PICC
SW1SW2	2	0x91AF 0x91XX	successful execution Refer to <a href="#">Table 55</a>

Table 56. Error code description - [AuthenticateEV2First](#) - Part1

Status	Value	Description
COMMAND_ABORTED	0xCA	Chained command or multiple pass command ongoing.
LENGTH_ERROR	0x7E	Command size not allowed.
PARAMETER_ERROR	0x9E	Parameter value not allowed.
NO_SUCH_KEY	0x40	Targeted key does not exist
PERMISSION_DENIED	0x9D	Targeted key not available for authentication.
		AES-based Symmetric Authentication disabled over I2C interface. AES-based Symmetric Authentication disabled over NFC interface.
		AuthCtrLimit enabled for AES-based authentication has been reached.

Table 57. Command description - [AuthenticateEV2First](#) - Part2

Name	Length	Value	Description
CMD	1	0xAF	Additional frame
E(Kx, RndA    RndB')	32	Full range	Encrypted PCD challenge and response The following data, encrypted with the key Kx referenced by KeyNo: - RndA: 16 byte random from PCD. - RndB': 16 byte RndB rotated left by 1 byte

Table 58. Response description - [AuthenticateEV2First](#) - Part2

Name	Length	Value	Description
E(Kx, TI    RndA'    PDcap2    PCDcap2)	32	Full range	Encrypted PICC response The following data encrypted with the key referenced by KeyNo: - TI: 4 byte Transaction Identifier - RndA': 16 byte RndA rotated left by 1 byte. - PDcap2: 6 byte PD capabilities - PCDcap2: 6 byte PCD capabilities
SW1SW2	2	0x9100 0x91XX	successful execution Refer to <a href="#">Table 59</a>

Table 59. Error code description - [AuthenticateEV2First](#) - Part2

Status	Value	Description
COMMAND_ABORTED	0xCA	AWDT1 already expired
LENGTH_ERROR	0x7E	Command size not allowed.
AUTHENTICATION_ERROR	0xAE	Wrong RndB'

7.3.4 **AuthenticateEV2NonFirst**

The detailed description of this command can be found in [Section 6.4.4.2](#).

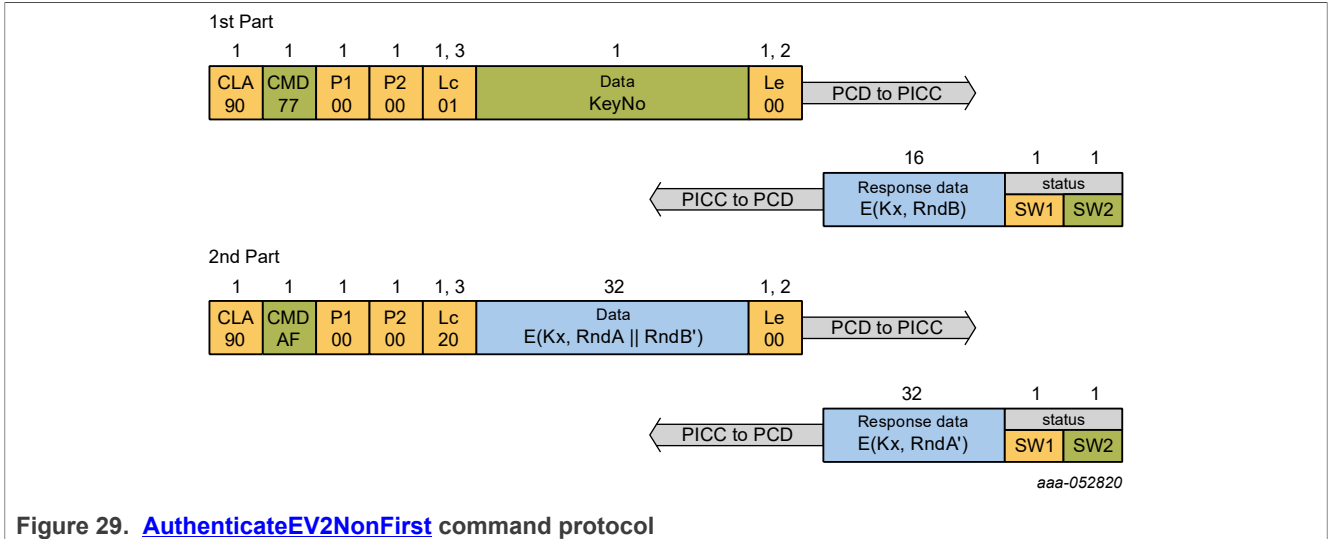

Figure 29. **AuthenticateEV2NonFirst** command protocol

Table 60. Command summary - **AuthenticateEV2NonFirst**

<b>AuthenticateEV2NonFirst</b>	
Description:	Symmetric mutual authentication. This authentication is intended for any subsequent authentication after <a href="#">AuthenticateEV2First</a> in a transaction.
CommMode:	N/A

Table 61. Command description - **AuthenticateEV2NonFirst** - Part1

Name	Length	Value	Description
<b>Command Header Parameters</b>			
CMD	1	0x77	Command code.
KeyNo	1		Targeted authentication key
	Bit 7-6	0	RFU
	Bit 5-0	0x0 to 0x04	Key number
<b>Command Data Parameters</b>			
-	-	-	No data parameters

Table 62. Response description - **AuthenticateEV2NonFirst** - Part1

Name	Length	Value	Description
E(Kx, RndB)	16	Full range	Encrypted PICC challenge The following data, encrypted with the key Kx referenced by KeyNo: - RndB (16 byte): Random number from the PICC.
SW1SW2	2	0x91AF 0x91XX	successful execution Refer to <a href="#">Table 63</a>

Table 63. Error code description - [AuthenticateEV2NonFirst](#) - Part1

Status	Value	Description
COMMAND_ABORTED	0xCA	Chained command or multiple pass command ongoing.
LENGTH_ERROR	0x7E	Command size not allowed.
PARAMETER_ERROR	0x9E	Parameter value not allowed.
NO_SUCH_KEY	0x40	Targeted key does not exist
PERMISSION_DENIED	0x9D	Not in VCState.AuthenticatedAES.
		Targeted key not available for authentication.
		AES-based Symmetric Authentication disabled over I2C interface. AES-based Symmetric Authentication disabled over NFC interface.

Table 64. Command description - [AuthenticateEV2NonFirst](#) - Part2

Name	Length	Value	Description
CMD	1	0xAF	Additional frame
E(Kx, RndA    RndB')	32	Full range	Encrypted PCD challenge and response The following data, encrypted with the key Kx referenced by KeyNo: - RndA: 16 byte random from PCD. - RndB': 16 byte RndB rotated left over 1 byte.

Table 65. Response description - [AuthenticateEV2NonFirst](#) - Part2

Name	Length	Value	Description
E(Kx, RndA')	16	Full range	Encrypted PICC challenge and response The following data, encrypted with the key Kx referenced by KeyNo: - RndA: 16 byte random from PCD. - RndB': 16 byte RndB rotated left over 1 byte.
SW1SW2	2	0x9100 0x91XX	successful execution Refer to <a href="#">Table 66</a>

Table 66. Error code description - [AuthenticateEV2NonFirst](#) - Part2

Status	Value	Description
COMMAND_ABORTED	0xCA	AWDT1 already expired
LENGTH_ERROR	0x7E	Command size not allowed.
AUTHENTICATION_ERROR	0xAE	Wrong RndB'

7.3.5 **ProcessSM**

The detailed description of this command can be found in subsection [Section 6.4.7.1](#). Instantiations are listed in the subsequent settings. Note that as the regular secure messaging does not apply for these commands, the color coding of the different fields does not apply to distinguish CmdHeader and CmdData parameters.

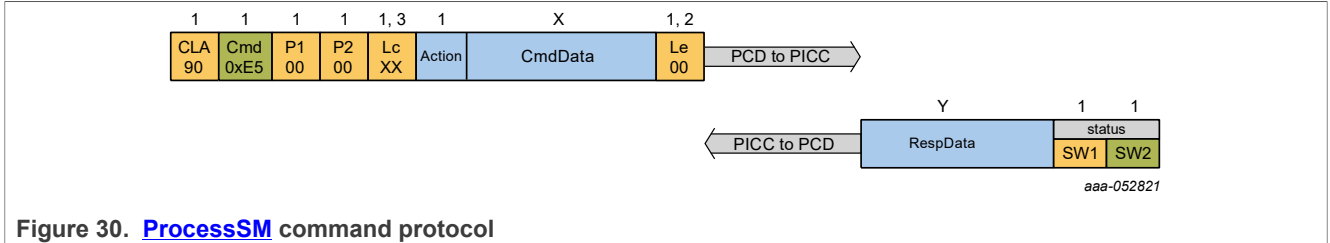

Figure 30. **ProcessSM** command protocol

Table 67. Command summary - **ProcessSM**

<b>ProcessSM</b>	
Description:	Processes controller secure messaging. This is the generic API definition, including common error codes. Specific operations are further defined by dedicated subcommands.
CommMode:	N/A

Table 68. Command Description - **ProcessSM**

Name	Length	Value	Description
<b>Command Header Parameters</b>			
CMD	1	0xE5	Command code.
<b>Command Data Parameters</b>			
Action	1	Full range	Targeted action
CmdData	X	-	Action specific command data

Table 69. Response Description - **ProcessSM**

Status	Length	Value	Description
RespData	Y	-	Action specific response data
SW1SW2	2	0x9000 0XXXXX	successful execution Refer to <a href="#">Table 70</a>

Table 70. Error code description - **ProcessSM**

Status	Value	Description
COMMAND_ABORTED	0xCA	Chained command or multiple pass command ongoing.
LENGTH_ERROR	0x7E	Command size not allowed.
PARAMETER_ERROR	0x9E	Parameter value not allowed.
PARAMETER_ERROR	0x9E	Invalid action.
PERMISSION_DENIED	0x9D	<a href="#">ProcessSM</a> disabled for the targeted interface.
PERMISSION_DENIED	0x9D	Not supported at PICC level.

Table 70. Error code description - **ProcessSM** ...continued

Status	Value	Description
PERMISSION_DENIED	0x9D	Not supported in VCState.NotAuthenticated
PERMISSION_DENIED	0x9D	Not supported in VCState.AuthenticatedAES

7.3.6 **ProcessSM\_Apply**

This is an instantiation of **ProcessSM**. The detailed description of this command can be found in [Section 6.4.7.2](#).

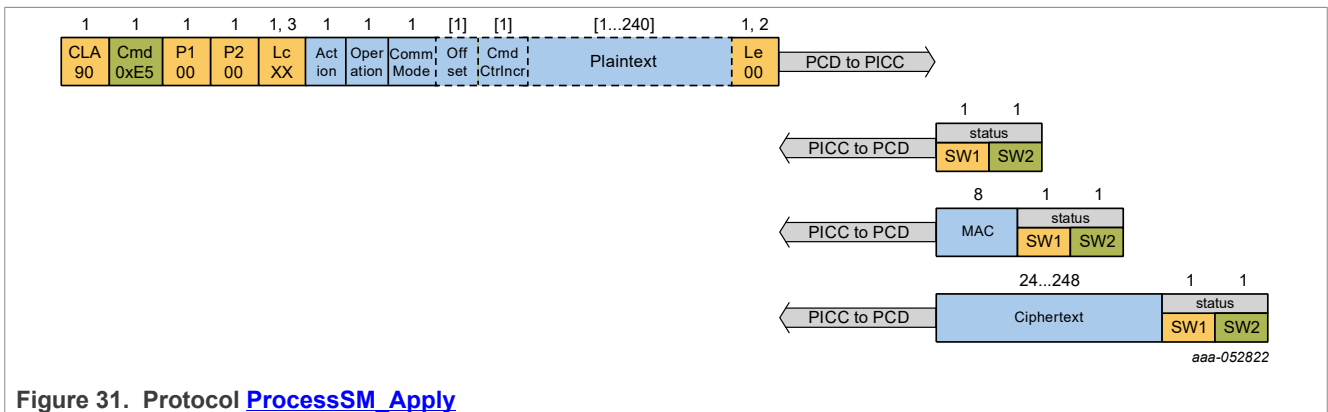

Figure 31. Protocol **ProcessSM\_Apply**

Table 71. Command summary - **ProcessSM\_Apply**

<b>ProcessSM_Apply</b>	
Description:	Applies secure messaging for the given command.
CommMode:	N/A

Table 72. Command Description - **ProcessSM\_Apply**

Name	Length	Value	Description
<b>Command Header Parameters</b>			
CMD	1	0xE5	Command code.
<b>Command Data Parameters</b>			
Action	1	-	Targeted action
		0x01	Apply secure messaging.
Operation	1	-	Targeted action
		0x04	One-shot operation
CommMode	1	-	ProtectionMode
	Bit 7-6	'00'	RFU
	Bit 5-4	-	Communication mode
		'x0'	<a href="#">CommMode.Plain</a>
		'01'	<a href="#">CommMode.MAC</a>
		'11'	<a href="#">CommMode.Full</a>
	Bit 3-0	'0000'	RFU

Table 72. Command Description - [ProcessSM\\_Apply](#)...continued

Name	Length	Value	Description
Offset	[1]	-	[Optional,present if <a href="#">CommMode.Full</a> ]
		0x01..0xEF	Index of the first byte of CmdData in Data field.
CmdCtrIncr	[1]	-	[Optional,present if <a href="#">CommMode.Plain</a> ]
		0x01..0xFF	Command counter increment value
Plaintext	[1..240]	-	[Optional,present if not <a href="#">CommMode.Plain</a> ]
		Full range	Plain data to protect

Table 73. Response Description - [ProcessSM\\_Apply](#)

Status	Length	Value	Description
-	0	-	[if <a href="#">CommMode.Plain</a> ] No response data
MAC	8	Full range	[if <a href="#">CommMode.MAC</a> ] MAC
Ciphertext	24..248	Full range	[if <a href="#">CommMode.Full</a> ] Encrypted data and MAC
SW1SW2	2	0x9000 0XXXXX	successful execution Refer to <a href="#">Table 74</a>

Table 74. Error code description - [ProcessSM\\_Apply](#)

Status	Value	Description
LENGTH_ERROR	0x7E	If <a href="#">CommMode.MAC</a> , Data length bigger than 240 is not supported.
LENGTH_ERROR	0x7E	If <a href="#">CommMode.Full</a> , Data length bigger than 239 is not supported.
INTEGRITY_ERROR	0x1E	If <a href="#">CommMode.Plain</a> , <a href="#">CmdCtr</a> reaches 0xFFFF or overflows.
INTEGRITY_ERROR	0x1E	If <a href="#">CommMode.MAC</a> or <a href="#">CommMode.Full</a> , <a href="#">CmdCtr</a> reached 0xFFFF already.

7.3.7 [ProcessSM\\_Remove](#)

This is an instantiation of [ProcessSM](#). The detailed description of this command can be found in [Section 6.4.7.3](#).

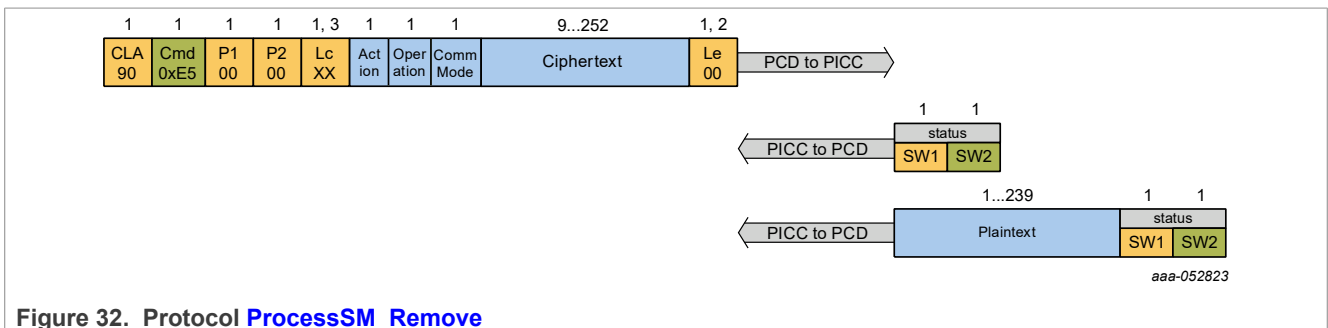

Figure 32. Protocol [ProcessSM\\_Remove](#)

Table 75. Command summary - [ProcessSM\\_Remove](#)

<a href="#">ProcessSM_Remove</a>	
Description:	Applies secure messaging for the given command.
CommMode:	N/A

Table 76. Command Description - [ProcessSM\\_Remove](#)

Name	Length	Value	Description
<b>Command Header Parameters</b>			
CMD	1	0xE5	Command code.
<b>Command Data Parameters</b>			
Action	1	-	Targeted action
		0x02	Remove secure messaging
Operation	1	-	Targeted action
		0x04	One-shot operation
CommMode	1	-	ProtectionMode
	Bit 7-6	'00'	RFU
	Bit 5-4	-	Communication mode
		'x0'	RFU
		'01'	<a href="#">CommMode.MAC</a>
		'11'	<a href="#">CommMode.Full</a>
	Bit 3-0	'0000'	RFU
Ciphertext	9..252	-	Response data
		Full range	[if <a href="#">CommMode.MAC</a> ] RC[   RespData]    MAC
		Full range	[if <a href="#">CommMode.Full</a> ] RC[   encrypted RespData]    MAC
		'01'	<a href="#">CommMode.MAC</a>
		'11'	<a href="#">CommMode.Full</a>

Table 77. Response Description - [ProcessSM\\_Remove](#)

Status	Length	Value	Description
-	0	-	[if <a href="#">CommMode.MAC</a> ] No response data
Plaintext	1..239	Full range	[if <a href="#">CommMode.Full</a> ] Encrypted data and MAC
SW1SW2	2	0x9000 0xFFFF	successful execution Refer to <a href="#">Table 78</a>

Table 78. Error code description - [ProcessSM\\_Remove](#)

Status	Value	Description
LENGTH_ERROR	0x7E	If <a href="#">CommMode.MAC</a> , Data length bigger than 252 is not supported.
LENGTH_ERROR	0x7E	If <a href="#">CommMode.Full</a> , Data length bigger than 249 is not supported.
INTEGRITY_ERROR	0x1E	Padding error in cryptogram or invalid secure messaging MAC

7.4 Memory and Configuration Management

7.4.1 FreeMem

The detailed description of this command can found in [Section 6.6.3.4.1](#).

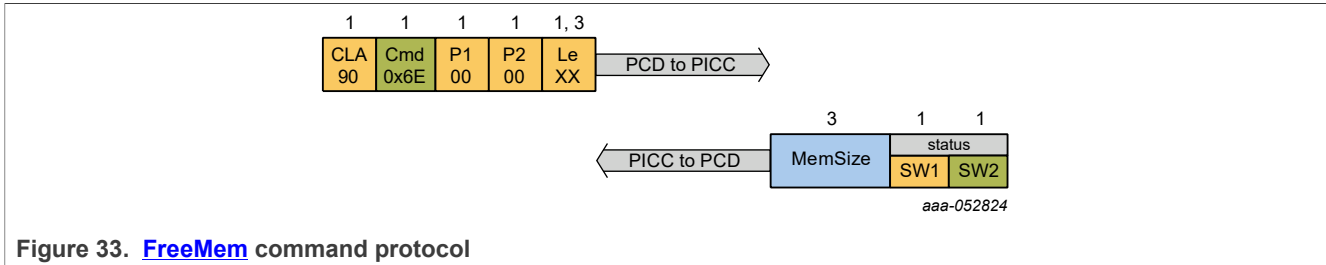

Figure 33. FreeMem command protocol

Table 79. Command summary - FreeMem

FreeMem	
Description:	Returns the free memory available on the card.
CommMode:	<a href="#">CommMode.MAC</a>

Table 80. Command description - FreeMem

Name	Length	Value	Description
<b>Command Header Parameters:</b>			
Cmd	1	0x6E	Command code.
<b>Command Data Parameters:</b>			
-	-	-	No data parameters:

Table 81. Response description - FreeMem - OPERATION\_OK

Name	Length	Value	Description
MemSize	3	-	Size of the free memory
SW1SW2	2	0x9100 0x91XX	successful execution Refer to <a href="#">Table 82</a>

Table 82. Error code description - FreeMem

Status	Value	Description
COMMAND_ABORTED	0xCA	Chained command or multiple pass command ongoing.
INTEGRITY_ERROR	0x1E	Invalid secure messaging MAC.
LENGTH_ERROR	0x7E	Command size not allowed.
MEMORY_ERROR	0xEE	Failure when reading or writing to non-volatile memory.

7.4.2 SetConfiguration

The detailed description of this command can found in [Section 6.6.3.2](#).

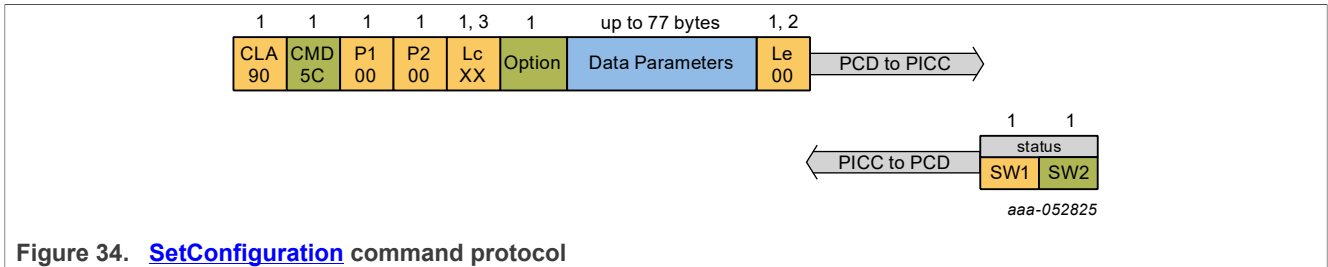

Figure 34. SetConfiguration command protocol

Table 83. Command Description - SetConfiguration

SetConfiguration	
Description:	Configures several aspects of the application.
CommMode:	<a href="#">CommMode.Full</a>

Table 84. Command description - SetConfiguration

Name	Length	Value	Description
<b>Command Header Parameters</b>			
Cmd	1	0x5C	Command code.
Option	1	-	Configuration Option. It defines the length and content of the Data parameter. The Option byte is transmitted in plain text, whereas the Data is always transmitted in <a href="#">CommMode.Full</a> .
		0x00	PICC configuration.
		0x02	ATS Update
		0x03	SAK Update
		0x04	Secure Messaging Configuration.
		0x05	Capability data.
		0x0C	ATQA update
		0x0D	Silent Mode configuration
		0x0E	Enhanced Privacy configuration
		0x0F	NFC Management
		0x10	I2C Management
		0x11	GPIO Management
		0x12	ECC Key Management
		0x13	Certificate Management
		0x14	Watchdog Timer Management
		0x15	CryptoAPI Management
		0x16	Authentication Counter and Limit Configuration
		0x17	HALT and Wake-up Configuration
0xFE	Deferred Configurations		

Table 84. Command description - [SetConfiguration](#) ...continued

Name	Length	Value	Description
		0xFF	Lock Configurations
		Other values	RFU
Command Data Parameters			
Data	Up to 77 bytes	-	Data content depends on option values.
		Full range	Data content depends on option value as defined in <a href="#">set ConfigOptionsList Table</a> .

Table 85. Response description - [SetConfiguration](#)

Name	Length	Value	Description
SW1SW2	2	0x9100 0x91XX	successful execution Refer to <a href="#">Table 86</a>

Table 86. Error code description - [SetConfiguration](#)

Status	Value	Description
COMMAND_ABORTED	0xCA	Chained command or multiple pass command ongoing.
INTEGRITY_ERROR	0x1E	Invalid cryptogram (padding or CRC). Invalid secure messaging MAC.
LENGTH_ERROR	0x7E	Command size not allowed. Option 0x00: Data length is not 1 Option 0x02: Data length is not in the range [1..20] Option 0x03: Data length is not 2 Option 0x04: Data length is not 2 Option 0x05: Data length is not 10 Option 0x0C: Data length is not 2 Option 0x0D: Data length is not 1 or 3 Option 0x0E: Data length is not 2 Option 0x0F: Data length is not 3 Option 0x10: Data length is not 4 Option 0x11: Data length is not 28 Option 0x12: Data length is not 2 Option 0x13: Data length is not 4 Option 0x14: Data length is not 3 Option 0x15: Data length is not between 3 and 71 Option 0x16: Data length is not 6 Option 0x17: Data length is not 4 Option 0xFE: Unaccepted Data length Option 0xFF: Data length is not 3
PARAMETER_ERROR	0x9E	Parameter value not allowed. Option 0x00: Data bit 7-2 or bit 0 not set to 0b. Option 0x02: TL inconsistent with length of received ATS string. Option 0x02: Data bit 7-2 or bit 0 not set to 0b. Option 0x0D: given REQS equals given WUPS. Option 0x0F: unsupported protocol set.

Table 86. Error code description - [SetConfiguration](#)...continued

Status	Value	Description
		Option 0x10: unsupported protocol set. Option 0x11: unsupported GPIO1Mode, GPIO2Mode, GPIO1Notif, GPIO2 Notif set. Option 0x13: unsupported cache size set. Option 0x13: unsupported feature selected. Option 0x14: unsupported timer value. Option 0x16: unsupported AuthCtrOption. Option 0x17: unsupported configuration. Option 0xFE: unsupported Option or Method values. Unsupported option (i.e. Reserved).
PERMISSION_DENIED	0x9D	Option not supported / allowed at PICC level Option not supported by product configuration
FILE_NOT_FOUND	0xF0	Option 0x16: invalid AuthCtrFileID: file does not exist.
AUTHENTICATION_ERROR	0xAE	No active authentication with <a href="#">AppMasterKey</a> .
CERT_ERROR	0xAE	Active ECC-based authentication not granting <a href="#">AppMasterKey</a> access rights.

7.4.3 [GetConfiguration](#)

The detailed description of this command can be found in [Section 6.6.3.3](#).

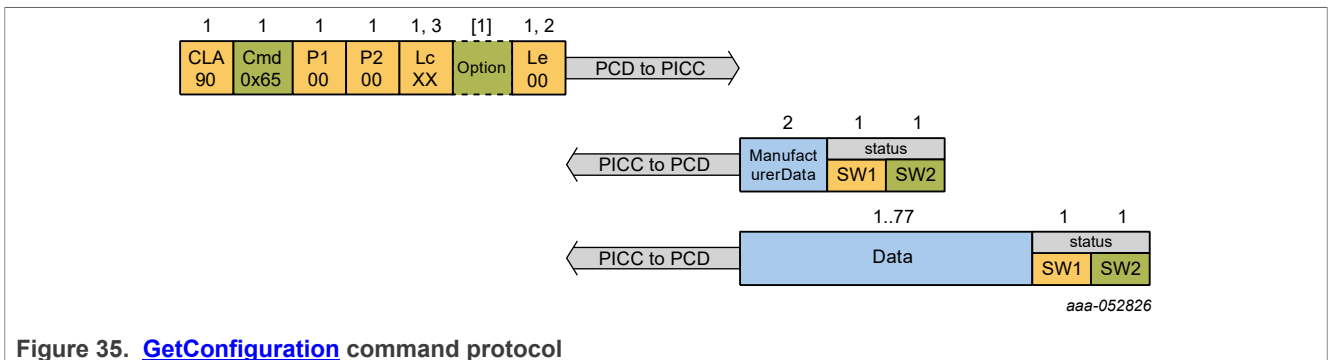

Table 87. Command summary - [GetConfiguration](#)

<a href="#">GetConfiguration</a>	
Description:	Retrieves configuration aspects of the card or the application.
CommMode:	<a href="#">CommMode.Full</a>

Table 88. Command Description - [GetConfiguration](#)

Name	Length	Value	Description
<b>Command Header Parameters</b>			
CMD	1	0x65	Command code.
Option	[1]	-	Configuration Option. If absent, manufacturer configuration data is returned.
		Limited range	For supported options, see <a href="#">SetConfiguration</a> .

Table 89. Response description - [GetConfiguration](#)

Status	Length	Value	Description
ManufacturerData	2	-	[if no Option provided]
Data	1..77	-	[if Option provided] Data content and length depends on option value as defined in <a href="#">Table 24</a> .
SW1SW2	2	0x9100 0x91XX	successful execution Refer to <a href="#">Table 90</a>

Table 90. Error code description - [GetConfiguration](#)

Status	Value	Description
COMMAND_ABORTED	0xCA	Chained command or multiple pass command ongoing.
INTEGRITY_ERROR	0x1E	Invalid secure messaging MAC.
LENGTH_ERROR	0x7E	Command size not allowed.
PARAMETER_ERROR	0x9E	Unsupported Option.
PERMISSION_DENIED	0x9D	Option not supported at PICC level.
PERMISSION_DENIED	0x9D	Option disabled by product configuration, see <a href="#">SetConfiguration</a> .
AUTHENTICATION_ERROR	0xAE	No active authentication with required key for the issued Option, see <a href="#">SetConfiguration</a> .
AUTHENTICATION_ERROR	0xAE	No active authentication with <a href="#">AppMasterKey</a> if issued without Option.
CERT_ERROR	0xCE	Active ECC-based authentication not granting access rights for the issued Option, see <a href="#">SetConfiguration</a> .
CERT_ERROR	0xCE	Active ECC-based authentication not granting <a href="#">AppMasterKey</a> access rights if issued without Option.

7.4.4 [ActivateConfiguration](#)

The detailed description of this command can be found in [Section 7.4.4](#).

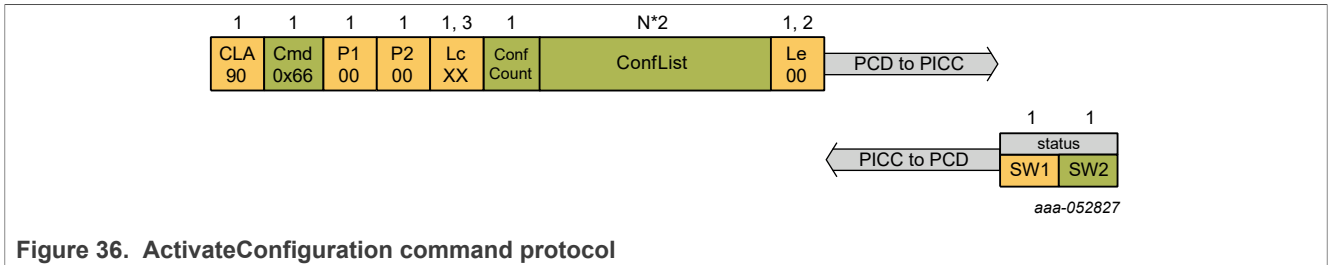

Figure 36. ActivateConfiguration command protocol

Table 91. Command summary - [ActivateConfiguration](#)

<a href="#">ActivateConfiguration</a>	
Description:	Activates a deferred configuration.
CommMode:	<a href="#">CommMode.MAC</a>

Table 92. Command Description - [ActivateConfiguration](#)

Name	Length	Value	Description
<b>Command Header Parameters</b>			
CMD	1	0x66	Command code.
ConfCount	1	0x01 .. 0x04	Number of configurations to be activated (N).
ConfList	N*2	-	List of configurations to be activated (with size N*2). List must hold one or more of following values.
		0x5C 0x00	activate <a href="#">SetConfiguration</a> 0x01 (RandomID)
		0x5C 0x0D	activate <a href="#">SetConfiguration</a> 0x0D (Silent Mode)
		0x5C 0x11	activate <a href="#">SetConfiguration</a> 0x11 (TagTamper boot measurements)
		0x5F 0x01	activate <a href="#">ChangeFileSettings</a> SDM encryptions
<b>Command Data Parameters</b>			
-	-	-	No data parameters

Table 93. Response description - [ActivateConfiguration](#)

Status	Length	Value	Description
ManufacturerData	2	-	[if no Option provided]
Data	1..77	-	[if Option provided] Data content and length depends on option value as defined in <a href="#">Table 24</a> .
SW1SW2	2	0x9100 0x91XX	successful execution Refer to <a href="#">Table 93</a>

Table 94. Error code description - ActivateConfiguration

Status	Value	Description
OPERATION_OK	0x00	
COMMAND_ABORTED	0xCA	Chained command or multiple pass command ongoing.
INTEGRITY_ERROR	0x1E	Invalid secure messaging MAC.
LENGTH_ERROR	0x7E	Command size not allowed.
PARAMETER_ERROR	0x9E	Parameter value not allowed.
PERMISSION_DENIED	0x9D	Parameter value not configured for ActivateConfiguration or already activated.

7.4.5 GetVersion

The detailed description of this command can be found in [Section 6.6.2.1](#).

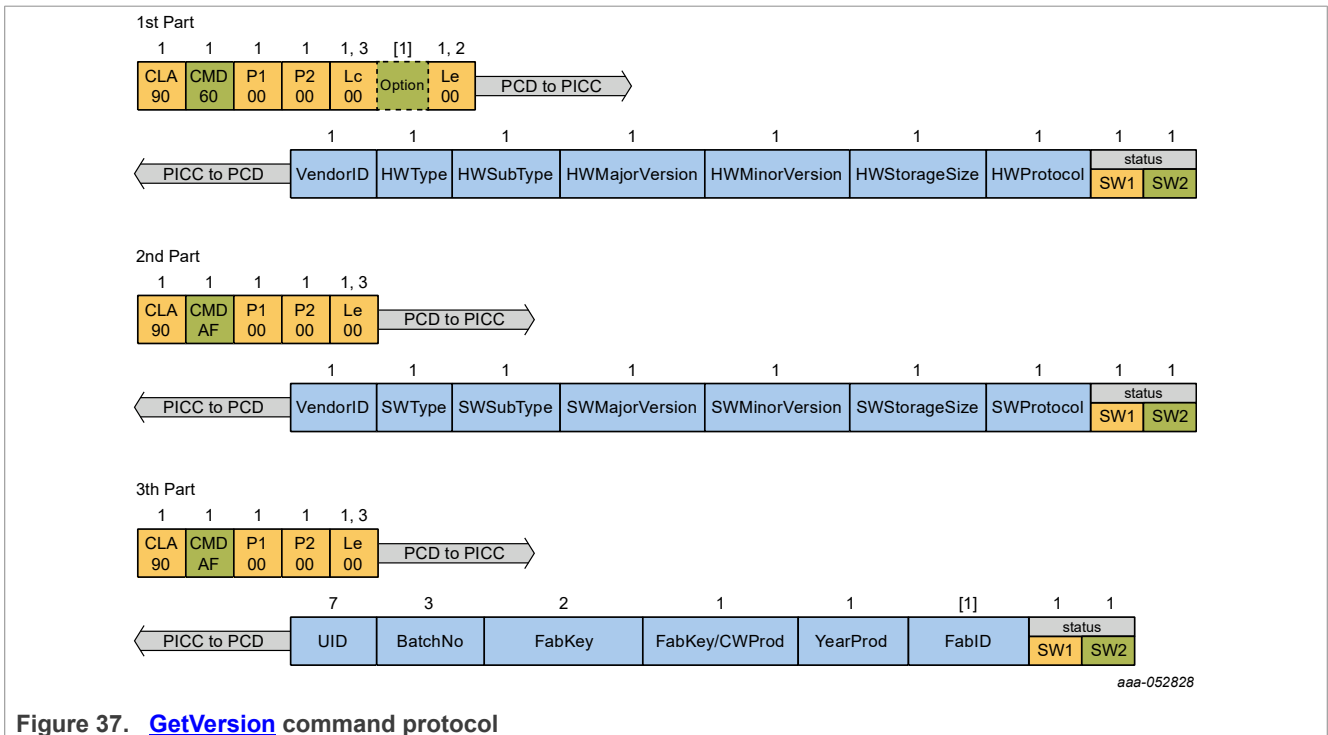

Table 95. Command summary - [GetVersion](#)

<a href="#">GetVersion</a>	
Description:	Returns manufacturing related data.
CommMode:	<a href="#">CommMode.MAC</a>

Part 1

Table 96. Command parameters description - [GetVersion](#) - Part1

Name	Length	Value	Description
<b>Command Header Parameters</b>			
Cmd	1	0x60	Command code.

Table 96. Command parameters description - [GetVersion](#) - Part1 ...continued

Name	Length	Value	Description
Option	[1]	-	[Optional] Option byte
		0x01	Return Fab Identifier
<b>Command Data Parameters</b>			
-	-	-	No data parameters

Table 97. Response description - [GetVersion](#) - Part1

Name	Length	Value	Description
VendorID	1	0x04	Vendor ID
HWType	1	0x04	HW type for NTAG
HWSubType	1	-	HW subtype
		0x41	17 pF, Tag Tamper
		0x43	50 pF, Tag Tamper
HWMajorVersion	1	0xA0	HW major version number
HWMinorVersion	1	0x00	HW minor version number
HWStorageSize	1	-	HW storage size
		0x1A	8 KB
		0x1C	16 KB
		other values	RFU
HWProtocol	1	-	HW communication protocol type
		0x15	ISO/IEC 14443-4 support with Silent Mode support
		0x20	I <sup>2</sup> C
		0x35	I <sup>2</sup> C and ISO/IEC 14443-4 support with Silent Mode support
SW1SW2	2	0x91AF	successful execution
		0x91XX	Refer to <a href="#">Table 102</a>

## Part 2

Table 98. Command parameters description - [GetVersion](#) - Part2

Name	Length	Value	Description
CMD	1	0xAF	Additional frame request.
Data	0	-	No data parameters:

Table 99. Response description - [GetVersion](#) - Part2

Name	Length	Value	Description
VendorID	1	0x04	Vendor ID
SWType	1	0x04	SW type for NTAG
SWSubType	1	0x01	SW subtype

Table 99. Response description - [GetVersion](#) - Part2 ...continued

Name	Length	Value	Description
SWMajorVersion	1	0x00	SW major version number
SWMinorVersion	1	0x01	SW minor version number
SWStorageSize	1	-	SW storage size
		0x1A	8 KB
		0x1C	16 KB
		other values	RFU
SWProtocol	1	-	SW communication protocol type
		0x15	ISO/IEC 14443-4 support with Silent Mode support
		0x20	I <sup>2</sup> C
		0x35	I <sup>2</sup> C and ISO/IEC 14443-4 support with Silent Mode support
SW1SW2	2	0x91AF	successful execution
		0x91XX	Refer to <a href="#">Table 102</a>

### Part 3

Table 100. Command parameters description - [GetVersion](#) - Part3

Name	Length	Value	Description
CMD	1	0xAF	Additional frame request.
Data	0	-	No data parameters:

Table 101. Response description - [GetVersion](#) - Part3

Name	Length	Value	Description
UID	7	-	UID
		All zero	if configured for RandomID
		Full range	UID if not configured for RandomID
BatchNo	3	-	Production batch number
		All zero	if manufacturer data masking is enabled
FabKeyID	2	-	
		Limited range	AlphaNumeric ASCII encoding
		All zero	if manufacturer data masking is enabled
CWProd	1	-	Calendar week of production
		0x01..0x52	BCD coding
		All zero	if manufacturer data masking is enabled
YearProd	1	-	Year of production
		Full range	if manufacturer data masking is disabled
		All zero	if manufacturer data masking is enabled

Table 101. Response description - [GetVersion](#) - Part3 ...continued

Name	Length	Value	Description
FabID	[1]	-	[Optional, present if Option = 0x01] Fab Identifier
		Full range	FabID mapping
		All zero	if manufacturer data masking is enabled
SW1SW2	2	0x9100 0x91XX	Successful execution Refer to <a href="#">Table 102</a>

Table 102. Error code description - [GetVersion](#)

Status	Value	Description
COMMAND_ABORTED	0xCA	Chained command or multiple pass command ongoing.
INTEGRITY_ERROR	0x1E	Invalid secure messaging MAC (only).
LENGTH_ERROR	0x7E	Command size not allowed.
PARAMETER_ERROR	0x9E	Parameter value not allowed.

7.4.6 [GetCardUID](#)

The detailed description of this command can be found in [Section 6.6.1.2](#).

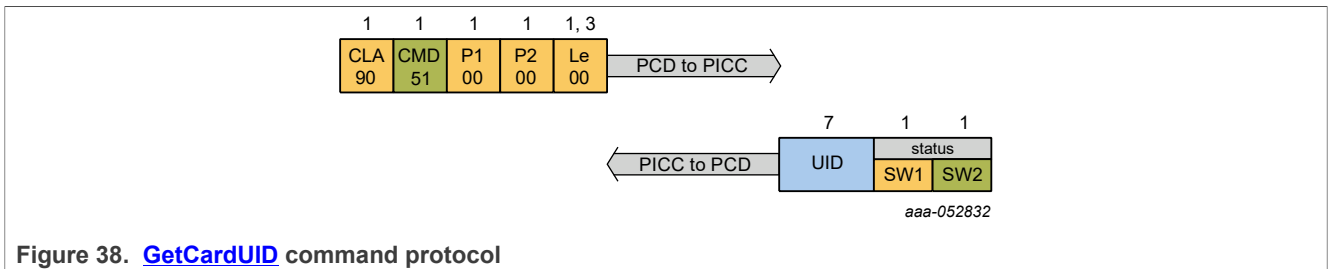

Figure 38. [GetCardUID](#) command protocol

Table 103. Command summary - [GetCardUID](#)

<a href="#">GetCardUID</a>	
Description:	Returns manufacturing related data.
CommMode:	<a href="#">CommMode.MAC</a>

Table 104. Command parameters description - [GetCardUID](#)

Name	Length	Value	Description
<b>Command Header Parameters</b>			
Cmd	1	0x51	Command code.
<b>Command Data Parameters</b>			
-	-	-	No data parameters

Table 105. Response description - [GetCardUID](#)

Name	Length	Value	Description
UID	7	Full range	UID of the NTAG X DNA

Table 105. Response description - [GetCardUID](#) ...continued

Name	Length	Value	Description
SW1SW2	2	0x9100 0x91XX	successful execution Refer to <a href="#">Table 106</a>

Table 106. Error code description - [GetCardUID](#)

Status	Value	Description
COMMAND_ABORTED	0xCA	Chained command or multiple pass command ongoing.
INTEGRITY_ERROR	0x1E	Invalid secure messaging MAC (only).
LENGTH_ERROR	0x7E	Command size not allowed.
PERMISSION_DENIED	0x9D	Not supported at PICC level.
AUTHENTICATION_ERROR	0xAE	No active authentication
AUTHENTICATION_ERROR	0xAE	No active authentication with <a href="#">AppPrivacyKey</a> while enabled.
CERT_ERROR	0xCE	Active ECC-based authentication not granting <a href="#">AppPrivacyKey</a> access rights while enabled.

## 7.5 Symmetric Key management

### 7.5.1 [ChangeKey](#)

The detailed description of this command can be found in [Section 6.7.4.1](#).

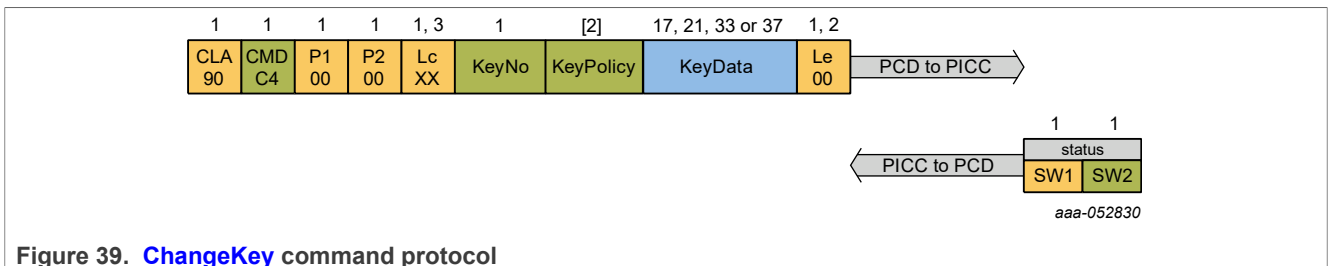

Figure 39. [ChangeKey](#) command protocol

Table 107. Command summary - [ChangeKey](#)

<a href="#">ChangeKey</a>	
Description:	This command updates a symmetric key.
CommMode:	<a href="#">CommMode.Full</a>

Table 108. Command description - [ChangeKey](#)

Name	Length	Value	Description
<b>Command Header Parameters</b>			
Cmd	1	0xC4	Command code.

Table 108. Command description - [ChangeKey](#) ...continued

Name	Length	Value	Description
KeyNo	1	-	Key number of the key to be changed.
	Bit 7-6	-	[if targeting <a href="#">AppMasterKey</a> or <a href="#">CryptoRequestKey</a> ] Key type
		10b	KeyType.AES128
		11b	KeyType.AES256
	Bit 5-0	00b	[else] RFU
		0x0..0x4	Key Number
<a href="#">AppMasterKey</a>			
0x10..0x17	<a href="#">CryptoRequestKey</a>		
KeyPolicy	[2]	-	[Optional, present if targeting <a href="#">CryptoRequestKey</a> ] Defines the allowed crypto operations with the targeted key.
	Bit 15-9	'0'	RFU
	Bit 8	-	HKDF
		'0'	disabled
		'1'	enabled
	Bit 7	-	HMAC
		'0'	disabled
		'1'	enabled
	Bit 6	-	GCM/CCM Encrypt/Sign with internal NONCE only
		'0'	disabled
		'1'	enabled
	Bit 5	-	GCM/CCM Encrypt/Sign
		'0'	disabled
		'1'	enabled
	Bit 4	-	GCM/CCM Decrypt/Verify
		'0'	disabled
		'1'	enabled
	Bit 3	-	ECB/CBC Encrypt
		'0'	disabled
		'1'	enabled
	Bit 2	-	ECB/CBC Decrypt
		'0'	disabled
		'1'	enabled
	Bit 1	-	MAC Sign
'0'		disabled	
'1'		enabled	

Table 108. Command description - [ChangeKey](#) ...continued

Name	Length	Value	Description
	Bit 0	-	MAC Verify
		'0'	disabled
		'1'	enabled
<b>Command Data Parameters</b>			
KeyData	17, 21, 33, 37		New key data.
		full range (17/33-byte length)	[targeting <a href="#">CryptoRequestKey</a> or <a href="#">AppMasterKey</a> ] NewKey    KeyVer
		full range (21/37-byte length)	[targeting <a href="#">AppKey</a> different from <a href="#">AppMasterKey</a> ] (NewKey XOR OldKey)    KeyVer    CRC32NK <sup>[1]</sup>

[1] The CRC32NK is the 4-byte CRC value computed according to IEEE Std 802.3-2008 (FCS Field) over NewKey [11]

Table 109. Response description - [ChangeKey](#)

Name	Length	Value	Description
SW1SW2	2	0x9100 0x91XX	successful execution Refer to <a href="#">Table 110</a>

Table 110. Error code description - [ChangeKey](#)

Status	Value	Description
COMMAND_ABORTED	0xCA	Chained command or multiple pass command ongoing.
INTEGRITY_ERROR	0x1E	Integrity error in cryptogram or invalid secure messaging MAC ( Secure Messaging).
LENGTH_ERROR	0x7E	Command size not allowed.
PARAMETER_ERROR	0x9E	Parameter value not allowed.
NO_SUCH_KEY	0x40	Targeted key does not exist
PERMISSION_DENIED	0x9D	Not allowed at PICC level.
PERMISSION_DENIED	0x9D	Not allowed to set both HMAC-related (bit 8-7) and AES-related (bit 6-0) bits in the KeyPolicy.
AUTHENTICATION_ERROR	0xAE	At application level, missing active authentication with <a href="#">AppMasterKey</a> while targeting any <a href="#">AppKey</a> .
AUTHENTICATION_ERROR	0xAE	At application level, missing active authentication granting <a href="#">Set Configuration</a> Option 0x15 ChangeAC access rights while targeting any <a href="#">CryptoRequestKey</a> .
CERT_ERROR	0xCE	Active ECC-based authentication not granting <a href="#">AppMasterKey</a> while targeting any <a href="#">AppKey</a> .
CERT_ERROR	0xCE	Active ECC-based authentication not granting <a href="#">SetConfiguration</a> Option 0x15 ChangeAC access rights while targeting any <a href="#">CryptoRequestKey</a> .

7.5.2 [GetKeySettings](#)

The detailed description of this command can found in [Section 6.7.4.2](#).

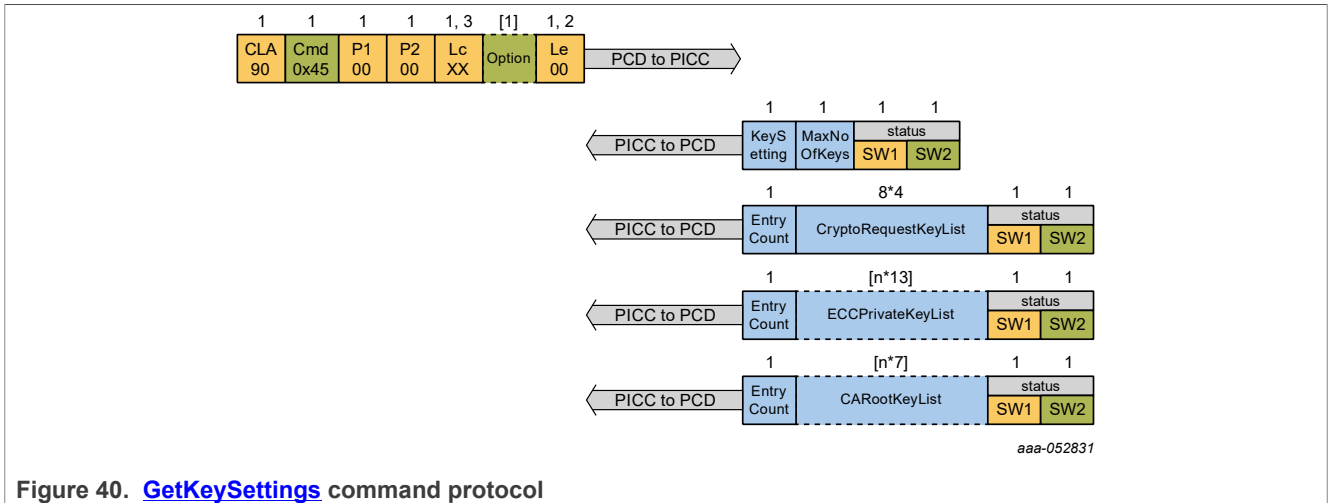

Figure 40. [GetKeySettings](#) command protocol

Table 111. Command Description - [GetKeySettings](#)

GetKeySettings	
Description:	This command retrieves the meta-data of certain key types.
CommMode:	<a href="#">CommMode.MAC</a>

Table 112. Command description - [GetKeySettings](#)

Name	Length	Value	Description
<b>Command Header Parameters:</b>			
Cmd	1	0x45	Command code.
Option	[1]	-	
		0x00	<a href="#">CryptoRequestKeys</a> meta-data
		0x01	<a href="#">ECCPrivateKey</a> meta-data
		0x02	<a href="#">CARootKeys</a> meta-data
<b>Command Data Parameters:</b>			
-	-	-	No data parameters:

Table 113. Response description - GetKeySettings - [No Option byte provided]

Name	Length	Value	Description
KeySetting	1	0x03	Reserved
MaxNoOfKeys	Bit 7-6	-	Maximum number of keys which can be stored within the selected application. Additionally the key type is returned.
			Key type
		00b	Reserved
		01b	Reserved
		10b	KeyType.AES128
		11b	KeyType.AES256
	Bit 5-0		Number of keys
	0x05	Number of application keys.	
SW1SW2	2	0x9100 0x91XX	successful execution Refer to <a href="#">Table 117</a> .

Table 114. Response description - GetKeySettings - [Option = 0x00] [CryptoRequestKey](#)'s meta-data

Name	Length	Value	Description
EntryCount	1	0x08	Number of key information entries (n) that will follow.
CryptoRequestKey List	8 × 4	-	List with meta-data
		Entry[0]	KeyNo
		Entry[1]	KeyType: KeyType.AES128 or KeyType.AES256.
		Entry[2..3]	KeyPolicy, see <a href="#">ChangeKey</a> .
SW1SW2	2	0x9100 0x91XX	successful execution Refer to <a href="#">Table 117</a> .

Table 115. Response description - GetKeySettings - [Option = 0x01] [ECCPrivateKey](#)'s meta-data

Name	Length	Value	Description
EntryCount	1	0x00..0x05	Number of key information entries (n) that will follow.
ECCPrivateKeyList	[n*13]	-	List with meta-data, see <a href="#">ManageKeyPair</a> .
		Entry[0]	KeyNo
		Entry[1]	CurveID
		Entry[2..3]	KeyPolicy
		Entry[4]	WriteAccess
		Entry[5..8]	KeyUsageCtrLimit
		Entry[9..12]	KeyUsageCtr
SW1SW2	2	0x9100 0x91XX	successful execution Refer to <a href="#">Table 117</a> .

Table 116. Response description - GetKeySettings - [Option = 0x02] CARootKey's meta-data

Name	Length	Value	Description
EntryCount	1	0x00..0x05	Number of key information entries (n) that will follow.
CARootKeyList	[n*7]	-	List with meta-data, see <a href="#">ManageCARootKey</a> .
		Entry[0]	KeyNo
		Entry[1]	CurveID
		Entry[2..3]	AccessRights
		Entry[4]	WriteAccess
		Entry[5]	Reserved
		Entry[6]	Reserved
SW1SW2	2	0x9100 0x91XX	successful execution Refer to <a href="#">Table 117</a> .

Table 117. Error code description - GetKeySettings

Status	Value	Description
COMMAND_ABORTED	0xCA	Chained command or multiple pass command ongoing.
INTEGRITY_ERROR	0x1E	Invalid secure messaging MAC
LENGTH_ERROR	0x7E	Command size not allowed.
PARAMETER_ERROR	0x9E	Parameter value not allowed.
PERMISSION_DENIED	0x9D	Option different from 0x01 not supported at PICC level.
AUTHENTICATION_ERROR	0xAE	No active authentication with <a href="#">AppMasterKey</a> .
CERT_ERROR	0xCE	Active ECC-based authentication not granting <a href="#">AppMaster Key</a> access rights.

7.5.3 [GetKeyVersion](#)

The detailed description of this command can found in [Section 6.7.4.3](#).

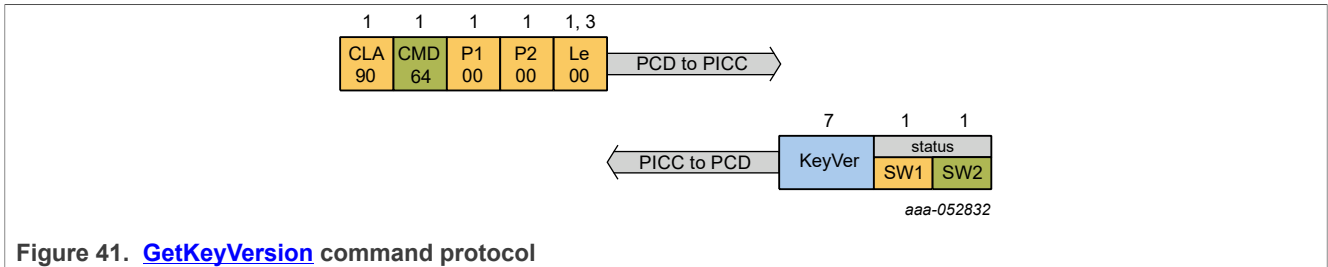

Figure 41. [GetKeyVersion](#) command protocol

Table 118. Command Description - [GetKeyVersion](#)

<a href="#">GetKeyVersion</a>	
Description:	This command retrieves the key version of the key targeted.
CommMode:	<a href="#">CommMode.MAC</a>

Table 119. Command parameters description - [GetKeyVersion](#)

Name	Length	Value	Description
<b>Command Header Parameters</b>			
Cmd	1	0x64	Command code.
KeyNo	1	-	Key number of the targeted key
	Bit 7-6	'00'	RFU
	Bit 5-0	0x0..0x4	<a href="#">AppKey</a>
		0x10..0x17	<a href="#">CryptoRequestKey</a>
<b>Command Data Parameters</b>			
-	-	-	No data parameters

Table 120. Response description - [GetKeyVersion](#)

Name	Length	Value	Description
KeyVer	1	Full range	Key version of the targeted key
SW1SW2	2	0x9100 0x91XX	successful execution Refer to <a href="#">Table 121</a>

Table 121. Error code description - [GetKeyVersion](#)

Status	Value	Description
COMMAND_ABORTED	0xCA	Chained command or multiple pass command ongoing.
INTEGRITY_ERROR	0x1E	Invalid secure messaging MAC (only).
LENGTH_ERROR	0x7E	Command size not allowed.
PARAMETER_ERROR	0x9E	Parameter value not allowed.

Table 121. Error code description - [GetKeyVersion](#) ...continued

Status	Value	Description
PERMISSION_DENIED	0x9D	Not supported at PICC level
NO_SUCH_KEY	0x40	Targeted key does not exist.

## 7.6 Asymmetric Key Management

### 7.6.1 ManageKeyPair

The detailed description of this command can be found in [Section 6.8.1.1](#).

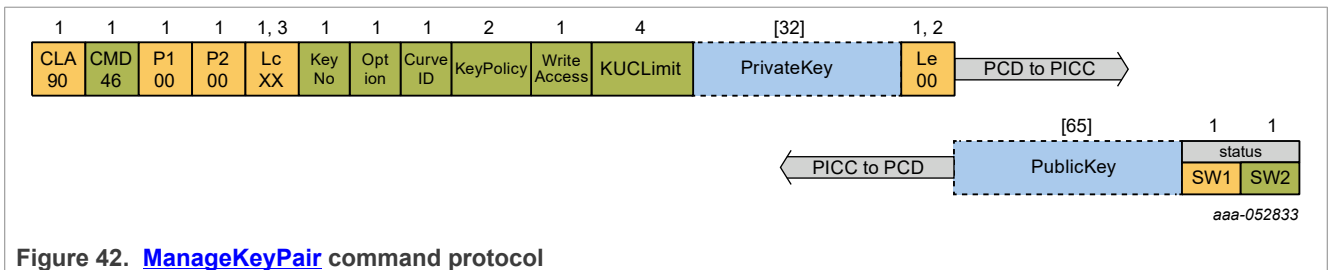

Figure 42. [ManageKeyPair](#) command protocol

Table 122. [ManageKeyPair](#)

<a href="#">ManageKeyPair</a>	
Description:	Creates or updates a private key entry by generating a key pair or importing a private key.
CommMode:	CommMode of targeted key, or if targeting not yet existing key, default CommMode of the command as defined by <a href="#">SetConfiguration</a> 0x12.

Table 123. Command Description - [ManageKeyPair](#)

Name	Length	Value	Description
<b>Command Header Parameters</b>			
CMD	1	0x46	Command code.
KeyNo	1	-	Key number of the key to be managed.
	Bit 7-3	'00000'	RFU
	Bit 2-0	-	KeyNo
		0x0..0x4	Up to five keys are supported
Option	1	-	Targeted action
		0x00	Generate Key Pair
		0x01	Import Private Key
		0x02	Update metadata
CurveID	1	-	Targeted curve
		0x0C	NIST P-256
		0x0D	brainpoolP256r1

Table 123. Command Description - [ManageKeyPair](#) ...continued

Name	Length	Value	Description
KeyPolicy	2	-	Defines the allowed crypto operations with the targeted key.
	Bit 15	-	Freeze KeyUsageCtrLimit
		'0'	disabled
		'1'	enabled
	Bit 14- 9	'000000'	RFU
	Bit 8	-	ECC-based Card-Unilateral Authentication with <a href="#">ISOInternal Authenticate</a>
		'0'	disabled
		'1'	enabled
	Bit 7-6	'00'	Reserved
	Bit 5	-	ECC-based Secure Dynamic Messaging
		'0'	disabled
		'1'	enabled
	Bit 4	-	<a href="#">CryptoRequest</a> ECC Sign (Action 0x03)
		'0'	disabled
		'1'	enabled
	Bit 3	-	<a href="#">CryptoRequest</a> ECC DH (Action 0x05)
		'0'	disabled
		'1'	enabled
	Bit 2	-	SIGMA-I Mutual Authentication
		'0'	disabled
	'1'	enabled	
Bit 1-0	'00'	Reserved	
WriteAccess	1	-	Defines the CommMode and access right required to update the key with <a href="#">ManageKeyPair</a>
	Bit 7-6	'00'	RFU
	Bit 5-4	-	Write CommMode (see <a href="#">Table 15</a> )
		'x0'	CommMode.Plain
		'01'	CommMode.MAC
		'11'	CommMode.Full
	Bit 3-0	-	WriteAR
		Full range	Access condition (see <a href="#">Table 18</a> )
KUCLimit	4	-	Defines the key usage limit of the targeted key.
		0x00000000	KeyUsageCtrLimit disabled
		0x00000001	KeyUsageCtrLimit enabled with the given value (LSB first).
		.. 0xFFFFFFFF	

Table 123. Command Description - [ManageKeyPair](#) ...continued

Name	Length	Value	Description
<b>Command Data Parameters</b>			
PrivateKey	[32]	Full range	[Optional, present if Option is set to 0x01] Private key to be imported

Table 124. Response description - [ManageKeyPair](#)

Name	Length	Value	Description
PublicKey -	[65]	Limited range	[Optional, present if Option is set to 0x00] Uncompressed public key: 0x04     Pub : x     Pub : y
SW1SW2	2	0x9100 0x91XX	successful execution Refer to <a href="#">Table 125</a>

Table 125. Error code description - [ManageKeyPair](#)

Status	Value	Description
COMMAND_ABORTED	0xCA	Chained command or multiple pass command ongoing.
INTEGRITY_ERROR	0x1E	Integrity error in cryptogram or invalid secure messaging MAC
LENGTH_ERROR	0x7E	Command size not allowed.
PARAMETER_ERROR	0x9E	Parameter value not allowed.
NO_SUCH_KEY	0x40	Targeting nonexisting key while trying to update metadata.
PERMISSION_DENIED	0x9D	Not allowed at PICC level.
PERMISSION_DENIED	0x9D	Targeting nonexisting key while <a href="#">ManageKeyPair</a> access condition is set to 0xF.
PERMISSION_DENIED	0x9D	Targeting existing key with its WriteAccess condition set to 0xF.
PERMISSION_DENIED	0x9D	Trying to update metadata, setting CurveID to a value different from the curve associated with the targeted key.
PERMISSION_DENIED	0x9D	Trying to enable key for both ECDH (KeyPolicy Bit 3) and ECDSA (other Key Policy Bits) operations.
PERMISSION_DENIED	0x9D	Trying to reconfigure a frozen KeyUsageCtrlLimit via updating metadata by setting Key Policy Bit 15 to '0' or KUCLimit to a different value than the currently configured KeyUsageCtrlLimit.
PERMISSION_DENIED	0x9D	Trying to import key while disabled by product configuration.
PERMISSION_DENIED	0x9D	Trying to update metadata while disabled by product configuration.
AUTHENTICATION_ERROR	0xAE	Targeting nonexisting key while <a href="#">ManageKeyPair</a> access condition is not granted while different from 0xF
AUTHENTICATION_ERROR	0xAE	Targeting existing key while the WriteAccess condition of the targeted key different from 0xF not being granted.
CERT_ERROR	0xCE	Targeting nonexisting key with an active ECC-based authentication while <a href="#">ManageKeyPair</a> access condition is not granted while different to 0xF.
CERT_ERROR	0xCE	Targeting existing key with an active ECC-based authentication while the WriteAccess condition of the targeted key different from 0xF not being granted.

Table 125. Error code description - ManageKeyPair ...continued

Status	Value	Description
OUT_OF_MEMORY_ERROR	0x0E	Insufficient free user memory available for creating new key.

7.6.2 ManageCARootKey

The detailed description of this command can be found in [Section 6.8.2.1](#).

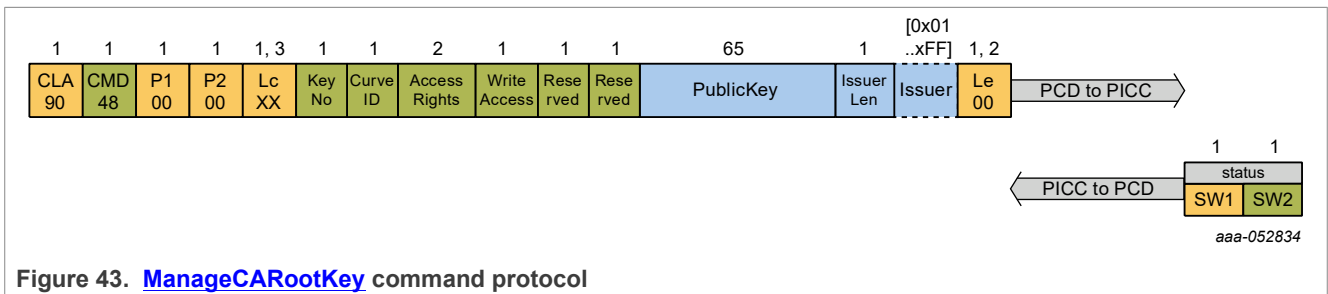

Figure 43. ManageCARootKey command protocol

Table 126. ManageCARootKey

ManageCARootKey	
Description:	Creates or updates a public key entry.
CommMode	CommMode of targeted key, or if targeting not yet existing key, default CommMode of the command as defined by <a href="#">SetConfiguration</a> 0x12.

Table 127. Command Description - ManageCARootKey

Name	Length	Value	Description	
<b>Command Header Parameters</b>				
Cmd	1	0x48	Command code.	
KeyNo	1	-	Key number of the key to be managed.	
	Bit 7-3	'00000'	RFU	
	Bit 2-0	-	KeyNo	
		0x0..0x4	Up to five keys are supported	
CurveID	1	-	Targeted curve	
		0x0C	NIST P-256	
		0x0D	brainpoolP256r1	
AccessRights	2	Limited range	Access rights associated with the <a href="#">CARootKey</a> , see <a href="#">Table 19</a> .	
WriteAccess	1	-	Defines the CommMode and access rights required to update the key with <a href="#">ManageCARootKey</a>	
		Bit 7-6	'00'	RFU
		Bit 5-4	-	Write CommMode (see <a href="#">Table 15</a> ).
			'x0'	CommMode.Plain
			'01'	CommMode.MAC
'11'	CommMode.Full			

Table 127. Command Description - ManageCARootKey ...continued

Name	Length	Value	Description
	Bit 3-0	-	WriteAR
		Full range	Access condition (see <a href="#">Table 18</a> ).
Reserved	1	0x3F	
Reserved	1	0x00	
<b>Command Data Parameters:</b>			
PublicKey	65	-	CA Public Key
		Limited range	Uncompressed public key: 0x04    Pub : x     Pub : y
IssuerLen	1	-	Length of trusted issuer name
		0x00	No trusted issuer name check required.
		0x01..0xFF	Length of Issuer.
Issuer	[0x01.. xFF]	Full range	[Optional, present if IssuerLen != 0x00] Trusted issuer name of IssuerLen bytes.

Table 128. Response description - ManageCARootKey

Name	Length	Value	Description
SW1SW2	2	0x9100 0x91XX	successful execution Refer to <a href="#">Table 129</a>

Table 129. Error code description - ManageKeyPair

Status	Value	Description
Resp.COMMAND_ABORTED	0xCA	Chained command or multiple pass command ongoing.
Resp.INTEGRITY_ERROR	0x1E	Integrity error in cryptogram or invalid secure messaging MAC
Resp.LENGTH_ERROR	0x7E	Command size not allowed.
Resp.PARAMETER_ERROR	0x9E	Parameter value not allowed.
Resp.PERMISSION_DENIED	0x9D	Not allowed at PICC level.
Resp.PERMISSION_DENIED	0x9D	Targeting nonexisting key while <a href="#">ManageCARootKey</a> access condition is set to 0xF.
Resp.PERMISSION_DENIED	0x9D	Targeting existing key with its WriteAccess condition set to 0xF.
Resp.AUTHENTICATION_ERROR	0xAE	Targeting nonexisting key while <a href="#">ManageCARootKey</a> access condition is not granted while different from 0xF.
Resp.AUTHENTICATION_ERROR	0xAE	Targeting existing key while the WriteAccess condition of the targeted key different from 0xF not being granted.
Resp.CERT_ERROR	0xCE	Targeting nonexisting key with an active ECC-based authentication while <a href="#">ManageCARootKey</a> access condition is not granted while different to 0xF.
Resp.CERT_ERROR	0xCE	Targeting existing key with an active ECC-based authentication while the WriteAccess condition of the targeted key different from 0xF not being granted.

Table 129. Error code description - ManageKeyPair ...continued

Status	Value	Description
Resp.OUT_OF_MEMORY_ERROR	0x0E	Insufficient free user memory available for creating this file.

7.6.3 GetKeySettings

See [Section 7.5.2](#).

7.7 Certificate Management

7.7.1 ManageCertRepo

The detailed description of this command's usage can be found in [Section 6.9.1](#).

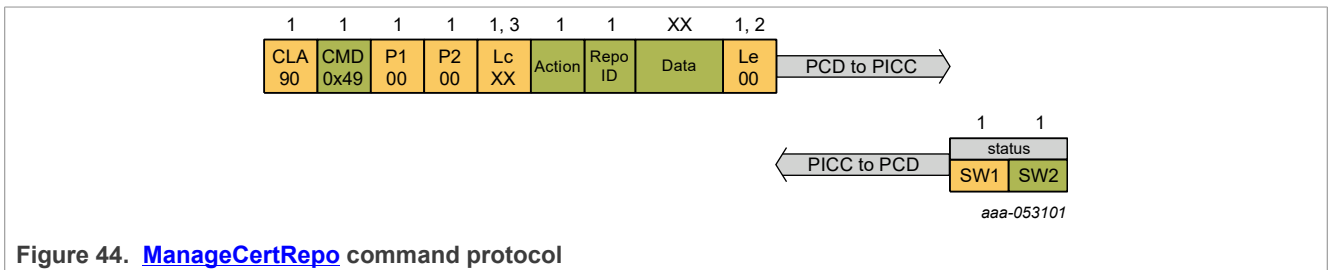

Figure 44. ManageCertRepo command protocol

<a href="#">ManageCertRepo</a>	
Description:	Manages Certificate Repositories
CommMode:	CommMode of <a href="#">ManageCertRepo</a> as defined by <a href="#">SetConfiguration</a> 0x13.

Table 130. Command Description - ManageCertRepo

Name	Length	Value	Description
<b>Command Header Parameters</b>			
CMD	1	0x49	Command code.
Command Action	1	-	The first byte of the command data specifies the action
		0x00	Create certificate repository
		0x01	Load certificate
		0x02	Load Certificate Mapping Information
		0x03	RFU
		0x04	Activate Repository
		0x05	Reset Certificate Repository
Certificate Repository Id	1	0x00 - 0x07	ID used to identify certificate repository for algorithm execution and repository modification. <b>Note:</b> The certificate Id shall be used to reference a private key/certificate chain when performing SIGMA-I

Table 130. Command Description - [ManageCertRepo](#) ...continued

Name	Length	Value	Description
Remaining Data	5	<a href="#">Table 131</a>	[if option is create certificate repository]
	6 - 691	<a href="#">Table 132</a>	[if option is load certificate]
	1 - 650	<a href="#">Table 133</a>	[if option is load certificate mapping info]
	0	-	[if option is activate certificate repository]
	2	<a href="#">Table 134</a>	[if option is reset certificate repository]

Table 131. [ManageCertRepo](#) - Create Certificate Repository

Name	Length	Value	Description
Private Key Id	1	0x00 - 0x04	ID of ECC private key associated with this repository (key must have been created using <a href="#">ManageKey Pair</a> ).
Repository Size	2	0x0001 - 0x1400	Number of bytes of NVM memory to reserve for the certificate repository
Certificate Repository Write/ Reset Access	1	-	Defines the access right required to write or reset this repository using the <a href="#">ManageCertRepo</a> command
		Bit 7-6	RFU
		Bit 5-4	CommMode, see <a href="#">Table 15</a> .
		Bit 3-0	AccessCondition Value, see <a href="#">Table 18</a> .
Certificate Repository Read Command Access	1	-	Defines the access right required to read from this repository using the ReadCertRepo command
		Bit 7-6	RFU
		Bit 5-4	CommMode, see <a href="#">Table 15</a> .
		Bit 3-0	AccessCondition Value, see <a href="#">Table 18</a> .

Table 132. [ManageCertRepo](#) - Load Certificate

Name	Length	Value	Description
Certificate Level	1	0x00	End-leaf
		0x01	Parent
		0x02	Grand-parent
Certificate	3 - 654	-	Certificate Data Bytes. The maximum length of certificate is 650 bytes. Either: 0x7f21, length, uncompressed cert Or length, compressed cert 0x99, 0x20, cert hash (only for end-leaf cert)

Table 133. [ManageCertRepo](#) - Load Certificate Mapping info

Name	Length	Value	Description
Certificate Level	1	0x00	End-leaf
		0x01	Parent
		0x02	Grand-parent
Certificate Mapping Data Length	2	0x0001 - 0x028A	
Certificate Mapping Data	1-650	-	Mapping Data

Table 134. [ManageCertRepo](#) - Reset Certificate Repository

Name	Length	Value	Description
Certificate Repository Write/ Reset Access	1	-	Defines the access right required to write or reset this repository using the <a href="#">ManageCertRepo</a> command (actions 0x01 to 0x05)
		Bit 7-6	RFU
		Bit 5-4	CommMode, see <a href="#">Table 15</a> .
		Bit 3-0	AccessCondition Value, see <a href="#">Table 18</a> .
Certificate Repository Read Command Access	1	-	Defines the access right required to read from this repository using the ReadCertRepo command
		Bit 7-6	RFU
		Bit 5-4	CommMode, see <a href="#">Table 15</a> .
		Bit 3-0	AccessCondition Value, see <a href="#">Table 18</a> .

Table 135. [ManageCertRepo](#) - Error Conditions

Status	Value	Description
Resp.COMMAND_ABORTED	0xCA	Chained command or multiple pass command ongoing.
Resp.INTEGRITY_ERROR	0x1E	MAC does not match data.
Resp.LENGTH_ERROR	0x7E	Command size not allowed. No MAC provided. Padding bytes wrong length
Resp.PARAMETER_ERROR	0x9E	Parameter value not allowed.
Resp.PERMISSION_DENIED	0x9D	Not supported at PICC level.
Resp.PERMISSION_DENIED	0x9D	Access Condition is 0xF
Resp.PERMISSION_DENIED	0x9D	Attempt to write to an activated certificate repository
Resp.PERMISSION_DENIED	0x9D	Attempt to activate a certificate repository which does not contain a leaf certificate
Resp.AUTHENTICATION_ERROR	0xAE	No active authentication granting the Access Condition while different from 0x0F
Resp.BOUNDARY_ERROR	0xBE	Attempt to write data to beyond certificate repository limits
Resp.CERT_ERROR	0xCE	Active ECC-based authentication while Access Condition not granted while different from 0xF

Table 135. [ManageCertRepo](#) - Error Conditions...continued

Status	Value	Description
Resp.DUPLICATE_ERROR	0xDE	Attempt to certificate repository, which already exists
Resp.FILE_NOT_FOUND	0xF0	Certificate repository specified does not exist
Resp.NO_SUCH_KEY	0x40	Private key specified does not exist

7.7.2 [ReadCertRepo](#)

The detailed description of this command's usage can be found in [Section 6.9.1](#).

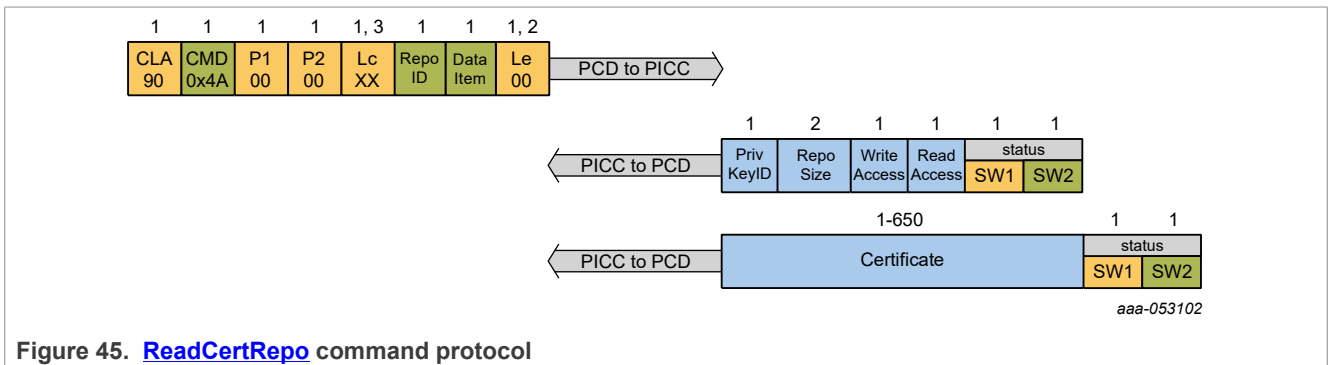

<a href="#">ReadCertRepo</a>	
Description:	Returns information related to certificate repositories
CommMode:	If reading metadata, then CommMode.MAC is applied. Reading a certificate directly from the repository requires access as defined in the Read access condition set during repository creation/reset.

Table 136. Command Description - [ReadCertRepo](#)

Name	Length	Value	Description
<b>Command Header Parameters</b>			
CMD	1	0x4A	Command code.
Certificate Repository Id	1	0x00 - 0x07	Id used to identify certificate repository
Data Item	1	0x00	End-leaf
		0x01	Parent
		0x02	Grand-parent
		0xFF	Repository metadata

Table 137. [ReadCertRepo](#) - Response Data Format for Metadata

Name	Length	Value	Description
Private Key Id	1	0x00 - 0x04	Id of ECC private key associated with this repository (key must have been created using <a href="#">ManageKeyPair</a> ).
Repository Size	2	0x01 - 0x1400	Number of bytes of NVM memory to reserve for the certificate repository

Table 137. [ReadCertRepo](#) - Response Data Format for Metadata ...continued

Name	Length	Value	Description
Certificate Repository Write/ Reset Access	1		Access required to write or reset this repository using the ManageCertRepo command
		Bit 7-6	RFU
		Bit 5-4	CommMode, see <a href="#">Table 15</a> .
		Bit 3-0	AccessCondition Value, see <a href="#">Table 18</a>
Certificate Repository Read Command Access	1		Access required to read from this repository using the <a href="#">Read CertRepo</a> command
		Bit 7-6	RFU
		Bit 5-4	CommMode, see <a href="#">Table 15</a> .
		Bit 3-0	AccessCondition Value, see <a href="#">Table 18</a> .

Table 138. [ReadCertRepo](#) - Response Data Format for Certificate

Name	Length	Value	Description
Certificate	1 - 650	-	Certificate Data Bytes

Table 139. Error Code Description - [ReadCertRepo](#)

Status	Value	Description
Resp.COMMAND_ABORTED	0xCA	Chained command or multiple pass command ongoing.
Resp.INTEGRITY_ERROR	0x1E	MAC does not match data.
Resp.LENGTH_ERROR	0x7E	Command size not allowed. No MAC provided. Padding bytes wrong length
Resp.PARAMETER_ERROR	0x9E	Parameter value not allowed.
Resp.PERMISSION_DENIED	0x9D	Not supported at PICC level.
Resp.PERMISSION_DENIED	0x9D	Access condition is 0xF
Resp.AUTHENTICATION_ERROR	0xAE	No active authentication granting the Access Condition while different from 0xF and not requesting metadata
Resp.CERT_ERROR	0xCE	Active ECC-based authentication while Access Condition not granted while different from 0xF and not requesting metadata
Resp.FILE_NOT_FOUND	0xF0	Certificate repository specified does not exist
Resp.CERT_NOT_FOUND	0xC0	Certificate does not exist in the certificate repository

7.8 File Management

7.8.1 [CreateStdDataFile](#)

The detailed description of this command can be found in [Section 6.11.4.1](#).

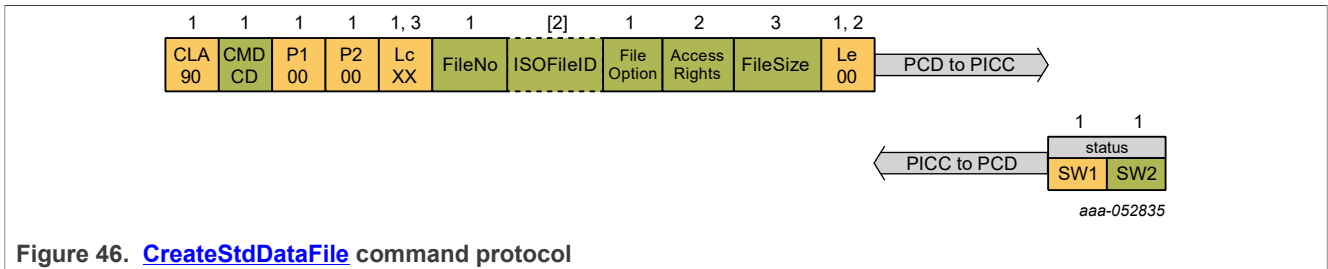

Figure 46. [CreateStdDataFile](#) command protocol

Table 140. Command Description - [CreateStdDataFile](#)

<a href="#">CreateStdDataFile</a>	
Description:	Creates files for the storage of plain unformatted user data.
CommMode:	<a href="#">CommMode.MAC</a>

Table 141. Command description - [CreateStdDataFile](#)

Name	Length	Value	Description
<b>Command Header Parameters:</b>			
Cmd	1	0xCD	Command code.
FileNo	1	-	File number of the file to be created.
	Bit 7		Second Application Indicator
		0b	Target primary application
	1b	Target secondary application	
Bit 6-5		RFU	
Bit 4-0		File number	
ISOFileID	[2]	-	[Optional] ISO/IEC 7816-4 File ID for the file to be created.
		Full Range	Excluding the following values reserved by ISO: 0x0000, 0x3F00, 0x3FFF, 0xFFFF.
FileOption	1	-	Options for the targeted file.
	Bit 7		Additional Access Rights
		0b	disabled
	1b	enabled	
	Bit 6	-	Secure Dynamic Messaging and Mirroring
		0b	disabled
1b	enabled		
Bit 5-2	0000b	RFU	

Table 141. Command description - [CreateStdDataFile...continued](#)

Name	Length	Value	Description
	Bit 1-0	-	CommMode (see Table CommunicationModes)
		x0b	<a href="#">CommMode.Plain</a>
		01b	<a href="#">CommMode.MAC</a>
		11b	<a href="#">CommMode.Full</a>
AccessRights	2	-	Set of access conditions for the 1st set in the file (see Setaccessconditions Table).
FileSize	3	-	File size in bytes for the file to be created.
		0x00001 .. 0xFF FFFF	Empty file not allowed.
<b>Command Data Parameters:</b>			
-	-	-	No data parameters

Table 142. Response description - CreateStdDataFile

Name	Length	Value	Description
SW1SW2	2	0x9100 0x91XX	successful execution Refer to <a href="#">Table 143</a>

Table 143. Error code description - CreateStdDataFile

Status	Value	Description
COMMAND_ABORTED	0xCA	Chained command or multiple pass command ongoing.
INTEGRITY_ERROR	0x1E	Invalid secure messaging MAC.
LENGTH_ERROR	0x7E	Command size not allowed.
		ISO/IEC 7816-4 File ID is enabled for the targeted application but not present in the received command.
PARAMETER_ERROR	0x9E	Parameter value not allowed.
		Targeted key for one of the access conditions in <a href="#">CreateStdDataFile.AccessRights</a> does not exist.
PERMISSION_DENIED	0x9D	Not supported at PICC level.
		SAI given but no 2nd application selected.
		Trying to pre-enable SDM on File 0x1F.
		Trying to pre-enable SDM while the application is not of Key- Type.AES.
AUTHENTICATION_ERROR	0xAE	No active authentication with <a href="#">AppMasterKey</a> while required by AppKeySettings.
DUPLICATE_ERROR	0xDE	File with the targeted <a href="#">CreateStdDataFile.FileNo</a> or <a href="#">CreateStdDataFile.ISOFileID</a> already exists.

Table 143. Error code description - CreateStdDataFile...continued

Status	Value	Description
OUT_OF_MEMORY_ERROR	0x0E	Conventional application: insufficient free user memory available for creating this file.
		Delegated application: QuotaLimit of targeted delegated application exceeded if creating this file.
MEMORY_ERROR	0xEE	Failure when reading or writing to nonvolatile memory.

7.8.2 CreateCounterFile

The detailed description of this command can be found in [Section 6.11.4.2](#).

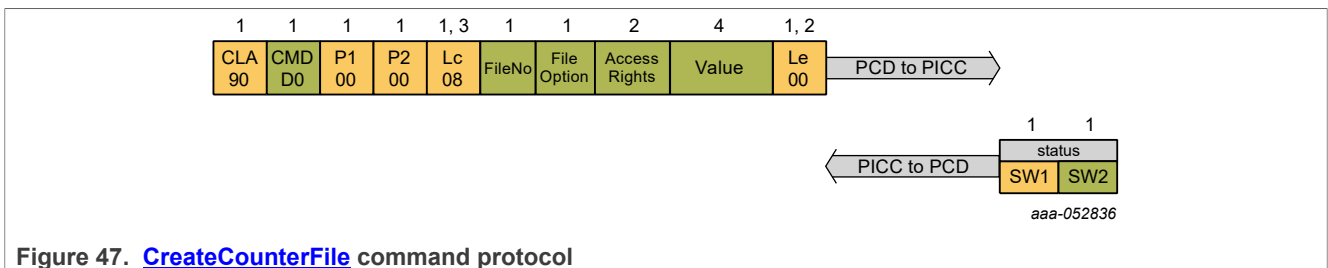

Figure 47. CreateCounterFile command protocol

Table 144. CreateCounterFile

CreateCounterFile	
Description:	Creates a Counter File.
CommMode:	<a href="#">CommMode.MAC</a>

Table 145. Command Description - CreateCounterFile

Name	Length	Value	Description
<b>Command Header Parameters</b>			
CMD	1	0xD0	Command code.
FileNo	1	-	File number of the file to be created.
	Bit 7	'0'	Reserved
	Bit 6-5	'00'	RFU
	Bit 4-0	Full Range	File number
FileOption	1	-	Options for the targeted file
	Bit 7-2	'000000'	RFU
	Bit 1-0	-	CommMode (see <a href="#">Table 15</a> )
		'X0'	CommMode.Plain
	'01'	CommMode.MAC	
	'11'	CommMode.Full	
AccessRights	2	Limited range	Set of access conditions (see <a href="#">Table 18</a> ).
Value	4	Full Range	Current Value

Table 146. Response description - [CreateCounterFile](#)

Name	Length	Value	Description
SW1SW2	2	0x9100 0x91XX	successful execution Refer to <a href="#">Table 147</a>

Table 147. Error code description - [CreateCounterFile](#)

Status	Value	Description
Resp.COMMAND_ABORTED	0xCA	Chained command or multiple pass command ongoing.
Resp.INTEGRITY_ERROR	0x1E	Invalid secure messaging MAC.
Resp.LENGTH_ERROR	0x7E	Command size not allowed.
Resp.PARAMETER_ERROR	0x9E	Parameter value not allowed.
Resp.PERMISSION_DENIED	0x9D	Parameter value not configured for ActivateConfiguration or already activated.
Resp.PERMISSION_DENIED	0x9D	Trying to create FileType.Counter while disabled by product configuration.
Resp.AUTHENTICATION_ERROR	0xAE	No active authentication with <a href="#">AppMasterKey</a> .
Resp.CERT_ERROR	0xCE	Active ECC-based authentication not granting <a href="#">AppMasterKey</a> access rights.
Resp.DUPLICATE_ERROR	0xDE	File with the targeted FileNo already exists.
Resp.OUT_OF_MEMORY_ERROR	0x0E	Insufficient free user memory available for creating this file.

### 7.8.3 [GetFileIDs](#)

The detailed description of this command can be found in [Section 6.11.3.3](#).

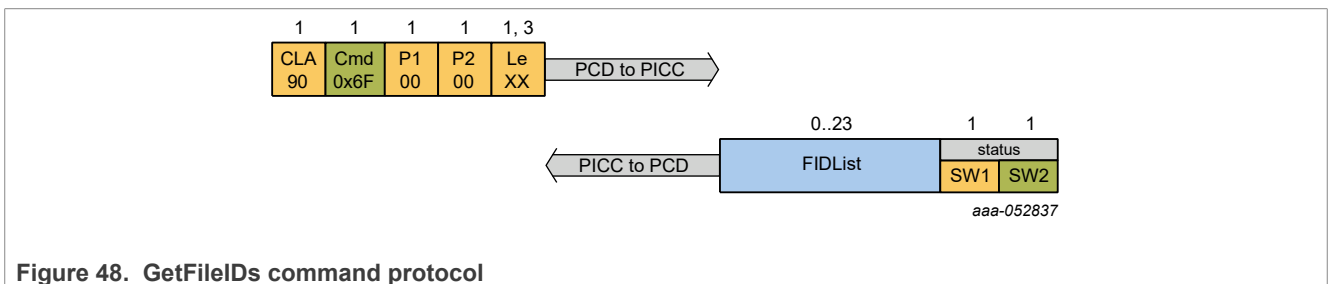

Figure 48. [GetFileIDs](#) command protocol

Table 148. Command Description - [GetFileIDs](#)

<a href="#">GetFileIDs</a>	
Description:	Returns the File IDentifiers of all active files within the currently selected application.
CommMode:	<a href="#">CommMode.MAC</a>

Table 149. Command description - [GetFileIDs](#)

Name	Length	Value	Description
<b>Command Header Parameters:</b>			
Cmd	1	0x6F	Command code.

Table 149. Command description - [GetFileIDs](#)...continued

Name	Length	Value	Description
<b>Command Data Parameters:</b>			
-	-	-	No data parameters

Table 150. Response description - [GetFileIDs](#)

Name	Length	Value	Description
FIDList	0..32	-	List of n File IDs
SW1SW2	2	0x9100 0x91XX	successful execution Refer to <a href="#">Table 151</a>

Table 151. Error code description - [GetFileIDs](#)

Status	Value	Description
COMMAND_ABORTED	0xCA	Chained command or multiple pass command ongoing.
INTEGRITY_ERROR	0x1E	Invalid secure messaging MAC.
LENGTH_ERROR	0x7E	Command size not allowed.
PARAMETER_ERROR	0x9E	Parameter value not allowed.
PERMISSION_DENIED	0x9D	Not supported at PICC level.
AUTHENTICATION_ERROR	0xAE	No active authentication with <a href="#">AppMasterKey</a> while required from AppKeySettings.
MEMORY_ERROR	0xEE	Failure when reading or writing to nonvolatile memory.

7.8.4 [GetISOFileIDs](#)

The detailed description of this command can be found in [Section 6.11.3.4](#).

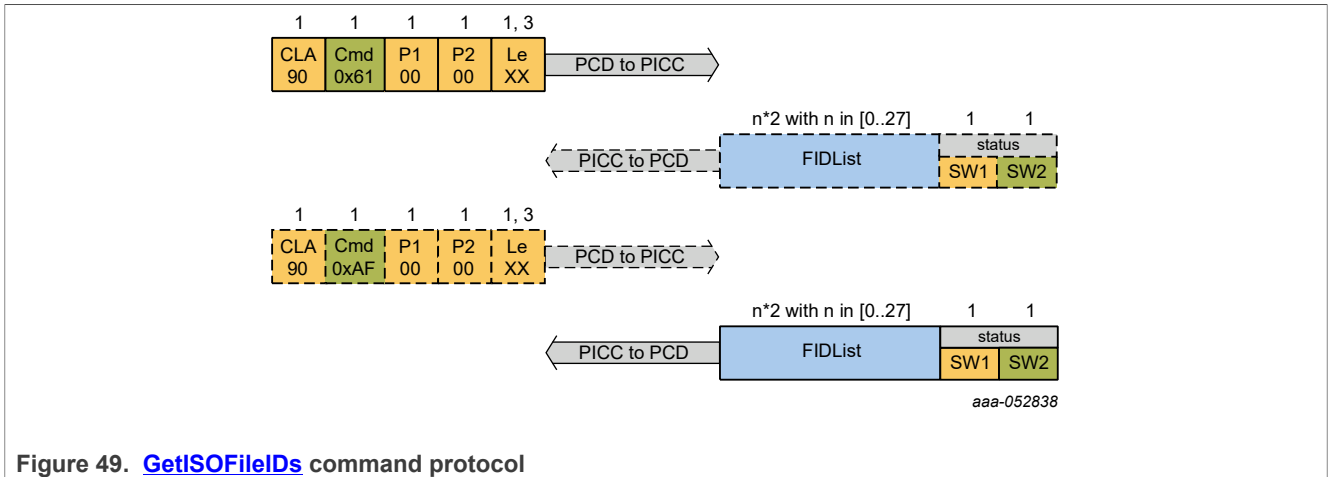

Figure 49. [GetISOFileIDs](#) command protocol

Table 152. Command Description - [GetISOFileIDs](#)

<a href="#">GetISOFileIDs</a>	
Description:	Get back the ISO File IDs.
CommMode:	<a href="#">CommMode.MAC</a>

Table 153. Command description - [GetISOFileIDs](#)

Name	Length	Value	Description
Command Header Parameters:			
Cmd	1	0x61	Command code.
Command Data Parameters:			
-	-	-	No data parameters:

Table 154. Response description - [GetISOFileIDs](#)

Name	Length	Value	Description
FIDList	n*2 with n in [0..27]	-	List of n ISO File IDs.
SW1SW2	2	0x91AF	successful execution - more data expected. Command chaining is only applied if the list does not fit into one response frame. In this case, the list is split between two ISO File IDs, i.e. never a partial ISO File ID is sent.
		0x9100	successful execution
		0x91XX	Refer to <a href="#">Table 155</a>

Table 155. Error code description - [GetISOFileIDs](#)

Status	Value	Description
COMMAND_ABORTED	0xCA	Chained command or multiple pass command ongoing.
INTEGRITY_ERROR	0x1E	Invalid secure messaging MAC.
LENGTH_ERROR	0x7E	Command size not allowed.
PARAMETER_ERROR	0x9E	Parameter value not allowed.
PERMISSION_DENIED	0x9D	Not supported at PICC level.
FILE_NOT_FOUND	0xF0	Application was created with ISO/IEC 7816-4 file identifiers disabled.
AUTHENTICATION_ERROR	0xAE	No active authentication with <a href="#">AppMasterKey</a> while required from <a href="#">AppKeySettings</a> .
MEMORY_ERROR	0xEE	Failure when reading or writing to nonvolatile memory.

7.8.5 [GetFileSettings](#)

The detailed description of this command can be found in [Section 6.11.3.1](#).

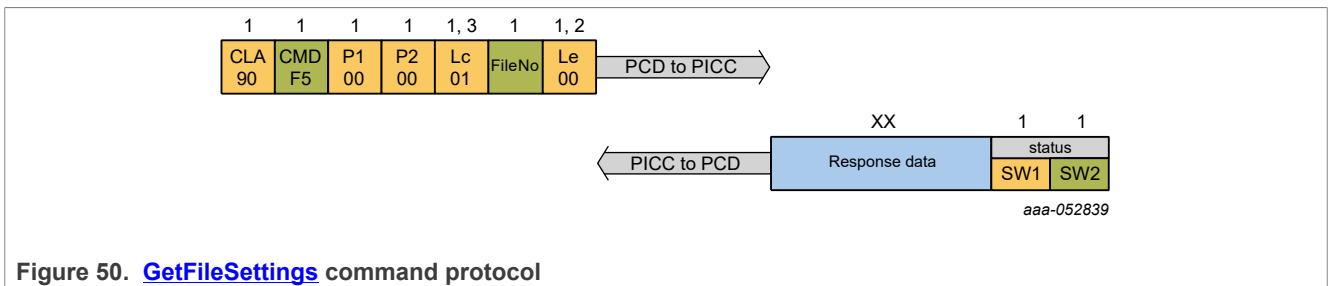

Figure 50. [GetFileSettings](#) command protocol

Table 156. Command Description - [GetFileSettings](#)

<a href="#">GetFileSettings</a>	
Description:	Get information on the properties of a specific file.
CommMode:	<a href="#">CommMode.MAC</a>

Table 157. Command description - [GetFileSettings](#)

Name	Length	Value	Description
<b>Command Header Parameters</b>			
Cmd	1	0xF5	Command code.
FileNo	1	-	File number of the targeted file.
	Bit 7-5		RFU
	Bit 4-0		File number
<b>Command Data Parameters</b>			
-	-	-	No data parameters

Table 158. Response description - [GetFileSettings](#) - Targeting FileType.StandardData

Name	Length	Value	Description
FileType	1	-	File Type of the targeted file.
		0x00	StandardData File
		Other values	RFU
FileOption	1	-	Options for the targeted file.
	Bit 7		RFU
	Bit 6	-	Secure Dynamic Messaging and Mirroring
		0b	disabled
		1b	enabled
	Bit 5-4	00b	RFU
	Bit 3	-	Deferred Configuration
		0b	disabled
		1b	enabled
	Bit 2	0b	RFU
Bit 1-0		CommMode (see <a href="#">Table 15</a> )	
AccessRights	2	-	Set of access conditions for the 1st set in the file (see <a href="#">Section 6.11.2</a> ).
FileSize	3	-	File size of the targeted file.
SDMOptions	[1]	-	[Optional, present if FileOption[Bit 6] set] SDM Options, see <a href="#">Table 167</a>
SDMAccessRights	[2]	-	[Optional, present if FileOption[Bit 6] set] SDM Access Rights, see <a href="#">Table 167</a>
UIDOffset	[3]	-	[Optional, present if ((SDMOptions[Bit 7] = 1b) AND (SDMMeta Read access right = 0xE))] Mirror position (LSB first) for UID, see <a href="#">Table 167</a>
SDMReadCtrOffset	[3]	-	[Optional, present if ((SDMOptions[Bit 6] = 1b) AND (SDMMeta Read access right = 0xE))] Mirror position (LSB first) for SDMReadCtr, see <a href="#">Table 167</a>
PICCDDataOffset	[3]	-	[Optional, present if SDMMetaRead access right = 0x0..0x4] Mirror position (LSB first) for encrypted PICCDData, see <a href="#">Table 167</a>
GPIOStatusOffset	[3]	-	[Optional, present if (SDMOptions[Bit 3] = 1b)] Mirror position (LSB first) for GPIOStatus, see <a href="#">Table 167</a>
SDMMACInputOffset	[3]	-	[Optional, present if SDMFileRead access right != 0xF] Offset in the file where the SDM MAC computation starts (LSB first), see <a href="#">Table 167</a>
SDMENCOffset	[3]	-	[Optional, present if ((SDMFileRead access right != 0xF) AND (SDMOptions[Bit 4] = 1b))] SDMENCFileData mirror position (LSB first), see <a href="#">Table 167</a>

Table 158. Response description - [GetFileSettings](#) - Targeting FileType.StandardData ...continued

Name	Length	Value	Description
SDMENCLength	[3]	-	[Optional, present if ((SDMFileRead access right != 0xF) AND (SDMOptions[Bit 4] = 1b))] Length of the SDMENCFileData (LSB first), see <a href="#">Table 167</a>
SDMMACOffset	[3]	-	[Optional, present if SDMFileRead access right != 0xF] SDMMAC mirror position (LSB first), see <a href="#">Table 167</a>
SDMReadCtrLimit	[3]	-	[Optional, present if SDMOptions[Bit 5] = 1b] SDMReadCtrLimit value (LSB first), see <a href="#">Table 167</a>
DeferOption	[1]		[Optional, present if FileOption[b3] is set] Deferral Option (see <a href="#">Table 167</a> )
DeferMethod	[1]		[Optional, present if FileOption[b3] is set] Deferral Method (see <a href="#">Table 167</a> )
SW1SW2	2	0x9100 0x91XX	successful execution Refer to <a href="#">Table 160</a>

Table 159. Response description - [GetFileSettings](#) - Targeting FileType.Counter

Name	Length	Value	Description
FileType	1	-	File Type of the targeted file.
		0x06	Counter File
		Other values	RFU
FileOption	1	-	Options for the targeted file.
	Bit 7-2	000000b	RFU
	Bit 1-0		CommMode (see <a href="#">Table 15</a> )
AccessRights	2	-	Set of access conditions for the 1st set in the file (see <a href="#">Section 6.11.2</a> ).
SW1SW2	2	0x9100 0x91XX	successful execution Refer to <a href="#">Table 160</a>

Table 160. Error code description - [GetFileSettings](#)

Status	Value	Description
COMMAND_ABORTED	0xCA	Chained command or multiple pass command ongoing.
INTEGRITY_ERROR	0x1E	Invalid secure messaging MAC (only).
LENGTH_ERROR	0x7E	Command size not allowed.
PARAMETER_ERROR	0x9E	Parameter value not allowed.
FILE_NOT_FOUND	0xF0	File with targeted FileNo does not exist for the targeted application.

7.8.6 [GetFileCounters](#)

The detailed description of this command can be found in [Section 6.11.3.2](#).

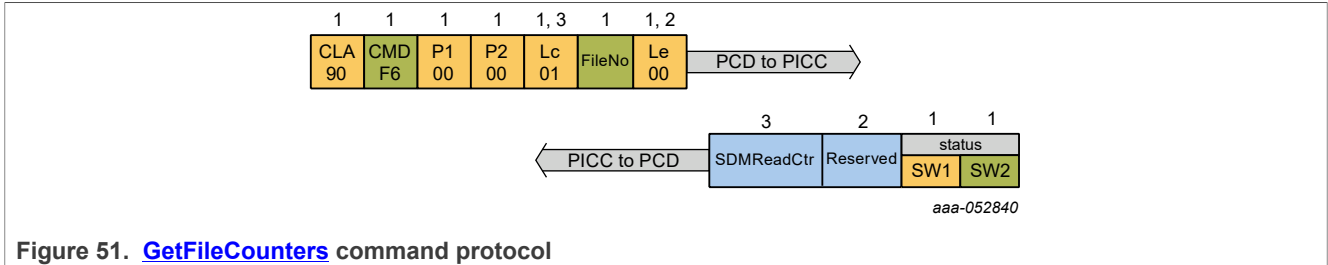

Figure 51. [GetFileCounters](#) command protocol

Table 161. Command Description - [GetFileCounters](#)

<a href="#">GetFileCounters</a>	
Description:	Get file-related counters, either used for Secure Dynamic Messaging for FileType.StandardData, or from FileType.Counter.
CommMode:	<a href="#">CommMode.Full</a> for SDMReadCtr retrieval on FileType.StandardData; CommMode of targeted file for FileType.Counter

Table 162. Command description - [GetFileCounters](#)

Name	Length	Value	Description
<b>Command Header Parameters</b>			
Cmd	1	0xF6	Command code.
FileNo	1	-	File number of the targeted file.
	Bit 7-5	000b	RFU
	Bit 4-0	Limited range	File number
<b>Command Data Parameters</b>			
-	-	-	No data parameters

Table 163. Response description - [- Targeting FileType.StandardData with SDM enabled.](#)

Name	Length	Value	Description
SDMReadCtr	3	Full Range	Current SDMReadCtr of the targeted file (LSB first).
Reserved	2	0x0000	RFU
SW1SW2	2	0x9100 0x91XX	successful execution Refer to <a href="#">Table 165</a>

Table 164. Response description - [- Targeting FileType.Counter.](#)

Name	Length	Value	Description
FileCtr	4	Full Range	The current 32-bit value (LSB first).
SW1SW2	2	0x9100 0x91XX	successful execution Refer to <a href="#">Table 165</a>

Table 165. Error code description - [GetFileCounters](#)

Status	Value	Description
COMMAND_ABORTED	0xCA	Chained command or multiple pass command ongoing
INTEGRITY_ERROR	0x1E	Invalid secure messaging MAC
LENGTH_ERROR	0x7E	Command size not allowed
PARAMETER_ERROR	0x9E	Parameter value not allowed
PERMISSION_DENIED	0x9D	PICC level (MF) is selected.
		Targeted FileType.StandardData file has no Secure Dynamic Messaging enabled.
		Targeted FileType.StandardData file has SDMctrRet access right set to 0xF.
AUTHENTICATION_ERROR	0xAE	FileAR.SDMctrRet not granted (while different from 0xF) for targeted FileType.StandardData file due to missing authentication or authentication with the wrong key
AUTHENTICATION_ERROR	0xAE	FileAR.Read or FileAR.ReadWrite not granted (while different from 0xF) for targeted FileType.Counter file due to missing authentication or authentication with the wrong key.
CERT_ERROR	0xCE	Active ECC-based authentication not granting FileAR.SDMctrRet for targeted FileType.StandardData file
CERT_ERROR	0xCE	Active ECC-based authentication not granting FileAR.Read or FileAR.Read Write for targeted FileType.Counter file
FILE_NOT_FOUND	0xF0	File with targeted FileNo does not exist for the targeted application.

7.8.7 [ChangeFileSettings](#)

The detailed description of this command can be found in [Section 6.11.2.3](#).

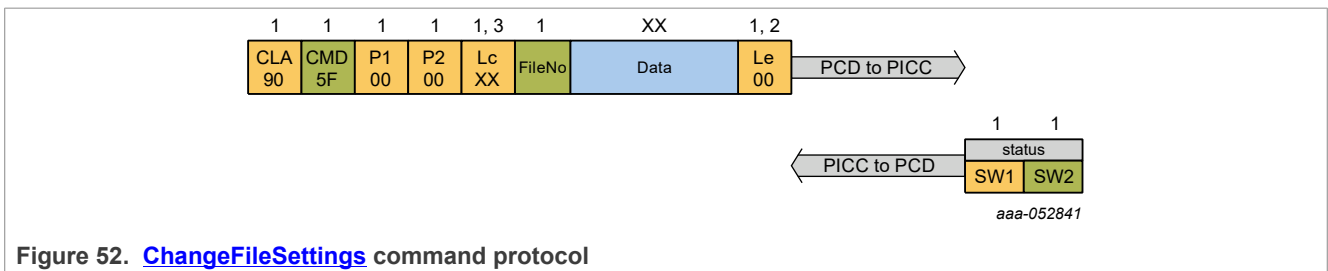

Figure 52. [ChangeFileSettings](#) command protocol

Table 166. Command summary - [ChangeFileSettings](#)

<a href="#">ChangeFileSettings</a>	
Description:	Changes the access parameters and other configurations of an existing file.
CommMode:	<a href="#">CommMode.Full</a>

Table 167. Command description - [ChangeFileSettings](#)

Name	Length	Value	Description
<b>Command Header Parameters</b>			
Cmd	1	0x5F	Command code.

Table 167. Command description - [ChangeFileSettings](#) ...continued

Name	Length	Value	Description
FileNo	1	-	File number of the targeted file.
	Bit 7-5		RFU
	Bit 4-0		File number
<b>Command Data Parameters</b>			
FileOption	1	-	Options for the targeted file.
	Bit 7	0b	RFU
	Bit 6		[if targeting FileNo 0x02] Secure Dynamic Messaging and Mirroring
		0b	disabled
		1b	enabled
	Bit 5-4	00b	RFU
	Bit 3	-	[if targeting FileNo 0x02] Deferred Configuration
		0b	disabled
		1b	enabled
	Bit 3	0b	[else] RFU
	Bit 2	0b	RFU
	Bit 1-0		CommMode (see <a href="#">Table 15</a> ).
AccessRights	2	-	Set of access conditions for the first set in the file (see <a href="#">Section 6.11.2</a> ).
SDMOptions	[1]	-	[Optional, present if FileOption[Bit 6] set] SDM Options
	Bit 7	-	UID (only for mirroring)
		0b	disabled
		1b	enabled
	Bit 6	-	SDMReadCtr
		0b	disabled
		1b	enabled
	Bit 5	-	SDMReadCtrLimit
		0b	disabled
		1b	enabled
	Bit 4	-	SDMENCFileData
		0b	disabled
		1b	enabled
	Bit 3	-	GPIOStatus
		0b	disabled
		1b	enabled

Table 167. Command description - [ChangeFileSettings](#) ...continued

Name	Length	Value	Description
	Bit 2-1	00b	RFU
	Bit 0	-	Encoding mode
		1b	ASCII
SDMAccessRights	[2]	-	[Optional, present if FileOption[Bit 6] set] SDM Access Rights
	Bit 15- 12	-	SDMMetaRead access right
		0x0..0x4	Encrypted PICCData mirroring using the targeted <a href="#">AppKey</a>
		0xE	Plain PICCData mirroring
	Bit 11- 8	0xF	No PICCData mirroring
		-	SDMFileRead access right
		0x0..0x4	Targeted <a href="#">AppKey</a>
	Bit 7-4	0xF	No symmetric SDM for Reading
		-	SDMFileRead2 access right
		0x0..0x4	Targeted <a href="#">ECCPrivateKey</a>
	Bit 3-0	0xF	No asymmetric SDM for Reading
		-	SDMCtrRet access right
		0x0..0x4	Targeted <a href="#">AppKey</a>
		0xE	Free
		0xF	No Access
UIDOffset	[3]	-	[Optional, present if ((SDMOptions[Bit 7] = 1b) AND (SDMMetaRead access right = 0xE)) Mirror position (LSB first) for UID
		0x0 .. (FileSize - UIDLength)	Offset within the file
SDMReadCtrOffset	[3]	-	[Optional, present if ((SDMOptions[Bit 6] = 1b) AND (SDMMetaRead access right = 0xE)) Mirror position (LSB first) for SDMReadCtr
		0x0 .. (FileSize - SDMRead CtrLength)	Offset within the file
		0xFFFFFFFF	No SDMReadCtr mirroring
PICCDataOffset	[3]	-	[Optional, present if SDMMetaRead access right = 0x0..0x4] Mirror position (LSB first) for encrypted PICCData
		0x0 .. (FileSize - PICCData Length)	Offset within the file

Table 167. Command description - [ChangeFileSettings](#) ...continued

Name	Length	Value	Description
GPIOStatusOffset	[3]	-	[Optional, present if (SDMOptions[Bit 3] = 1b)] Mirror position (LSB first) for GPIOStatus
		0x0 .. (FileSize-2)	Offset within the file
SDMMACInputOffset	[3]	-	[Optional, present if SDMFileRead access right != 0xF] Offset in the file where the SDM MAC computation starts (LSB first)
		0x0 .. (SDMMACOffset)	Offset within the file
SDMENCOffset	[3]	-	[Optional, present if ((SDMFileRead access right != 0xF) AND (SDMOptions[Bit 4] = 1b))] SDMENCFileData mirror position (LSB first)
		SDMMACInputOffset .. (SDMMACOffset - 32)	Offset within the file
SDMENCLength	[3]	-	[Optional, present if ((SDMFileRead access right != 0xF) AND (SDMOptions[Bit 4] = 1b))] Length of the SDMENCFileData (LSB first)
		32 .. (SDMMACOffset - SDMENCOffset)	Offset within the file, must be multiple of 32
SDMMACOffset	[3]	-	[Optional, present if SDMFileRead access right != 0xF] SDMMAC mirror position (LSB first)
		SDMMACInputOffset .. (File Size - 16)	[if (SDMFileRead access right != 0xF) AND (SDMOptions[Bit 4] = 0b)] Offset within the file
		(SDMENCOffset + SDMENCLength) .. (FileSize-16)	[if (SDMFileRead access right != 0xF) AND (SDMOptions[Bit 4] = 1b)] Offset within the file
SDMReadCtrlLimit	[3]	Full range	[Optional, present if SDMOptions[Bit 5] = 1b] SDMReadCtrlLimit value (LSB first)
DeferOption	[1]	-	[Optional, present if FileOption[b3] is set] Deferral Option
	Bit 7-1	'0'	RFU
	Bit 0	-	Defer SDM encryptions
		0b	disabled
1b	enabled		
DeferMethod	[1]	-	[Optional, present if FileOption[b3] is set] Deferral Method
		0x01..0x07	Number of boots (i.e. first ISO/IEC 14443-4 command)
		0xFF	<a href="#">ActivateConfiguration</a>
		0x00	No deferral (expected value if DeferOption is 0x00).

Table 168. Response description - [ChangeFileSettings](#)

Name	Length	Value	Description
SW1SW2	2	0x9100 0x91XX	successful execution Refer to <a href="#">Table 169</a>

Table 169. Error code description - [ChangeFileSettings](#)

Status	Value	Description
COMMAND_ABORTED	0xCA	Chained command or multiple pass command ongoing.
INTEGRITY_ERROR	0x1E	Integrity error in cryptogram. Invalid Secure Messaging MAC (only).
LENGTH_ERROR	0x7E	Command size not allowed.
PARAMETER_ERROR	0x9E	Parameter value not allowed.  Targeted key for one of the access conditions in AccessRights or SDMAccess Rights does not exist.  Targeted key for FileAR.SDMMetaRead or FileAR.SDMFileRead is not an existing symmetric key.  Targeted <a href="#">ECCPrivateKey</a> for FileAR.SDMFileRead2 is not existing or not enabled for ECC-based SDM.  Trying to set FileAR.SDMMetaRead to a value different than 0xF, while both UID and SDMReadCtr mirroring are disabled.  Trying to set FileAR.SDMMetaRead to 0xF, while enabling UID mirroring.  Trying to set FileAR.SDMCtrRet to a value different from 0xF, while SDMReadCtr is disabled.  SDMMAC and UID mirroring are overlapping, i.e. the following condition is not satisfied: $(SDMMACOffset \geq UIDOffset + UIDLength)$ OR $(UIDOffset \geq SDMMACOffset + SDMMACLength)$  SDMMAC and SDMReadCtr mirroring are overlapping, i.e. the following condition is not satisfied: $(SDMMACOffset \geq SDMReadCtrOffset + SDMReadCtrLength)$ OR $(SDMReadCtrOffset \geq SDMMACOffset + SDMMACLength)$  SDMMAC and PICCData mirroring are overlapping, i.e. the following condition is not satisfied: $(SDMMACOffset \geq PICCDataOffset + PICCDataLength)$ OR $(PICCDataOffset \geq SDMMACOffset + SDMMACLength)$  SDMMAC and GPIOStatus mirroring are overlapping, i.e. the following condition is not satisfied: $(SDMMACOffset \geq GPIOStatus + 3)$ OR $(GPIOStatus \geq SDMMACOffset + SDMMACLength)$  SDMSIG and GPIOStatus mirroring are overlapping, i.e. the following condition is not satisfied: $(SDMMACOffset \geq GPIOStatus + 3)$ OR $(GPIOStatus \geq SDMMACOffset + SDMSIGLength)$  SDMSIG and UID mirroring are overlapping, i.e. the following condition is not satisfied: $(SDMMACOffset \geq UIDOffset + UIDLength)$ OR $(UIDOffset \geq SDMMACOffset + SDMSIGLength)$  SDMSIG and SDMReadCtr mirroring are overlapping, i.e. the following condition is not satisfied: $(SDMMACOffset \geq SDMReadCtrOffset + SDMReadCtrLength)$ OR $(SDMReadCtrOffset \geq SDMMACOffset + SDMSIGLength)$

Table 169. Error code description - [ChangeFileSettings](#) ...continued

Status	Value	Description
		SDMSIG and PICCData mirroring are overlapping, i.e. the following condition is not satisfied: $(SDMMACOffset \geq PICCDataOffset + PICCDataLength)$ OR $(PICCDataOffset \geq SDMMACOffset + SDMSIGLength)$
		SDMENCFileData and UID mirroring are overlapping, i.e. the following conditions is not satisfied: $(SDMENCOffset \geq UIDOffset + UIDLength)$ OR $(UIDOffset \geq SDMENCOffset + SDMENCLength)$
		SDMENCFileData and SDMReadCtr mirroring are overlapping, i.e. the following condition is not satisfied: $(SDMENCOffset \geq SDMReadCtrOffset + SDMReadCtrLength)$ OR $(SDMReadCtrOffset \geq SDMENCOffset + SDMENCLength)$
		SDMENCFileData and PICCData mirroring are overlapping, i.e. the following condition is not satisfied: $(SDMENCOffset \geq PICCDataOffset + PICCDataLength)$ OR $(PICCDataOffset \geq SDMENCOffset + SDMENCLength)$
		GPIOStatus and UID mirroring are overlapping, i.e. the following condition is not satisfied: $(GPIOStatus \geq UIDOffset + UIDLength)$ OR $(UIDOffset \geq GPIOStatus + 3)$
		GPIOStatus and SDMReadCtr mirroring are overlapping, i.e. the following condition is not satisfied: $(GPIOStatus \geq SDMReadCtrOffset + SDMReadCtrLength)$ OR $(SDMReadCtrOffset \geq GPIOStatus + 3)$
		GPIOStatus and PICCData mirroring are overlapping, i.e. the following condition is not satisfied: $(GPIOStatus \geq PICCDataOffset + PICCDataLength)$ OR $(PICCDataOffset \geq GPIOStatus + 3)$
		GPIOStatus is overlapping with SDMENCFileData without being fully part of the plain input data area, i.e. following condition is not satisfied: $(GPIOStatus + 3 \leq SDMENCOffset)$ OR $(GPIOStatus \geq SDMENCOffset + SDMENCLength)$ OR $(GPIOStatus \geq SDMENCOffset)$ AND $((GPIOStatus + 3) \leq (SDMENCOffset + SDMENCLength/2))$
		UID and SDMReadCtr mirroring are overlapping, i.e. the following condition is not satisfied: $(UIDOffset \geq SDMReadCtrOffset + SDMReadCtrLength)$ OR $(SDMReadCtrOffset \geq UIDOffset + UIDLength)$
		Enabling Secure Dynamic Messaging encryption (SDMOptions[b4] set to 1) is not possible if FileAR.SDMFileRead = 0xF.
		Enabling Secure Dynamic Messaging encryption (SDMOptions[b4] set to 1) is not allowed if not both SDMReadCtr and UID are mirrored (i.e. SDMOptions[b7] and SDMOptions[b6] must be set to 1)
		Trying to set a SDMReadCtrLimit while not enabling SDMReadCtr.
		Trying to set a SDMReadCtrLimit, which is smaller or equal to the current SDMReadCtr.
PERMISSION_DENIED	0x9D	PICC level (MF) is selected.
		access right Change of targeted file has access conditions set to 0xF.
		Enabling Secure Dynamic Messaging (FileOption Bit 6 set to 1b) is only allowed for FileNo 0x02.
		Enabling Deferred Configuration is only allowed for FileNo 0x02.
		Trying to enable GPIOStatus while GPIO support disabled by product configuration.
FILE_NOT_FOUND	0xF0	File with targeted FileNo does not exist for the targeted application.

Table 169. Error code description - [ChangeFileSettings](#) ...continued

Status	Value	Description
AUTHENTICATION_ERROR	0xAE	File access right Change of targeted file not granted as there is no active authentication with the required key while the access conditions is different from 0xF.
CERT_ERROR	0xCE	Active ECC-based authentication not granting FileAR.Change access rights.

## 7.9 Data Management

### 7.9.1 ReadData

The detailed description of this command can be found in [Section 6.12.1.1](#).

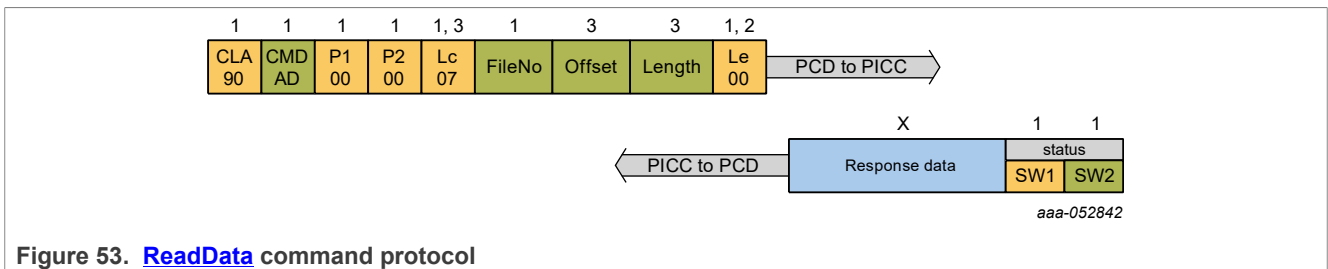

Figure 53. [ReadData](#) command protocol

Table 170. Command summary - [ReadData](#)

<a href="#">ReadData</a>	
Description:	Reads data from FileType.StandardData files.
CommMode:	CommMode of targeted file.

Table 171. Command parameters description - [ReadData](#)

Name	Length	Value	Description
<b>Command Header Parameters</b>			
Cmd	1	0xAD	Command code.
FileNo	1	-	File number of the targeted file.
	Bit 7-5	000b	RFU
	Bit 4-0		File number
		Full Range	
Offset	3	0x000000 .. (File Size - 1)	Starting position for the read operation.
Length	3	-	Number of bytes to be read.
		0x000000	Read the entire StandardData file, starting from the position specified in the offset value.
		0x000001 .. (File Size - Offset)	
<b>Command Data Parameters</b>			
-	-	-	No data parameters

Table 172. Response description - [ReadData](#)

Name	Length	Value	Description
Response data	X	Full Range	Data read from the file
SW1SW2	2	0x9100 0x91XX	successful execution Refer to <a href="#">Table 173</a>

Table 173. Error code description - [ReadData](#)

Status	Value	Description
COMMAND_ABORTED	0xCA	Chained command or multiple pass command ongoing
INTEGRITY_ERROR	0x1E	Invalid secure messaging MAC (only) SMDRdCtr overflow
LENGTH_ERROR	0x7E	Command size not allowed
PARAMETER_ERROR	0x9E	Parameter value not allowed
PERMISSION_DENIED	0x9D	Targeted file is not of FileType.StandardData. Read, ReadWrite and SDMFileRead (if SDM is enabled) access right of targeted StandardData file only have access conditions set to 0xF. Targeted file cannot be read in <a href="#">VCState.NotAuthenticated</a> as the related SDMReadCtr is equal or bigger than its SDMReadCtrLimit. Targeted FileNo 0x01 at PICC level, while Originality Check is disabled. Trying to read SDMSIG while the KeyUsageCtrLimit of the targeted key entry is enabled and reached.
FILE_NOT_FOUND	0xF0	Targeted file does not exist in the targeted application
AUTHENTICATION_ERROR	0xAE	Read, ReadWrite, and SDMFileRead (if SDM enabled) access right of targeted file not granted while at least one of the access conditions is different from 0xF.
CERT_ERROR	0xCE	Active ECC-based authentication not granting the required access rights.
BOUNDARY_ERROR	0xBE	If targeting FileType.StandardData, attempt to read beyond the file boundary.

7.9.2 WriteData

The detailed description of this command can be found in [Section 6.12.1.2](#).

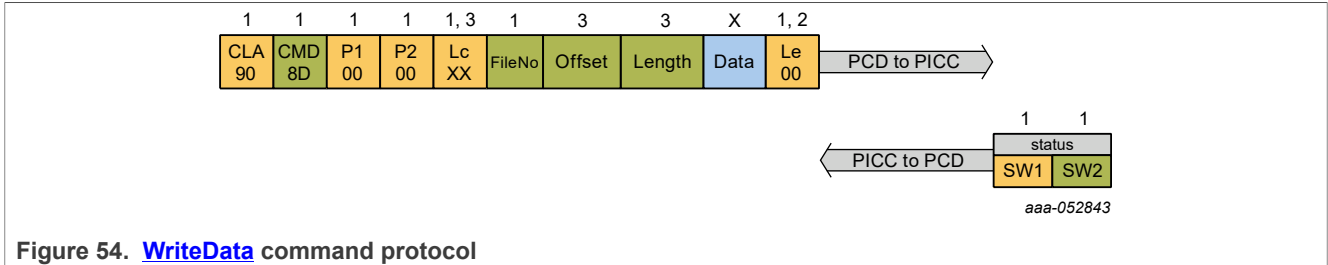

Figure 54. WriteData command protocol

Table 174. Command summary - WriteData

WriteData	
Description:	Writes data to FileType.StandardData files.
CommMode:	CommMode of targeted file.

Table 175. Command parameters description - WriteData

Name	Length	Value	Description
<b>Command Header Parameters</b>			
Cmd	1	0x8D	Command code.
FileNo	1	-	File number of the targeted file.
	Bit 7-5	000b	RFU
	Bit 4-0		File number
		Full range	
Offset	3	0x000000 .. (File Size - 1)	Starting position for the write operation.
Length	3	0x000001 .. (File Size - Offset)	Number of bytes to be written.
<b>Command Data Parameters</b>			
Data	X	Full range	Data to be written.

Table 176. Response description - WriteData

Name	Length	Value	Description
No response data parameters defined for this command			
SW1SW2	2	0x9100 0x91XX	successful execution Refer to <a href="#">Table 177</a>

Table 177. Error code description - WriteData

Status	Value	Description
COMMAND_ABORTED	0xCA	Chained command or multiple pass command ongoing.

Table 177. Error code description - [WriteData](#) ...continued

Status	Value	Description
INTEGRITY_ERROR	0x1E	Invalid secure messaging MAC or encryption padding.
LENGTH_ERROR	0x7E	Command size not allowed.
PARAMETER_ERROR	0x9E	Parameter value not allowed.
PERMISSION_DENIED	0x9D	PICC level (MF) is selected.
		Targeted file is not of FileType.StandardData.
		Write and ReadWrite of targeted file only have access conditions set to 0xF.
		Targeting a StandardData file with a chained command in MAC or Full while this is not allowed.
FILE_NOT_FOUND	0xF0	Targeted file does not exist in the targeted application.
AUTHENTICATION_ERROR	0xAE	Write and ReadWrite of targeted file not granted while at least one of the access conditions is different from 0xF.
CERT_ERROR	0xCE	Active ECC-based authentication not granting the required access rights.
BOUNDARY_ERROR	0xBE	Attempt to write beyond the file boundary as set during creation.

7.9.3 [IncrementCounterFile](#)

The detailed description of this command can be found in [Section 6.12.2.1](#).

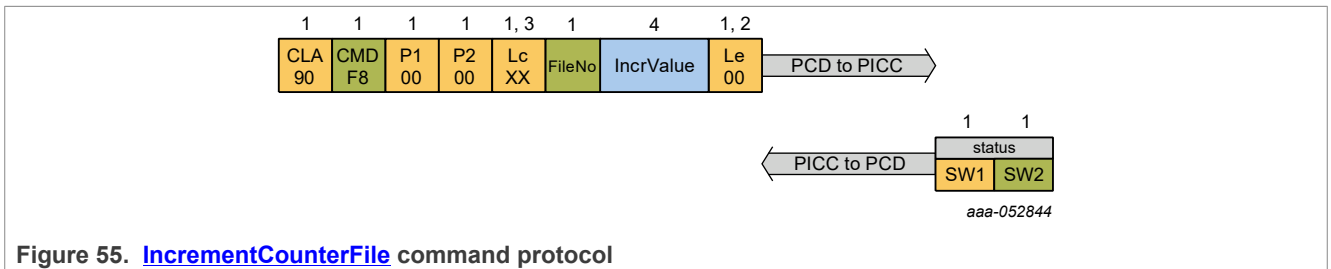

Figure 55. [IncrementCounterFile](#) command protocol

Table 178. [IncrementCounterFile](#)

<a href="#">IncrementCounterFile</a>	
Description:	Increments a Counter File.
CommMode:	CommMode of targeted file.

Table 179. Command Description - [IncrementCounterFile](#)

Name	Length	Value	Description
<b>Command Header Parameters</b>			
CMD	1	0xF8	Command code.
FileNo	1	-	File number of the file to be incremented.
	Bit 7	'0'	Reserved
	Bit 6-5	'00'	RFU
	Bit 4-0	Full Range	File number

Table 179. Command Description - [IncrementCounterFile](#) ...continued

Name	Length	Value	Description
<b>Command Data Parameters</b>			
IncrValue	4	Full Range	Value to be incremented. LSB first.

Table 180. Response description - [IncrementCounterFile](#)

Name	Length	Value	Description
No response data parameters defined for this command			
SW1SW2	2	0x9100 0x91XX	successful execution Refer to <a href="#">Table 181</a>

Table 181. Error code description - [IncrementCounterFile](#)

Status	Value	Description
Resp.COMMAND_ABORTED	0xCA	Chained command or multiple pass command ongoing.
Resp.INTEGRITY_ERROR	0x1E	Invalid secure messaging MAC.
Resp.LENGTH_ERROR	0x7E	Command size not allowed.
Resp.PARAMETER_ERROR	0x9E	Parameter value not allowed.
Resp.PERMISSION_DENIED	0x9D	Not supported at PICC level.
Resp.PERMISSION_DENIED	0x9D	Targeted file is not of FileType.Counter.
Resp.PERMISSION_DENIED	0x9D	FileAR.Write and FileAR.ReadWrite of targeted file only have access conditions set to 0xF.
Resp.FILE_NOT_FOUND	0xF0	Targeted file does not exist.
Resp.AUTHENTICATION_ERROR	0xAE	FileAR.Write and FileAR.ReadWrite of targeted file not granted while at least one of the access conditions is different from 0xF.
Resp.CERT_ERROR	0xCE	Active ECC-based authentication, but CertAccessRights are not granting the required access rights.
Resp.BOUNDARY_ERROR	0xBE	File with the targeted FileNo already exists.

7.10 Crypto API

The detailed description of the usage of this command can be found in [Section 6.13](#). The [CryptoRequest](#) restricts the maximum length of the command data to 0xFF (standard APDU), therefore, multipart command options need to be used if the input data exceeds this limit. Furthermore, the actual limit for individual command data fields may be further restricted if secure messaging must be applied.

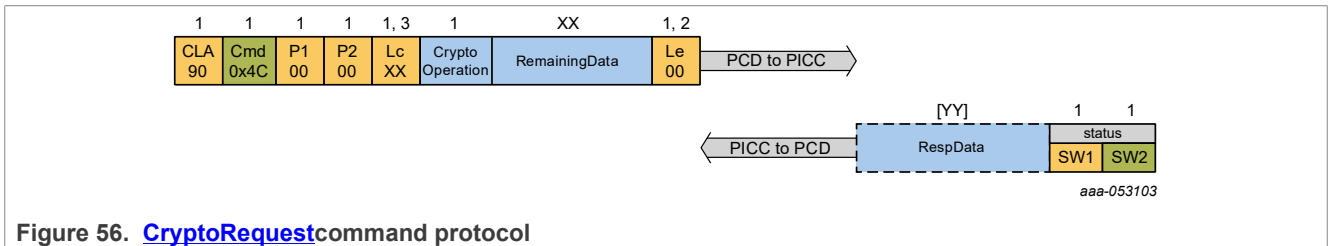

<b>CryptoRequest</b>	
Description:	Supports execution of various cryptographic algorithms
CommMode:	CommMode of <a href="#">CryptoRequest</a> as defined by <a href="#">SetConfiguration</a> 0x15.

Table 182. Command Description - [CryptoRequest](#)

Name	Length	Value	Description
<b>Command Header Parameters</b>			
CMD	1	0x4C	Command code.
<b>Command Data Parameters</b>			
Crypto Operation	1	-	The first byte of the command data specifies the operation
		0x01	SHA - for remaining command data see <a href="#">Section 7.10.1</a>
		0x02	RNG - for remaining command data see <a href="#">Section 7.10.2</a>
		0x03	ECC Sign - for remaining command data see <a href="#">Section 7.10.3</a>
		0x04	ECC Verify - for remaining command data see <a href="#">Section 7.10.4</a>
		0x05	ECC DH - for remaining command data see <a href="#">Section 7.10.5</a>
		0x06	AES Enc/Dec - for remaining command data see <a href="#">Section 7.10.6</a>
		0x07	Write Internal Buffer - for remaining command data see <a href="#">Section 7.10.9</a>
		0x08	HMAC - for remaining command data see <a href="#">Section 7.10.10</a>
		0x09	HKDF - for remaining command data see
		0x0A	AES CMAC Sign/Verify - for remaining command data see <a href="#">Section 7.10.7</a>
		0x0B	AES AEAD Encrypt/Sign - for remaining command data see <a href="#">Section 7.10.8</a>
		0x0C	AES AEAD Decrypt/Verify - for remaining command data see <a href="#">Section 7.10.8</a>
0xFD	Echo - for remaining command data see <a href="#">Section 7.10.12</a>		
Remaining Command Data	XX	-	

Table 183. Error Code Description - CryptoRequest

Status	Value	Description
Resp.COMMAND_ABORTED	0xCA	Chained command or multiple pass command ongoing.
Resp.INTEGRITY_ERROR	0x1E	MAC does not match data.
Resp.LENGTH_ERROR	0x7E	Command size not allowed. No MAC provided. Padding bytes wrong length
Resp.PARAMETER_ERROR	0x9E	Crypto Operation not valid
Resp.PARAMETER_ERROR	0x9E	Input source not valid
Resp.PARAMETER_ERROR	0x9E	Output destination not valid
Resp.PARAMETER_ERROR	0x9E	Parameter value not allowed
Resp.PERMISSION_DENIED	0x9D	Crypto API is disabled
Resp.PERMISSION_DENIED	0x9D	Not supported at PICC level.
Resp.PERMISSION_DENIED	0x9D	Update or finalize operation specified and no on-going multipart operation
Resp.PERMISSION_DENIED	0x9D	Access condition is 0xF
Resp.AUTHENTICATION_ERROR	0xAE	No active authentication granting the Access Condition while different from 0x0F
Resp.AUTHENTICATION_ERROR	0xAE	Slot policy does not permit operation
Resp.CERT_ERROR	0xCE	Active ECC-based authentication while Access Condition not granted while different from 0xF
Resp.BOUNDARY_ERROR	0xBE	Input source specified as an internal buffer and number of input bytes results in 'out of bounds' e.g. use 64 bytes from slot 5 of the TB
Resp.BOUNDARY_ERROR	0xBE	Output data does not fit output buffer

### 7.10.1 CryptoRequest SHA

It is possible to execute an SHA calculation using a single command or as a series of commands. Using multiple steps allows the input data to be taken from different sources.

Table 184. [CryptoRequest SHA](#) - SHA Init Operation

Name	Length	Value	Description
SHA Operation	1	0x01	Init operation
SHA Algorithm	1	0x01	SHA-256
		0x02	SHA-384
Input Data Source	1	<a href="#">Table 40</a>	
Input Data Length	[1]	0xXX	Length of input data, only present when the input source is an internal buffer
Input Data	[XX]	-	Input data when the input source is the command buffer

Table 185. [CryptoRequest SHA](#) - SHA Update Operation

Name	Length	Value	Description
SHA Operation	1	0x02	Update existing SHA operation
Input Data Source	1	<a href="#">Table 40</a>	
Input Data Length	[1]	0xXX	Length of input data, only present when the input source is an internal buffer
Input Data	[XX]	-	Input data when the input source is the command buffer

Table 186. [CryptoRequest SHA](#) - SHA Finalize Operation

Name	Length	Value	Description
SHA Operation	1	0x03	Finalize current SHA operation
Input Data Source	1	<a href="#">Table 40</a>	
Input Data Length	[1]	0xXX	Length of input data, only present when the input source is an internal buffer
Input Data	[XX]	-	Input data when the input source is the command buffer
Result Destination	1	<a href="#">Table 40</a>	

Table 187. [CryptoRequest SHA](#) - SHA One-Shot Operation

Name	Length	Value	Description
SHA Operation	1	0x04	One-shot operation
SHA Algorithm	1	0x01	SHA-256
		0x02	SHA-384
Input Data Source	1	<a href="#">Table 40</a>	
Input Data Length	[1]	0xXX	Length of input data, only present when the input source is an internal buffer
Input Data	[XX]	-	Input data when the input source is the command buffer
Result Destination	1	<a href="#">Table 40</a>	

Table 188. Response description - SHA Operation

Name	Length	Value	Description
Response data	[32 or 48]	-	Hash when destination is the command buffer and operation is finalize or one-shot
SW1SW2	2	0x9100 0x91XX	successful execution Refer to <a href="#">Table 183</a>

7.10.2 CryptoRequest RNG

It is possible to generate random data, which is compliant with NIST SP800-90B using a 256-bit key. The Maximum number of generated bytes is 128.

Table 189. [CryptoRequest RNG](#) - RNG Operation

Name	Length	Value	Description
Num Bytes	1	0x01 - 0x80	The number of bytes to generate
Result Destination	1	<a href="#">Table 40</a>	

Table 190. Response description - RNG Operation

Name	Length	Value	Description
Response data	[1 - 128]	-	Random data bytes if destination is the command buffer
SW1SW2	2	0x9100 0x91XX	successful execution Refer to <a href="#">Table 183</a> and <a href="#">Table 191</a>

Table 191. Error Code Description - RNG Operation

Status	Value	Description
Resp.PERMISSION_DENIED	0x9D	Number of bytes requested is invalid

7.10.3 CryptoRequest ECC\_Sign

The ECC signature generation API supports signing of a data stream or a pre-computed hash. The input may be provided in the command buffer or located in an internal buffer. The Signature shall be output to the command buffer (64 bytes of raw signature data).

Table 192. [CryptoRequest ECC\\_Sign](#) - ECC Sign Init Operation

Name	Length	Value	Description
ECC Sign Operation	1	0x01	Init operation
Algorithm	1	0x00	ECDSA with SHA-256
Private Key Id	1	0x00 - 0x04	Id of the ECC key pair containing the private key to use. Note a key pair must be marked as 'Crypto API Signature' <b>Note:</b> A key pair must be marked as 'Crypto API Signature'
Input Data Source	1	<a href="#">Table 40</a>	
Input Data Length	[1]	0xXX	Length of input data, only present when the input source is an internal buffer
Input Data	[XX]	-	Raw data bytes, only present when input source is the command buffer

Table 193. [CryptoRequest ECC\\_Sign](#) - ECC Sign Update Operation

Name	Length	Value	Description
ECC Sign Operation	1	0x02	Update data to be signed

Table 193. [CryptoRequest ECC\\_Sign](#) - ECC Sign Update Operation...continued

Name	Length	Value	Description
Input Data Source	1	<a href="#">Table 40</a>	
Input Data Length	[1]	0xXX	Length of input data, only present when the input source is an internal buffer
Input Data	[XX]	-	Raw data bytes, only present when input source is the command buffer

Table 194. [CryptoRequest ECC\\_Sign](#) - ECC Sign Finalize Operation

Name	Length	Value	Description
ECC Sign Operation	1	0x03	Finalize signature operation
Input Data Source	1	<a href="#">Table 40</a>	
Input Data Length	[1]	0xXX	Length of input data, only present when the input source is an internal buffer
Input Data	[XX]	-	Raw data bytes, only present when input source is the command buffer

Table 195. [CryptoRequest ECC\\_Sign](#) - ECC Sign One-Shot Operation

Name	Length	Value	Description
ECC Sign Operation	1	0x04	One-shot operation
Algorithm	1	0x00	ECDSA with SHA-256
Private Key Id	1	0x00 - 0x04	Id of the ECC key pair containing the private key to use. <b>Note:</b> A key pair must be marked as 'Crypto API Signature'
Input Data Source	1	<a href="#">Table 40</a>	
Input Data Length	[1]	0xXX	Length of input data, only present when the input source is an internal buffer
Input Data	[XX]	-	Raw data bytes, only present when input source is the command buffer

Table 196. [CryptoRequest ECC\\_Sign](#) - ECC Sign One-Shot Pre-computed Hash Operation

Name	Length	Value	Description
ECC Sign Operation	1	0x05	One-shot with pre-somputed hash operation
Algorithm	1	0x00	ECDSA with SHA-256
Private Key Id	1	0x00 - 0x04	Id of the ECC key pair containing the private key to use. Note a key pair must be marked as 'Crypto API Signature'
Input Data Source	1	<a href="#">Table 40</a>	
Input Data Length	[1]	0x20	Length of input data, only present when the input source is an internal buffer
Input Data	[32]	-	Hash data bytes only present when input source is the command buffer

Table 197. Response description - ECC Sign Operation

Name	Length	Value	Description
Response data	[64]	-	Signature bytes if operation is finalize or one-shot
SW1SW2	2	0x9100 0x91XX	successful execution Refer to <a href="#">Table 183</a> and <a href="#">Table 198</a>

Table 198. Error Code Description - ECC Sign Operation

Status	Value	Description
Resp.PERMISSION_DENIED	0x9D	Key id valid but key is not marked as 'Crypto API Signature'
Resp.LENGTH_ERROR	0x9D	Key usage counter limit is enabled and has been reached
Resp.LENGTH_ERROR	0x7E	Operation is one-shot with pre-computed hash and input length is not 32 bytes

#### 7.10.4 CryptoRequest ECC\_Verify

The ECC signature verification API supports verification of a data stream or data, which has already been hashed. The input may be provided in the input buffer or located in an internal buffer. The Signature to verify shall be provided in the command buffer. The signature verification successful result shall be provided as response data.

Table 199. [CryptoRequest ECC\\_Verify](#) - ECC Sign Init Operation

Name	Length	Value	Description
ECC Verify Operation	1	0x01	Init operation
Algorithm	1	0x00	ECDSA with SHA-256
Curve	1	0x0C	NIST 256
		0x0D	Brainpool 256
Host's Public Key	65	-	The public key to use for signature verification provided in uncompressed format
Input Data Source	1	<a href="#">Table 40</a>	
Input Data Length	[1]	0xXX	Length of input data, only present when the input source is an internal buffer
Input Data	[XX]	-	Raw data bytes, only present when input source is the command buffer

Table 200. [CryptoRequest ECC\\_Verify](#) - ECC Verify Update Operation

Name	Length	Value	Description
ECC Verify Operation	1	0x02	Update data to be verified
Input Data Source	1	<a href="#">Table 40</a>	
Input Data Length	[1]	0xXX	Length of input data, only present when the input source is an internal buffer

Table 200. [CryptoRequest ECC\\_Verify](#) - ECC Verify Update Operation...continued

Name	Length	Value	Description
Input Data	[XX]	-	Raw data bytes, only present when input source is the command buffer

Table 201. [CryptoRequest ECC\\_Verify](#) - ECC Verify Finalize Operation

Name	Length	Value	Description
ECC Verify Operation	1	0x03	Finalize verification operation
Signature	64	-	Signature to verify
Input Data Source	1	<a href="#">Table 40</a>	
Input Data Length	[1]	0xXX	Length of input data, only present when the input source is an internal buffer
Input Data	[XX]	-	Raw data bytes, only present when input source is the command buffer

Table 202. [CryptoRequest ECC\\_Verify](#) - ECC Verify One-Shot Operation

Name	Length	Value	Description
ECC Verify Operation	1	0x04	One-shot verification operation
Algorithm	1	0x00	ECDSA with SHA-256
Curve	1	0x0C	NIST 256
		0x0D	Brainpool 256
Host's Public Key	65	-	The public key to use for signature verification provided in uncompressed format
Signature	64	-	Signature to verify
Input Data Source	1	<a href="#">Table 40</a>	
Input Data Length	[1]	0xXX	Length of input data, only present when the input source is an internal buffer
Input Data	[XX]	-	Raw data bytes, only present when input source is the command buffer

Table 203. [CryptoRequest ECC\\_Verify](#) - ECC Verify One-Shot Pre-computed Hash Operation

Name	Length	Value	Description
ECC Verify Operation	1	0x05	One-shot with pre-somputed hash operation
Algorithm	1	0x00	ECDSA with SHA-256
Curve	1	0x0C	NIST 256
		0x0D	Brainpool 256
Host's Public Key	65	-	The public key to use for signature verification provided in uncompressed format i.e. leading 0x04 byte
Signature	64	-	Signature to verify

Table 203. [CryptoRequest ECC\\_Verify](#) - ECC Verify One-Shot Pre-computed Hash Operation...continued

Name	Length	Value	Description
Input Data Source	1	<a href="#">Table 40</a>	
Input Data Length	[1]	0x20	Length of input data, only present when the input source is an internal buffer
Input Data	[0x20]	-	Hash data bytes only present when input source is the command buffer

Table 204. Response description - ECC Verify Operation

Name	Length	Value	Description
Response data	[2]	-	Signature verification result if operation is finalize or one-shot: 0x5A5A if successfully, otherwise 0xA5A5
SW1SW2	2	0x9100 0x91XX	successful execution Refer to <a href="#">Table 183</a> and <a href="#">Table 205</a>

Table 205. Error Code Description - ECC Verify Operation

Status	Value	Description
Resp.PARAMETER_ERROR	0x9E	Public key format byte is not uncompressed 0x04

### 7.10.5 CryptoRequest ECC DH

The ECC Diffie-Hellman API supports the use of static keys or ephemeral keys. In addition, it allows the shared secret to be generated using a single or two-step approach. The output destination of the 32 byte shared secret shall be either the command buffer or an internal buffer.

If using a single step and the key pair Id indicates an ephemeral key then the ephemeral public key shall be output in the command buffer. The shared secret shall be output to the destination specified..

If using a two-step approach and the key pair Id indicates an ephemeral key, then the ephemeral public key shall be output in the command buffer in step 1. In the second step, the shared secret shall be output to the destination specified.

Table 206. [CryptoRequest ECC\\_DH](#) - ECC DH Single-step Operation

Name	Length	Value	Description
ECC DH Operation	1	0x01	One-step operation
Key Pair Id	1	0x00 - 0x04	Static key pair - the key pair must be marked as 'Crypto API ECDH'
		0xFE	Use NIST 256 ephemeral key pair
		0xFF	Use Brainpool 256 ephemeral key pair
Shared secret destination	1	<a href="#">Table 40</a>	
Public key of the Host	65	-	The host's public key to use for shared secret generation, provided in uncompressed format i.e leading 0x04 byte

Table 207. [CryptoRequest ECC\\_DH](#) - ECC DH Two-step Step 1

Name	Length	Value	Description
ECC DH Operation	1	0x02	Two step - first step
Key Pair Id	1	0x00 - 0x04	Static key pair - the key pair must be marked as 'Crypto API ECDH'
		0xFE	Use NIST 256 ephemeral key pair
		0xFF	Use Brainpool 256 ephemeral key pair

Table 208. [CryptoRequest ECC\\_DH](#) - ECC DH Two-step Step 2

Name	Length	Value	Description
ECC DH Operation	1	0x03	Two step - final step
Key Pair Id	1	0x00 - 0x04	Static key pair - the key pair must be marked as 'Crypto API ECDH'
		0xFE	Use NIST 256 ephemeral key pair
		0xFF	Use Brainpool 256 ephemeral key pair
Shared secret destination	1	<a href="#">Table 40</a>	
Host's public key	65	-	The host's public key to use for shared secret generation, provided in uncompressed format i.e leading 0x04 byte

Table 209. Response description - ECC DH Operation

Name	Length	Value	Description
Card's ephemeral publickey	[65]	-	If key pair Id indicates an ephemeral key and single step or two-step step 1
Shared Secret	[32]	-	If single step or two-step step 2 and output destination is the command buffer
SW1SW2	2	0x9100 0x91XX	successful execution Refer to <a href="#">Table 183</a> and <a href="#">Table 210</a>

Table 210. Error Code Description - ECC DH Operation

Status	Value	Description
Resp.PERMISSION_DENIED	0x9D	Key id valid but key is not marked as 'crypto API ECDH'
Resp.LENGTH_ERROR	0x9D	Key usage counter limit is enabled and has been reached
Resp.LENGTH_ERROR	0x9D	Two-step step 2 operation is specified and no ongoing Two-step operation
Resp.LENGTH_ERROR	0x9D	Two-step step 2 operation and key id not consistent with step 1

7.10.6 CryptoRequest AES

The AES API supports the use of static crypto API keys or keys stored in an internal buffer. The AES primitives supported by a static key are defined by the KeyPolicy set via the [ChangeKey](#) command.

Table 211. [Crypto API AES Key Selection](#)

b7	b6	b5	b4	b3	b2	b1	b0	Description
0	0	0	1	0	Key Id			Id of AES Key (must be in crypto API range: '10' – '17'), the key length from the static key
1	0	0	0	0	Slot Num			Transient buffer slot number containing the AES key, the key length shall be in the following field
1	1	0	0	Slot Num				Static buffer slot number containing the AES key, the key length shall be in the following field

The output destination for multi-part AES encryption and decryption shall always be the command buffer. For a one-shot operation, the result destination can be an internal buffer.

Table 212. [Crypto API AES Key Selection](#) - AES Enc/Dec Init Operation

Name	Length	Value	Description
AES Operation	1	0x01	Init operation
AES Primitive	1	0x03	AES-CBC Encrypt
		0x04	AES-CBC Decrypt
		0x05	AES-ECB Encrypt
		0x06	AES-ECB Decrypt
AES Key Id	1	<a href="#">Table 211</a>	Id of the AES key
AES Key length	[1]	0x10 or 0x20	Length of AES key, only present when the key source is an internal buffer.
ICV Source	[1]	<a href="#">Table 40</a>	Only present for CBC operations.
ICV	[16]	-	Only present for CBC operations and the ICV is in the command buffer.
Input Data Source	1	<a href="#">Table 40</a>	
Input Data Length	[1]	0xXX	Length of input data, only present when the input source is an internal buffer
Input Data	[XX]	-	Raw data bytes, only present when input source is the command buffer

Table 213. [Crypto API AES Key Selection](#) - AES Enc/Dec Update Operation

Name	Length	Value	Description
AES Operation	1	0x02	Update data to be processed
Input Data Source	1	<a href="#">Table 40</a>	
Input Data Length	[1]	0xXX	Length of input data, only present when the input source is an internal buffer
Input Data	[XX]	-	Raw data bytes, only present when input source is the command buffer

Table 214. [Crypto API AES Key Selection](#) - AES Enc/Dec Finalize Operation

Name	Length	Value	Description
AES Operation	1	0x03	finalize the operation
Input Data Source	1	<a href="#">Table 40</a>	
Input Data Length	[1]	0xXX	Length of input data, only present when the input source is an internal buffer
Input Data	[XX]	-	Raw data bytes, only present when input source is the command buffer

Table 215. [Crypto API AES Key Selection](#) - Format of crypto API AES Enc/Dec multi-part operation response data

Name	Length	Value	Description
Output Result	[16-224]	-	Output is always present apart from first call if input data is 16 bytes or less as card stores 1 block of data until the finalize call.
SW1SW2	2	0x9100 0x91XX	successful execution Refer to <a href="#">Table 183</a> and <a href="#">Table 218</a>

Table 216. [Crypto API AES Key Selection](#) - AES Enc/Dec One-Shot Operation

Name	Length	Value	Description
AES Operation	1	0x04	One-shot operation
AES Primitive	1	0x03	AES-CBC Encrypt
		0x04	AES-CBC Decrypt
		0x05	AES-ECB Encrypt
		0x06	AES-ECB Decrypt
AES Key Id	1	<a href="#">Table 211</a>	Id of the AES key
AES Key length	[1]	0x10 or 0x20	Length of AES key, only present when the key source is an internal buffer.
ICV Source	[1]	<a href="#">Table 40</a>	Only present for CBC operations.
ICV	[16]	-	Only present for CBC operations and the ICV is in the command buffer.
Input Data Source	1	<a href="#">Table 40</a>	
Input Data Length	[1]	0xXX	Length of input data, only present when the input source is an internal buffer
Input data	[XX]	-	Raw data bytes, only present when input source is the command buffer
Result Destination	1	<a href="#">Table 40</a>	

Table 217. [Crypto API AES Key Selection](#) - Format of crypto API AES Enc/Dec One-shot operation response data

Name	Length	Value	Description
Output Result	[16-224]	-	Only present when result destination is the command buffer
SW1SW2	2	0x9100 0x91XX	successful execution Refer to <a href="#">Table 183</a> and <a href="#">Table 218</a>

Table 218. Error Code Description - AES Operation

Status	Value	Description
Resp.PARAMETER_ERROR	0x9E	Key id valid but key does not support AES operation key
Resp.PARAMETER_ERROR	0x9E	Total input data length is specified and the cumulative Input data bytes received in the Initialize, Update, and Finalize or One-shot operations does not match the Total Input data length field

### 7.10.7 CryptoRequest AES CMAC

The AES API supports the use of static crypto API keys or keys stored in an internal buffer. The AES primitives supported by a static key are defined by the KeyPolicy set via the [ChangeKey](#) command.

The CMAC Signature shall be output to the command buffer (16 bytes of raw signature data).

Table 219. [CryptoRequest AES CMAC](#) - AES CMAC Sign Init Operation

Name	Length	Value	Description
AES Operation	1	0x01	Init operation
AES Primitive	1	0x01	AES-CMAC Sign
AES Key Id	1	<a href="#">Table 211</a>	Id of the AES Key
AES Key length	[1]	0x10 or 0x20	Length of AES key, only present when the key source is an internal buffer.
Input Data Source	1	<a href="#">Table 40</a>	
Input Data Length	[1]	0xXX	Length of input data, only present when the input source is an internal buffer
Input Data	[XX]	-	Raw data bytes, only present when input source is the command buffer

Table 220. [CryptoRequest AES CMAC](#) - AES CMAC Sign Update Operation

Name	Length	Value	Description
AES Operation	1	0x02	Update data to be signed
Input Data Source	1	<a href="#">Table 40</a>	
Input Data Length	[1]	0xXX	Length of input data, only present when the input source is an internal buffer
Input Data	[XX]	-	Raw data bytes, only present when input source is the command buffer

Table 221. [CryptoRequest AES CMAC](#) - AES CMAC Sign Finalize Operation

Name	Length	Value	Description
AES Operation	1	0x03	Finalize the signature generation operation
Input Data Source	1	<a href="#">Table 40</a>	
Input Data Length	[1]	0xXX	Length of input data, only present when the input source is an internal buffer
Input Data	[XX]	-	Raw data bytes, only present when input source is the command buffer

Table 222. [CryptoRequest AES CMAC](#) - AES CMAC Sign One-shot Operation

Name	Length	Value	Description
AES Operation	1	0x04	One-shot operation
AES Primitive	1	0x01	AES-CMAC Sign
AES Key Id	1	<a href="#">Table 211</a>	Id of the AES Key
AES Key length	[1]	0x10 or 0x20	Length of AES key, only present when the key source is an internal buffer.
Input Data Source	1	<a href="#">Table 40</a>	
Input Data Length	[1]	0xXX	Length of input data, only present when the input source is an internal buffer
Input Data	[XX]	-	Raw data bytes, only present when input source is the command buffer

Table 223. [CryptoRequest AES CMAC](#) - Format of crypto API AES CMAC Sign response data

Name	Length	Value	Description
Output Result	[16]	-	16 bytes CMAC signature if one-shot or finalize operation
SW1SW2	2	0x9100 0x91XX	successful execution Refer to <a href="#">Table 183</a> and <a href="#">Table 229</a>

The CMAC signature to verify shall be provided in the command buffer. The input data shall be provided in the command buffer or an internal buffer. The signature verification result shall be provided as response data and shall be 0x5A5A upon successful verification or 0xA5A5 if verification fails.

Table 224. [CryptoRequest AES CMAC](#) - AES CMAC Verify Init Operation

Name	Length	Value	Description
AES Operation	1	0x01	Init operation
AES Primitive	1	0x02	AES-CMAC Verify
AES Key Id	1	<a href="#">Table 211</a>	Id of the AES Key
AES Key length	[1]	0x10 or 0x20	Length of AES key, only present when the key source is an internal buffer.
Input Data Source	1	<a href="#">Table 40</a>	
Input Data Length	[1]	0xXX	Length of input data, only present when the input source is an internal buffer

Table 224. [CryptoRequest AES CMAC](#) - AES CMAC Verify Init Operation...continued

Name	Length	Value	Description
Input Data	[XX]	-	Raw data bytes, only present when input source is the command buffer

Table 225. [CryptoRequest AES CMAC](#) - AES CMAC Verify Update Operation

Name	Length	Value	Description
AES Operation	1	0x02	Update data to be verified
Input Data Source	1	<a href="#">Table 40</a>	
Input Data Length	[1]	0xXX	Length of input data, only present when the input source is an internal buffer
Input Data	[XX]	-	Raw data bytes, only present when input source is the command buffer

Table 226. [CryptoRequest AES CMAC](#) - AES CMAC Verify Finalize Operation

Name	Length	Value	Description
AES Operation	1	0x03	Finalize the signature verification operation
CMAC Length	1	0x08 or 0x10	CMAC signature length
CMAC Signature	8 or 16	-	
Input Data Source	1	<a href="#">Table 40</a>	
Input Data Length	[1]	0xXX	Length of input data, only present when the input source is an internal buffer
Input Data	[XX]	-	Raw data bytes, only present when input source is the command buffer

Table 227. [CryptoRequest AES CMAC](#) - AES CMAC Verify One-shot Operation

Name	Length	Value	Description
AES Operation	1	0x04	One-shot operation
AES Primitive	1	0x02	AES-CMAC Verify
AES Key Id	1	<a href="#">Table 211</a>	Id of the AES Key
AES Key length	[1]	0x10 or 0x20	Length of AES key, only present when the key source is an internal buffer.
CMAC Length	1	0x08 or 0x10	CMAC signature length
CMAC Signature	8 or 16	-	
Input Data Source	1	<a href="#">Table 40</a>	
Input Data Length	[1]	0xXX	Length of input data, only present when the input source is an internal buffer
Input Data	[XX]	-	Raw data bytes, only present when input source is the command buffer

Table 228. [CryptoRequest AES CMAC](#) - Format of crypto API AES CMAC Verify response data

Name	Length	Value	Description
Output Result	[2]	-	Signature verification result if one-shot or finalize operation: 0x5A5A if successful, otherwise 0xA5A5
SW1SW2	2	0x9100 0x91XX	successful execution Refer to <a href="#">Table 183</a> and <a href="#">Table 229</a>

Table 229. Error Code Description - AES Operation

Status	Value	Description
Resp.PARAMETER_ERROR	0x9E	Key id valid but key does not support AES operation key
Resp.PARAMETER_ERROR	0x9E	Verify operation and MAC doesn't equal hash size
Resp.PARAMETER_ERROR	0x9E	Primitive indicates AES-CMAC verify and the CMAC length is not 8 bytes or 16 bytes
Resp.PARAMETER_ERROR	0x9E	Total input data length is specified and the cumulative Input data bytes received in the Initialize, Update, and Finalize or One-shot operations does not match the Total Input data length field.

### 7.10.8 CryptoRequest AES AEAD

The AES API supports the use of static crypto API keys or keys stored in an internal buffer. The AES primitives supported by a static key are defined by the KeyPolicy set via the [ChangeKey](#) command.

The output destination for multi-part AEAD shall always be the command buffer. For a one-shot operation, the result destination can be an internal static or transient buffer.

Table 230. [CryptoRequest AES AEAD](#) - AES AEAD Initialize Operation

Name	Length	Value	Description
AES Operation	1	0x01	Initialize operation
AES Primitive	1	0x07	AES-CCM Encrypt/Sign
		0x08	AES-CCM Encrypt/Sign with internally generated nonce
		0x09	AES-CCM Decrypt/Verify
		0x0A	AES-GCM Encrypt/Sign
		0x0B	AES-GCM Encrypt/Sign with internally generated nonce
		0x0C	AES-GCM Decrypt/Verify
AES Key Id	1	<a href="#">Table 211</a>	Id of the AES key
AES Key length	[1]	0x10 or 0x20	Length of AES key, only present when the key source is an internal buffer.
Nonce Source	[1]	<a href="#">Table 40</a>	Not present when internally generated – AES primitive 0x08 or 0x0B
Nonce length	1	0x0D	AES CCM
		0x0C - 0x3C	AES GCM
Nonce	[XX]	-	Not present when Nonce is internally generated – AES primitive 0x08 or 0x0B
AAD Source	1	<a href="#">Table 40</a>	
AAD Length	1	0xXX	Number of AAD bytes.

Table 230. [CryptoRequest AES AEAD](#) - AES AEAD Initialize Operation...continued

Name	Length	Value	Description
AAD	[XX]	-	
Input Data Source	1	<a href="#">Table 40</a>	
Input Data Length	1	0xXX	Length of input data
Input data	[XX]	-	Raw data bytes. Note all AAD data must be received before any input data can be processed.
Result Destination	[1]	<a href="#">Table 40</a>	Only present when Action is 0x0C Decrypt/Verify.

Table 231. [CryptoRequest AES AEAD](#) - Format of crypto API AES AEAD Initialize operation response data

Name	Length	Value	Description
Nonce	[1]	-	Only present when Nonce is internally generated i.e. Primitive is Encrypt/Sign with internally generated Nonce 0x08 or 0x0B
Output Data	[XX]	-	Encrypted/decrypted data. The length shall be less than or equal to Input data lengths since up to 16 bytes of input data can be buffered for the next update or finalize command
SW1SW2	2	0x9100 0x91XX	successful execution Refer to <a href="#">Table 183</a> and <a href="#">Table 238</a>

Table 232. [CryptoRequest AES AEAD](#) - AES AEAD Update Operation

Name	Length	Value	Description
AES Operation	1	0x02	Update AAD or Input data operation
AAD Source	1	<a href="#">Table 40</a>	
AAD Length	1	0xXX	Number of AAD bytes.
AAD	[XX]	-	
Input Data Source	1	<a href="#">Table 40</a>	
Input Data Length	1	0xXX	Length of input data. Note all AAD data must be received before any input data can be processed.
Input data	[XX]	-	Raw data bytes
Result Destination	1	<a href="#">Table 40</a>	Only present when Action is 0x0C Decrypt/Verify.

Table 233. [CryptoRequest AES AEAD](#) - Format of crypto API AES AEAD Update operation response data

Name	Length	Value	Description
Output Data	[XX]	-	Encrypted/decrypted data. The length shall be less than or equal to Input data lengths since up to 16 bytes of input data can be buffered for the next update or finalize command
SW1SW2	2	0x9100 0x91XX	successful execution Refer to <a href="#">Table 183</a> and <a href="#">Table 238</a>

Table 234. [CryptoRequest AES AEAD](#) - AES AEAD Finalize Operation

Name	Length	Value	Description
AES Operation	1	0x03	Finalize existing operation
AAD Source	1	<a href="#">Table 40</a>	
AAD Length	1	0xXX	Number of AAD bytes.
AAD	[XX]	-	
Input Data Source	1	<a href="#">Table 40</a>	
Input Data Length	1	0xXX	The last block of input data
Input data	[XX]	-	Note all AAD data must be received before any input data can be processed.
Tag Length	[1]	0x08 or 0x10	CCM
		0x0C or 0x10	GCM
Tag Data	[XX]	-	Only present when Action is 0x0C Decrypt/Verify.
Result Destination	1	<a href="#">Table 40</a>	Only present when Action is 0x0C Decrypt/Verify.

Table 235. [CryptoRequest AES AEAD](#) - Format of crypto API AES AEAD finalize operation response data

Name	Length	Value	Description
Output Data	[XX]	-	Encrypted/decrypted data. The length shall be at minimum the input length but can be up to 16 bytes greater due to possible buffering of input data from the previous initialize or update command
Tag Data	[XX]	-	Tag data when performing an enc/sign operation i.e. Action 0x0B and AES primitive 0x08 or 0x0B
Verification Result	[2]	-	0x5A5A for successful verification, 0xA5A5 for failed verification. Only present when Action is 0x0C Decrypt/Verify.
SW1SW2	2	0x9100 0x91XX	successful execution Refer to <a href="#">Table 183</a> and <a href="#">Table 238</a>

Table 236. [CryptoRequest AES AEAD](#) - AES AEAD One-Shot Operation

Name	Length	Value	Description
AES Operation	1	0x04	One-shot operation
AES Primitive	1	0x07	AES-CCM Encrypt/Sign
		0x08	AES-CCM Encrypt/Sign with internally generated nonce
		0x09	AES-CCM Decrypt/Verify
		0x0A	AES-GCM Encrypt/Sign
		0x0B	AES-GCM Encrypt/Sign with internally generated nonce
		0x0C	AES-GCM Decrypt/Verify
AES Key Id	1	<a href="#">Table 211</a>	Id of the AES key
AES Key length	[1]	0x10 or 0x20	Length of AES key, only present when the key source is an internal buffer.

Table 236. [CryptoRequest AES AEAD](#) - AES AEAD One-Shot Operation...continued

Name	Length	Value	Description
Nonce Source	[1]	<a href="#">Table 40</a>	Not present when internally generated – AES primitive 0x08 or 0x0B
Nonce length	1	0x0D	AES CCM
		0x0C - 0x3C	AES GCM
Nonce	[XX]	-	Not present when Nonce is internally generated – AES primitive 0x08 or 0x0B
AAD Source	1	<a href="#">Table 40</a>	
AAD Length	1	0xXX	Number of AAD bytes.
AAD	[XX]	-	
Input Data Source	1	<a href="#">Table 40</a>	
Input Data Length	1	0xXX	Length of input data
Input data	[XX]	-	Raw data bytes
Tag Length	1	0x08 or 0x10	CCM
		0x0C or 0x10	GCM
Tag Data	[XX]	-	Only present when Action is 0x0C Decrypt/Verify.
Result Destination	1	<a href="#">Table 40</a>	Only present when Action is 0x0C Decrypt/Verify.

Table 237. [CryptoRequest AES AEAD](#) - Format of crypto API AES AEAD One-shot operation response data

Name	Length	Value	Description
Nonce	[1]	-	Only present when Nonce is internally generated i.e. Primitive is Encrypt/Sign with internally generated Nonce 0x08 or 0x0B
Output Data	[XX]	-	Encrypted/decrypted data. The length shall be at minimum the input length but can be up to 16 bytes greater due to possible buffering of input data from the previous initialize or update command
Tag Data	[XX]	-	Tag data when performing an enc/sign operation i.e. Action 0x0B and AES primitive 0x08 or 0x0B
Verification Result	[2]	-	0x5A5A for successful verification, 0xA5A5 for failed verification. Only present when Action is 0x0C Decrypt/Verify.
SW1SW2	2	0x9100 0x91XX	successful execution Refer to <a href="#">Table 183</a> and <a href="#">Table 238</a>

Table 238. Error Code Description - AES Operation

Status	Value	Description
Resp.PARAMETER_ERROR	0x9E	Key id valid but key does not support AES operation key
Resp.PARAMETER_ERROR	0x9E	Primitive indicates CCM and the ICV isn't specified as 13 bytes
Resp.PARAMETER_ERROR	0x9E	Primitive indicates GCM and the ICV length is not in the range 12 to 60 bytes

Table 238. Error Code Description - AES Operation...continued

Status	Value	Description
Resp.PARAMETER_ERROR	0x9E	Total AAD length is specified and the cumulative AAD bytes received in the Initialize, Update, and Finalize or One-shot operations does not match the Total AAD length field
Resp.PARAMETER_ERROR	0x9E	Total input data length is specified and the cumulative Input data bytes received in the Initialize, Update and Finalize or One-shot operations does not match the Total Input data length field.
Resp.PARAMETER_ERROR	0x9E	Operation is AEAD CCM and the Tag field length isn't 0x08 or 0x10

### 7.10.9 CryptoRequest Write Internal Buffer

It is possible to write a specific value to an internal buffer using this command option. This allows data to be loaded for use within other crypto API operations.

Table 239. [CryptoRequest - Write Internal Buffer Operation](#)

Name	Length	Value	Description
Destination	1	<a href="#">Table 40</a>	
Length	1		The number of bytes to write (1 byte granularity supported)
Data	XX		Data to write to the internal buffer

Table 240. Response description - Write Internal Buffer

Name	Length	Value	Description
SW1SW2	2	0x9100 0x91XX	successful execution Refer to <a href="#">Table 183</a>

### 7.10.10 CryptoRequest HMAC

It is possible to execute an HMAC calculation using a single command or as a series of commands. Using multiple steps allows the input data to be taken from different sources. The API uses a secure SHA implementation. A successful HMAC signature verification shall give response data 0x5A5A and a failed HMAC signature verification result shall give response data 0xA5A5.

Table 241. [CryptoRequest HMAC - HMAC Operation](#)

Name	Length	Value	Description
HMAC Operation	1	0x01	Initialize HMAC operation
		0x02	Update existing HMAC operation
		0x03	Finalize existing HMAC operation
		0x04	One-shot HMAC operation
HMAC Primitive	1	0x01	HMAC Sign
		0x02	HMAC Verify
Digest Algorithm	[1]	-	Required for Initialize and One-shot operations
		0x01	SHA256
		0x02	SHA384

Table 241. [CryptoRequest HMAC](#) - HMAC Operation...continued

Name	Length	Value	Description
Key Id	[1]	<a href="#">Table 211</a>	Id of the HMAC key, required for Initialize and One-shot operations, otherwise absent
Key length	[1]	0x01 to 0xFF	Length of HMAC key, only present when the key source is an internal buffer.
HASH Mac	[1]	0x20 or 0x30	HASH MAC bytes. Length is equal to the Digest algorithm output length. Required for Finalize and One-shot operations when performing HMAC Verify, otherwise absent
Input Data Source	1	<a href="#">Table 40</a>	
Input Data Length	[1]	0xXX	Length of data to use (only needed if input source is an internal buffer, otherwise implied from Lc)
Input data	[XX]	-	Input data if input source is the command buffer
Result Destination	1	<a href="#">Table 40</a>	Required for Finalize and One-shot sign operations, otherwise absent

Table 242. Response description - HMAC Verify Operation

Name	Length	Value	Description
Response data	2	-	Verification result: 0x5A5A if successful, otherwise 0xA5A5
SW1SW2	2	0x9100 0x91XX	successful execution Refer to <a href="#">Table 183</a> and <a href="#">Table 244</a>

Table 243. Response description - HMAC Sign Operation

Name	Length	Value	Description
Response data	[32 or 48]	-	Hmac signature if output destination is the command buffer
SW1SW2	2	0x9100 0x91XX	successful execution Refer to <a href="#">Table 183</a> and <a href="#">Table 244</a>

Table 244. Error Code Description - HMAC Operation

Status	Value	Description
Resp.PARAMETER_ERROR	0x9E	Key id valid but key not an HMAC key
Resp.PARAMETER_ERROR	0x9E	Verify operation and MAC doesn't equal hash size

## 7.10.11 CryptoRequest HKDF

HKDF, as defined in RFC5869, requires execution of the extract operation followed by the expand operation. The API uses a secure SHA implementation.

Table 245. [CryptoRequest HKDF](#) - HKDF Extract and Expand Operation

Name	Length	Value	Description
HKDF Operation	1	0x00	Extract and expand
Digest Algorithm	1	0x01	SHA256
		0x02	SHA384
Key Id	1	<a href="#">Table 211</a>	Initial Key Material (IKM)
Key length	[1]	0x01 to 0xFF	Length of HMAC key, only present when the key source is an internal buffer.
Salt Source	1	<a href="#">Table 40</a>	
Salt Length	1	0x00 to 0x80	Length of salt – If salt length is 0 then a zero salt value of hash length bytes shall be used
Salt Data	[XX]	-	Salt data if salt source is the command buffer
Info Source	1	<a href="#">Table 40</a>	
Info Length	1	0x01 to 0x50	Length of context and info data. Note that zero length is not supported.
Info Data	[XX]	-	Context data if context source is the command buffer
Result Destination	1	<a href="#">Table 40</a>	
Result Length	1	0x01 to 0xEF	Number of bytes to output

Table 246. [CryptoRequest HKDF](#) - HKDF Expand Operation

Name	Length	Value	Description
HKDF Operation	1	0x01	Expand
Digest Algorithm	1	0x01	SHA256
		0x02	SHA384
Key Id	1	<a href="#">Table 211</a>	Pseudorandom key (PRK)
Key length	[1]	0x20 or 0x30	Length of PRK, only present when the key source is an internal buffer. Length must be equal to the Hash byte length.
Info Source	1	<a href="#">Table 40</a>	
Info Length	1	0x01 to 0x50	Length of context and info data. <b>Note:</b> Zero length is not supported.
Info Data	[XX]	-	Context data if context source is the command buffer
Result Destination	1	<a href="#">Table 40</a>	
Result Length	1	0x01 to 0xEF	Number of bytes to output

Table 247. Response description - HKDF Operation

Name	Length	Value	Description
Response data	[1 - 239]	-	HKDF result if output destination is the command buffer
SW1SW2	2	0x9100 0x91XX	successful execution Refer to <a href="#">Table 183</a> and <a href="#">Table 248</a>

Table 248. Error Code Description - HKDF Operation

Status	Value	Description
Resp.PARAMETER_ERROR	0x9E	Key id valid but key not an HKDF key
Resp.LENGTH_ERROR	0x7E	Length of command data not consistent with the length fields specified

Application Remark:

HKDF expand operation fails with error message 910E if Info Length is zero.

### 7.10.12 CryptoRequest Echo

It is possible to have the device echo the command data provided to it. This may be useful to verify system setup.

Table 249. [CryptoRequest Echo](#) - Echo Operation

Name	Length	Value	Description
Additional Data Bytes	0x00 - 0xFE	-	Additional bytes to echo

Table 250. Response description - Echo Operation

Name	Length	Value	Description
Echo Operation Byte	1	0xFD	
Additional bytes	[1 - 254]	-	Addition bytes received in the command data
SW1SW2	2	0x9100 0x91XX	successful execution Refer to <a href="#">Table 183</a>

7.11 GPIO Management

7.11.1 ManageGPIO

The detailed description of this command can be found in [Section 6.14.2](#).

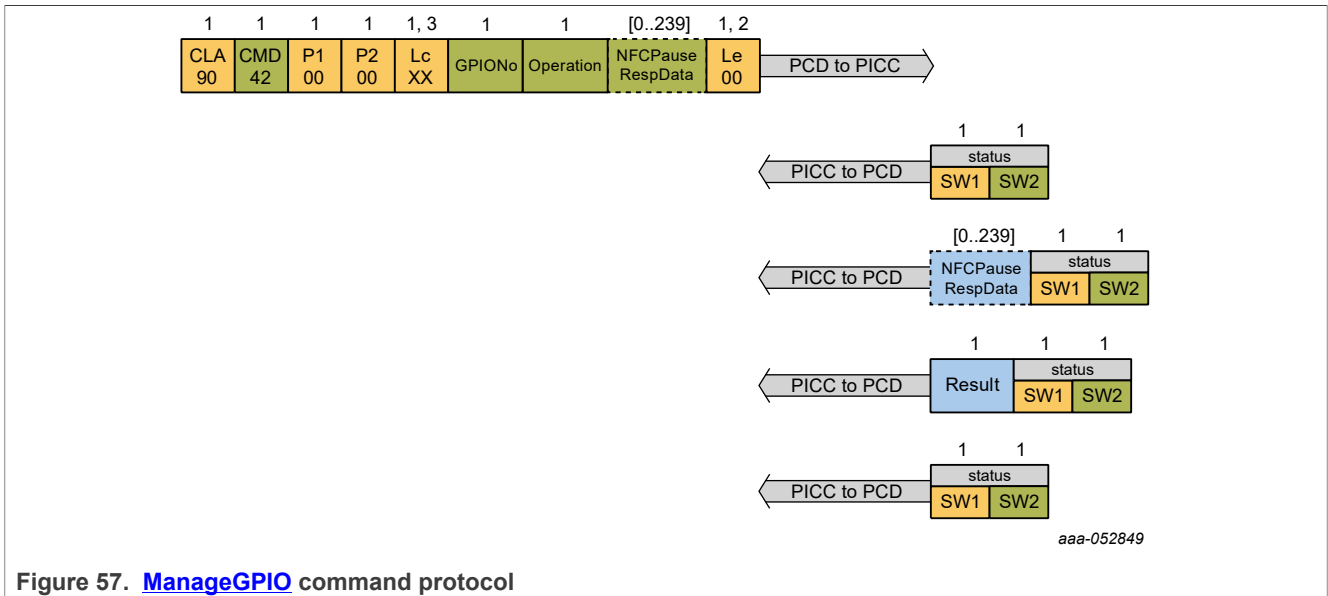

Table 251. [ManageGPIO](#)

<a href="#">ManageGPIO</a>	
Description:	Manages the GPIO output.
CommMode:	CommMode of <a href="#">ManageGPIO</a> as defined by <a href="#">SetConfiguration</a> 0x11.

Table 252. Command Description - [ManageGPIO](#)

Name	Length	Value	Description
<b>Command Header Parameters</b>			
CMD	1	0x42	Command code.
GPIONo	1	-	GPIO Number
		0x00	GPIO1
		0x01	GPIO2
Operation	1	-	Targeted operation
	Bit 7	-	[if GPIOxMode is output] NFC Control
		'0'	No NFC action
		'1'	[if over NFC] Pause NFC
		'1'	[if over I2C] Release NFC Pause
	Bit 6-2	'00000'	[if GPIOxMode is output] RFU

Table 252. Command Description - [ManageGPIO](#) ...continued

Name	Length	Value	Description	
	Bit 1-0	-	[if GPIOxMode is output] GPIO Control	
		'00'	CLEAR: clear the GPIO state to LOW (not driven).	
		'01'	SET: set the GPIO State to HIGH (driven).	
		'10'	TOGGLE: toggle the GPIO State.	
		'11'	RFU	
		Bit 7-2	-	[if GPIOxMode is down-stream power out] Target voltage/current level
			0x00	Default level as configured with <a href="#">SetConfiguration</a>
			0x01	Power downstream voltage of 1.8 V and current of 100 µA
			0x02	Power downstream voltage of 1.8 V and current of 300 µA
			0x03	Power downstream voltage of 1.8 V and current of 500 µA
			0x04	Power downstream voltage of 1.8 V and current of 1 mA
			0x05	Power downstream voltage of 1.8 V and current of 2 mA
			0x06	Power downstream voltage of 1.8 V and current of 3 mA
			0x07	Power downstream voltage of 1.8 V and current of 5 mA
			0x08	Power downstream voltage of 1.8 V and current of 7 mA
			0x09	Power downstream voltage of 1.8 V and current of 10 mA
			0x0F	Power downstream voltage of 1.8 V and maximal available current
			0x11	Power downstream voltage of 2 V and current of 100 µA
			0x12	Power downstream voltage of 2 V and current of 300 µA
			0x13	Power downstream voltage of 2 V and current of 500 µA
			0x14	Power downstream voltage of 2 V and current of 1 mA
			0x15	Power downstream voltage of 2 V and current of 2 mA
			0x16	Power downstream voltage of 2 V and current of 3 mA
			0x17	Power downstream voltage of 2 V and current of 5 mA
	0x18	Power downstream voltage of 2 V and current of 7 mA		
	0x19	Power downstream voltage of 2 V and current of 10 mA		
	0x1F	Power downstream voltage of 2 V and maximal available current		
	Bit 1	-	[if GPIOxMode is down-stream power out] GPIO Measurement Control	
		'0'	No measurement	
		'1'	MEASURE: execute measurement	
	Bit 0	-	[if GPIOxMode is down-stream power out] GPIO Control	
		'0'	CLEAR: stop power harvesting.	
		'1'	SET: enable power harvesting.	

Table 252. Command Description - [ManageGPIO](#) ...continued

Name	Length	Value	Description
NFCPauseResp Data	[0 .. 239]	Full range	[Optional, present if GPIOXMode is output AND Operation[b7] == '1' AND issued over I2C] NFC Pause Response Data: data to be returned to NFC host in the case of 'Release NFC Pause'

Table 253. Response description - [ManageGPIO](#) [if GPIOXMode is output AND Operation[b7] == '1' AND issued over NFC]

Name	Length	Value	Description
NFCPauseResp Data	[0 .. 239]	Full Range	NFC Pause Response Data: data received from the I2C interface
SW1SW2	2	0x9100 0x91XX	successful execution Refer to <a href="#">Table 256</a>

Table 254. Response description - [ManageGPIO](#) [if GPIOXMode is output AND Operation[b1] == '1' AND issued over NFC]

Name	Length	Value	Description
Result	1	Full Range	Measurement result with unit of 0.1 mA
SW1SW2	2	0x9100 0x91XX	successful execution Refer to <a href="#">Table 256</a>

Table 255. Response description - [ManageGPIO](#) [else]

Name	Length	Value	Description
No response data parameters defined for this command			
SW1SW2	2	0x9100 0x91XX	successful execution Refer to <a href="#">Table 256</a>

Table 256. Error code description - [ManageGPIO](#)

Status	Value	Description
Resp.COMMAND_ABORTED	0xCA	Chained command or multiple pass command ongoing.
Resp.INTEGRITY_ERROR	0x1E	Integrity error in cryptogram or invalid secure messaging MAC
Resp.LENGTH_ERROR	0x7E	Command size not allowed.
Resp.PARAMETER_ERROR	0x9E	Parameter value not allowed.
Resp.PERMISSION_DENIED	0x9D	Not supported at PICC level.
Resp.PERMISSION_DENIED	0x9D	ManageGPIOAccessCondition is configured for no access (0x0F) and not targeting NFC Pause Release.
Resp.PERMISSION_DENIED	0x9D	Pause NFC operation and I2C are not supported.
Resp.PERMISSION_DENIED	0x9D	Release NFC Pause operation and the NFC interface are not paused.

Table 256. Error code description - [ManageGPIO...continued](#)

Status	Value	Description
Resp.PERMISSION_DENIED	0x9D	Targeting GPIO1 while it is not configured for output or downstream power out.
Resp.PERMISSION_DENIED	0x9D	Enabling down-stream power out while not powered over NFC.
Resp.PERMISSION_DENIED	0x9D	Targeting GPIO2 while it is not configured for output or output with NFCPause file.
Resp.PERMISSION_DENIED	0x9D	Triggering execution of MEASURE while down-stream power out was already enabled.
Resp.AUTHENTICATION_ERROR	0xAE	No active authentication granting the ManageGPIOAccess- Condition while different from 0x0F and not targeting NFC Pause Release.
Resp.CERT_ERROR	0xCE	Active ECC-based authentication while ManageGPIOAccess- Condition not granted while different from 0xF and not targeting NFC Pause Release.
Resp.WEAK_FIELD	0x1F	Enabling down-stream power out while NFC field strength does not allow the targeted voltage/current selection.
Resp.PAD_VOLTAGE_UNRELIABLE	0x2F	When enabling power harvesting, pad voltage is too low. Pads are not sufficiently supplied.

7.11.2 [ReadGPIO](#)

The detailed description of this command can be found in [Section 6.14.3](#).

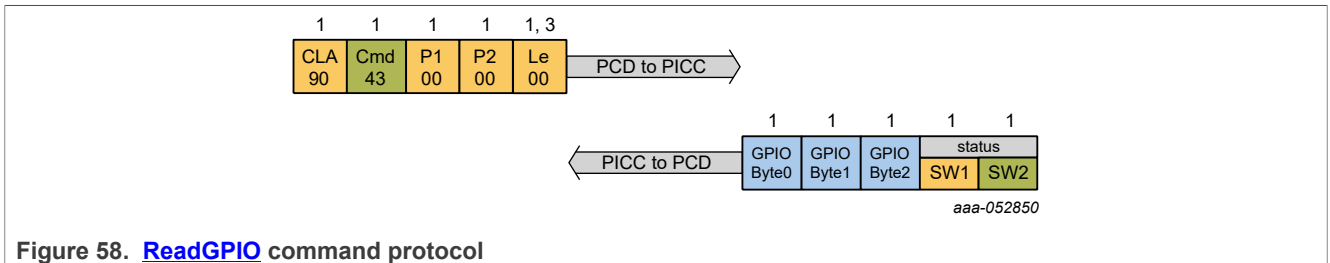

Figure 58. [ReadGPIO](#) command protocol

Table 257. [ReadGPIO](#)

<a href="#">ReadGPIO</a>	
Description:	Returns the GPIO statuses.
CommMode:	CommMode of <a href="#">ReadGPIO</a> as defined by <a href="#">SetConfiguration</a> 0x11.

Table 258. Command Description - [ReadGPIO](#)

Name	Length	Value	Description
<b>Command Header Parameters</b>			
Cmd	1	0x43	Command code.

Table 259. Response description - [ReadGPIO](#)

Name	Length	Value	Description
GPIOByte0	1	-	GPIOStatus bytes as defined in <a href="#">Table 43</a> .

Table 259. Response description - [ReadGPIO...continued](#)

Name	Length	Value	Description
		0x43	[if TagTamper] Close
		0x4F	[if TagTamper] Open
		0x49	[else] Invalid
GPIOByte1	1	-	GPIOStatus bytes as defined in <a href="#">Table 43</a> .
		0x43	[if TagTamper] Close
		0x4F	[if TagTamper] Open
		0x48	[if Input or Output] High
		0x4C	[if Input or Output] Low
		0x49	[else] Invalid
GPIOByte2	1	-	GPIOStatus bytes as defined in <a href="#">Table 43</a> .
		0x48	[if Input or Output] High
		0x4C	[if Input or Output] Low
		0x49	[else] Invalid
SW1SW2	2	0x9100	successful execution
		0x91XX	Refer to <a href="#">Table 260</a>

Table 260. Error code description - [ReadGPIO](#)

Status	Value	Description
COMMAND_ABORTED	0xCA	Chained command or multiple pass command ongoing.
INTEGRITY_ERROR	0x1E	Integrity error in cryptogram or invalid secure messaging MAC
LENGTH_ERROR	0x7E	Command size not allowed.
PARAMETER_ERROR	0x9E	Parameter value not allowed.
PERMISSION_DENIED	0x9D	Not supported at PICC level.
PERMISSION_DENIED	0x9D	ReadGPIOAccessCondition is configured for no access (0x0F).
AUTHENTICATION_ERROR	0xAE	No active authentication granting the ReadGPIOAccessCondition while different from 0x0F
CERT_ERROR	0xCE	Active ECC-based authentication while ReadGPIOAccessCondition not granted while different from 0xF.

7.12 ISO7816-4 Support

7.12.1 ISOSelectFile

The detailed description of this command can be found in [Section 6.17.1.4](#).

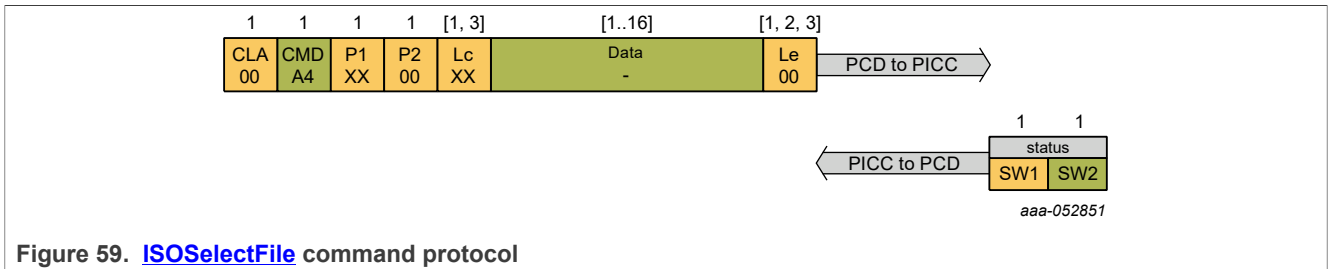

Figure 59. ISOSelectFile command protocol

Table 261. Command summary - ISOSelectFile

ISOSelectFile	
Description:	Select an application or file
CommMode:	N/A

Table 262. Command description - ISOSelectFile

Name	Length	Value	Description
CLA	1	0x00	
INS	1	0xA4	
P1	1	-	Selection Control
		0x00	Select MF, DF or EF, by file identifier
		0x01	Select child DF
		0x02	Select EF under the current DF, by file identifier
		0x03	Select parent DF of the current DF
		0x04	Select by DF name, see <a href="#">[4]</a>
P2	1	-	Option
		0x00	Return FCI template: data stored in the file with ID 0x1F should be returned
		0x0C	No response data: no FCI should be returned
Lc	[1, 3]	0x00 .. 0x10	Length of subsequent data field
Data	[1..16]	-	Reference
		Empty	[if P1 == 0x00 OR P1 == 0x03] Select MF
		Full range	[if P1 == 0x00 OR P1 == 0x01 OR P1 == 0x02] Select with the given file identifier
		Full range	[if P1 == 0x04] Select DF with the given DF name
Le	[1, 2, 3]	Full range	Empty or length of expected response

Table 263. Response description - [ISOSelectFile](#)

Name	Length	Value	Description
Data	[X]	Full range	[Optional] FCI stored in file ID 31 of the DF
SW1SW2	2	0x9000 0XXXXX	successful execution Refer to <a href="#">Table 264</a>

Table 264. Error code description - [ISOSelectFile](#)

SW1 SW2	Value	Description
ISO6700	0x6700	Wrong or inconsistent APDU length.
ISO6985	0x6985	Wrapped chained command or multiple pass command ongoing.
ISO6A82	0x6A82	Application or file not found, currently selected application remains selected.
ISO6A86	0x6A86	Wrong parameter P1 and/or P2
ISO6A87	0x6A87	Wrong parameter Lc inconsistent with P1-P2
ISO6E00	0x6E00	Wrong CLA

7.12.2 **ISOReadBinary**

The detailed description of this command can be found in [Section 6.17.1.5](#).

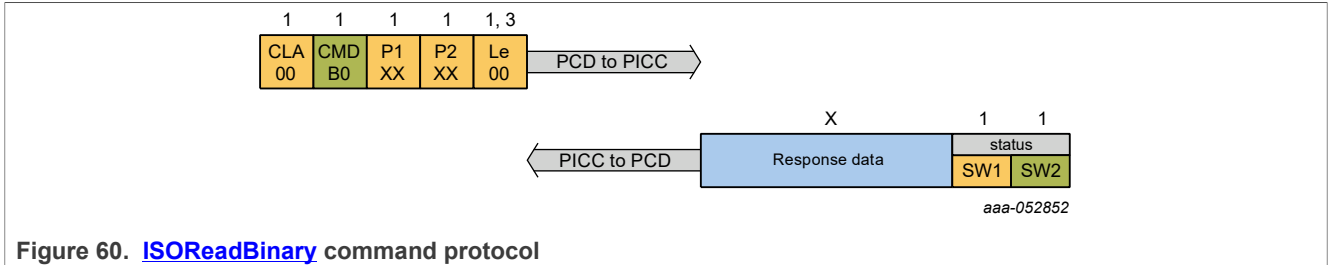

Figure 60. **ISOReadBinary** command protocol

Table 265. Command summary - **ISOReadBinary**

<b>ISOReadBinary</b>	
Description:	Read from a data file
CommMode:	N/A

Table 266. Command description - **ISOReadBinary**

Name	Length	Value	Description
CLA	1	0x00	
INS	1	0xB0	
P1	1		ShortFile ID/Offset
	Bit 7		Encoding
		1b	P1[Bit 6..5] are RFU. P1[Bit 4..0] encode a short ISO FileID. P2[Bit 7..0] encode an offset from zero to 255.
		0b	P1 - P2 (15 bits) encode an offset from zero to 32767.
	Bit 6-5	00b	[if P1[7] == 1b] RFU
	Bit 4-0		[if P1[7] == 1b] short ISO FileID
		0x00	Targeting currently selected file.
0x01 .. 0x1E		Targeting and selecting file referenced by the given short ISO FileID.	
	0x1F	RFU	
Bit 6-0	(see P2)	[if P1[7] == 0b] Most significant bits of Offset	
P2	1	0x000000 .. (File Size - 1)	Offset (see above)
Le	1, 3	-	The number of bytes to be read from the file.
		0x000000	Read the entire data file, starting from the position specified in the offset value.
		0x000001 .. 0xFFFFFFFF	If bigger than (FileSize - Offset), the entire StandardData file starting from the offset position is returned.
		Full range	

Table 267. Response description - [ISOReadBinary](#)

Name	Length	Value	Description
Data	X	-	Data read.
SW1SW2	2	0x9000 0XXXXX	successful execution Refer to <a href="#">Table 268</a>

Table 268. Error code description - [ISOReadBinary](#)

SW1 SW2	Value	Description
ISO6700	0x6700	Wrong or inconsistent APDU length.
ISO6982	0x6982	Security status not satisfied: no access allowed as Read and ReadWrite access rights are different from 0xE and SDMFileRead (if SDM enabled) access right is set to 0xF.
		Security status not satisfied: SDMReadCtr overflow.
		Security status not satisfied: Targeted file cannot be read in <a href="#">VCState.Not Authenticated</a> as the related SDMReadCtr is equal or bigger than its SDMRead CtrLimit.
		Security status not satisfied: AuthenticatedAES not allowed.
		Security status not satisfied: AuthenticatedECC not allowed.
ISO6985	0x6985	Wrapped chained command or multiple pass command ongoing. No file selected. Attempt to read outside file boundaries. Targeted file with ISO FileID 0xEF01 at PICC level, while Originality Check is disabled. Trying to readSDMSIG while the KeyUsageCtrLimit of the targeted key entry is enabled and reached.
ISO6A82	0x6A82	File not found
ISO6A86	0x6A86	Wrong parameter P1 and/or P2
ISO6E00	0x6E00	Wrong CLA

7.12.3 [ISOUpdateBinary](#)

The detailed description of this command can be found in [Section 6.17.1.6](#).

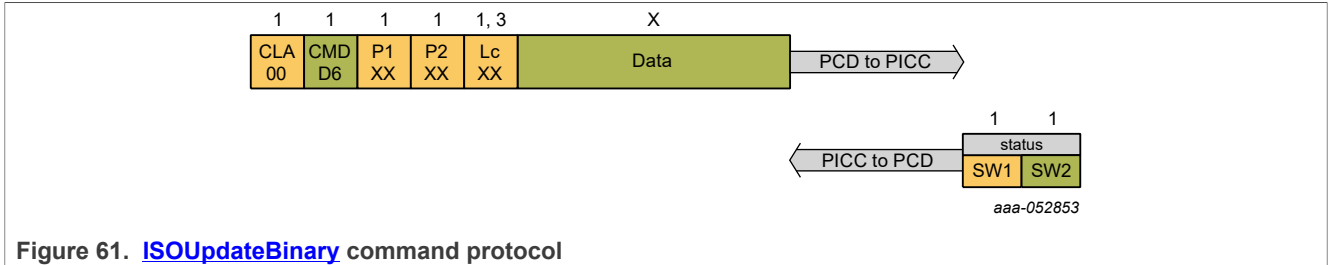

Figure 61. [ISOUpdateBinary](#) command protocol

Table 269. Command summary - [ISOUpdateBinary](#)

<a href="#">ISOUpdateBinary</a>	
Description:	Write to a data file
CommMode:	N/A

Table 270. Command description - [ISOUpdateBinary](#)

Name	Length	Value	Description
CLA	1	0x00	
INS	1	0xD6	
P1	1		ShortFile ID/Offset
	Bit 7		RFU
		1b	P1[Bit 6..5] are RFU. P1[Bit 4..0] encode a short ISO FileID. P2[Bit 7..0] encode an offset from zero to 255.
		0b	P1 - P2 (15 bits) encode an offset from zero to 32767.
	Bit 6-5	00b	[if P1[7] == 1b] RFU
	Bit 4-0		[if P1[7] == 1b] short ISO FileID
		0x00	Targeting currently selected file.
		0x01 .. 0x1E	Targeting and selecting file referenced by the given short ISO FileID.
	0x1F	RFU	
Bit 6-0	(see P2)	[if P1[7] == 0b] Most significant bits of Offset	
P2	1	0x000000 .. (File Size - 1)	Offset (see above)
Lc	1, 3	0x000001 .. (File Size - Offset)	Length of subsequent data field
Data	X	Full range	Data to be written

Table 271. Response description - [ISOUpdateBinary](#)

Name	Length	Value	Description
No response data parameters defined for this command			
SW1SW2	2	0x9000 0XXXXX	successful execution Refer to <a href="#">Table 272</a>

Table 272. Error code description - [ISOUpdateBinary](#)

SW1 SW2	Value	Description
ISO6700	0x6700	Wrong or inconsistent APDU length.
ISO6982	0x6982	Security status not satisfied: only free write with Write or ReadWrite equal to 0xE is allowed. Security status not satisfied: AuthenticatedAES not allowed. Security status not satisfied: AuthenticatedECC not allowed.
ISO6985	0x6985	Wrapped chained command or multiple pass command ongoing. No file selected. Attempt to write beyond the file boundary as set during creation.
ISO6A82	0x6A82	File not found
ISO6A86	0x6A86	Wrong parameter P1 and/or P2
ISO6E00	0x6E00	Wrong CLA

## 8 Limiting values

**Table 273. Limiting values**

In accordance with the Absolute Maximum Rating System (IEC 60134). Voltages are referenced to VSS (ground = 0 V).

Symbol	Parameter	Conditions	Min	Typ	Max	Unit
$V_{CC}$	supply voltage		-0.3	-	+2	V
$V_I$	input voltage	Any supply pad	-0.3	-	+2	V
$I_I$	input current	pads SDA, SCL	-	-	10	mA
$I_O$	output current	pads SDA, SCL	-	-	10	mA
$I_{LU}$	latch-up current	$V_I < 0\text{ V}$ or $V_I > V_{CC}$	-	-	100	mA
$V_{ESD}$	electrostatic discharge voltage	human body model (HBM) <sup>[1]</sup> pads $V_{CC}$ , $V_{SS}$ , SDA, SCL, GPIO1, GPIO2	-	-	+/- 2	kV
$V_{ESD}$	electrostatic discharge voltage	human body model (HBM) <sup>[1]</sup> antenna pads $L_A$ , $L_B$	-	-	+/- 4	kV
$V_{ESD}$	electrostatic discharge voltage	charged device model (CDM) <sup>[2]</sup> pads $V_{CC}$ , $V_{SS}$ , SDA, SCL, GPIO1, GPIO2, $L_A$ , $L_B$	-	-	+/- 500	V
$P_{tot}$	total power dissipation	<sup>[3]</sup>	-	-	40	mW
$T_{stg}$	storage temperature		-65	-	150	°C

[1] According to ANSI/ESDA/JEDEC JS-001

[2] According to ANSI/ESDA/JEDEC JS-002

[3] Depending on the appropriate thermal resistance of the package.

### CAUTION



This device is sensitive to ElectroStatic Discharge (ESD). Observe precautions for handling electrostatic sensitive devices.

Such precautions are described in the *ANSI/ESD S20.20*, *IEC/ST 61340-5*, *JESD625-A* or equivalent standards.

## 9 Recommended operating conditions

NTAG X DNA is characterized by its specified operating supply voltage range of 1 V to 2 V.

Table 274. Recommended operating conditions

Symbol	Parameter	Conditions	Min	Typ	Max	Unit
V <sub>CC</sub>	supply voltage	nominal Supply voltage	1	-	2	V
V <sub>I</sub>	DC input voltage on digital inputs and digital I/O pads	<sup>[1]</sup>	1 V + 10 %	-	V <sub>CC</sub> + 0.3 V	V
H	field strength	contactless interface operation	1.5	-	7.5	A/m
T <sub>amb</sub>	operating ambient temperature	<sup>[2]</sup>	-40	-	105	°C

- [1] The supply voltage operating range of 1 V to 2 V requires internal supply elevation for the supply voltage range of 1 V to 1.62 V. The supply voltage mode is automatically selected during boot-up based on internal supply voltage measurement. To avoid continuous activation and deactivation of the internal supply voltage elevation the external supply voltage of 1.55 V to 1.62 V should be avoided as performance degradation or resets might occur in this supply voltage range due to internal supply voltage switching. Performance degradation or chip resets might lead to timeouts during I<sup>2</sup>C communication. Therefore it is recommended that the host would continue to retry the read for a preset number of times in case of timeouts and after that it will go to recovery mode trying with interface/chip reset and even if there is no response, returns with an error for the application to reopen the session. The V<sub>CC</sub> supply voltage rise time impacts the power consumption. V<sub>CC</sub> supply voltage ramp times <600 μs to 1.8 V lead to higher power consumption as the device boots in voltage elevation mode. For V<sub>CC</sub> supply voltages >1.62 V the supply voltage ramp shall therefore >600 μs. The reference design recommendations of 100 nF capacitor close to VCC/VSS pin must be followed. The minimum V<sub>CC</sub> rise time (0 % - 100 %) is larger than 25 μs.
- [2] All product properties and values specified within this data sheet are only valid within the operating ambient temperature range.

### Application Remark:

In dual-interface supply scenarios where NTAG X DNA is supplied via the VCC pin and in addition the NFC field, the V<sub>CC</sub> supply must always be applied first.

In situations in which an RF field is already present before the V<sub>CC</sub> supply ramps (and NTAG X DNA is already started in contactless operation), hang-up situations might occur. In such cases a V<sub>CC</sub> power cycle is applied.

## 10 Characteristics

### 10.1 DC characteristics

#### Measurement conventions

Testing measurements are performed at the contact pads of the device under test. All voltages are defined with respect to the ground contact pad VSS. All currents flowing into the device are considered positive.

#### 10.1.1 General-purpose I/O interface

**Table 275. Electrical DC characteristics of GPIO1/2**

$V_{CC} = 1\text{ V to }2\text{ V}$  ( $V_{SS} = 0\text{ V}$ ;  $T_{amb} = -40\text{ °C to }105\text{ °C}$ , unless otherwise specified)

External pullup resistor  $20\text{ k}\Omega$  to  $V_{CC}$  assumed. The worst case test condition for parameter  $V_{OH}$  is present at minimum  $V_{CC}$ .

Symbol	Parameter	Conditions	Min	Typ	Max	Unit
$V_{IH}$	HIGH level input voltage		$0.7 \times V_{CC}$	-	$V_{CC} + 0.3$	V
$V_{IL}$	LOW level input voltage		-0.3	-	$0.25 \times V_{CC}$	V
$I_{IH}$	HIGH level input current in "weak pullup" input mode	$0.7 V_{CC} \leq V_I \leq V_{CC}$ Test conditions for the maximum absolute value: $I_{IH(max)}$ : $V_I = 0.7 V_{CC}$ ; $V_{CC} = V_{CC(max)}$	-	-1	-20	$\mu\text{A}$
$I_{IL}$	LOW level input current	$0\text{ V} \leq V_I \leq 0.3 V_{CC}$ ; Test conditions for the maximum absolute value: $I_{IL(max)}$ : $V_I = 0\text{ V}$ , $V_{CC} = V_{CC(max)}$	-	-1	-50	$\mu\text{A}$
$I_I$	Input current in "weak pullup" input mode	$0\text{ V} \leq V_I \leq V_{CC}$ ; Test conditions for the maximum absolute value: $I_I(max)$ : $V_I = 0\text{ V}$ , $V_{CC} = V_{CC(max)}$	0	-	-50	$\mu\text{A}$
$I_{ILIH}$	Leakage input current at input voltage beyond $V_{CC}$ in "weak pullup" input mode	$V_{CC} < V_I \leq V_{CC} + 0.3\text{ V}$ ; $-40\text{ °C} \leq T_{amb} \leq 105\text{ °C}$ ; Test conditions: $V_I = V_{CC} + 0.3\text{ V}$ ; $V_{CC} = V_{CC(max)}$ ; $T_{amb} = 105\text{ °C}$	-	-	20	$\mu\text{A}$
$I_{ILIL}$	Leakage input current at input voltage below $V_{SS}$ in "weak pullup" input mode	$-0.3\text{ V} \leq V_I < 0\text{ V}$ ; $-40\text{ °C} \leq T_{amb} \leq 30\text{ °C}$ Test conditions: $V_I = -0.3\text{ V}$ ; $V_{CC} = V_{CC(max)}$ ; $T_{amb} = 30\text{ °C}$	-	-	-50	$\mu\text{A}$
$V_{OH}$	HIGH level output voltage	$I_{OH} = -20\text{ }\mu\text{A}$	$0.7 \times V_{CC}$	-	-	V
$V_{OL}$	LOW level output voltage	$I_{OL} = 1\text{ mA}$ $I_{OL} = 0.5\text{ mA}$	-	-	0.3 $0.7 \times V_{CC}$	V

Conditions:

$V_{CC} = 1\text{ V to }2\text{ V}$  ( $V_{SS} = 0\text{ V}$ ;  $T_{amb} = -40\text{ }^{\circ}\text{C to }105\text{ }^{\circ}\text{C}$ , unless otherwise specified)

External pullup resistor  $20\text{ k}\Omega$  to  $V_{CC}$  assumed. The worst case test condition for parameter  $V_{OH}$  is present at minimum  $V_{CC}$ .

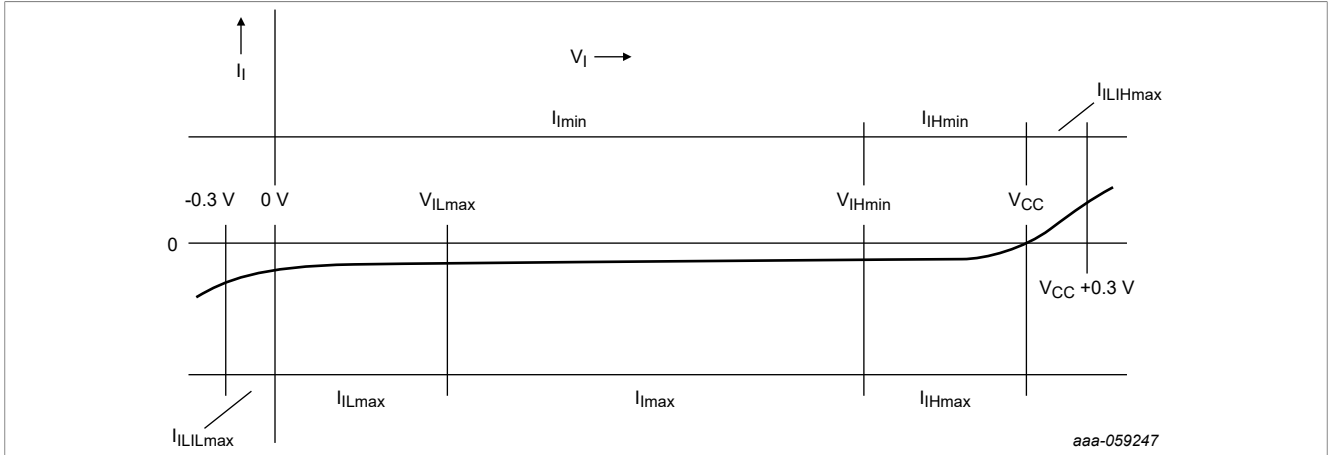

Figure 62. Input characteristics of GPIO1/2

10.1.2 I<sup>2</sup>C interface

Table 276. Electrical DC characteristics of I<sup>2</sup>C

$V_{CC} = 1\text{ V to }2\text{ V}$  ( $V_{SS} = 0\text{ V}$ ;  $T_{amb} = -40\text{ }^{\circ}\text{C to }105\text{ }^{\circ}\text{C}$ , unless otherwise specified)

Pads SCL, SDA are in open-drain mode

Symbol	Parameter	Conditions	Min	Typ	Max	Unit
$V_{IH}$	HIGH level input voltage		$0.7 \times V_{CC}$	-	$V_{CC} + 0.3$	V
$V_{IL}$	LOW level input voltage		-0.3	-	$0.25 \times V_{CC}$	V
$V_{HYS}$	input hysteresis voltage		0.081	-	-	V
$V_{OL(OD)}$	Low-level output voltage(open-drain mode)	$I_{OL} = 3\text{ mA}$	0	-	0.4	V
$I_{OL(OD)}$	Low-level output current(open-drain mode)	$V_{CC} \geq 1.1\text{ V}$	0.6	-	-	mA
$I_{WPU}$	weak pullup current	$V_{CC} \geq 1.1\text{ V}$	-	-180	-	$\mu\text{A}$
$I_{ILIH}$	leakage input current high level	$V_{SDA} = 3.6\text{ V}$ , $V_{SCL} = 3.6\text{ V}$	-	0.27	15	$\mu\text{A}$

### 10.1.3 Power Consumption

**Table 277. Electrical characteristics of IC supply voltage  $V_{CC}$**

$V_{SS} = 0\text{ V}$ ;  $T_{amb} = -40\text{ °C}$  to  $105\text{ °C}$ , unless otherwise specified

Symbol	Parameter	Conditions	Min	Typ	Max	Unit
$V_{CC}$	supply voltage range		1	-	2	V
$I_{DD}$	supply current high-performance mode, CPU halted and AES or ECC cryptographic in operation		-	-	15	mA
	supply current low-power processing mode, CPU in Idle mode and AES or ECC cryptographic in operation		-	-	0.65	mA
	supply current Halt mode		-	-	5	$\mu\text{A}$
	supply current Off state		-	-	0.25	$\mu\text{A}$

### 10.2 AC characteristics

**Table 278. Authentication application timing**

Symbol	Parameter	Conditions	Min	Typ	Max	Unit
$t_{DIT}$	Initialization time from $V_{CC}$ applied or wake from HALT mode		-	-	1	ms
$t_{AUTH1}$	Authentication time, with contact, SIGMA-I protocol		-	-	500	ms
$t_{AUTH2}$	Authentication time, with contactless, with ID1 antenna		-	-	90	ms

**Table 279. Nonvolatile memory timing characteristics**

$V_{CC} = 1\text{ V}$  to  $2\text{ V}$ ;  $V_{SS} = 0\text{ V}$ ;  $T_{amb} = -40\text{ °C}$  to  $105\text{ °C}$ , unless otherwise specified

Symbol	Parameter	Conditions	Min	Typ	Max	Unit
$t_{EEP}$	FLASH erase + program time <sup>[1]</sup>		-	-	2.3	ms
$t_{EEE}$	FLASH program time		-	-	0.9	ms
$t_{EEW}$	FLASH erase time		-	-	1.4	ms

[1] The given value specifies physical access times of FLASH memory only.

**Table 280. Nonvolatile memory data retention and endurance**

$V_{CC} = 1\text{ V}$  to  $2\text{ V}$ ;  $V_{SS} = 0\text{ V}$ ;  $T_{amb} = -40\text{ °C}$  to  $105\text{ °C}$ , unless otherwise specified

Symbol	Parameter	Conditions	Min	Typ <sup>[1]</sup>	Max	Unit
$t_{EER}$	FLASH data retention time <math>20 \times 10^3</math> erase/program cycles to the whole memory block	$T_{amb} = 55\text{ °C}$	50	-	-	years
	FLASH data retention time <math>20 \times 10^6</math> erase/program cycles to the whole memory block	$T_{amb} = 55\text{ °C}$	25	-	-	years
$N_{EEC}$	FLASH endurance (maximum number of programming cycles applied to the whole memory block performed by NXP static and dynamic wear leveling algorithm)		$20 \times 10^6$	$100 \times 10^6$	-	cycles

[1] Typical values are only referenced for information. They are subject to change without notice.

**Table 281. Electrical AC characteristics of SDA, SCL**

$V_{CC} = 1\text{ V to }2\text{ V}$ ;  $V_{SS} = 0\text{ V}$ ;  $T_{amb} = -40\text{ }^{\circ}\text{C to }105\text{ }^{\circ}\text{C}$ , unless otherwise specified <sup>[1]</sup>

SCL, SDA pads in open-drain mode.

Symbol	Parameter	Conditions	Min	Typ	Max	Unit
$t_{r_{IO}}$ <sup>[2][3]</sup>	I/O Input rise time	Input/reception mode	-	-	1	$\mu\text{s}$
$t_{f_{IO}}$ <sup>[2][4]</sup>	I/O Input fall time	Input/reception mode	-	-	1	$\mu\text{s}$
$t_{f_{OIO}}$	I/O Output fall time	Output/transmission mode; $C_L = 30\text{ pF}$	-	-	0.3	$\mu\text{s}$
$f_{CLK}$	External clock frequency in I <sup>2</sup> C applications	$t_{CLKW}$ , $T_{amb}$ and $V_{CC}$ within specified limits	-	-	1	MHz
$C_{PIN}$	Pin capacitances SDA, SCL	Test $f = 1\text{ MHz}$ ; $T_{amb} = 25\text{ }^{\circ}\text{C}$	-	-	10.5	pF
$P_{OUT}$	maximum output power in power harvesting mode at GPIO1		-	-	10	mW

[1] All appropriately marked values are typical values and only referenced for information. They are subject to change without notice.

[2] maximum recommended load 5pF

[3]  $t_r$  is defined as rise time between 30 % and 70 % of the signal amplitude.

[4]  $t_f$  is defined as fall time between 70 % and 30 % of the signal amplitude.

**Table 282. Electrical AC characteristics of LA, LB**

$V_{CC} = 1\text{ V to }2\text{ V}$ ;  $V_{SS} = 0\text{ V}$ ;  $T_{amb} = -40\text{ }^{\circ}\text{C to }105\text{ }^{\circ}\text{C}$ , unless otherwise specified

<sup>[1]</sup>

Symbol	Parameter	Conditions	Min	Typ <sup>[2]</sup>	Max	Unit
$C_{LALB}$ <sup>[3]</sup>	Configured for antenna input with 17 pF capacitance Test frequency = 13.56 MHz; $T_{amb} = 25\text{ }^{\circ}\text{C}$	$V_{LA, LB} = 2.65\text{ V (rms)}$	-	18.4	-	pF
$C_{LALB}$ <sup>[3]</sup>	Configured for antenna input with 50 pF capacitance Test frequency = 13.56 MHz; $T_{amb} = 25\text{ }^{\circ}\text{C}$	$V_{LA, LB} = 2.6\text{ V (rms)}$	-	49.7	-	pF
$R_{LALB}$ <sup>[3][4][5][6]</sup>	Configured for antenna input with 17 pF capacitance. Test frequency = 13.56 MHz; $T_{amb} = 25\text{ }^{\circ}\text{C}$	$V_{LA, LB} = 1.94\text{ V (rms)}$	-	1.5	-	k $\Omega$
$R_{LALB}$ <sup>[3][7][5][6]</sup>	Configured for antenna input with 50 pF capacitance. Test frequency = 13.56 MHz; $T_{amb} = 25\text{ }^{\circ}\text{C}$	$V_{LA, LB} = 1.94\text{ V (rms)}$	-	1.4	-	k $\Omega$
$f_{LALB}$	operating frequency $L_A, L_B$		-	13.56	-	MHz

[1] All measurements performed for with WLCSP package mounted on TLB

[2] Typical values are only referenced for information. They are subject to change without notice.

[3]  $C_{LALB}$  and  $R_{LALB}$  values stated here assume a parallel RC equivalent circuit for the chip.

[4] The value stated here was measured at estimated start of chip operation and is comparable to the values stated in other SmartMX3 family member data.

[5] Measured with sine wave at  $L_A, L_B$ .

[6] Parameter is valid in contactless ISO14443 compliant operation valid only.

[7] The value stated here was measured at estimated start of chip operation.

### 10.3 I<sup>2</sup>C Bus Timings

The NTAG X DNA I<sup>2</sup>C bus timing parameters are in accordance to the NXP I<sup>2</sup>C bus specification, see [Section 13](#).

### 10.4 EMC/EMI

EMC and EMI resistance according to IEC 61967-4, see [Section 13](#).

## 11 Package information

NTAG X DNA is either offered as Wafer Level Chip-Scale Package (WLCSP), Sawn Wafer on FFC, or HVQFN.

### 11.1 WLCSP 16

NTAG X DNA is provided in a four by four ball grid Wafer Level Chip-Scale Package (WLCSP):

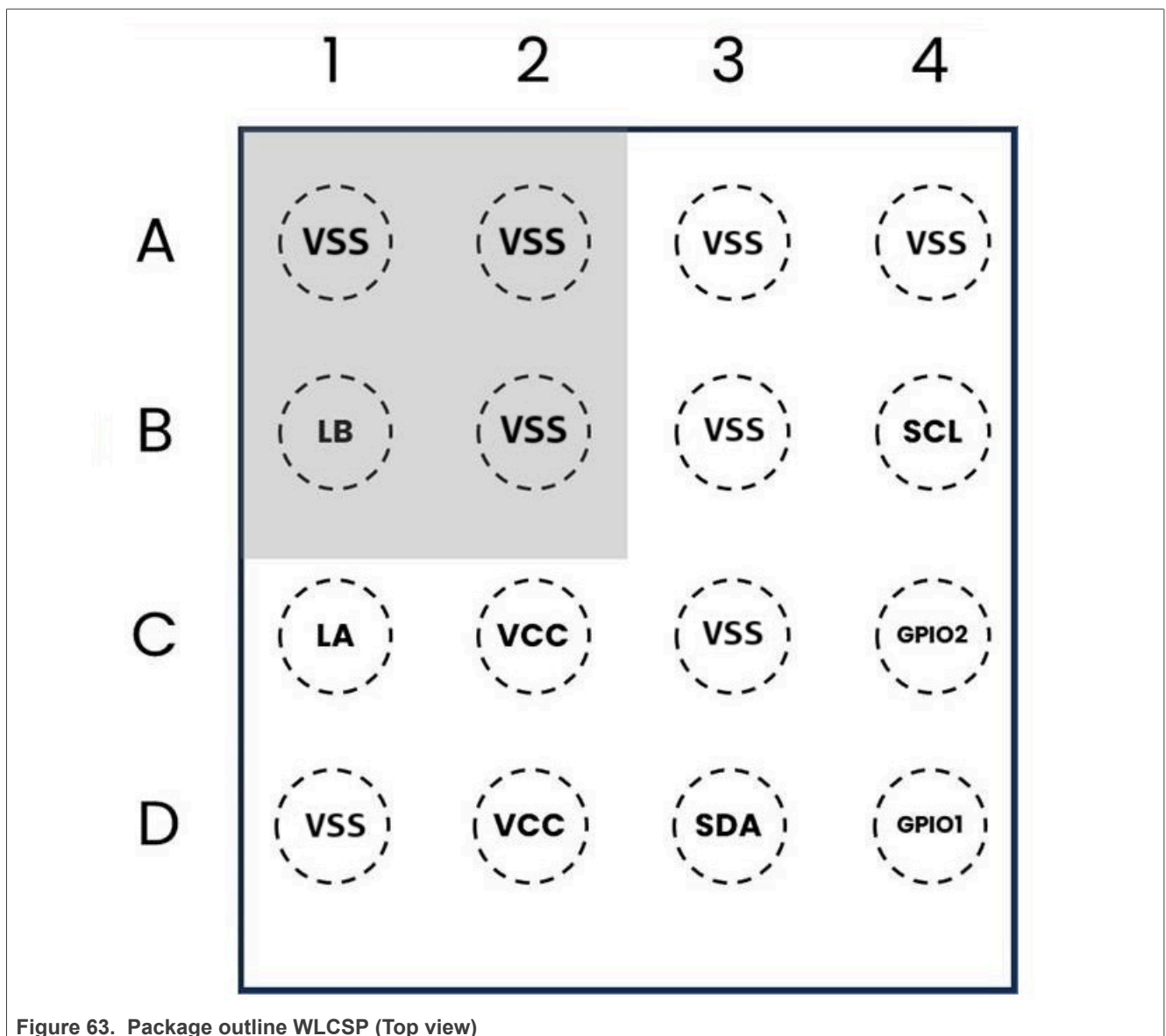

Figure 63. Package outline WLCSP (Top view)

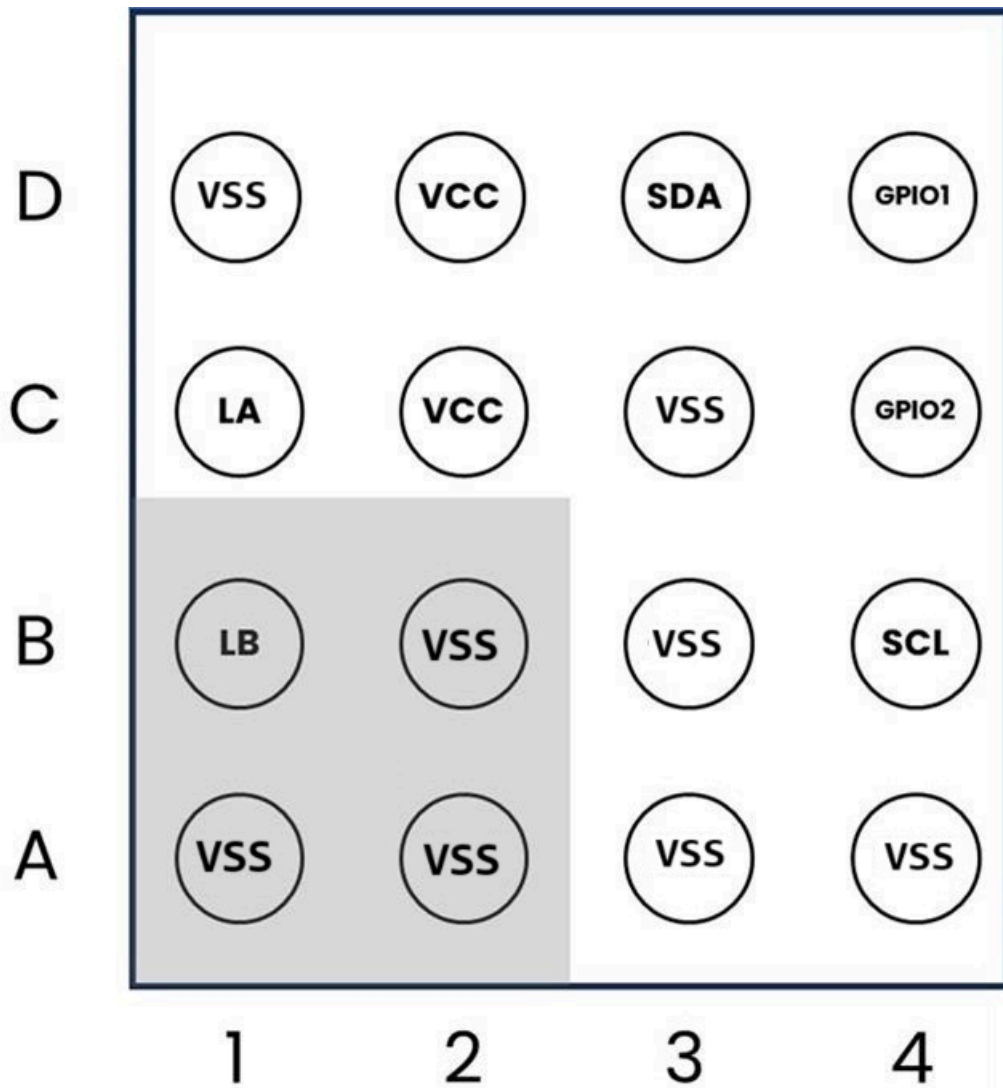

Figure 64. Package outline WLCSP (Bottom view)

WLCSP thickness is  $\leq 0.5$  mm with a ball pitch is 0.35 mm. A detailed description including pins can be found in "Delivery Specification [\[12\]](#)"

11.2 HVQFN 20

NTAG X DNA is provided in HVQFN:

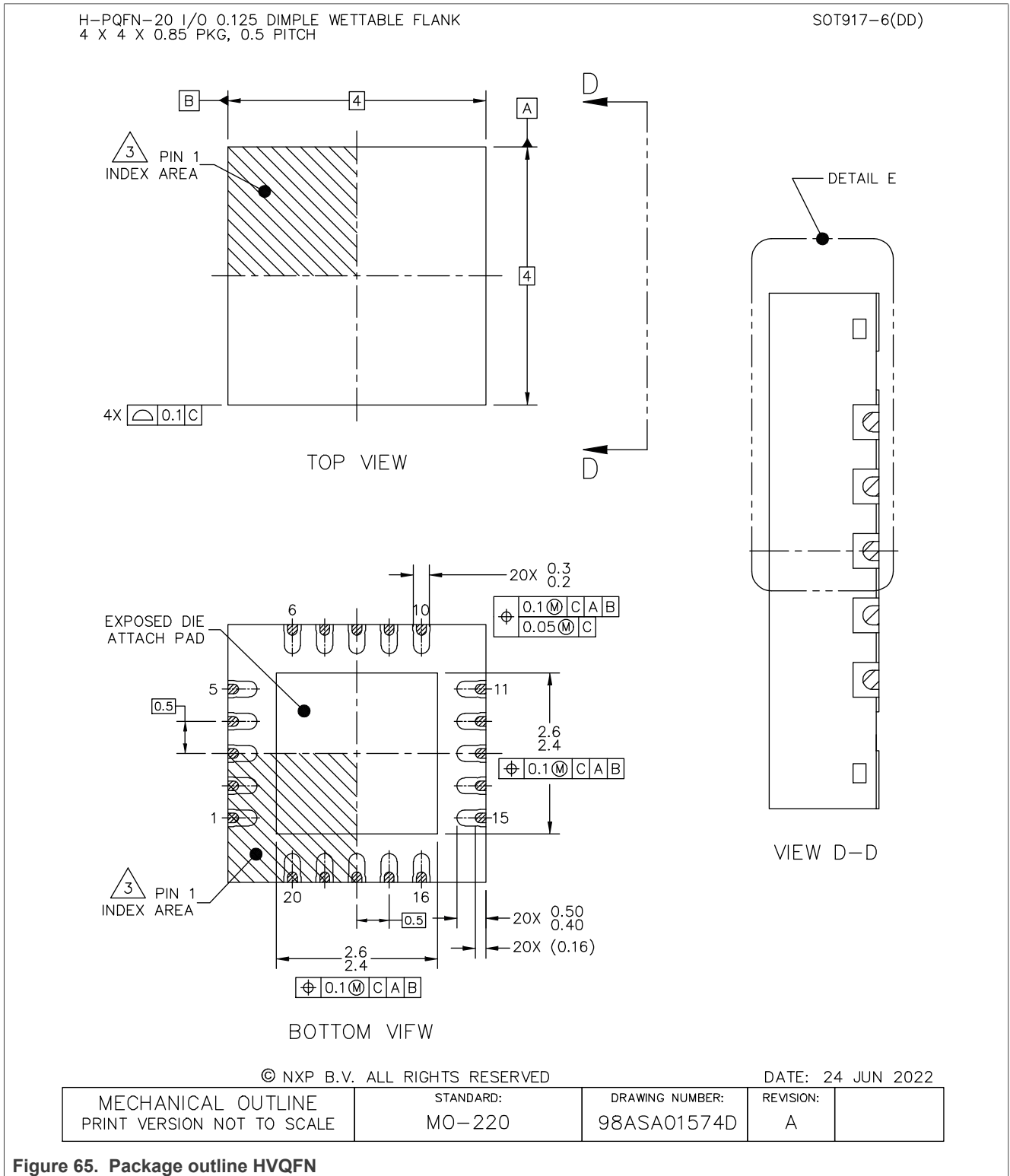

Figure 65. Package outline HVQFN

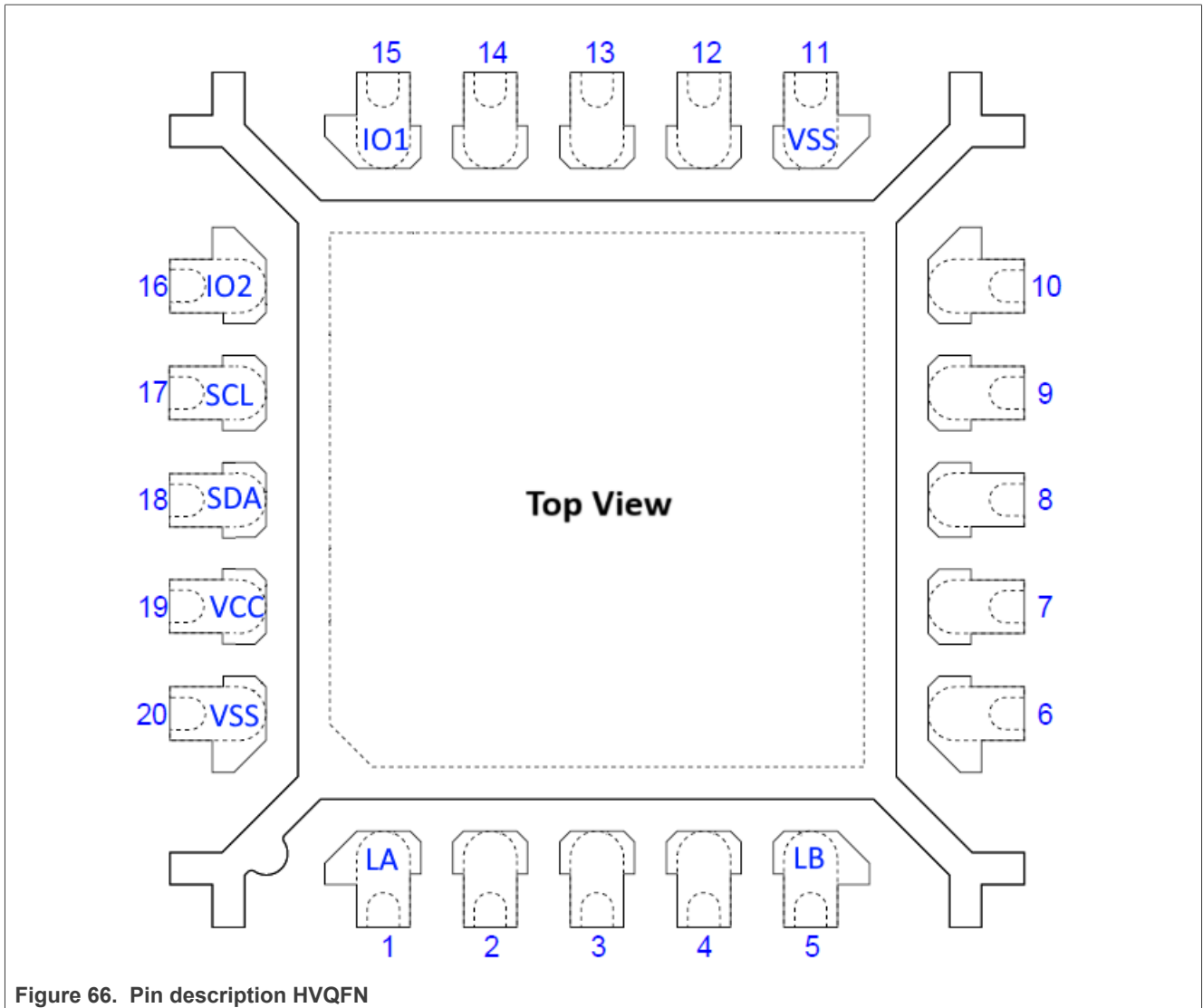

Figure 66. Pin description HVQFN

HVQFN thickness is 0.85 mm with a pitch is 0.5 mm. A detailed description can be found in "Delivery Specification [\[12\]](#)"

### 11.3 Sawn wafer

NTAG X DNA is offered on 12-inch wafer (sawn, 120 µm thickness, on film frame carrier; electronic fail die marking according to SECSII format) wafer delivery. With this delivery type, only 4 pins would be available for the contactless labels without I<sup>2</sup>C. A detailed description including pad coordinates is part of the "Delivery Specification [\[12\]](#)"

## 12 Abbreviations

Table 283. Abbreviations

Acronym	Description
AES	Advanced Encryption Standard
APDU	Application Protocol Data unit
AppKey	Application Key
AppMasterKey	Application Master Key
API	Application Programming Interface
ASCII	American Standard Code for Information Interchange
ATQA	Answer to Request A
ATS	Answer to Select
CA	Certificate Authority
C-APDU	Command APDU
CBC	Cipher Block Chaining
CC	Capability Container
CCM	Counter with Cipher Block Chaining Message Authentication Code (CBC-MAC)
CID	Channel Identifier
CLA	Class
CMAC	Cipher-based Message Authentication Code
CmdCtr	Command Counter
CRC	Cyclic Redundancy Check
DF	Dedicated File (Application)
EAL	Evaluation Assurance Level
ECB	Electronic Code Book mode
ECC	Error Correcting Code
ECDH	Elliptic-curve Diffie Hellman
EF	Elementary File (File)
FCI	File Control Information
FSC	Frame Size for proximity Card (according to ISO/IEC 14443-4)
GPIO	General-Purpose Input/Output
HWDT	Halt WatchDog Timer
INS	INstruction byte (according to ISO/IEC 7816-4)
IV	Initialization Vector
KDF	Key Derivation Function
LSB	Least Significant Byte
MAC	Message Authentication Code
MCU	Microcontroller Unit

Table 283. Abbreviations...continued

Acronym	Description
MF	Master File
MSB	Most Significant Byte
NDEF	NFC Data Exchange Format
NFC	Near-Field Communication
NVM	Non-Volatile Memory
OID	Object Identifier
PCB	Printed-Circuit Board
PCD	Proximity Coupling Device (Contactless Reader)
PCDCap	Proximity Coupling Device Capabilities
PD	Proximity Device, used as synonym for the PICC
PDCap	Proximity Device Capabilities
PICC	Proximity IC Card
PICCData	PICC data targeted for mirroring (e.g. UID, SDMReadCtr)
PKI	Public Key Infrastructure
POR	power-on-reset
PPS	Protocol Parameter Select
PRF	Pseudo-Random Function
PST	Power-Saving Time-out
RATS	Request for Answer To Select
RC	Return Code
RFU	Reserved for Future Use
RNG	Random Number Generator
SAK	Select Acknowledge
SDA	Serial Data
SDM	Secure Dynamic Messaging
SDMctrRet	SDM Counter Retrieval, access right for GetFileCounters
SDMENCFileData	Refers to the encrypted part of data in the NDEF file
SDMFileRead	SDM File Reading, key/access setting for Secure Dynamic Messaging
SDMFileReadKey	Refers to the AppKey which is used for SDM MAC calculation
SDMMAC	Refers to the MAC calculated over response
SDMMetaRead	SDM Meta Reading, specifies PICCData encryption key or plain mirroring
SDMMetaReadKey	Refers to the AppKey which is used for SDM encryption of PICCData
SDMReadCtr	SDM Read Counter, counting number of interactions with a PICC
SesAuthENCKey	Session key for encryption
SesAuthMACKey	Session key for MACing
SP	Special Publication

Table 283. Abbreviations...continued

Acronym	Description
SPI	Serial Peripheral Interface
SUN	Secure Unique NFC
SV	Session Vector, input for session key calculation
SW	Status Word
TI	Transaction Identifier
TT	Tag Tamper
TTCurrStatus	Current status of the Tag Tamper loop
TTPermStatus	Permanently stores an Open status on the Tag Tamper loop
UID	Unique IDentifier
URI	Uniform Resource Identifier
WLCSP	Wafer Level Chip Sale Package

## 13 References

- [1] User Manual - UM12053 - NRV11 Information on Guidance and Operation, Doc. No. UM9763\*\*<sup>2</sup>
- [2] Specification - ISO/IEC 14443-2:2016 - Identification cards -- Contactless integrated circuit cards -- Proximity cards -- Part 2: Radio frequency power and signal interface
- [3] Specification - ISO/IEC 14443-3:2018 - Identification cards -- Contactless integrated circuit cards -- Proximity cards -- Part 3: Initialization and anti-collision
- [4] Specification - ISO/IEC 14443-4:2018 - Identification cards -- Contactless integrated circuit cards -- Proximity cards -- Part 4: Transmission protocol
- [5] Specification - ISO/IEC 7816-4:2020 - Identification cards – Integrated circuit cards – Part 4: Organization, security and commands for interchange
- [6] Standard - FIPS PUB 197 - FEDERAL INFORMATION PROCESSING STANDARDS PUBLICATION, ADVANCED ENCRYPTION STANDARD (AES), National Institute of Standards and Technology, 2001 November 26
- [7] Recommendation - NIST Special Publication 800-38A - National Institute of Standards and Technology (NIST). Recommendation for BlockCipher Modes of Operation ([link](#))
- [8] Recommendation - NIST Special Publication 800-38B - National Institute of Standards and Technology (NIST). Recommendation for Block Cipher Modes of Operation: The CMAC Mode for Authentication ([link](#))
- [9] Specification - ISO/IEC 9797-1:1999 - Information technology – Security techniques – Message Authentication Codes (MACs) – Part 1: Mechanisms using a block cipher.
- [10] Recommendation - NIST Special Publication 800-108 - National Institute of Standards and Technology (NIST). Recommendation for key derivation using pseudorandom functions.
- [11] Standard - IEEE Std 802.3-2008 - IEEE Standard for Information technology - Telecommunications and information exchange between systems - Local and metropolitan area networks - Specific requirements Part 3: Carrier sense multiple access with Collision Detection (CSMA/CD) Access Method and Physical Layer Specifications.
- [12] Data sheet addendum - NTAG X DNA - Delivery specification, Document number AD9772\*\*
- [13] Document - Certicom Research. Sec 1 - Elliptic curve cryptography. Version 2.0, May 2009.
- [14] Product data sheet - NTAG213/215/216: NFC Forum Type 2 Tag compliant IC with 144/504/888 bytes user memory, Document number 2653\*\*
- [15] Specification - NFC Forum: Type 4 Tag, Version 1.0 - [T4T] - 26 July 2016.
- [16] Specification - NFC Data Exchange Format (NDEF) - NFC Forum - Technical Specification - Version 1.0 - 24.07.2006
- [17] User manual - UM10204 I2C-bus specification and user manual, Rev. 7, 10 2021.
- [18] Document - Globalplatform technology - apdu transport over spi / i2c - version 1.0. Version 1.0, January 2020
- [19] Standard - National Institute of Standards and Technology (NIST) - Federal Information Processing Standard (FIPS) 180- 4: Secure Hash Standard (SHS). NIST FIPS PUB 180-4, August 2015.
- [20] Specification - ISO/IEC 8825-1:2015 - ISO JTC 1/SC 6. Information technology - ASN.1 encoding rules: Specification of Basic Encoding Rules (BER), Canonical Encoding Rules (CER) and Distinguished Encoding Rules (DER). ISO/IEC 8825-1:2015, November 2015.
- [21] Specification - ISO/IEC 9798-3:2019 - ISO JTC 1/SC 27. Information technology – Security techniques – Entity authentication – Part 3: Mechanisms using digital signature techniques. ISO/IEC 9798-3:2019, 2019.
- [22] Standard - IEEE Std 802.3-2008 - IEEE Computer Society. IEEE Standard for Information Technology - Telecommunications and information exchange between systems - Local and metropolitan area networks - Specific requirements Part 3: Carrier sense multiple access with Collision Detection (CSMA/CD) Access Method and Physical Layer Specifications. IEEE Std 802.3-2008, December 2008.
- [23] Specification - Matter Specification, Version 1.0, 09 2022.

<sup>2</sup> \*\* ... document version number

- [24] Document - Proposal for: Functionality classes for random number generators - A proposal for: Functionality classes for random number generators, Wolfgang Killmann, T-Systems GEI GmbH, Werner Schindler, Bundesamt für Sicherheit in der Informationstechnik (BSI), Version 2.0, 18 September 2011
- [25] Document - BSI-CC-PP-0084-2014 - Security IC Platform Protection Profile with Augmentation Packages, Registered and Certified by Bundesamt für Sicherheit in der Informationstechnik (BSI) under the reference BSI-CC-PP-0084-2014, Version 1.0, 13 January 2014.
- [26] Standard - FIPS PUB 186-5 - Digital Signature Standard (DSS), Federal Information Processing Standards Publication, US Department of Commerce/National Institute of Standards and Technology, October 2019.
- [27] Standard - FIPS PUB 198-1 - The Keyed-Hash Message Authentication Code (HMAC), Federal Information Processing Standards Publication 198-1, US Department of Commerce/ National Institute of Standards and Technology, July 2008
- [28] Recommendation - NIST SP 800-38C - Recommendation for Block Cipher Modes of Operation: The CCM Mode for Authentication and Confidentiality, Morris Dworkin, National Institute of Standards and Technology, May 2004.
- [29] Recommendation - NIST SP 800-38D - Recommendation for Block Cipher Modes of Operation: Galois/Counter Mode (GCM) and GMAC, Morris Dworkin, National Institute of Standards and Technology, November 2007.
- [30] Recommendation - NIST SP 800-56A - Recommendation for Pair-Wise Key-Establishment Schemes Using Discrete Logarithm Cryptography, National Institute of Standards and Technology, April 2018.
- [31] Document - RFC 5869 - RFC 5869: HMAC-based Extract-and-Expand Key Derivation Function (HKDF), Internet Engineering Task Force (IETF), Request For Comments, May 2010.
- [32] Specification - ISO/IEC 9594-8 - Information technology - Open systems interconnection - Part 8: The Directory: Public key and attribute certificate frameworks - Ninth edition, 11 2020.

## 14 Note about the source code in the document

---

Example code shown in this document has the following copyright and BSD-3-Clause license:

Copyright 2024-2026 NXP Redistribution and use in source and binary forms, with or without modification, are permitted provided that the following conditions are met:

1. Redistributions of source code must retain the above copyright notice, this list of conditions and the following disclaimer.
2. Redistributions in binary form must reproduce the above copyright notice, this list of conditions and the following disclaimer in the documentation and/or other materials must be provided with the distribution.
3. Neither the name of the copyright holder nor the names of its contributors may be used to endorse or promote products derived from this software without specific prior written permission.

THIS SOFTWARE IS PROVIDED BY THE COPYRIGHT HOLDERS AND CONTRIBUTORS "AS IS" AND ANY EXPRESS OR IMPLIED WARRANTIES, INCLUDING, BUT NOT LIMITED TO, THE IMPLIED WARRANTIES OF MERCHANTABILITY AND FITNESS FOR A PARTICULAR PURPOSE ARE DISCLAIMED. IN NO EVENT SHALL THE COPYRIGHT HOLDER OR CONTRIBUTORS BE LIABLE FOR ANY DIRECT, INDIRECT, INCIDENTAL, SPECIAL, EXEMPLARY, OR CONSEQUENTIAL DAMAGES (INCLUDING, BUT NOT LIMITED TO, PROCUREMENT OF SUBSTITUTE GOODS OR SERVICES; LOSS OF USE, DATA, OR PROFITS; OR BUSINESS INTERRUPTION) HOWEVER CAUSED AND ON ANY THEORY OF LIABILITY, WHETHER IN CONTRACT, STRICT LIABILITY, OR TORT (INCLUDING NEGLIGENCE OR OTHERWISE) ARISING IN ANY WAY OUT OF THE USE OF THIS SOFTWARE, EVEN IF ADVISED OF THE POSSIBILITY OF SUCH DAMAGE.

## 15 Revision history

Table 284. Revision history

Document ID	Release date	Description
NTAG_X_DNA v.3.2	6 July 2026	Product data sheet. <ul style="list-style-type: none"> <li>• <a href="#">Section 1 "General description"</a>: updated.</li> <li>• <a href="#">Section 13</a>: updated.</li> </ul>
NTAG_X_DNA v.3.1	25 June 2026	Product data sheet. <ul style="list-style-type: none"> <li>• Editorial changes (typos, etc.).</li> <li>• Clarification on the GPIO usage.</li> <li>• Corrected AC characteristics.</li> <li>• Added HVQFN package with pin names.</li> </ul>
NTAG_X_DNA v.3.0	27 May 2025	Product data sheet. Editorial changes (typos, etc.). Document security status changed to "public". <ul style="list-style-type: none"> <li>• <a href="#">Section 6.19 "Security"</a>: added.</li> <li>• <a href="#">Section 11.2 "HVQFN 20"</a>: updated.</li> </ul>
NTAG_X_DNA v.2.0	18 October 2024	Preliminary data sheet.
NTAG_X_DNA v.1.0	31 July 2024	Objective data sheet.

Legal information

Data sheet status

Document status <sup>[1][2]</sup>	Product status <sup>[3]</sup>	Definition
Objective [short] data sheet	Development	This document contains data from the objective specification for product development.
Preliminary [short] data sheet	Qualification	This document contains data from the preliminary specification.
Product [short] data sheet	Production	This document contains the product specification.

- [1] Please consult the most recently issued document before initiating or completing a design.
- [2] The term 'short data sheet' is explained in section "Definitions".
- [3] The product status of device(s) described in this document may have changed since this document was published and may differ in case of multiple devices. The latest product status information is available on the Internet at URL <https://www.nxp.com>.

Definitions

**Draft** — A draft status on a document indicates that the content is still under internal review and subject to formal approval, which may result in modifications or additions. NXP Semiconductors does not give any representations or warranties as to the accuracy or completeness of information included in a draft version of a document and shall have no liability for the consequences of use of such information.

**Short data sheet** — A short data sheet is an extract from a full data sheet with the same product type number(s) and title. A short data sheet is intended for quick reference only and should not be relied upon to contain detailed and full information. For detailed and full information see the relevant full data sheet, which is available on request via the local NXP Semiconductors sales office. In case of any inconsistency or conflict with the short data sheet, the full data sheet shall prevail.

**Product specification** — The information and data provided in a Product data sheet shall define the specification of the product as agreed between NXP Semiconductors and its customer, unless NXP Semiconductors and customer have explicitly agreed otherwise in writing. In no event however, shall an agreement be valid in which the NXP Semiconductors product is deemed to offer functions and qualities beyond those described in the Product data sheet.

Disclaimers

**Limited warranty and liability** — Information in this document is believed to be accurate and reliable. However, NXP Semiconductors does not give any representations or warranties, expressed or implied, as to the accuracy or completeness of such information and shall have no liability for the consequences of use of such information. NXP Semiconductors takes no responsibility for the content in this document if provided by an information source outside of NXP Semiconductors.

In no event shall NXP Semiconductors be liable for any indirect, incidental, punitive, special or consequential damages (including - without limitation - lost profits, lost savings, business interruption, costs related to the removal or replacement of any products or rework charges) whether or not such damages are based on tort (including negligence), warranty, breach of contract or any other legal theory.

Notwithstanding any damages that customer might incur for any reason whatsoever, NXP Semiconductors' aggregate and cumulative liability towards customer for the products described herein shall be limited in accordance with the Terms and conditions of commercial sale of NXP Semiconductors.

**Right to make changes** — NXP Semiconductors reserves the right to make changes to information published in this document, including without limitation specifications and product descriptions, at any time and without notice. This document supersedes and replaces all information supplied prior to the publication hereof.

**Suitability for use** — NXP Semiconductors products are not designed, authorized or warranted to be suitable for use in life support, life-critical or safety-critical systems or equipment, nor in applications where failure or malfunction of an NXP Semiconductors product can reasonably be expected to result in personal injury, death or severe property or environmental damage. NXP Semiconductors and its suppliers accept no liability for inclusion and/or use of NXP Semiconductors products in such equipment or applications and therefore such inclusion and/or use is at the customer's own risk.

**Applications** — Applications that are described herein for any of these products are for illustrative purposes only. NXP Semiconductors makes no representation or warranty that such applications will be suitable for the specified use without further testing or modification.

Customers are responsible for the design and operation of their applications and products using NXP Semiconductors products, and NXP Semiconductors accepts no liability for any assistance with applications or customer product design. It is customer's sole responsibility to determine whether the NXP Semiconductors product is suitable and fit for the customer's applications and products planned, as well as for the planned application and use of customer's third party customer(s). Customers should provide appropriate design and operating safeguards to minimize the risks associated with their applications and products.

NXP Semiconductors does not accept any liability related to any default, damage, costs or problem which is based on any weakness or default in the customer's applications or products, or the application or use by customer's third party customer(s). Customer is responsible for doing all necessary testing for the customer's applications and products using NXP Semiconductors products in order to avoid a default of the applications and the products or of the application or use by customer's third party customer(s). NXP does not accept any liability in this respect.

**Limiting values** — Stress above one or more limiting values (as defined in the Absolute Maximum Ratings System of IEC 60134) will cause permanent damage to the device. Limiting values are stress ratings only and (proper) operation of the device at these or any other conditions above those given in the Recommended operating conditions section (if present) or the Characteristics sections of this document is not warranted. Constant or repeated exposure to limiting values will permanently and irreversibly affect the quality and reliability of the device.

**Terms and conditions of commercial sale** — NXP Semiconductors products are sold subject to the general terms and conditions of commercial sale, as published at <https://www.nxp.com/profile/terms>, unless otherwise agreed in a valid written individual agreement. In case an individual agreement is concluded only the terms and conditions of the respective agreement shall apply. NXP Semiconductors hereby expressly objects to applying the customer's general terms and conditions with regard to the purchase of NXP Semiconductors products by customer.

**No offer to sell or license** — Nothing in this document may be interpreted or construed as an offer to sell products that is open for acceptance or the grant, conveyance or implication of any license under any copyrights, patents or other industrial or intellectual property rights.

## Secure NFC T4T compliant IC for PKI (Public Key Infrastructure)

**Quick reference data** — The Quick reference data is an extract of the product data given in the Limiting values and Characteristics sections of this document, and as such is not complete, exhaustive or legally binding.

**Export control** — This document as well as the item(s) described herein may be subject to export control regulations. Export might require a prior authorization from competent authorities.

**Suitability for use in non-automotive qualified products** — Unless this document expressly states that this specific NXP Semiconductors product is automotive qualified, the product is not suitable for automotive use. It is neither qualified nor tested in accordance with automotive testing or application requirements. NXP Semiconductors accepts no liability for inclusion and/or use of non-automotive qualified products in automotive equipment or applications.

In the event that customer uses the product for design-in and use in automotive applications to automotive specifications and standards, customer (a) shall use the product without NXP Semiconductors' warranty of the product for such automotive applications, use and specifications, and (b) whenever customer uses the product for automotive applications beyond NXP Semiconductors' specifications such use shall be solely at customer's own risk, and (c) customer fully indemnifies NXP Semiconductors for any liability, damages or failed product claims resulting from customer design and use of the product for automotive applications beyond NXP Semiconductors' standard warranty and NXP Semiconductors' product specifications.

**HTML publications** — An HTML version, if available, of this document is provided as a courtesy. Definitive information is contained in the applicable document in PDF format. If there is a discrepancy between the HTML document and the PDF document, the PDF document has priority.

**Translations** — A non-English (translated) version of a document, including the legal information in that document, is for reference only. The English version shall prevail in case of any discrepancy between the translated and English versions.

**Security** — Customer understands that all NXP products may be subject to unidentified vulnerabilities or may support established security standards or specifications with known limitations. Customer is responsible for the design and operation of its applications and products throughout their lifecycles to reduce the effect of these vulnerabilities on customer's applications and products. Customer's responsibility also extends to other open and/or proprietary technologies supported by NXP products for use in customer's applications. NXP accepts no liability for any vulnerability. Customer should regularly check security updates from NXP and follow up appropriately.

Customer shall select products with security features that best meet rules, regulations, and standards of the intended application and make the ultimate design decisions regarding its products and is solely responsible for compliance with all legal, regulatory, and security related requirements concerning its products, regardless of any information or support that may be provided by NXP.

NXP has a Product Security Incident Response Team (PSIRT) (reachable at [PSIRT@nxp.com](mailto:PSIRT@nxp.com)) that manages the investigation, reporting, and solution release to security vulnerabilities of NXP products.

**NXP B.V.** — NXP B.V. is not an operating company and it does not distribute or sell products.

## Trademarks

Notice: All referenced brands, product names, service names, and trademarks are the property of their respective owners.

**NXP** — wordmark and logo are trademarks of NXP B.V.

**Bluetooth** — the Bluetooth wordmark and logos are registered trademarks owned by Bluetooth SIG, Inc. and any use of such marks by NXP Semiconductors is under license.

**I2C-bus** — logo is a trademark of NXP B.V.

**Matter, Zigbee** — are developed by the Connectivity Standards Alliance. The Alliance's Brands and all goodwill associated therewith, are the exclusive property of the Alliance.

**MIFARE** — is a trademark of NXP B.V.

**NTAG** — is a trademark of NXP B.V.

**SmartMX** — is a trademark of NXP B.V.

Tables

Tab. 1.	Ordering information	6	Tab. 47.	Response description - ISOGeneralAuthenticate	108
Tab. 2.	NTAG X DNA pin configuration	8	Tab. 48.	Error code description - ISOGeneralAuthenticate	108
Tab. 3.	ATS value	9	Tab. 49.	Command summary - ISOInternalAuthenticate	109
Tab. 4.	I2C communication interface parameters	11	Tab. 50.	Command Description - ISOInternalAuthenticate	109
Tab. 5.	ISO/IEC 7816-4 command fields	13	Tab. 51.	Response description - ISOInternalAuthenticate	110
Tab. 6.	ISO/IEC 7816-4 response fields	13	Tab. 52.	Error code description - ISOInternalAuthenticate	110
Tab. 7.	SIGMA-I Session Keys	17	Tab. 53.	Command summary - AuthenticateEV2First	111
Tab. 8.	SIGMA-I Message Types	17	Tab. 54.	Command description - AuthenticateEV2First - Part1	112
Tab. 9.	Asymmetric authentication Protocols Payload Encodings	18	Tab. 55.	Response description - AuthenticateEV2First - Part1	112
Tab. 10.	NTAG X DNA as SIGMA-I responder	19	Tab. 56.	Error code description - AuthenticateEV2First - Part1	112
Tab. 11.	NTAG X DNA as SIGMA-I initiator	20	Tab. 57.	Command description - AuthenticateEV2First - Part2	113
Tab. 12.	SIGMA-I Session Key Sizes	21	Tab. 58.	Response description - AuthenticateEV2First - Part2	113
Tab. 13.	ECC-basedcard-unilateral authentication	25	Tab. 59.	Error code description - AuthenticateEV2First - Part2	113
Tab. 14.	When to use which authentication command	26	Tab. 60.	Command summary - AuthenticateEV2NonFirst	114
Tab. 15.	Supported communication modes	32	Tab. 61.	Command description - AuthenticateEV2NonFirst - Part1	114
Tab. 16.	PICCCData: plain encoding and lengths	37	Tab. 62.	Response description - AuthenticateEV2NonFirst - Part1	114
Tab. 17.	PICCCDataTag	38	Tab. 63.	Error code description - AuthenticateEV2NonFirst - Part1	115
Tab. 18.	Access condition values coded on 4 bits	44	Tab. 64.	Command description - AuthenticateEV2NonFirst - Part2	115
Tab. 19.	ACMap encoding	45	Tab. 65.	Response description - AuthenticateEV2NonFirst - Part2	115
Tab. 20.	Application access rights, specified via DFName	46	Tab. 66.	Error code description - AuthenticateEV2NonFirst - Part2	115
Tab. 21.	Application access rights, specified via DFName	47	Tab. 67.	Command summary - ProcessSM	116
Tab. 22.	Manufacturer characteristics used as card version	49	Tab. 68.	Command Description - ProcessSM	116
Tab. 23.	DeferralItem	50	Tab. 69.	Response Description - ProcessSM	116
Tab. 24.	SetConfiguration options list	51	Tab. 70.	Error code description - ProcessSM	116
Tab. 25.	ProtocolOptions	60	Tab. 71.	Command summary - ProcessSM_Apply	117
Tab. 26.	GPIOxConfig	61	Tab. 72.	Command Description - ProcessSM_Apply	117
Tab. 27.	GPIOxPadCtrl	62	Tab. 73.	Response Description - ProcessSM_Apply	118
Tab. 28.	Supported memory configurations	65	Tab. 74.	Error code description - ProcessSM_Apply	118
Tab. 29.	Supported key types	66	Tab. 75.	Command summary - ProcessSM_Remove	118
Tab. 30.	Keys at application level	66	Tab. 76.	Command Description - ProcessSM_Remove	119
Tab. 31.	GetKeySettings Key Groups	69	Tab. 77.	Response Description - ProcessSM_Remove	119
Tab. 32.	Certificate Cache Example	73	Tab. 78.	Error code description - ProcessSM_Remove	119
Tab. 33.	X.509 Certificate Wrap Encoding	76	Tab. 79.	Command summary - FreeMem	120
Tab. 34.	Set of Access condition coded on 2 bytes	78	Tab. 80.	Command description - FreeMem	120
Tab. 35.	FileAR.SDMMetaRead values	79			
Tab. 36.	FileAR.SDMFileRead values	79			
Tab. 37.	FileAR.SDMFileRead2 values	79			
Tab. 38.	FileAR.SDMFileRead and FileAR.SDMFileRead2 combinations	80			
Tab. 39.	Command list associated with access rights	80			
Tab. 40.	Crypto API Data Source/Destination Selection	89			
Tab. 41.	Crypto API Slot Usage Policy Options	89			
Tab. 42.	Crypto API Policy Supported Algorithms	89			
Tab. 43.	ReadGPIO response	94			
Tab. 44.	APDUs	106			
Tab. 45.	Command summary - ISOGeneralAuthenticate	108			
Tab. 46.	Command description - ISOGeneralAuthenticate	108			

Tab. 81.	Response description - FreeMem - OPERATION_OK .....	120	Tab. 124.	Response description - ManageKeyPair .....	139
Tab. 82.	Error code description - FreeMem .....	120	Tab. 125.	Error code description - ManageKeyPair .....	139
Tab. 83.	Command Description - SetConfiguration .....	121	Tab. 126.	ManageCARootKey .....	140
Tab. 84.	Command description - SetConfiguration .....	121	Tab. 127.	Command Description - ManageCARootKey .....	140
Tab. 85.	Response description - SetConfiguration .....	122	Tab. 128.	Response description - ManageCARootKey .....	141
Tab. 86.	Error code description - SetConfiguration .....	122	Tab. 129.	Error code description - ManageKeyPair .....	141
Tab. 87.	Command summary - GetConfiguration .....	123	Tab. 130.	Command Description - ManageCertRepo .....	142
Tab. 88.	Command Description - GetConfiguration .....	123	Tab. 131.	ManageCertRepo - Create Certificate Repository .....	143
Tab. 89.	Response description - GetConfiguration .....	124	Tab. 132.	ManageCertRepo - Load Certificate .....	143
Tab. 90.	Error code description - GetConfiguration .....	124	Tab. 133.	ManageCertRepo - Load Certificate Mapping info .....	144
Tab. 91.	Command summary - ActivateConfiguration .....	125	Tab. 134.	ManageCertRepo - Reset Certificate Repository .....	144
Tab. 92.	Command Description - ActivateConfiguration .....	125	Tab. 135.	ManageCertRepo - Error Conditions .....	144
Tab. 93.	Response description - ActivateConfiguration .....	125	Tab. 136.	Command Description - ReadCertRepo .....	145
Tab. 94.	Error code description - ActivateConfiguration .....	126	Tab. 137.	ReadCertRepo - Response Data Format for Metadata .....	145
Tab. 95.	Command summary - GetVersion .....	126	Tab. 138.	ReadCertRepo - Response Data Format for Certificate .....	146
Tab. 96.	Command parameters description - GetVersion - Part1 .....	126	Tab. 139.	Error Code Description - ReadCertRepo .....	146
Tab. 97.	Response description - GetVersion - Part1 .....	127	Tab. 140.	Command Description - CreateStdDataFile ..	147
Tab. 98.	Command parameters description - GetVersion - Part2 .....	127	Tab. 141.	Command description - CreateStdDataFile ..	147
Tab. 99.	Response description - GetVersion - Part2 .....	127	Tab. 142.	Response description - CreateStdDataFile ..	148
Tab. 100.	Command parameters description - GetVersion - Part3 .....	128	Tab. 143.	Error code description - CreateStdDataFile ..	148
Tab. 101.	Response description - GetVersion - Part3 .....	128	Tab. 144.	CreateCounterFile .....	149
Tab. 102.	Error code description - GetVersion .....	129	Tab. 145.	Command Description - CreateCounterFile ..	149
Tab. 103.	Command summary - GetCardUID .....	129	Tab. 146.	Response description - CreateCounterFile .....	150
Tab. 104.	Command parameters description - GetCardUID .....	129	Tab. 147.	Error code description - CreateCounterFile ..	150
Tab. 105.	Response description - GetCardUID .....	129	Tab. 148.	Command Description - GetFileIDs .....	150
Tab. 106.	Error code description - GetCardUID .....	130	Tab. 149.	Command description - GetFileIDs .....	150
Tab. 107.	Command summary - ChangeKey .....	130	Tab. 150.	Response description - GetFileIDs .....	151
Tab. 108.	Command description - ChangeKey .....	130	Tab. 151.	Error code description - GetFileIDs .....	151
Tab. 109.	Response description - ChangeKey .....	132	Tab. 152.	Command Description - GetISOFileIDs .....	152
Tab. 110.	Error code description - ChangeKey .....	132	Tab. 153.	Command description - GetISOFileIDs .....	152
Tab. 111.	Command Description - GetKeySettings .....	133	Tab. 154.	Response description - GetISOFileIDs .....	152
Tab. 112.	Command description - GetKeySettings .....	133	Tab. 155.	Error code description - GetISOFileIDs .....	153
Tab. 113.	Response description - GetKeySettings - [No Option byte provided] .....	134	Tab. 156.	Command Description - GetFileSettings .....	153
Tab. 114.	Response description - GetKeySettings - [Option = 0x00] CryptoRequestKey's meta-data .....	134	Tab. 157.	Command description - GetFileSettings .....	153
Tab. 115.	Response description - GetKeySettings - [Option = 0x01] ECCPrivateKey's meta-data .....	134	Tab. 158.	Response description - GetFileSettings - Targeting FileType.StandardData .....	154
Tab. 116.	Response description - GetKeySettings - [Option = 0x02] CARootKey's meta-data .....	135	Tab. 159.	Response description - GetFileSettings - Targeting FileType.Counter .....	155
Tab. 117.	Error code description - GetKeySettings .....	135	Tab. 160.	Error code description - GetFileSettings .....	155
Tab. 118.	Command Description - GetKeyVersion .....	136	Tab. 161.	Command Description - GetFileCounters .....	156
Tab. 119.	Command parameters description - GetKeyVersion .....	136	Tab. 162.	Command description - GetFileCounters .....	156
Tab. 120.	Response description - GetKeyVersion .....	136	Tab. 163.	Response description - - Targeting FileType.StandardData with SDM enabled. ...	156
Tab. 121.	Error code description - GetKeyVersion .....	136	Tab. 164.	Response description - - Targeting FileType.Counter. ....	156
Tab. 122.	ManageKeyPair .....	137	Tab. 165.	Error code description - GetFileCounters .....	157
Tab. 123.	Command Description - ManageKeyPair .....	137	Tab. 166.	Command summary - ChangeFileSettings .....	157
			Tab. 167.	Command description - ChangeFileSettings .....	157
			Tab. 168.	Response description - ChangeFileSettings ..	161
			Tab. 169.	Error code description - ChangeFileSettings .....	161

Tab. 170. Command summary - ReadData .....	163	Tab. 206. CryptoRequest ECC_DH - ECC DH Single-	
Tab. 171. Command parameters description -		step Operation .....	175
ReadData .....	163	Tab. 207. CryptoRequest ECC_DH - ECC DH Two-	
Tab. 172. Response description - ReadData .....	164	step Step 1 .....	176
Tab. 173. Error code description - ReadData .....	164	Tab. 208. CryptoRequest ECC_DH - ECC DH Two-	
Tab. 174. Command summary - WriteData .....	165	step Step 2 .....	176
Tab. 175. Command parameters description -		Tab. 209. Response description - ECC DH Operation ..	176
WriteData .....	165	Tab. 210. Error Code Description - ECC DH	
Tab. 176. Response description - WriteData .....	165	Operation .....	176
Tab. 177. Error code description - WriteData .....	165	Tab. 211. Crypto API AES Key Selection .....	177
Tab. 178. IncrementCounterFile .....	166	Tab. 212. Crypto API AES Key Selection - AES Enc/	
Tab. 179. Command Description -		Dec Init Operation .....	177
IncrementCounterFile .....	166	Tab. 213. Crypto API AES Key Selection - AES Enc/	
Tab. 180. Response description -		Dec Update Operation .....	177
IncrementCounterFile .....	167	Tab. 214. Crypto API AES Key Selection - AES Enc/	
Tab. 181. Error code description -		Dec Finalize Operation .....	178
IncrementCounterFile .....	167	Tab. 215. Crypto API AES Key Selection - Format	
Tab. 182. Command Description - CryptoRequest .....	168	of crypto API AES Enc/Dec multi-part	
Tab. 183. Error Code Description - CryptoRequest .....	169	operation response data .....	178
Tab. 184. CryptoRequest SHA - SHA Init Operation .....	169	Tab. 216. Crypto API AES Key Selection - AES Enc/	
Tab. 185. CryptoRequest SHA - SHA Update		Dec One-Shot Operation .....	178
Operation .....	170	Tab. 217. Crypto API AES Key Selection - Format	
Tab. 186. CryptoRequest SHA - SHA Finalize		of crypto API AES Enc/Dec One-shot	
Operation .....	170	operation response data .....	179
Tab. 187. CryptoRequest SHA - SHA One-Shot		Tab. 218. Error Code Description - AES Operation .....	179
Operation .....	170	Tab. 219. CryptoRequest AES CMAC - AES CMAC	
Tab. 188. Response description - SHA Operation .....	170	Sign Init Operation .....	179
Tab. 189. CryptoRequest RNG - RNG Operation .....	171	Tab. 220. CryptoRequest AES CMAC - AES CMAC	
Tab. 190. Response description - RNG Operation .....	171	Sign Update Operation .....	179
Tab. 191. Error Code Description - RNG Operation .....	171	Tab. 221. CryptoRequest AES CMAC - AES CMAC	
Tab. 192. CryptoRequest ECC_Sign - ECC Sign Init		Sign Finalize Operation .....	180
Operation .....	171	Tab. 222. CryptoRequest AES CMAC - AES CMAC	
Tab. 193. CryptoRequest ECC_Sign - ECC Sign		Sign One-shot Operation .....	180
Update Operation .....	171	Tab. 223. CryptoRequest AES CMAC - Format of	
Tab. 194. CryptoRequest ECC_Sign - ECC Sign		crypto API AES CMAC Sign response data ..	180
Finalize Operation .....	172	Tab. 224. CryptoRequest AES CMAC - AES CMAC	
Tab. 195. CryptoRequest ECC_Sign - ECC Sign		Verify Init Operation .....	180
One-Shot Operation .....	172	Tab. 225. CryptoRequest AES CMAC - AES CMAC	
Tab. 196. CryptoRequest ECC_Sign - ECC Sign		Verify Update Operation .....	181
One-Shot Pre-computed Hash Operation .....	172	Tab. 226. CryptoRequest AES CMAC - AES CMAC	
Tab. 197. Response description - ECC Sign		Verify Finalize Operation .....	181
Operation .....	173	Tab. 227. CryptoRequest AES CMAC - AES CMAC	
Tab. 198. Error Code Description - ECC Sign		Verify One-shot Operation .....	181
Operation .....	173	Tab. 228. CryptoRequest AES CMAC - Format of	
Tab. 199. CryptoRequest ECC_Verify - ECC Sign Init		crypto API AES CMAC Verify response	
Operation .....	173	data .....	182
Tab. 200. CryptoRequest ECC_Verify - ECC Verify		Tab. 229. Error Code Description - AES Operation .....	182
Update Operation .....	173	Tab. 230. CryptoRequest AES AEAD - AES AEAD	
Tab. 201. CryptoRequest ECC_Verify - ECC Verify		Initialize Operation .....	182
Finalize Operation .....	174	Tab. 231. CryptoRequest AES AEAD - Format of	
Tab. 202. CryptoRequest ECC_Verify - ECC Verify		crypto API AES AEAD Initialize operation	
One-Shot Operation .....	174	response data .....	183
Tab. 203. CryptoRequest ECC_Verify - ECC Verify		Tab. 232. CryptoRequest AES AEAD - AES AEAD	
One-Shot Pre-computed Hash Operation .....	174	Update Operation .....	183
Tab. 204. Response description - ECC Verify		Tab. 233. CryptoRequest AES AEAD - Format of	
Operation .....	175	crypto API AES AEAD Update operation	
Tab. 205. Error Code Description - ECC Verify		response data .....	183
Operation .....	175	Tab. 234. CryptoRequest AES AEAD - AES AEAD	
		Finalize Operation .....	184

Tab. 235. CryptoRequest AES AEAD - Format of crypto API AES AEAD finalize operation response data .....	184	Tab. 255. Response description - ManageGPIO [else] .	192
Tab. 236. CryptoRequest AES AEAD - AES AEAD One-Shot Operation .....	184	Tab. 256. Error code description - ManageGPIO .....	192
Tab. 237. CryptoRequest AES AEAD - Format of crypto API AES AEAD One-shot operation response data .....	185	Tab. 257. ReadGPIO .....	193
Tab. 238. Error Code Description - AES Operation .....	185	Tab. 258. Command Description - ReadGPIO .....	193
Tab. 239. CryptoRequest - Write Internal Buffer Operation .....	186	Tab. 259. Response description - ReadGPIO .....	193
Tab. 240. Response description - Write Internal Buffer .....	186	Tab. 260. Error code description - ReadGPIO .....	194
Tab. 241. CryptoRequest HMAC - HMAC Operation .....	186	Tab. 261. Command summary - ISOSelectFile .....	195
Tab. 242. Response description - HMAC Verify Operation .....	187	Tab. 262. Command description - ISOSelectFile .....	195
Tab. 243. Response description - HMAC Sign Operation .....	187	Tab. 263. Response description - ISOSelectFile .....	196
Tab. 244. Error Code Description - HMAC Operation .....	187	Tab. 264. Error code description - ISOSelectFile .....	196
Tab. 245. CryptoRequest HKDF - HKDF Extract and Expand Operation .....	188	Tab. 265. Command summary - ISOReadBinary .....	197
Tab. 246. CryptoRequest HKDF - HKDF Expand Operation .....	188	Tab. 266. Command description - ISOReadBinary .....	197
Tab. 247. Response description - HKDF Operation .....	189	Tab. 267. Response description - ISOReadBinary .....	198
Tab. 248. Error Code Description - HKDF Operation .....	189	Tab. 268. Error code description - ISOReadBinary .....	198
Tab. 249. CryptoRequest Echo - Echo Operation .....	189	Tab. 269. Command summary - ISOUUpdateBinary .....	199
Tab. 250. Response description - Echo Operation .....	189	Tab. 270. Command description - ISOUUpdateBinary .....	199
Tab. 251. ManageGPIO .....	190	Tab. 271. Response description - ISOUUpdateBinary .....	200
Tab. 252. Command Description - ManageGPIO .....	190	Tab. 272. Error code description - ISOUUpdateBinary .....	200
Tab. 253. Response description - ManageGPIO [if GPIOXMode is output AND Operation[b7] == '1' AND issued over NFC] .....	192	Tab. 273. Limiting values .....	201
Tab. 254. Response description - ManageGPIO [if GPIOXMode is output AND Operation[b1] == '1' AND issued over NFC] .....	192	Tab. 274. Recommended operating conditions .....	202
		Tab. 275. Electrical DC characteristics of GPIO1/2 .....	203
		Tab. 276. Electrical DC characteristics of I2C .....	204
		Tab. 277. Electrical characteristics of IC supply voltage VCC .....	205
		Tab. 278. Authentication application timing .....	205
		Tab. 279. Nonvolatile memory timing characteristics .....	205
		Tab. 280. Nonvolatile memory data retention and endurance .....	205
		Tab. 281. Electrical AC characteristics of SDA, SCL .....	206
		Tab. 282. Electrical AC characteristics of LA, LB .....	206
		Tab. 283. Abbreviations .....	212
		Tab. 284. Revision history .....	218

## Figures

Fig. 1.	NTAG X DNA solution block diagram	3	Fig. 30.	ProcessSM command protocol	116
Fig. 2.	NTAG X DNA as an NFC tag	3	Fig. 31.	Protocol ProcessSM_Apply	117
Fig. 3.	NTAG X DNA for the consumable authentication	3	Fig. 32.	Protocol ProcessSM_Remove	118
Fig. 4.	NTAG X DNA for consumable authentication with NFC	4	Fig. 33.	FreeMem command protocol	120
Fig. 5.	NTAG X DNA for smart diagnostics	4	Fig. 34.	SetConfiguration command protocol	121
Fig. 6.	Battery-powered smart sensor	5	Fig. 35.	GetConfiguration command protocol	123
Fig. 7.	NFC-powered smart sensor	5	Fig. 36.	ActivateConfiguration command protocol	125
Fig. 8.	NTAG X DNA solution block diagram	5	Fig. 37.	GetVersion command protocol	126
Fig. 9.	Block diagram	7	Fig. 38.	GetCardUID command protocol	129
Fig. 10.	ISO/IEC 7816-4 command response pair	13	Fig. 39.	ChangeKey command protocol	130
Fig. 11.	Authentication State Diagram	16	Fig. 40.	GetKeySettings command protocol	133
Fig. 12.	Session key generation for Secure Messaging	28	Fig. 41.	GetKeyVersion command protocol	136
Fig. 13.	Plain Communication Mode	32	Fig. 42.	ManageKeyPair command protocol	137
Fig. 14.	Secure Messaging: MAC Communication mode	33	Fig. 43.	ManageCARootKey command protocol	140
Fig. 15.	Secure Messaging: CommMode.Full	34	Fig. 44.	ManageCertRepo command protocol	142
Fig. 16.	Secure Dynamic Messaging for Reading example	43	Fig. 45.	ReadCertRepo command protocol	145
Fig. 17.	Access conditions example	45	Fig. 46.	CreateStdDataFile command protocol	147
Fig. 18.	Conceptual View of Host Verification Public Keys	73	Fig. 47.	CreateCounterFile command protocol	149
Fig. 19.	Conceptual View of a Certificate Repository	74	Fig. 48.	GetFileIDs command protocol	150
Fig. 20.	Certificate Chain Example	75	Fig. 49.	GetISOFileIDs command protocol	152
Fig. 21.	Crypto API Transient Buffer Format	88	Fig. 50.	GetFileSettings command protocol	153
Fig. 22.	Crypto API Static Buffer Format	88	Fig. 51.	GetFileCounters command protocol	156
Fig. 23.	NFC Pause Example	92	Fig. 52.	ChangeFileSettings command protocol	157
Fig. 24.	NFC Pause Example with ISOReadBinary	93	Fig. 53.	ReadData command protocol	163
Fig. 25.	Tag Tamper illustration	97	Fig. 54.	WriteData command protocol	165
Fig. 26.	ISOGeneralAuthenticate command protocol	108	Fig. 55.	IncrementCounterFile command protocol	166
Fig. 27.	ISOInternalAuthenticate command protocol	109	Fig. 56.	CryptoRequest command protocol	168
Fig. 28.	AuthenticateEV2First command protocol	111	Fig. 57.	ManageGPIO command protocol	190
Fig. 29.	AuthenticateEV2NonFirst command protocol	114	Fig. 58.	ReadGPIO command protocol	193
			Fig. 59.	ISOSelectFile command protocol	195
			Fig. 60.	ISOReadBinary command protocol	197
			Fig. 61.	ISOUUpdateBinary command protocol	199
			Fig. 62.	Input characteristics of GPIO1/2	204
			Fig. 63.	Package outline WLCSP (Top view)	208
			Fig. 64.	Package outline WLCSP (Bottom view)	209
			Fig. 65.	Package outline HVQFN	210
			Fig. 66.	Pin description HVQFN	211

Contents

<b>1</b>	<b>General description</b>	<b>1</b>	6.4.6.3	MAC Calculation	31
<b>2</b>	<b>Features and use cases</b>	<b>2</b>	6.4.6.4	Encryption	31
2.1	Use cases	2	6.4.6.5	Session Key Generation	31
2.2	Key features	2	6.4.6.6	Communication Modes	32
2.3	Configuration	3	6.4.6.7	Plain Communication Mode	32
2.4	Configuration as NFC tag	3	6.4.6.8	MAC Communication Mode	32
2.5	Configuration as authenticator	3	6.4.6.9	Full Communication Mode	33
2.6	Configuration as crypto accelerator and diagnostics	4	6.4.7	Controller Session Key Usage	34
2.7	Configuration for smart sensor	5	6.4.7.1	ProcessSM	34
2.8	Configuration to secure IoT applications	5	6.4.7.2	ProcessSM_Apply	35
<b>3</b>	<b>Ordering information</b>	<b>6</b>	6.4.7.3	ProcessSM_Remove	35
<b>4</b>	<b>Block diagram</b>	<b>7</b>	6.4.8	Secure Dynamic Messaging	35
<b>5</b>	<b>Pin description</b>	<b>8</b>	6.4.8.1	SDM Read Counter	36
<b>6</b>	<b>Functional description</b>	<b>9</b>	6.4.8.2	SDM Read Counter Limit	37
6.1	NFC support	9	6.4.8.3	PICCCData	37
6.1.1	ISO/IEC 14443 parameter values	9	6.4.8.4	Encryption of PICCCData	38
6.1.2	Setting of higher communication speed	10	6.4.8.5	GPIOStatus	39
6.1.3	Half-duplex block transmission protocol	10	6.4.8.6	SDMENCFileData	39
6.1.4	Silent mode	10	6.4.8.7	Encryption of SDMENCFileData	40
6.2	I2C support	10	6.4.8.8	SDMMAC	40
6.2.1	I2C parameter values	11	6.4.8.9	MAC Calculation	41
6.2.1.1	Target address	11	6.4.8.10	SDMSIG	41
6.2.1.2	Communication interface parameters	11	6.4.8.11	Signature Calculation	42
6.2.2	I2C Application Remarks	11	6.4.8.12	SDM Session Key Generation	42
6.2.2.1	Power Management	11	6.4.8.13	Output Mapping Examples	43
6.2.2.2	Write after Write behavior	12	6.5	Access Rights Management	43
6.2.2.3	Waiting Time Extension behavior	12	6.5.1	Access conditions	43
6.3	Command format and chaining	12	6.5.2	CARootKey access rights	45
6.3.1	Native command format	12	6.5.3	Certificate access rights	46
6.3.2	ISO/IEC7816-4 communication frame	13	6.6	Card Memory and Configuration Management	48
6.3.3	Command chaining	13	6.6.1	Card UID	48
6.4	Authentication and Secure Messaging	15	6.6.1.1	Random ID	48
6.4.1	Authentication overview	15	6.6.1.2	Command GetCardUID	48
6.4.2	SIGMA-I authentication with ISOGeneralAuthenticate	17	6.6.2	Card Version	48
6.4.2.1	Session keys	17	6.6.2.1	Command GetVersion	50
6.4.2.2	Message types	17	6.6.3	Card configuration	50
6.4.2.3	Protocol exchange – Host as initiator	19	6.6.3.1	Deferred Configuration Options	50
6.4.2.4	Protocol exchange – Host as responder	20	6.6.3.2	Command SetConfiguration	51
6.4.2.5	SIGMA-I session key generation	21	6.6.3.3	Command GetConfiguration	65
6.4.2.6	NTAG X DNA Signature generation	22	6.6.3.4	Memory management	65
6.4.2.7	SIGMA-I: Verification of the host	23	6.7	Symmetric Key Management	65
6.4.3	ECC-based card-unilateral authentication	24	6.7.1	Key Types	65
6.4.3.1	Data structures and notations	24	6.7.2	Key Versioning	66
6.4.3.2	Cryptographic primitives	24	6.7.3	Symmetric Keys	66
6.4.3.3	ISOInternalAuthenticate	24	6.7.3.1	AppMasterKey	66
6.4.3.4	Authentication overview	25	6.7.3.2	AppKey	66
6.4.4	AES-based Symmetric Authentication	26	6.7.3.3	SDMMetaReadKey	67
6.4.4.1	Command AuthenticateEV2First	26	6.7.3.4	SDMFileReadKey	67
6.4.4.2	Command AuthenticateEV2NonFirst	27	6.7.3.5	AppPrivacyKey	67
6.4.4.3	Session Key Generation	28	6.7.3.6	CryptoRequestKey	67
6.4.5	AuthenticationCounter and Limit	29	6.7.4	Key Management Commands	67
6.4.6	EV2/AES secure messaging	30	6.7.4.1	Command ChangeKey	68
6.4.6.1	Transaction Identifier	30	6.7.4.2	Command GetKeySettings	69
6.4.6.2	Command Counter	30	6.7.4.3	Command GetKeyVersion	69
			6.8	Asymmetric Key Management	69

6.8.1	ECCPrivateKey Management	70	6.15.2	Tag Tamper Measurements	97
6.8.1.1	Command ManageKeyPair	70	6.15.3	Tag Tamper status retrieval	98
6.8.1.2	ECCPrivateKey Key Usage Limit	70	6.15.3.1	Mirroring in the NDEF message	98
6.8.1.3	ECCPrivateKey Information Retrieval	71	6.15.3.2	ReadGPIO	98
6.8.2	CARootKey Management	71	6.16	Timer Support	98
6.8.2.1	Command ManageCARootKey	71	6.16.1	Authority Watchdog Timers	98
6.8.2.2	CARootKey Information Retrieval	72	6.16.2	Halt Watchdog Timer	98
6.8.3	PICC/MF level	72	6.17	ISO/IEC 7816-4 Support	99
6.8.3.1	ECCPrivateKey entries	72	6.17.1	Standard ISO/IEC 7816-4 commands	99
6.8.4	Application/DF level	72	6.17.1.1	Byte order	99
6.8.4.1	ECCPrivateKey entries	72	6.17.1.2	Security concepts of standard ISO/IEC 7816-4 commands	99
6.8.4.2	CARootKey entries	72	6.17.1.3	Error Handling	100
6.8.5	Memory Consumption	72	6.17.1.4	ISOSelectFile	100
6.8.6	Certificate Cache	72	6.17.1.5	ISOReadBinary	101
6.9	Certificate Management	73	6.17.1.6	ISOUpdateBinary	101
6.9.1	ECC Certificate Repository Management	73	6.18	Trust Provisioning	102
6.9.1.1	Create Certificate Repository	74	6.18.1	Originality Check Key Pair and Certificate	102
6.9.1.2	Load Public Key Certificate Chain	74	6.18.1.1	Originality Key Pair	102
6.9.1.3	Certificate Mapping Table	75	6.18.1.2	Originality Certificate	102
6.9.1.4	Activate Certificate Repository	76	6.18.1.3	Card-unilateral authentication	103
6.9.2	Read Certificate Repository	77	6.18.2	Application Key Pair and Certificate	103
6.10	Application Management	77	6.18.2.1	Application Key Pair	103
6.10.1	Application Selection	77	6.18.2.2	Application Certificate	103
6.10.2	Application Definition	77	6.18.3	Commercial customization options	104
6.11	File Management	77	6.19	Security	104
6.11.1	File Types	77	6.19.1	Introduction	104
6.11.1.1	FileType.StandardData	77	6.19.2	Reset	105
6.11.1.2	FileType.Counter	78	6.19.3	Sensor Architecture	105
6.11.2	File Access Rights Management	78	6.19.4	Scalable Security	105
6.11.2.1	Secure Dynamic Messaging Related Access Rights	79	<b>7</b>	<b>Command set</b>	<b>106</b>
6.11.2.2	Access right association with commands	80	7.1	Introduction	106
6.11.2.3	Command ChangeFileSettings	81	7.2	Supported commands and APDUs	106
6.11.3	File Information Retrieval	82	7.3	Authentication and Secure Messaging	108
6.11.3.1	Command GetFileSettings	82	7.3.1	ISOGeneralAuthenticate	108
6.11.3.2	Command GetFileCounters	82	7.3.2	ISOInternalAuthenticate	109
6.11.3.3	Command GetFileIDs	83	7.3.3	AuthenticateEV2First	111
6.11.3.4	Command GetISOFileIDs	83	7.3.4	AuthenticateEV2NonFirst	114
6.11.4	File Creation	84	7.3.5	ProcessSM	116
6.11.4.1	Command CreateStdDataFile	84	7.3.6	ProcessSM_Apply	117
6.11.4.2	Command CreateCounterFile	84	7.3.7	ProcessSM_Remove	118
6.11.5	Memory Consumption	84	7.4	Memory and Configuration Management	120
6.11.6	File Definition	85	7.4.1	FreeMem	120
6.12	Data Management	86	7.4.2	SetConfiguration	121
6.12.1	Standard Data Files	86	7.4.3	GetConfiguration	123
6.12.1.1	Command ReadData	86	7.4.4	ActivateConfiguration	125
6.12.1.2	Command WriteData	87	7.4.5	GetVersion	126
6.12.2	Counter Files	87	7.4.6	GetCardUID	129
6.12.2.1	Command IncrementCounterFile	87	7.5	Symmetric Key management	130
6.13	Crypto API	88	7.5.1	ChangeKey	130
6.14	GPIO Management	90	7.5.2	GetKeySettings	133
6.14.1	NFC Pause feature	90	7.5.3	GetKeyVersion	136
6.14.2	Command ManageGPIO	93	7.6	Asymmetric Key Management	137
6.14.3	Command ReadGPIO	94	7.6.1	ManageKeyPair	137
6.14.4	Mirroring in the NDEF message	96	7.6.2	ManageCARootKey	140
6.14.5	Authentication notification	96	7.6.3	GetKeySettings	142
6.14.6	NFC field notification	96	7.7	Certificate Management	142
6.15	Tag Tamper Protection	96	7.7.1	ManageCertRepo	142
6.15.1	Enabling the Tag Tamper feature	97	7.7.2	ReadCertRepo	145

7.8	File Management .....	147
7.8.1	CreateStdDataFile .....	147
7.8.2	CreateCounterFile .....	149
7.8.3	GetFileIDs .....	150
7.8.4	GetISOFileIDs .....	152
7.8.5	GetFileSettings .....	153
7.8.6	GetFileCounters .....	156
7.8.7	ChangeFileSettings .....	157
7.9	Data Management .....	163
7.9.1	ReadData .....	163
7.9.2	WriteData .....	165
7.9.3	IncrementCounterFile .....	166
7.10	Crypto API .....	168
7.10.1	CryptoRequest SHA .....	169
7.10.2	CryptoRequest RNG .....	171
7.10.3	CryptoRequest ECC_Sign .....	171
7.10.4	CryptoRequest ECC_Verify .....	173
7.10.5	CryptoRequest ECC_DH .....	175
7.10.6	CryptoRequest AES .....	177
7.10.7	CryptoRequest AES CMAC .....	179
7.10.8	CryptoRequest AES AEAD .....	182
7.10.9	CryptoRequest Write Internal Buffer .....	186
7.10.10	CryptoRequest HMAC .....	186
7.10.11	CryptoRequest HKDF .....	188
7.10.12	CryptoRequest Echo .....	189
7.11	GPIO Management .....	190
7.11.1	ManageGPIO .....	190
7.11.2	ReadGPIO .....	193
7.12	ISO7816-4 Support .....	195
7.12.1	ISOSelectFile .....	195
7.12.2	ISOReadBinary .....	197
7.12.3	ISOUpdateBinary .....	199
<b>8</b>	<b>Limiting values .....</b>	<b>201</b>
<b>9</b>	<b>Recommended operating conditions .....</b>	<b>202</b>
<b>10</b>	<b>Characteristics .....</b>	<b>203</b>
10.1	DC characteristics .....	203
10.1.1	General-purpose I/O interface .....	203
10.1.2	I2C interface .....	204
10.1.3	Power Consumption .....	205
10.2	AC characteristics .....	205
10.3	I2C Bus Timings .....	207
10.4	EMC/EMI .....	207
<b>11</b>	<b>Package information .....</b>	<b>208</b>
11.1	WLCSP 16 .....	208
11.2	HVQFN 20 .....	210
11.3	Sawn wafer .....	211
<b>12</b>	<b>Abbreviations .....</b>	<b>212</b>
<b>13</b>	<b>References .....</b>	<b>215</b>
<b>14</b>	<b>Note about the source code in the document .....</b>	<b>217</b>
<b>15</b>	<b>Revision history .....</b>	<b>218</b>
	<b>Legal information .....</b>	<b>219</b>

Please be aware that important notices concerning this document and the product(s) described herein, have been included in section 'Legal information'.