



X-in-1 Modular Platform Concept

Redefining electrification integration:
faster, smarter, simpler

Table of contents

Introduction.....	3
X-in-1 modular platform concept offer.....	5
2-in-1 DC-DC + BMS (S32K39 MCU-based).....	7
2-in-1 DC-DC + inverter (S32K39 MCU-based)	8
X-in-1 functional safety documentation.....	9
Development platforms.....	10

Introduction

X-in-1: what & why?

The rapid advancement of electric vehicle technologies is driving greater integration in powertrain architectures. Conventional EV designs, which rely on discrete components such as the traction inverter, motor, gearbox, battery management system (BMS), on-board charger (OBC), and DC-DC converter, often increase system complexity, wiring, packaging constraints, weight, and reduce overall thermal and energy efficiency.

To overcome these limitations, the industry is moving toward X-in-1 system integration, consolidating multiple powertrain and energy-conversion functions into a single, optimized module. The next phase of integration enables multiple software applications to run on a single microcontroller, introducing challenges related to safe isolation and interference management. NXP's analog and digital S32K MCU portfolio is designed to address these requirements.

Integrating multiple electrification applications in one MCU without compromising safety and scalability

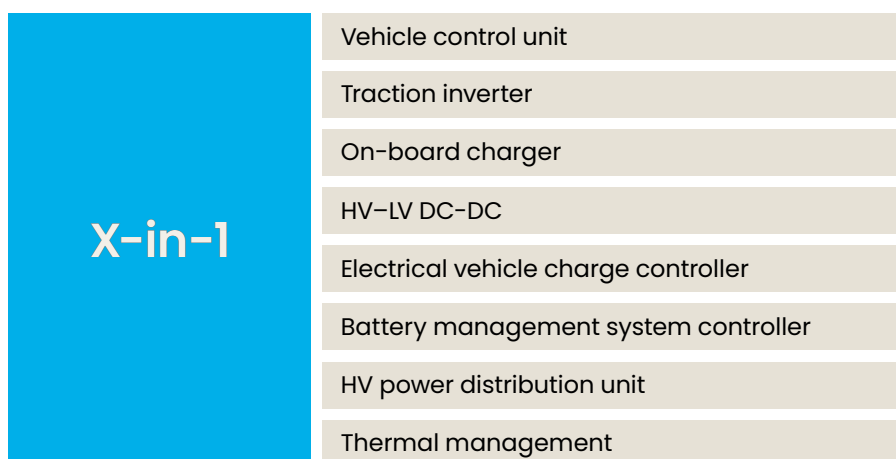

Figure 1: Typical electrification systems integrated into one



X-in-1 modular platform concept

The NXP X-in-1 modular platform provides a scalable hardware and software foundation for advanced electrification system integration. Designed to support a wide range of system configurations and NXP components, it enables rapid consolidation of multiple software applications onto a single control chip, simplifying X-in-1 designs for automakers and Tier-1 suppliers.

By reducing complexity, cost, and development time, the platform accelerates innovation and shortens time to market for next-generation electrification solutions. It also offers a flexible, low-voltage development environment that helps teams evaluate software integration, reference designs, and functional safety considerations—particularly software isolation—early in the design process.

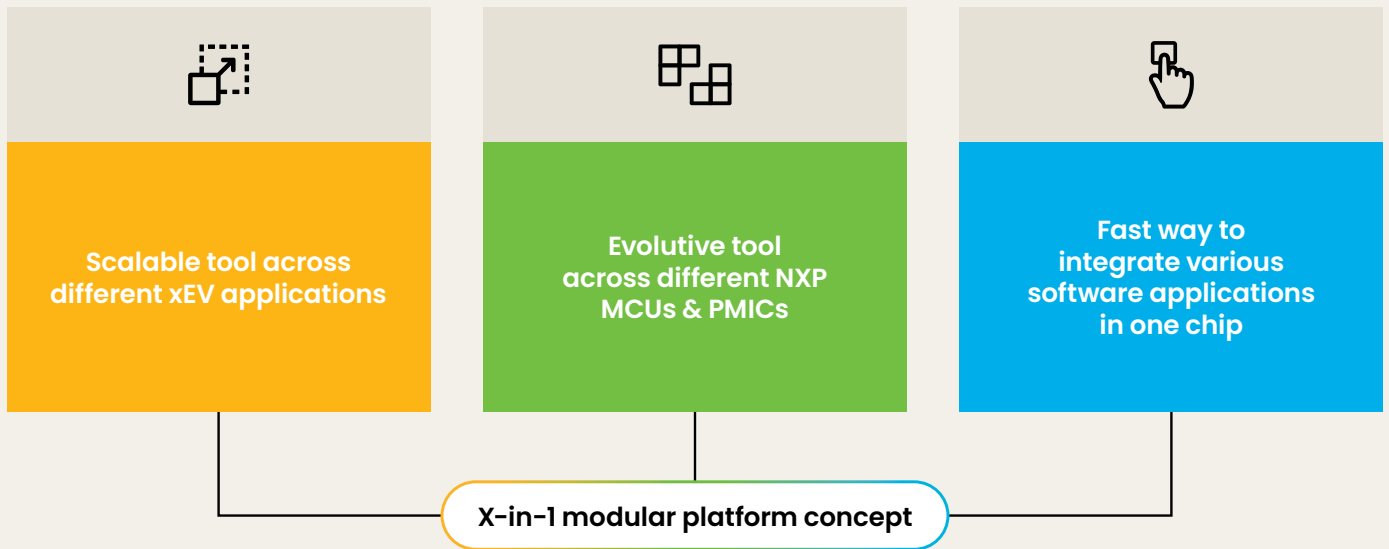

X-in-1 modular platform concept offer

The X-in-1 modular platform is structured around targeted use cases for e-Axle and battery systems, reflecting key industry integration trends. Each use case provides a complete set of hardware, software, tools, and documentation to support efficient multi-application software integration. Customers can evaluate system-level and safety-related interactions or develop custom applications on the platform. Following use-case definition and pre-validation, NXP supports the transition to high-voltage system validation through Functional Safety documentation and access to its partner ecosystem.

Hardware	Software	Extended documentation	Functional safety documentation	Ecosystem
<ul style="list-style-type: none"> • Control mother board with S32K EVB Kit • Analog application actuation board (Inverter, BMS, DC-DC..) 	<ul style="list-style-type: none"> • Production ready system real-time drivers (RTD) • FlexFoundation software responsible for orchestration between applications (light version for S32K39 MCU) • Application software: dedicated functions for each application running on specific cores/ tasks with their own operating system • FlexFoundation tool (S32K5 MCU) A GUI-based configuration tool designed to simplify the use of S32 devices for multi-application setups* 	<p>Full system documentation</p> <ul style="list-style-type: none"> • System application note: concept overview to simplify system understanding • Hardware and software function overview application note: covering inverter, DC-DC, BMS application from hardware and software standpoint • Hardware mother board overview application note • User manual by use case to ease and guide customer on proof of concept setup 	<p>Functional safety concepts</p> <ul style="list-style-type: none"> • 3-in-1 ASIL D EV traction inverter + ASIL B on-board charger + ASIL C DC-DC • 3-in-1 ASIL D battery management system + ASIL B on-board charger + ASIL C DC-DC* <p>X-in-1 integration safety concept application note</p> <ul style="list-style-type: none"> • Application note covering safe processing and isolation of multiple applications concept for S32K39 MCU • High-level functional safety concept + light TSC • Mixed integrity partitioning for X-in-1 (XRDC, MPU, IO & isolation for S32K396 example) 	<ul style="list-style-type: none"> • S32K partner ecosystem: debugger, simulation, AUTOSAR, safety and more • X-in-1 partner Once the X-in-1 use cases are frozen and multi-application software integration is pre-validated; the customer will move to prototype-A design in a high-voltage environment

Figure 2: X-in-1 modular platform concept complete offering

* Under development

X-in-1 modular platform concept offer schedule

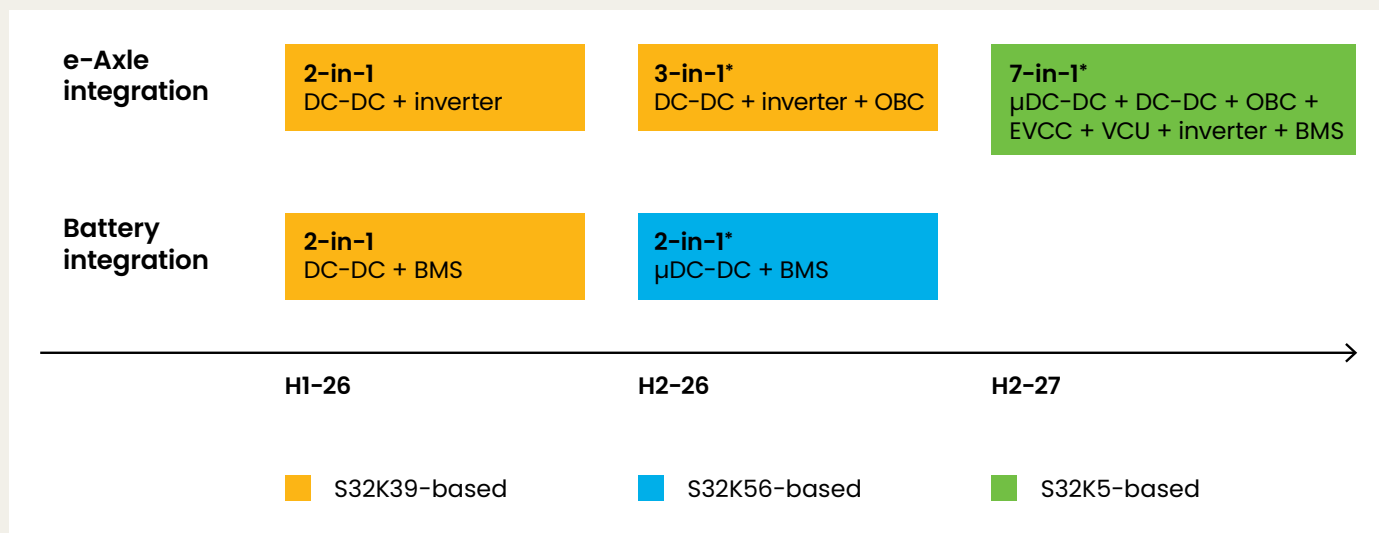

Figure 3: X-in-1 modular platform concept availability

* Under development

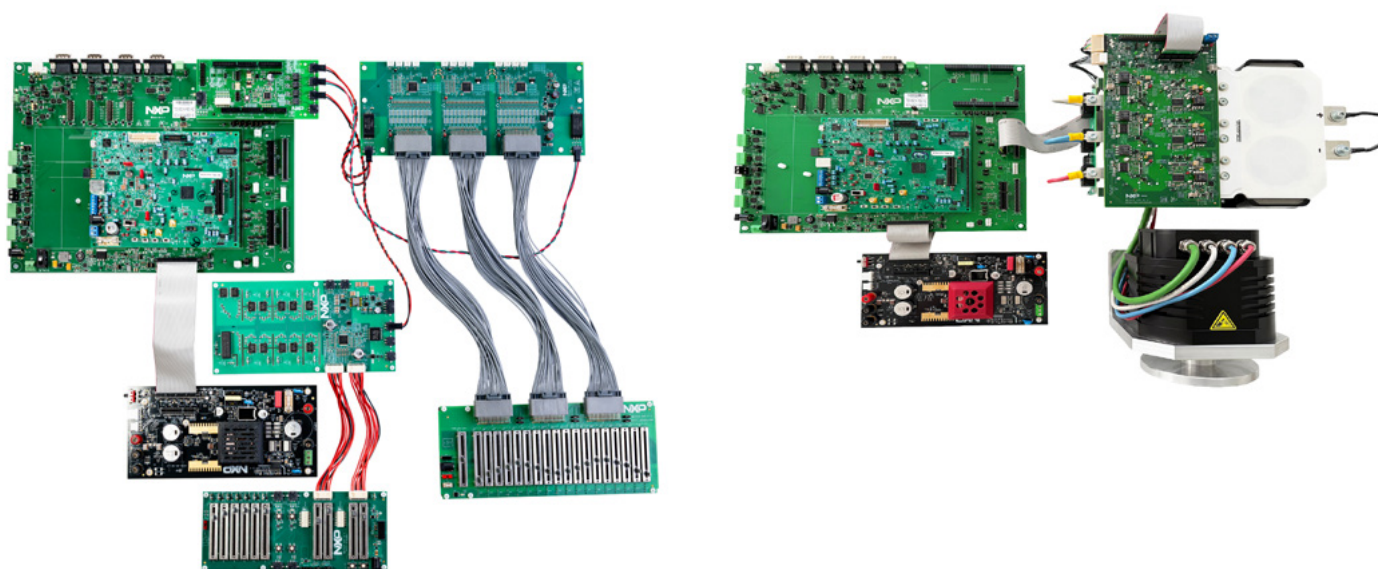

Figure 4: Hardware setup for 2-in-1 DC-DC + BMS and 2-in-1 DC-DC + inverter use cases

2-in-1 DC-DC + BMS (S32K39 MCU-based)

This use case integrates DC-DC & BMS function based on NXP S32K39 MCU. This reflects typical integration system around the battery.

High-level diagram

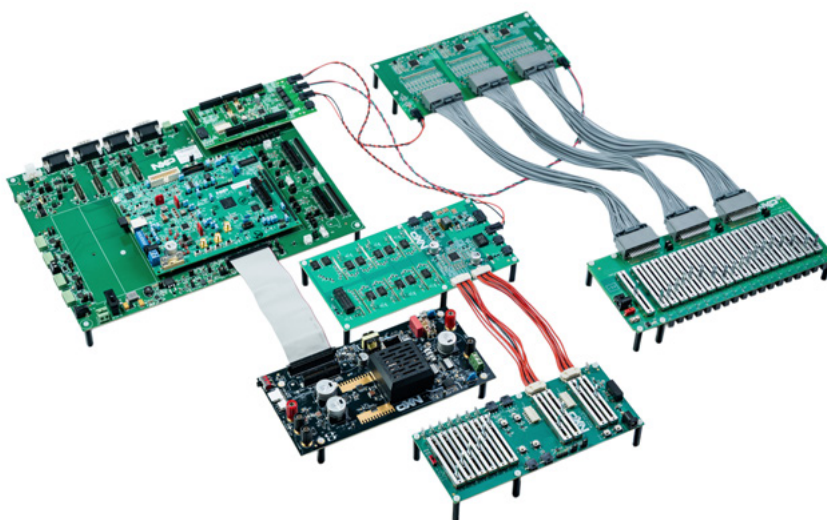
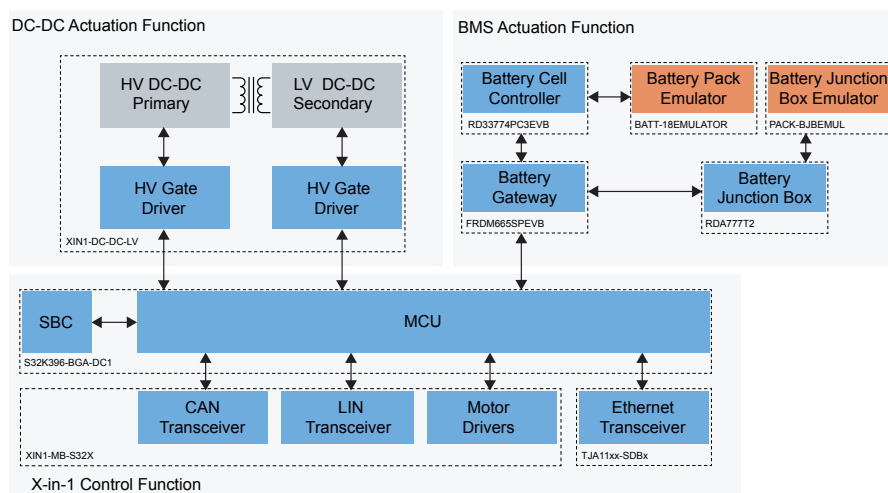

Figure 5: Hardware setup for 2-in-1 DC-DC + BMS use case

Features

- 100 W 48 V to 12 V DC-DC with GaN low-loss switches
- BMS: Battery Management System with battery junction box function
- System safety manager

Supported devices

Mother boards

- [S32K39](#): ASIL D microcontroller
- [FS26](#): Safety system basis chip (SBC) for ASIL D systems
- [HB2001](#): SPI programmable 10 A H-bridge
- [TJA146x](#): Signal Improvement CAN

BMS function

- Gateway: [MC33665](#) Gateway device
- Cell management unit: [MC33774](#) 18-ch ASIL D battery cell controller
- Battery junction box: [MC33777](#) battery junction box monitor

Supported software

Application demo software

- BMS application software: Battery State of Health (SoH) and State of Charge (SoC)
- DC-DC application software: Up to 300 kHz control loop

Orchestration software

- Ensures safety-critical logic running on master safety core which is isolated by XRDC from application logic running on application cores

2-in-1 DC-DC + inverter (S32K39 MCU-based)

This use case integrates DC-DC & traction inverter function based on NXP S32K39 MCU. This reflects typical integration system around the e-Axle.

High-level diagram

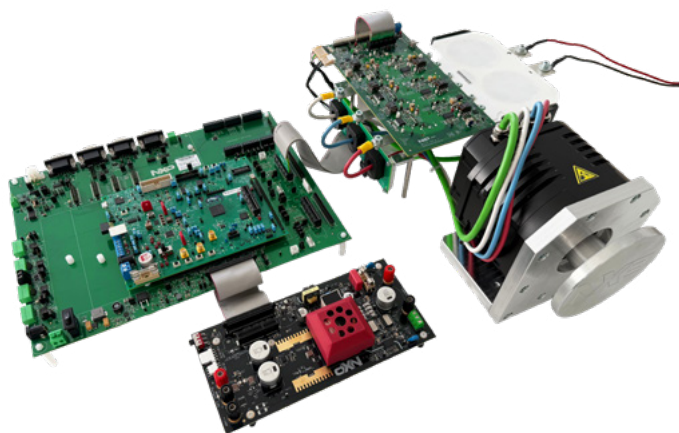
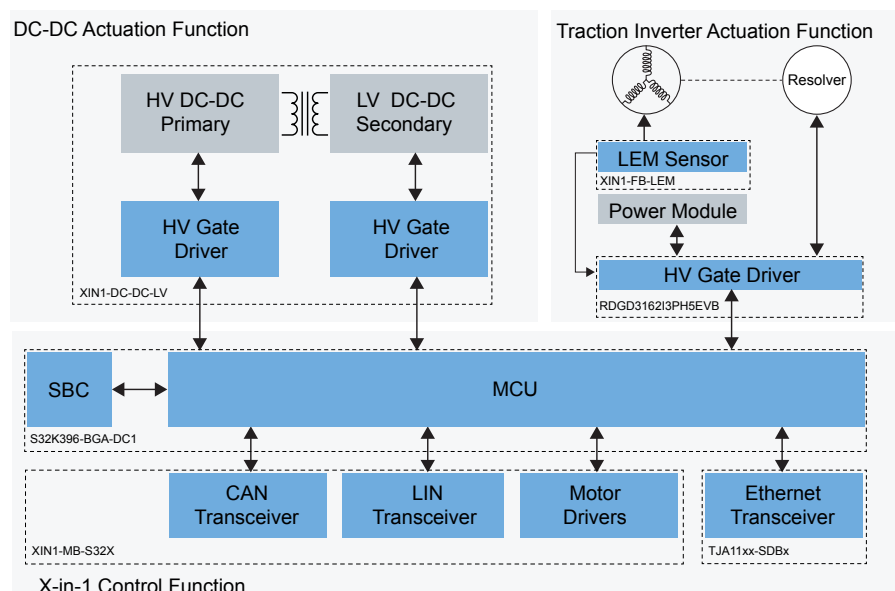

Figure 6: Hardware setup for 2-in-1 DC-DC + inverter use case

Features

- 100 W 48 V to 12 V DC-DC with GaN low-loss switches
- IGBT/SiC traction inverter
- System safety manager

Supported devices

Mother boards

- [S32K39](#): ASIL D microcontroller
- [FS26](#): Safety system basis chip (SBC) for ASIL D systems
- [HB2001](#): SPI programmable 10 A H-bridge
- [TJA146x](#): Signal Improvement CAN

Traction inverter function

- [GD3162](#): HV gate driver

Supported software

Application demo software

- Inverter application software: 15 kHz field-oriented control (FoC) example
- DC-DC application software: 200 kHz control loop

Orchestration software

- to ensure safety-critical logic running on master safety core which is isolated by XRDC from application logic running on application cores

X-in-1 functional safety documentation

The X-in-1 functional safety documentation from NXP simplifies complex system integration by addressing safe isolation and processing at the system level. Leveraging proven use cases, tight alignment with NXP's analog and digital portfolio, and dedicated safety expertise.

- **Reducing complexity:** Ensuring safe isolation & processing with NXP S32K MCU
- **Saving time:** Functional safety concept at system level based on dedicated use cases
- **Easy to use:** Direct correlation with NXP analog & digital portfolio
- **Safety consultancy:** Dedicated team to tailor functional safety concept according to customer needs

Functional safety concept process

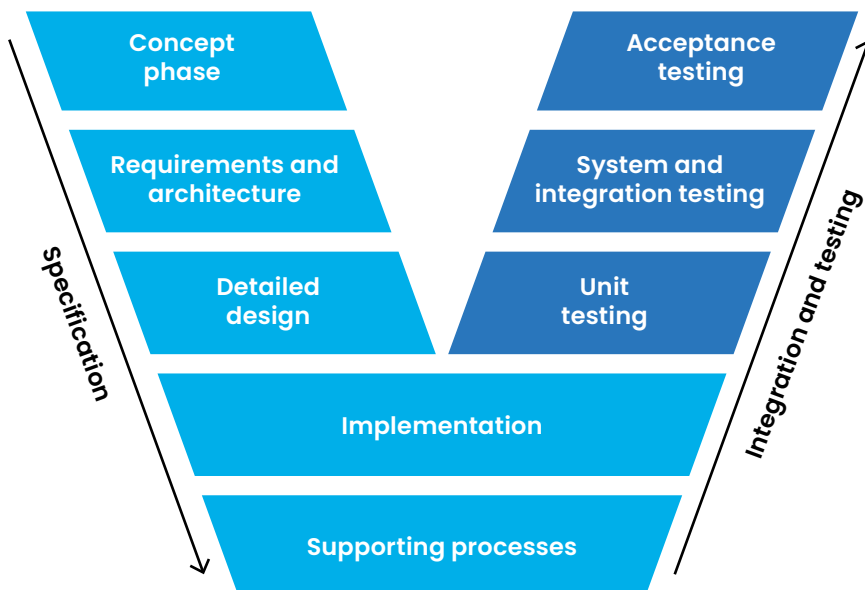

Functional safety concepts

- 3-in-1 ASIL D EV traction inverter
+ ASIL B on-board charger
+ ASIL C DC-DC
- 3-in-1 ASIL D battery management system
+ ASIL B on-board charger
+ ASIL C DC-DC
(under development)

Application note

X-in-1 integration safety concept application note

- Application note covering safe processing and isolation of multiple applications concepts for S32K39
- High-level functional safety concept + light TSC
- Mixed integrity partitioning for X-in-1 (XRDC, MPU, IO & isolation for S32K396 example)

Development platforms

Our development platforms, evaluation boards and tools are available to help accelerate your electrification designs.

nxp.com/X-IN-1-MODULAR-PLATFORM

Hardware		
	Description	Part number
S32K39 X-in-1 control mother board	Mother board for S32K39	XINI-MB-S32X
	S32K39 MCU EVB KIT	S32K396-BGA-DC1
Inverter application	Gate driver board	RDGD3162I3PH5EVB
	LEM sensor board	XINI-FB-LEM
	Cable between mother board & gate driver board recommended 6 inch PCIe	XINI-CABLE6
	Cable between mother board & gate driver board alternative 12 inch PCIe	XINI-CABLE12
	Power module: not provided – compatible with HybridPack	NA
DC-DC application	DC-DC board	XINI-DC-DC-LV
	Cable between mother board & DC-DC board: recommended 6 inch PCIe	XINI-CABLE6
BMS application	BMS TPL gateway board	FRDM665SPIEB
	BMS cell monitoring unit	RD33774PC3EVB
	Battery junction box board	RDA777T2
BMS emulator for test set up	18-cell battery pack emulator to supply MC33774 BCC EVB	BATT-18EMULATOR
	Battery junction box emulator	PACK-BJBEMUL

Software & GUI		Description
	S32K396 electrification X-in-1 DCDC & BMS	Production ready system RTD (S32K39, FS26, MC33775, MC33665, MC33777)
	and	FlexFoundation light software Orchestration software to ensure safety-critical logic running on Primary Safety Core which is isolated by XRDC from application logic running on application cores
	S32K396 electrification X-in-1 DCDC & inverter	Demo application software BMS (Battery SoH & SoC) & DC-DC (PI voltage control loop)
	Electrification X-in-1 GUI	GUI application to control required parameter, collect data and inject errors

Extended documentation		Description	
	System overview application note	AN14978	Concept overview to simplify system understanding by covering the device, hardware, software and related collateral
	User manual by use case	UM12522	User manual for 2-in-1 DC-DC + inverter use case (S32K39 based)
		UM12521	User manual for 2-in-1 DC-DC + BMS use case (S32K39 based)
	Hardware and software overview by function	Inverter hardware & software application note AN14965	Overview simplify application understanding by covering the device, hardware, software and related collateral
		DC-DC hardware & software application note AN14966	Overview simplify application understanding by covering the device, hardware, software and related collateral
		BMS hardware & software application note AN15020	Overview simplify application understanding by covering the device, hardware, software and related collateral
Hardware mother board overview	AN14977	S32K39 motherboard hardware overview	

Functional safety documentation		Description
	AN14911	X-in-1 integration safety concept application note
	AN14970	3-in-1 functional safety concept for ASIL D EV traction inverter + ASIL B OBC + ASIL C DC-DC

NXP product summary for X-in-1 applications

Device	Description
FS25	The FS25 system basis chip (SBC) is designed to support NXP's S32K5 devices by managing power distribution and system control
FS26	The FS26 is a family of automotive safety system basis chip (SBC) devices that offer multiple power supply options designed to support entry and mid-range safety microcontrollers like the S32K3 series
TJA1057	High-speed CAN transceiver with standby mode featuring superior EMC and ESD performance for automotive and industrial applications
TJA146x	CAN SIC Transceiver with Partial Networking, CAN FD Data Rates Up to 8 Mbits
TJA11xx	ASIL B Compliant Automotive Ethernet 1000BASE-T1 PHY Transceiver
TJA102x	Dual LIN 2.2 compliant SAEJ2602 transceiver that provides the interface between a LIN leader/follower protocol controller
S32K39-37-36	S32K3 is a scalable family of AEC-Q100 qualified 32-bit Arm Cortex®-M7F based MCUs targeted for ASIL D functional safety automotive and industrial applications
S32K5	S32K5 high performance automotive microcontrollers for ECU consolidation in zone control, domain control and electrification
GD3160	The GD3160 is an advanced single-channel high-voltage isolated gate driver with enhanced features for driving and protecting silicon carbide (SiC) MOSFETs or IGBTs and functional safety
GD3162	The GD3162 is an advanced, galvanically-isolated, single-channel gate driver designed to drive the latest SiC and IGBT modules for xEV traction inverters
HB200x	ASIL C and D H-bridge power IC with SPI configurability, designed for DC motor control applications
MC33665A	General Purpose BMS Communication TPL Transceiver and CAN FD Gateway
BMX6X02	Dual-channel battery management communication gateway and transport protocol link (TPL) for EIS synchronization
MC33774	18 Channel Li-Ion Battery Cell Controller IC ASIL D
BMA7x18	18 Channel Li-Ion Battery Cell Controller IC ASIL D and EIS capability
MC33777	Battery Junction Box controller IC for automotive applications, including HEVs, EVs, and industrial ESS systems
BMA8420	BMA8420 is a battery junction box controller IC with EIS capability designed for automotive applications

[nxp.com/x-in-1](https://www.nxp.com/x-in-1)

Driving Ethernet, NXP and the NXP logo are trademarks of NXP B.V. All other product or service names are the property of their respective owners. © 2026 NXP B.V.

Document Number: XIN_AUTOELECTBR REV 0

