

AN12826

BTS6201U evaluation board application note

Rev. 1.2 — 23 February 2021

Application note

Document information

Information	Content
Keywords	BGU6201U, 5G NR TX pre driver, Massive MIMO.
Abstract	This application note describes the design considerations/choices for the product evaluation board (EVB) and gives an overview of the typical performance as measured on the EVB. The BTS6201U is a wideband, high linearity, pre-driver amplifier for 5G massive MIMO infrastructure applications. To enable easy evaluation of the product, the EVB is supplied with all necessary connectors.



1 Front matter

Revision history		
Rev	Date	Description
1.0	20200710	Initial document
1.1	20200721	Small updates after review.
1.2	20210223	Updates at CQS gate.

2 Introduction

NXP semiconductors BTS6201U is a wideband high linear pre-driver amplifier for 5G, sub 6 GHz, massive MIMO infrastructure applications, with fast on-off switching to support TDD systems. The BTS6201U is designed to operate between 2.3 GHz and 4.2 GHz.

Being manufactured in NXP's high performance QUBiC RF Gen 8 SiGeC technology, the BTS6201U combines high gain, high linearity with process stability and ruggedness, which are the characteristics of the SiGeC technology.

This application note focuses on the BTS6201U evaluation board, the application diagram, board layout, bill of materials and control signals are described.

Refer to the data sheet for the detailed RF performance of the BTS6201U. The Customer Evaluation Kit (CEK) contains the following items:

- BTS6201U EVB
- DC supply cables

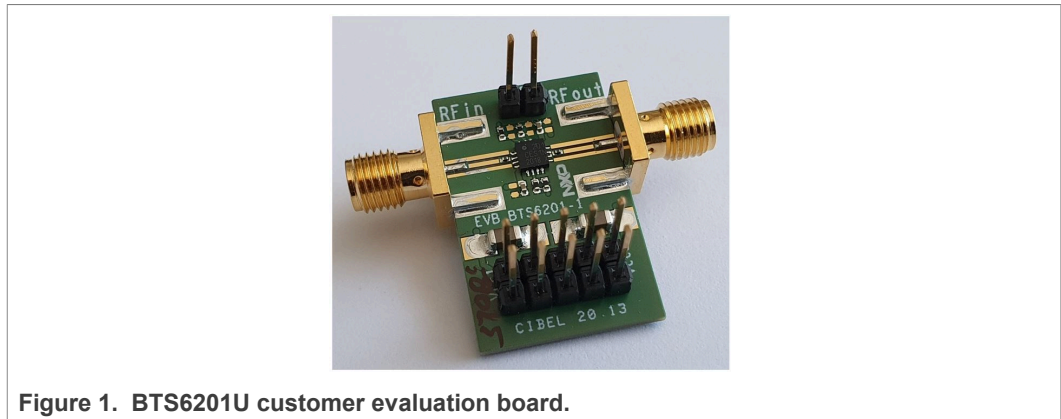

Figure 1. BTS6201U customer evaluation board.

2.1 Ordering information

Table 1. Ordering information

Description	Type	ordering 12NC
BTS6201UCustomer Evaluation Kit (CEK)	OM17076	9354 046 28598

3 Product description

The BTS6201U is a wideband, high linearity, pre-driver amplifier for 5G massive MIMO infrastructure applications, with fast on-off switching to support TDD systems. The amplifier is designed to operate between 2.3 GHz and 4.2 GHz. BTS6201U comes in the industry standard 3 mm × 3 mm × 0.85 mm 16 terminal plastic thin small outline package HVQFN16 (SOT758-1). The amplifier is ESD protected on all terminals.

The BTS6201U key features and benefits are listed below.

- High saturated output power $P_{o(sat)} = 27$ dBm
- High power-gain $G_p = 29$ dB
- High linearity performance ACLR = -46 dBc
- Unconditionally stable
- Programmable bias current (via external resistor)
- Fast switching to support TDD systems
- 5 V single supply, quiescent current 78 mA
- Small 16-terminal leadless package 3 mm × 3 mm × 0.85 mm
- ESD protection on all terminals
- Moisture sensitivity level 1

BTS6201U Pinout and Functional diagram

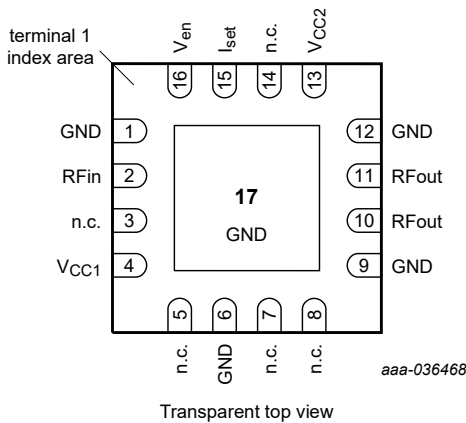

Figure 2. Pinout

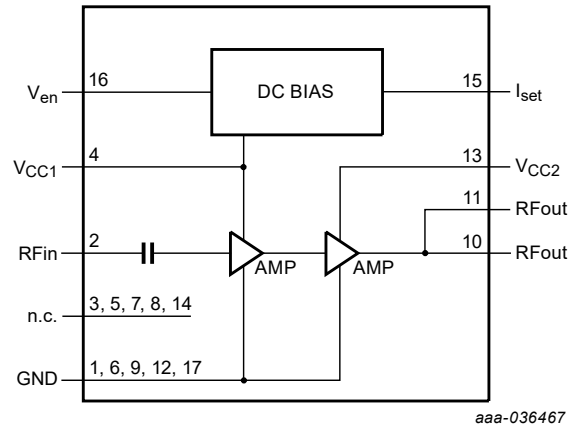

Figure 3. Functional diagram

4 Application board

The BTS6201U evaluation board simplifies the RF evaluation of the BTS6201U. The evaluation board enables testing the device RF performance, in an isolated environment, and requires no additional support circuitry. To de-embed applied RF connectors, and transmission lines up to the input and output DC blocking capacitors de-embedding data is available on request. Input and output track are symmetrical.

The BTS6201U evaluation board is fabricated on a 28 mm x 17 mm x 1 mm thick 3 layer PCB. The 0.3 mm top layer uses TU-862 for optimal RF performance. The board is fully assembled according to the schematic shown below. The board is supplied with two SMA connectors to connect input and output to the RF test equipment.

4.1 Application circuit

The application board circuit diagram that is implemented on the EVB is shown in [Figure 5](#).

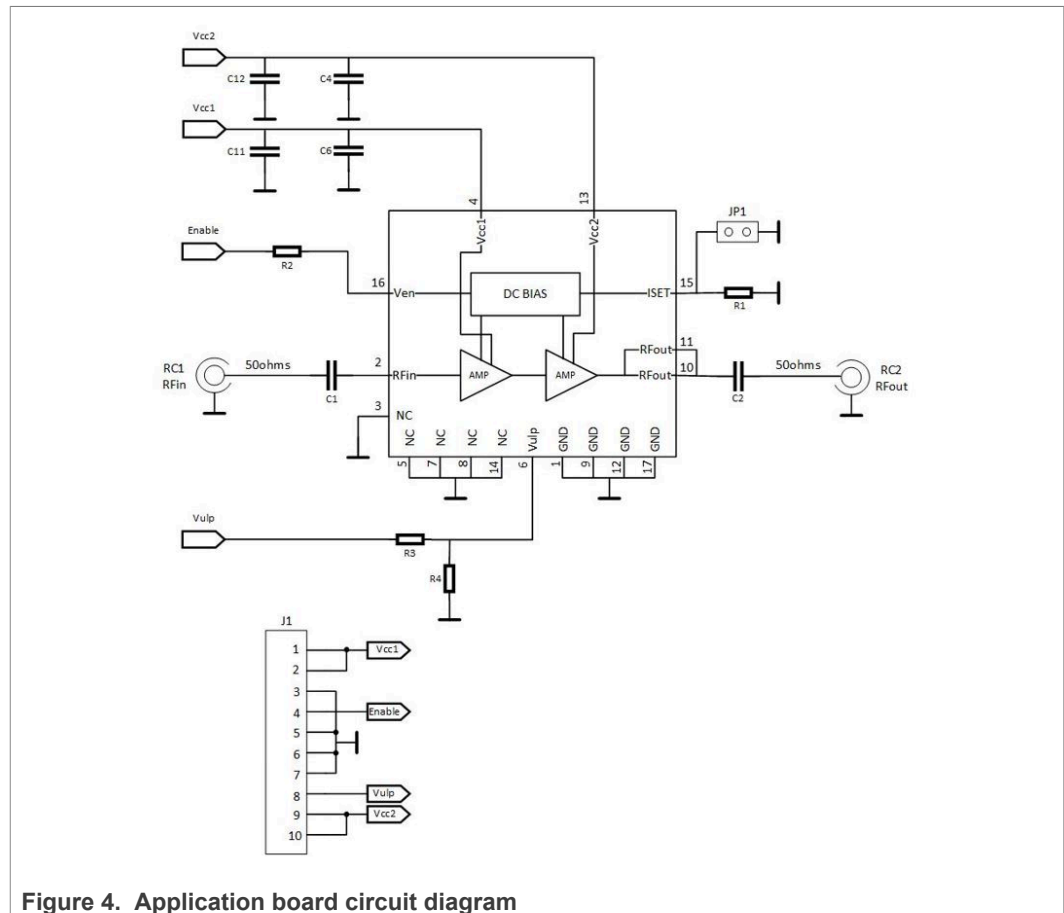

Figure 4. Application board circuit diagram

The RF input and output signals can be applied via SMA connector RC1 and RC2, capacitors C1 and C2 are DC-blocking capacitors.

The evaluation board is supplied with a 1.2 kΩ I_{set} resistor R1. Adding R1 results in a quiescent current of ~78 mA.

4.2 PCB Layout information and component selection

- A good PCB layout is an essential part of an RF circuit design. The evaluation board of the BTS6201U can serve as a guideline for laying out a board using the BTS6201U.
- The evaluation board uses micro strip coplanar ground structures for controlled impedance lines for the high frequency input and output.
- V_{cc1} and V_{cc2} are bypassed by C5 and C11 and C4 and C12 decoupling capacitors respectively. C5, C11 and C4, C12 decoupling capacitors respectively bypass V_{CC1} and V_{CC2} . C4 and C5 preferably should be located as close as possible < 1 mm to the device, to avoid AC leakage via the bias lines. For long bias lines, it may be necessary to add decoupling capacitors along the line further away from the device.
- In this report, as well as in the data sheet the value of C1 and C2 are stated as 18 pF. The values of C1 and C2 are critical for power on/off settling time. In case the value for those capacitors is increased significantly the switching speed is affected.
- Proper grounding of the GND pins is also essential for good RF performance. Either connect the GND pins directly to the ground plane or through vias, or do both, which is recommended. The layout and component placement of the BTS6201U evaluation board is given in [Figure 5](#)
- Resistor R2 in the Enable Line on EVB is chosen to be 0 Ω . For current limitations in the system application, it is recommended to use a R2 value of 2 k Ω .

4.2.1 Evaluation board layout

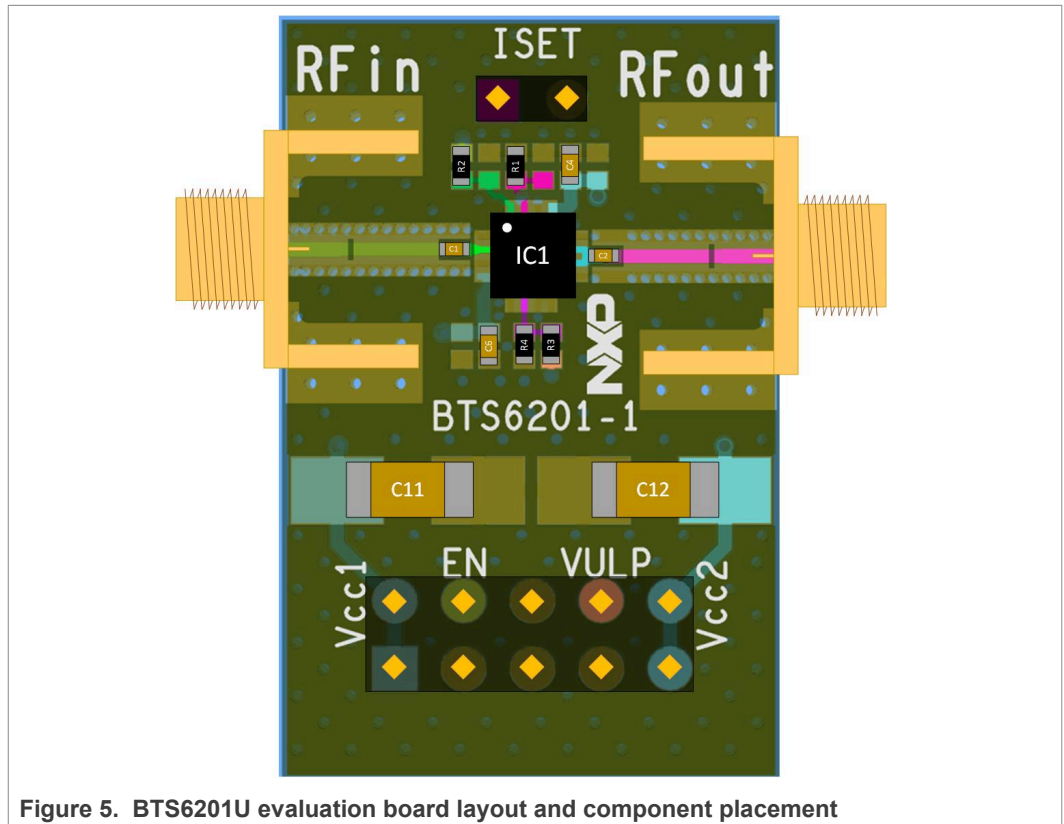

Figure 5. BTS6201U evaluation board layout and component placement

4.2.2 PCB stack and recommended footprint

The material stack-up used for the pre-driver circuit is a 0.3 mm TU-862 low RF loss layer, merged with a 0.7 mm FR4 layer. See Figure 6. The official drawing of the recommended footprint can be found via following link [SOT758-1.pdf](#). When micro strip coplanar PCB technology is used, it is recommended to use at least 12 ground-vias of 300 µm. These ground-vias are positioned in the ground plane under the device. This technique is also used on the EVBs as shown in Figure 7.

PCB stack and footprint information

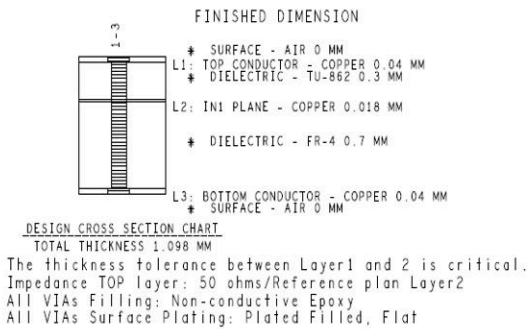

Figure 6. Cross section off the PCB layer stack

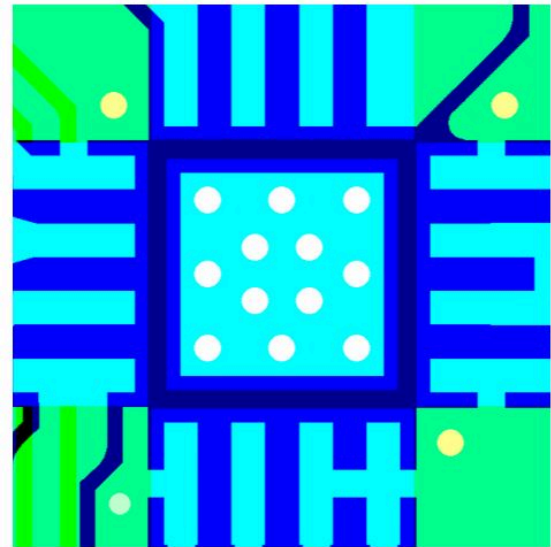

Figure 7. Recommended footprint

4.3 Bill of materials

Table 2. Evaluation board BOM

Gives the bill of materials as is used on the EVB

Designator	Description	Footprint	Value	Supplier Name/type	Comment/function
IC1	BTS6201U				
PCB	28x17x1mm				TU-862
C1, and C2	Capacitor	0201	18 pF	Various	DC block
C4, and C6	Capacitor	0402	10 nF	Various	RF decoupling
C11, and C12	Capacitor	1206	10 µF	Various	Optional
R1	Resistor	0402	1.2 kΩ	Various	Quiescent current setting
R2, R3, and R4	Resistor	0402	0 Ω	Various	Bridge
RC1, and RC2	SMA RF connector			Johnson, End launch SMA 142-0701-841	RF connections
JP1	Jumper			Molex, PCB header,	
J1	DC header			Molex, PCB header, straight, 2 row 5 way	DC connections

5 Evaluating the BTS6201U

All RF performance results given in the next chapters are referenced to the SMA connectors RC1 and RC2 on the evaluation board. In the data sheet characteristics, board connectors and PCB tracks are de-embedded up-to the product input and output DC blocking capacitors.

5.1 Typical results

For detailed performance of the BTS6201U, we refer to the device product data sheet.

Typical EVB performance

$V_{CC} = 5.0\text{ V}$; $V_{en}=1.8\text{ V}$; $T_{amb} = 25\text{ }^{\circ}\text{C}$; *input and output 50 Ω ; unless otherwise specified. All RF parameters have been characterized on the evaluation board described in this application note.*

Table 3.

Symbol	Parameter	Conditions	Min	Typ	Max	Unit
I_{CC}	supply current	$V_{en} 1.8\text{ V Pin-15 dBm}$		78.0		mA
G_P	power gain	2300 MHz 3500 MHz 4300 MHz		30.0 30.4 28.3		dB dB dB
$IP3_i$	Input third-order intercept point, tone spacing 100 MHz, $P_i = -15\text{ dBm}$	2300 MHz 3500 MHz 4300 MHz		36.5 35.5 34.0		dBm dBm dBm
$P_{L(1dB)}$	Output power at 1 dB gain compression	2300 MHz 3500 MHz 4300 MHz		26.1 27.1 26.1		dBm dBm dBm

5.2 S-parameters

The measured wideband S-parameters and Rollett stability factor K, are shown in the graphics in [Figure 8](#) to [Figure 11](#). The measured narrowband S-parameters and Rollett stability factor K, are shown in the graphics in [Figure 12](#) to [Figure 15](#). For the measurements, a typical BTS6201U EVB is used. All the S-parameter measurements have been carried out using the setup in [Figure 22](#).

BTS6201U wideband S-Parameters, and Rollett stability factor (typical values)

$V_{CC} = 5 V, P_i = -15 dBm$

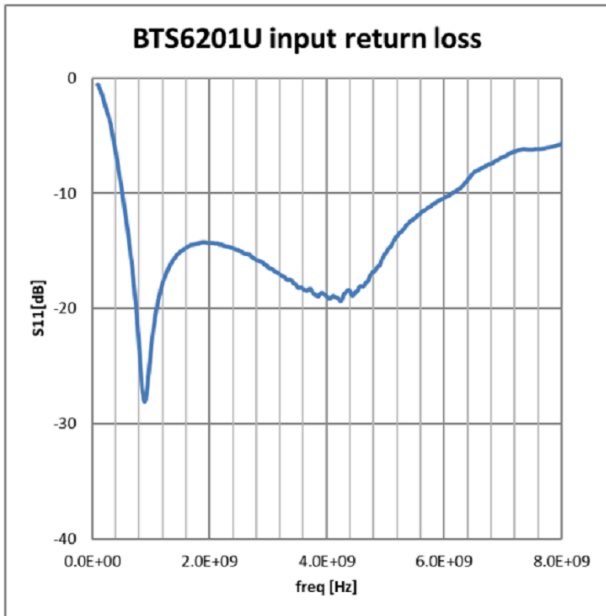

Figure 8. Input return loss

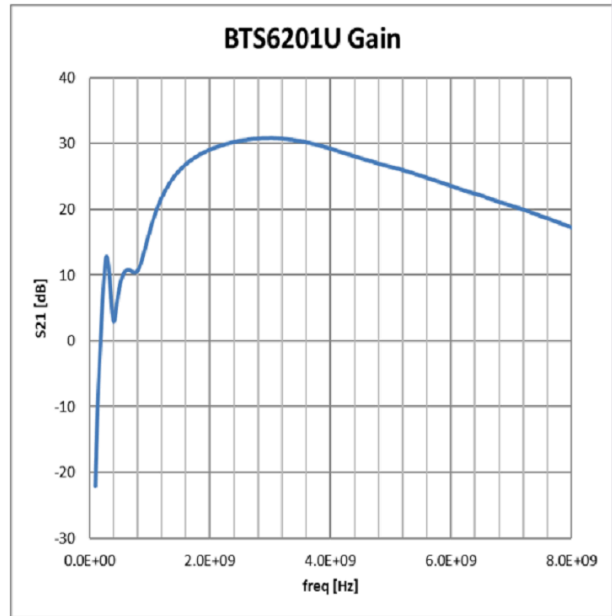

Figure 9. Gain wideband

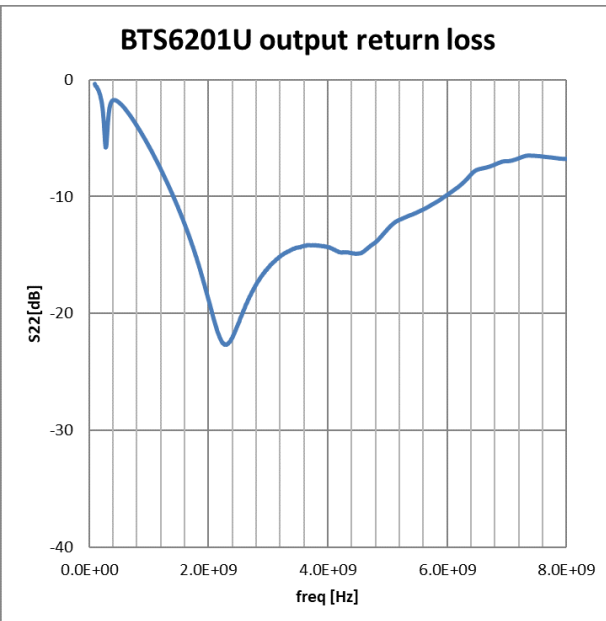

Figure 10. Output return loss

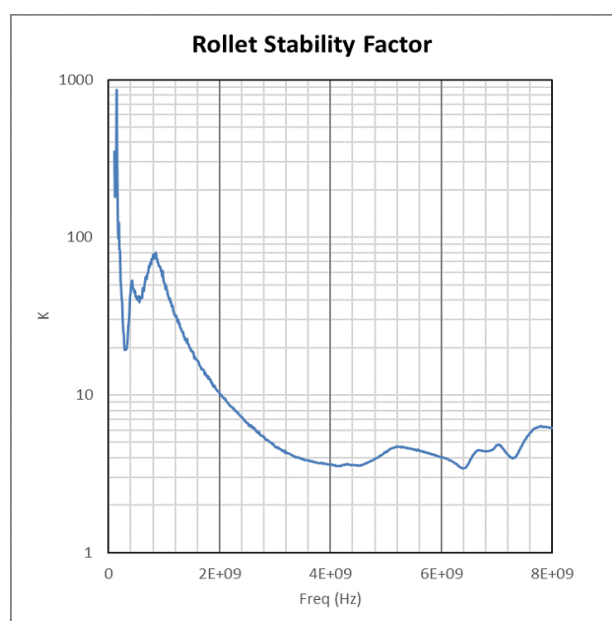

Figure 11. Rollett stability factor

BTS6201U narrowband S-Parameters, and Rollett stability factor (typical values)

$V_{CC} = 5\text{ V}$, $P_i = -15\text{ dBm}$

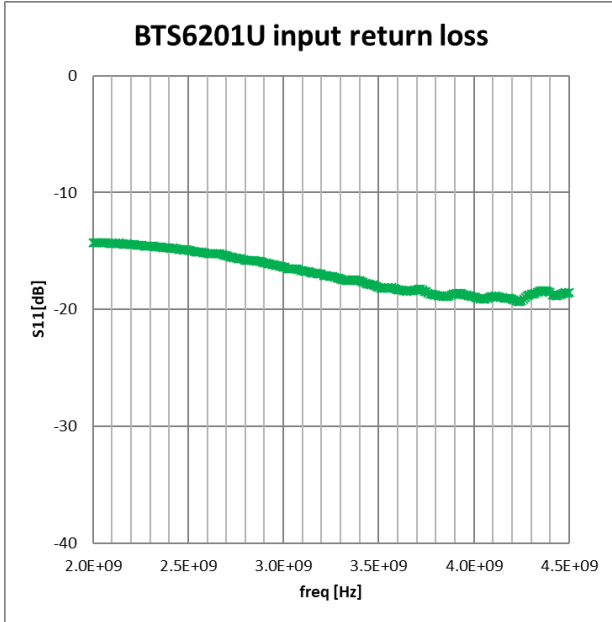

Figure 12. Narrowband Input return loss

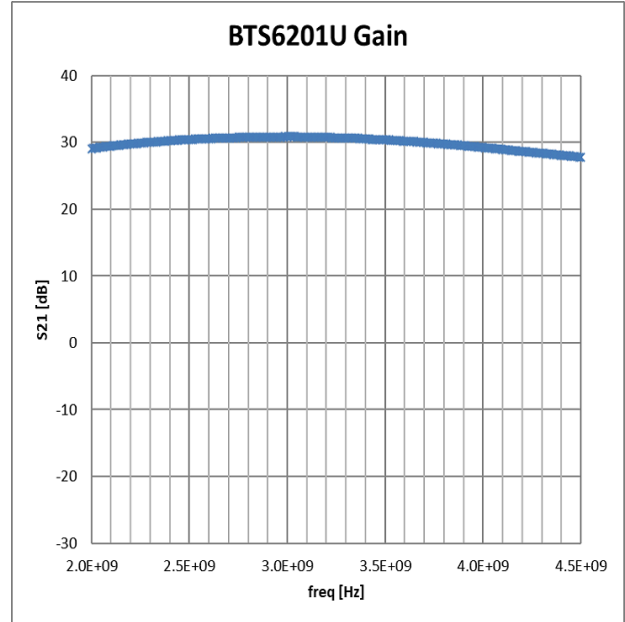

Figure 13. Narrowband gain

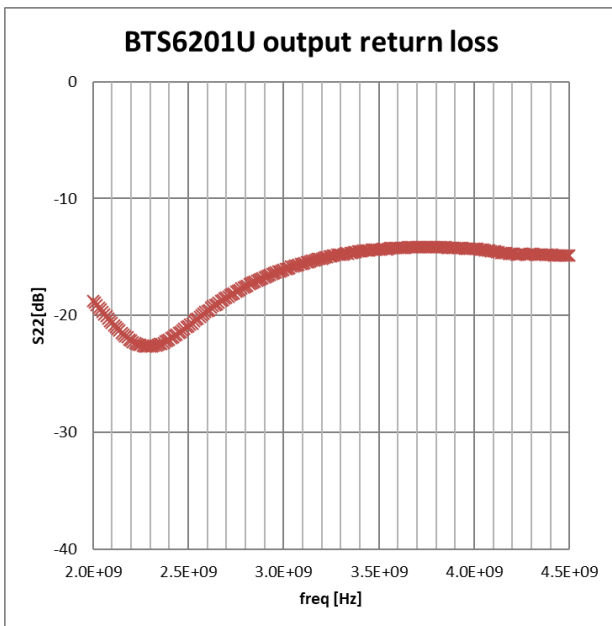

Figure 14. Narrowband output return loss

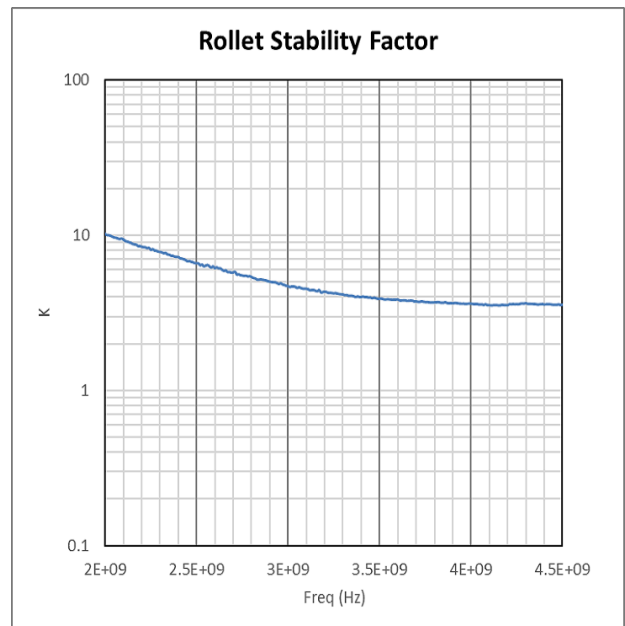

Figure 15. Rollett stability factor

5.3 1 dB Gain compression point

The 1 dB gain compression point has been measured using the set-up shown in [Figure 22](#).

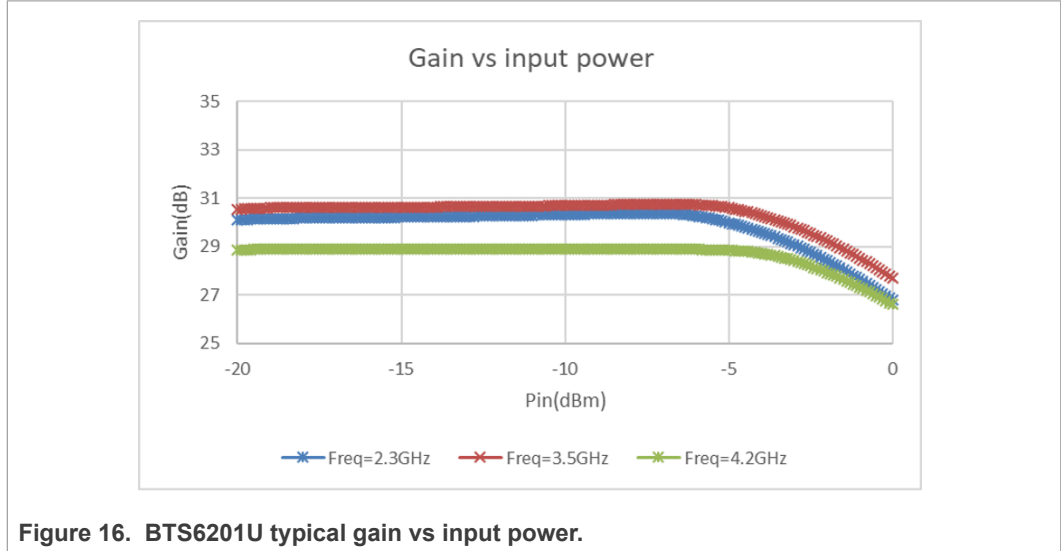

Figure 16. BTS6201U typical gain vs input power.

Table 4. BTS6201U Typical input and output 1 dB gain compression performance

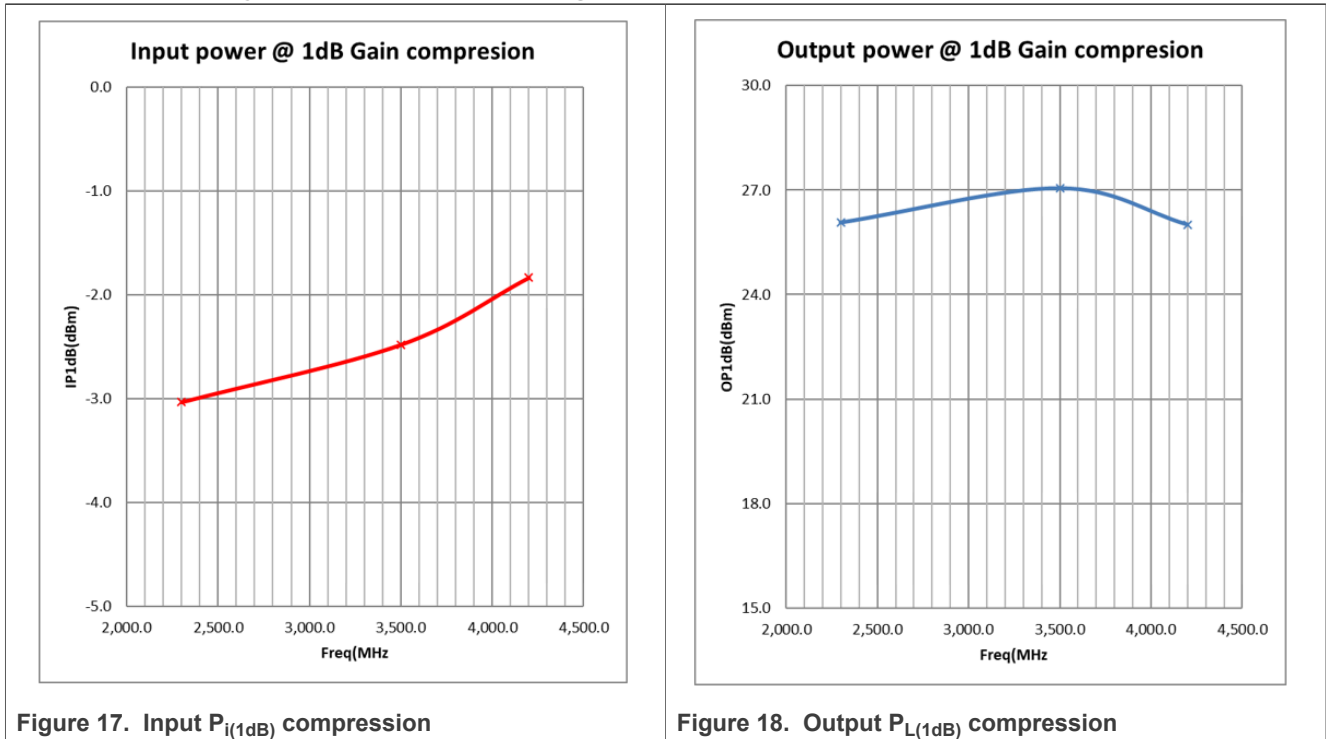

Figure 17. Input $P_{i(1dB)}$ compression

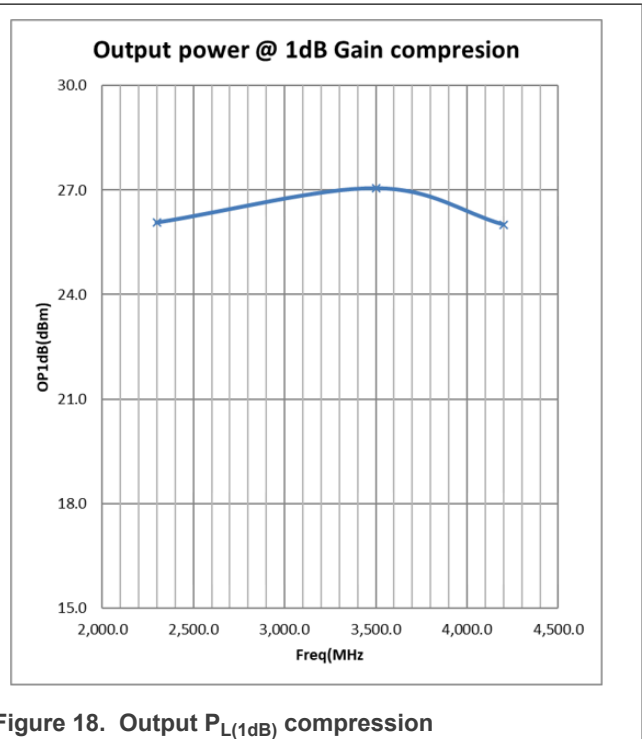
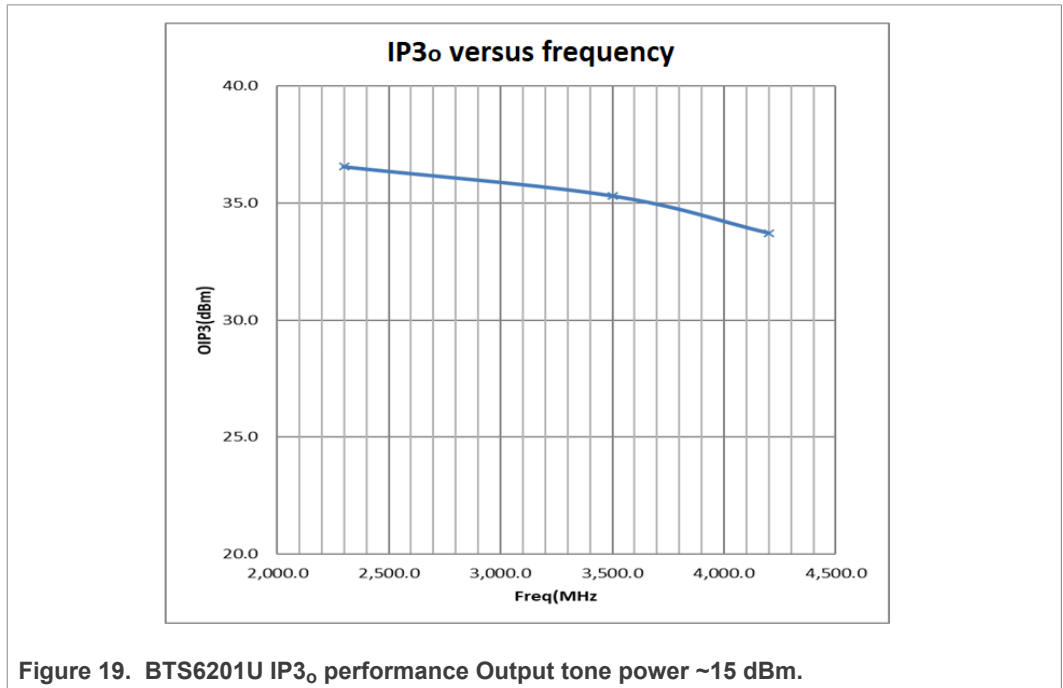

Figure 18. Output $P_{L(1dB)}$ compression

5.4 Third order intercept point

IP_{3o} is being measured using a setup like given in [Figure 23](#).



The typical device performance given in the data sheet is characterized on the evaluation board equal to the board described in this application note. The BTS6201U mounted on the evaluation board in the customer evaluation kit is industrially tested on the most important RF parameters. Like Gain, Noise Figure, IP_{3o}, and P_{L(1dB)}. The V_{ulp} pin is for internal use only. In the system, it can be grounded or left floating. On the EVB, it is connected to GND.

5.5 RF performance at different quiescent current

The BTS6201U is supplied with a feature to set the quiescent current with an external resistor R1 connected between the I_{set} pin (15) and ground. The board in the evaluation kit is supplied with a value of R1 = 1.2 kΩ. This paragraph gives typical RF performance at different R1 further more named R_{set} values and consequent different quiescent currents. The relation between quiescent current and the value of R_{set} is given in [Figure 20](#).

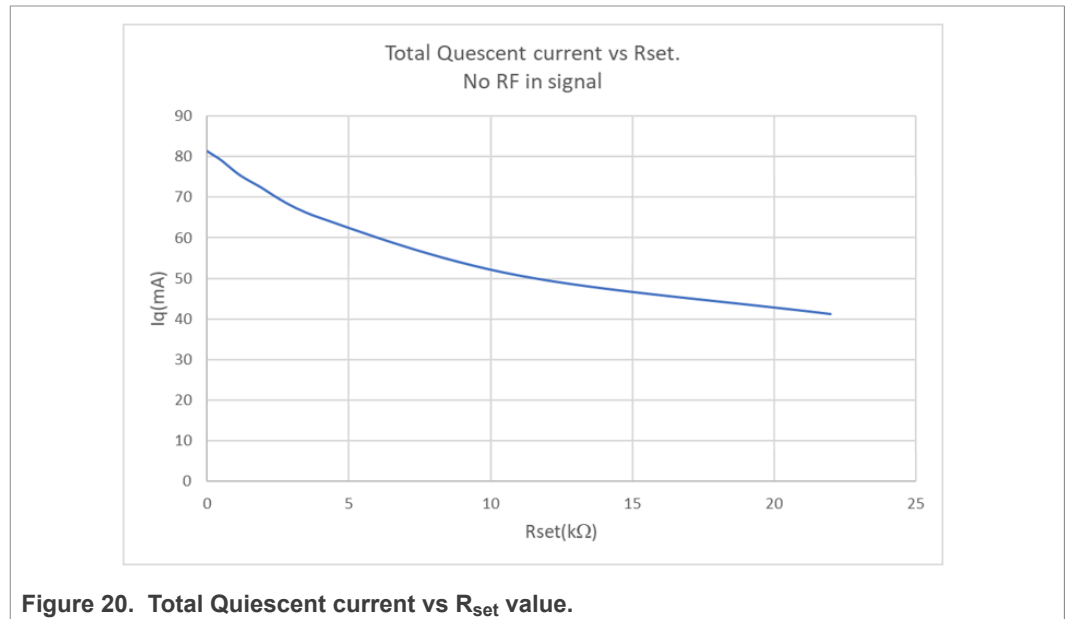

Typical performance at different R_{set}, RF freq = 2300 MHz

V_{CC} = 5.0 V; V_{en} = 1.8 V; T_{amb} = 25 °C; input and output 50 Ω; unless otherwise specified. All RF parameters have been characterized on the evaluation board described in this application note.

Table 5.

R _{set}	I _q	G _p	RL _i	RL _o	ISL _r	P _{o(sat)}	P _{L(1dB)}	IP3 _o Δf 10 MHz	IP3 _o Δf 100 MHz	ACLR 100 MHz	ACLR 200 MHz
kΩ	mA	dB	dB	dB	dB	dBm	dBm	dBm	dBm	dBc	dBc
0	81.4	29.6	14.4	27.5	53.6	26.6	26.0	37.4	36.4	-47.35	-39.77
0.47	79.3	29.5	14.4	25.2	53.5	26.7	26.2	36.7	35.9	-46.84	-39.49
0.82	77.3	29.5	14.4	25.2	53.5	26.6	26.1	36.2	35.6	-46.58	-39.32
1.2	75.3	29.4	14.3	22.8	53.8	26.5	26.2	35.7	35.3	-46.07	-39.10
1.8	72.9	29.2	14.3	21.2	53.7	26.5	26.2	35.0	34.7	-45.22	-38.52
3.9	65.2	28.8	14.3	17.6	54.0	26.4	26.4	32.8	32.9	-41.87	-36.70
11	50.8	27.7	14.2	12.4	54.8	26.8	26.6	28.8	29.1	-34.59	-32.01
22	41.3	26.5	14.1	9.4	55.7	26.8	26.7	25.7	26.2	-29.99	-28.52

Typical performance at different R_{set} , RF freq = 3500 MHz

$V_{CC} = 5.0\text{ V}$; $V_{en} = 1.8\text{ V}$; $T_{amb} = 25\text{ }^{\circ}\text{C}$; input and output $50\ \Omega$; unless otherwise specified. All RF parameters have been characterized on the evaluation board described in this application note.

Table 6.

R_{set}	I_q	G_p	RL_i	RL_o	ISL_r	$P_{o(sat)}$	$P_{L(1dB)}$	$IP3_o \Delta f$ 10 MHz	$IP3_o \Delta f$ 100 MHz	ACLR 100 MHz	ACLR 200 MHz
k Ω	mA	dB	dB	dB	dB	dBm	dBm	dBm	dBm	dBc	dBc
0	81.4	30.2	19.2	13.9	48.0	27.1	26.7	42.2	35.2	-45.33	-40.00
0.47	79.3	30.2	19.1	13.9	48.1	27.2	26.8	41.7	35.3	-45.60	-39.98
0.82	77.3	30.2	19.1	13.9	48.1	27.1	26.8	40.0	35.3	-45.96	-40.03
1.2	75.3	30.0	19.1	13.8	48.2	27.1	26.8	38.7	35.4	-46.10	-39.98
1.8	72.9	29.9	19.0	13.8	48.1	27.0	26.9	37.3	35.4	-46.10	-39.93
3.9	65.2	29.5	18.9	13.3	48.3	26.9	27.2	34.1	34.7	-45.21	-39.12
11	50.8	28.3	18.6	11.3	48.5	27.7	27.5	29.3	30.5	-36.96	-34.57
22	41.3	27.1	18.3	9.1	48.9	27.7	27.8	26.1	27.1	-31.22	-29.92

Typical performance at different R_{set} , RF freq = 4200 MHz

$f = 4200\text{ MHz}$; $V_{CC} = 5.0\text{ V}$; $T_{amb} = 25\text{ }^{\circ}\text{C}$; input and output $50\ \Omega$; unless otherwise specified. All RF parameters have been characterized on the evaluation board described in this application note.

Table 7.

R_{set}	I_q	G_p	RL_i	RL_o	ISL_r	$P_{o(sat)}$	$P_{L(1dB)}$	$IP3_o \Delta f$ 10 MHz	$IP3_o \Delta f$ 100 MHz	ACLR 100 MHz	ACLR 200 MHz
k Ω	mA	dB	dB	dB	dB	dBm	dBm	dBm	dBm	dBc	dBc
0	81.4	28.4	18.1	14.3	45.5	26.4	25.9	33.9	33.8	-42.07	-37.90
0.47	79.3	28.3	18.0	14.2	45.6	26.5	26.0	33.8	34.0	-42.42	-38.01
0.82	77.3	28.3	18.0	14.2	45.6	26.4	26.0	33.9	34.2	-42.63	-38.02
1.2	75.3	28.2	18.0	14.0	45.5	26.4	26.0	33.9	34.4	-42.47	-38.13
1.8	72.9	28.0	17.9	13.8	45.6	26.4	26.1	34.0	34.7	-42.64	-38.20
3.9	65.2	27.6	17.7	13.2	45.6	26.4	26.3	35.4	36.6	-42.79	-38.31
11	50.8	26.5	17.4	11.2	45.6	26.8	26.6	28.8	30.8	-38.42	-36.00
22	41.3	25.4	17.0	9.1	45.7	26.8	26.7	22.5	26.8	-33.26	-31.77

5.6 Required Equipment

For the BTS6201U evaluation, the following equipment is needed.

- 1 DC power supply 5 V, 500 mA.
- 1 DC power supply 1.8 V, 5 mA for the enable voltage V_{en}
- A network analyzer for S-parameter measurements, and $P_{L(1dB)}$ measurements.
- 2 RF generators up to 12 GHz, and a combiner for IP3 measurements
- A spectrum analyzer with NF option for IP3 and Noise figure measurements.
- High Quality RF cables with SMA/3.5 mm RF connectors.
- DC currents meters.

After switching on the power supply the BTS6201U comes up in the quiescent current, 1.8 V enable voltage must be applied. Preferable the supply start-up sequence is as follows.

First switch on V_{CC1} , second V_{CC2} , and third V_{en} .

The typical current at 5 V supply is 78 mA, in power down-mode V_{en} (0 V) - 0.5 mA.

5.7 Connection and setup

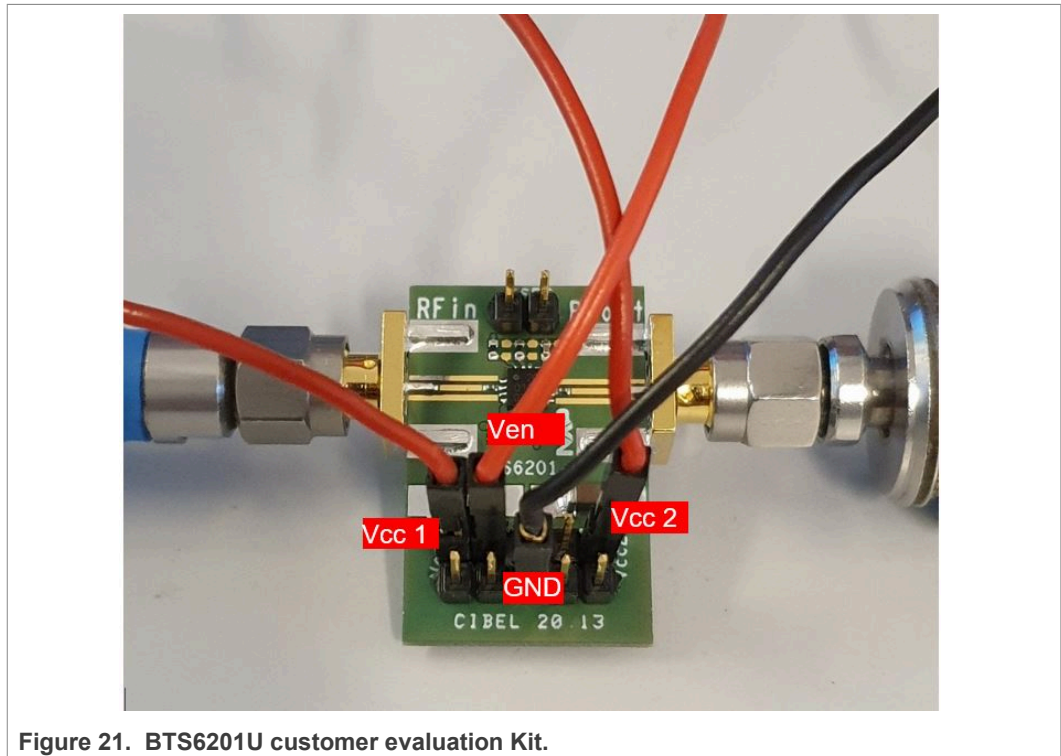

Figure 21. BTS6201U customer evaluation Kit.

1. Connect the EVB to a calibrated network analyzer see [Figure 21](#), we advise the following settings for S-parameter measurements:
 - a. Port power -15 dBm
 - b. IF Bandwidth 100 Hz
2. For the 1 dB gain compression evaluation, we advise the following NWA setting
 - a. Port 1 power sweep -20 dBm up to 0 dBm
 - b. Port 2, 20 dB attenuation on the receiver port b2.
 - c. IF Bandwidth 100 Hz.
3. Gain and 1 dB gain compression data can also be determined using an RF generator and spectrum analyzer.
4. Turn on the DC power supplies and it should read typical $I_{cc} = 78$ mA.
5. Nonlinear distortion measurements IP3 can be performed with a set-up like is depicted in [Figure 23](#). The following settings are recommended to perform the IP3 evaluation.
 - a. -15 dBm for each fundamental tone.
 - b. RBW and VBW of the spectrum analyzer 100 Hz
 - c. Tone spacing 100 MHz

Evaluation measurement setups

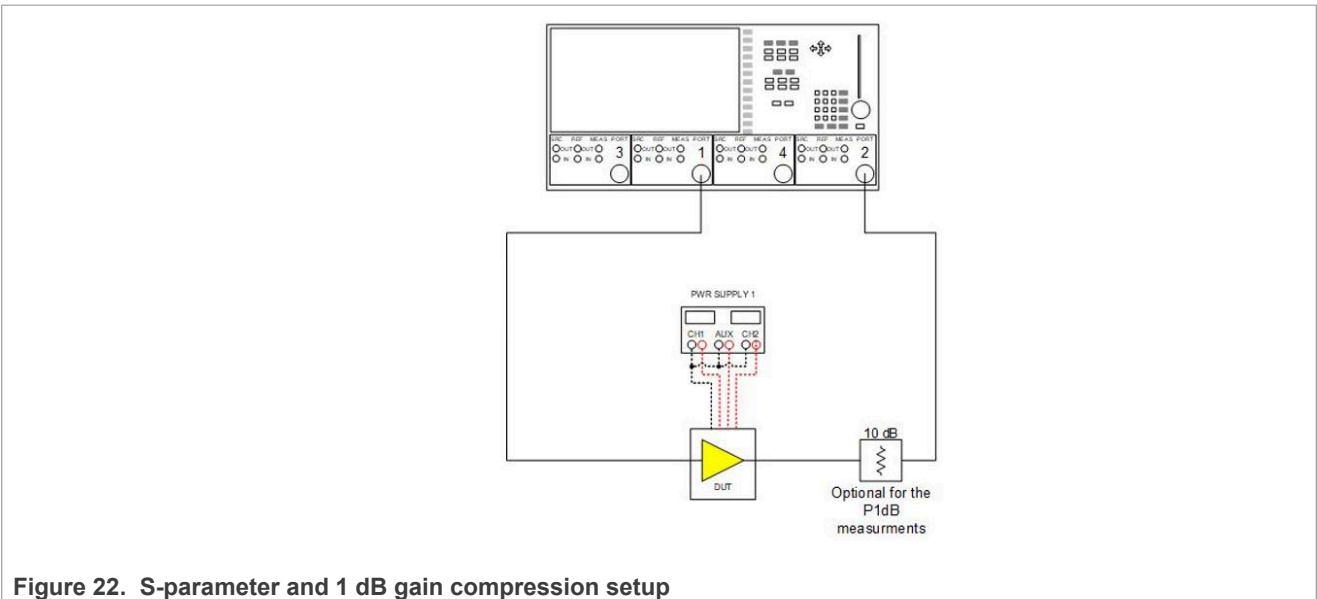

Figure 22. S-parameter and 1 dB gain compression setup

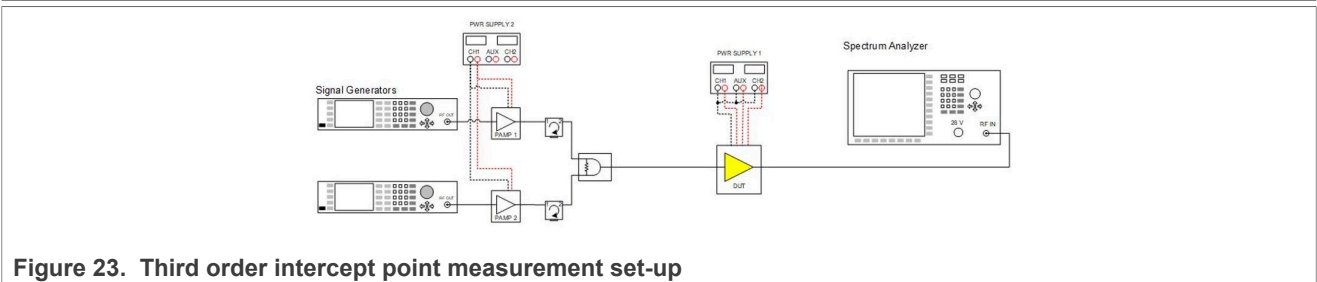

Figure 23. Third order intercept point measurement set-up

6 Legal information

6.1 Definitions

Draft — A draft status on a document indicates that the content is still under internal review and subject to formal approval, which may result in modifications or additions. NXP Semiconductors does not give any representations or warranties as to the accuracy or completeness of information included in a draft version of a document and shall have no liability for the consequences of use of such information.

6.2 Disclaimers

Limited warranty and liability — Information in this document is believed to be accurate and reliable. However, NXP Semiconductors does not give any representations or warranties, expressed or implied, as to the accuracy or completeness of such information and shall have no liability for the consequences of use of such information. NXP Semiconductors takes no responsibility for the content in this document if provided by an information source outside of NXP Semiconductors. In no event shall NXP Semiconductors be liable for any indirect, incidental, punitive, special or consequential damages (including - without limitation - lost profits, lost savings, business interruption, costs related to the removal or replacement of any products or rework charges) whether or not such damages are based on tort (including negligence), warranty, breach of contract or any other legal theory. Notwithstanding any damages that customer might incur for any reason whatsoever, NXP Semiconductors' aggregate and cumulative liability towards customer for the products described herein shall be limited in accordance with the Terms and conditions of commercial sale of NXP Semiconductors.

Right to make changes — NXP Semiconductors reserves the right to make changes to information published in this document, including without limitation specifications and product descriptions, at any time and without notice. This document supersedes and replaces all information supplied prior to the publication hereof.

Suitability for use — NXP Semiconductors products are not designed, authorized or warranted to be suitable for use in life support, life-critical or safety-critical systems or equipment, nor in applications where failure or malfunction of an NXP Semiconductors product can reasonably be expected to result in personal injury, death or severe property or environmental damage. NXP Semiconductors and its suppliers accept no liability for inclusion and/or use of NXP Semiconductors products in such equipment or applications and therefore such inclusion and/or use is at the customer's own risk.

Applications — Applications that are described herein for any of these products are for illustrative purposes only. NXP Semiconductors makes no representation or warranty that such applications will be suitable for the specified use without further testing or modification. Customers are responsible for the design and operation of their applications and products using NXP Semiconductors products, and NXP Semiconductors accepts no liability for any assistance with applications or customer product design. It is customer's sole responsibility to determine whether the NXP Semiconductors product is suitable and fit for the customer's applications and products planned, as well as for the planned application and use of customer's third party customer(s). Customers should provide appropriate design and operating safeguards to minimize the risks associated with their applications and products. NXP Semiconductors does not accept any liability related to any default, damage, costs or problem which is based on any weakness or default in the customer's applications or products, or

the application or use by customer's third party customer(s). Customer is responsible for doing all necessary testing for the customer's applications and products using NXP Semiconductors products in order to avoid a default of the applications and the products or of the application or use by customer's third party customer(s). NXP does not accept any liability in this respect.

Export control — This document as well as the item(s) described herein may be subject to export control regulations. Export might require a prior authorization from competent authorities.

Evaluation products — This product is provided on an "as is" and "with all faults" basis for evaluation purposes only. NXP Semiconductors, its affiliates and their suppliers expressly disclaim all warranties, whether express, implied or statutory, including but not limited to the implied warranties of non-infringement, merchantability and fitness for a particular purpose. The entire risk as to the quality, or arising out of the use or performance, of this product remains with customer. In no event shall NXP Semiconductors, its affiliates or their suppliers be liable to customer for any special, indirect, consequential, punitive or incidental damages (including without limitation damages for loss of business, business interruption, loss of use, loss of data or information, and the like) arising out of the use of or inability to use the product, whether or not based on tort (including negligence), strict liability, breach of contract, breach of warranty or any other theory, even if advised of the possibility of such damages. Notwithstanding any damages that customer might incur for any reason whatsoever (including without limitation, all damages referenced above and all direct or general damages), the entire liability of NXP Semiconductors, its affiliates and their suppliers and customer's exclusive remedy for all of the foregoing shall be limited to actual damages incurred by customer based on reasonable reliance up to the greater of the amount actually paid by customer for the product or five dollars (US\$5.00). The foregoing limitations, exclusions and disclaimers shall apply to the maximum extent permitted by applicable law, even if any remedy fails of its essential purpose.

Translations — A non-English (translated) version of a document is for reference only. The English version shall prevail in case of any discrepancy between the translated and English versions.

Security — Customer understands that all NXP products may be subject to unidentified or documented vulnerabilities. Customer is responsible for the design and operation of its applications and products throughout their lifecycles to reduce the effect of these vulnerabilities on customer's applications and products. Customer's responsibility also extends to other open and/or proprietary technologies supported by NXP products for use in customer's applications. NXP accepts no liability for any vulnerability. Customer should regularly check security updates from NXP and follow up appropriately. Customer shall select products with security features that best meet rules, regulations, and standards of the intended application and make the ultimate design decisions regarding its products and is solely responsible for compliance with all legal, regulatory, and security related requirements concerning its products, regardless of any information or support that may be provided by NXP. NXP has a Product Security Incident Response Team (PSIRT) (reachable at PSIRT@nxp.com) that manages the investigation, reporting, and solution release to security vulnerabilities of NXP products.

6.3 Trademarks

Notice: All referenced brands, product names, service names and trademarks are the property of their respective owners.

NXP — wordmark and logo are trademarks of NXP B.V.

Contents

1	Front matter	2
2	Introduction	2
2.1	Ordering information	2
3	Product description	3
4	Application board	4
4.1	Application circuit	4
4.2	PCB Layout information and component selection	5
4.2.1	Evaluation board layout	5
4.2.2	PCB stack and recommended footprint	6
4.3	Bill of materials	6
5	Evaluating the BTS6201U	7
5.1	Typical results	7
5.2	S-parameters	8
5.3	1 dB Gain compression point	10
5.4	Third order intercept point	11
5.5	RF performance at different quiescent current	12
5.6	Required Equipment	14
5.7	Connection and setup	15
6	Legal information	17

Please be aware that important notices concerning this document and the product(s) described herein, have been included in section 'Legal information'.

© NXP B.V. 2021.

All rights reserved.

For more information, please visit: <http://www.nxp.com>

For sales office addresses, please send an email to: salesaddresses@nxp.com

Date of release: 23 February 2021

Document identifier: DOC_ID