



# AN10579

## Driving LED light bars using NXP solutions

Rev. 01 — 1 February 2007

Application note

### Document information

Info	Content
<b>Keywords</b>	LED, LED controller, I2C, light bar, RGB, color mixing, architectural lighting, LED lighting, LED driver, PWM, STARplug+, SMPS, power conversion
<b>Abstract</b>	Description of Avago light bars, driving high brightness color LED strings for color mixing and lighting applications using NXP Semiconductors PCA9633 LED driver is discussed. An offline regulated power supply for the LEDs is also included.

**Revision history**

<b>Rev</b>	<b>Date</b>	<b>Description</b>
01	20070201	Application note; initial version.

**Contact information**

For additional information, please visit: <http://www.nxp.com>

For sales office addresses, please send an email to: [salesaddresses@nxp.com](mailto:salesaddresses@nxp.com)

## 1. Introduction

---

Light Emitting Diodes (LEDs) have been used in electronic systems for many years primarily as indicator lights on electronic devices. Recent advances in high brightness and color LEDs have made them suitable for a wide range of new applications. Today, LEDs are being used in applications in cell phones and media players for fun lighting to architectural/commercial lighting to replace conventional light sources. Key enablers driving penetration of LED lighting is the availability of high brightness LEDs and intelligent LED controllers. Product designers incorporating high brightness LEDs face many challenges. Among them, thermal management, driver scheme/topology, device matching for color balance and consistency. Manufactures and OEMs alike are starting to make available LED modules consisting of clusters or strings of many LEDs of different colors in single packages.

One such product family is ADJD-MJ00/ADJD-MJ10 RGB light bars from Avago Technologies. This application note describes how NXP power solutions and intelligent LED controllers can be used to drive the LED light bars to provide programmable color mixing and brightness control features.

## 2. LED light bars

---

Avago RGB LED Light Source ADJD-MJ00/ADJD-MJ10 is a high performance device that can be operated at high driving current. It comes with a plug-and-play electrical connector.

The built-in heat sink and the mechanical mounting features simplify the thermal management of a lighting solution. This enables effective heat transfer and maintain LED junction below maximum allowed temperature. Red, Green and Blue colors premix in the reflector cavity to produce required color. The reflector cavity design maximizes the light extraction as well as the color mixing. Together with closely pitched LED dice, the color mixing is best of its class.

### 2.1 Electrical configuration

The light bar consists of four LED strings. Each LED string consists of ten LEDs connected in series, except for red which consist of 10 pairs of parallel connected LEDs. Each pair of parallel connected LEDs can be considered equivalent to a single large LED. That is, for RED color, between R+ and R- terminal, there is an equivalent of ten series-connected red LEDs.

The LED strings are:

Red color: Connect with R+ and R- terminals.

Green color: Connect with G1+ and G1- terminals.

Green color: Connect with G2+ and G2- terminals.

Blue color: Connect with B+ and B- terminals.

The circuit is shown in [Figure 1](#).

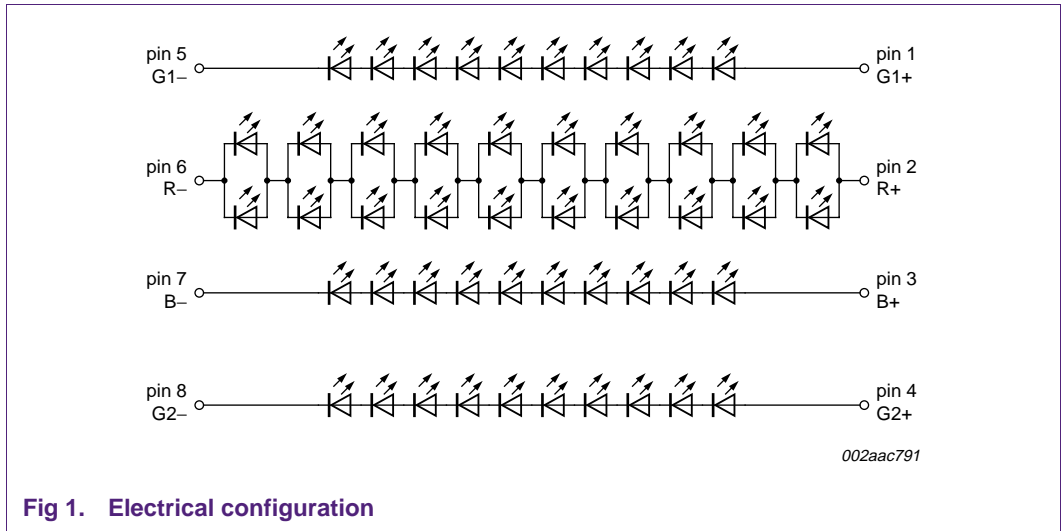

**Fig 1. Electrical configuration**

## 2.2 Color configuration

The arrangement of Red, Green and Blue LEDs within the light bar is shown in [Figure 2](#).

position	1	2	3	4	5	6	7	8	9	10	11	12	13	14	15	16	17	18	19	20	21	22	23	24	25	26	27	28	29	30	31	32	33	34	35	36	37	38	39	40	41	42	43	44	45	46	47	48	49	50
color	G	B	R	R	G	G	R	R	B	G	G	R	R	B	G	G	R	R	B	G	G	R	R	B	G	G	R	R	B	G	G	R	R	B	G	G	R	R	B	G	G	R	R	B	G	G	R	R	B	G

002aac792

**Fig 2. Color arrangement**



The three colors in the LED light source will mix to form a resultant color. Depending on the mix ratio, any color within the color gamut of the LED can be obtained. The color gamut of the LED light source is the triangle formed by the three colors points on the CIE chromaticity chart. The three color points are from Red, Green and Blue LED color.

### 2.3 Drive configuration

Figure 4 shows a basic drive circuit for the light bar.

A fixed voltage is applied to the positive terminal of each LED string through a resistor. The negative terminal is connected to GND. The value of the resistor is determined by the current needed and the input voltage, according to Equation 1:

$$R = \frac{V_I - V_F}{I_F} \tag{1}$$

The current required for red, green and blue color LEDs are determined from the required luminous intensity needed to obtain the color. The forward voltage drop,  $V_F$  of the LED strings is determined from the  $I_F / V_F$  graphs in the specification. The resistor required can thus be calculated from Equation 1.

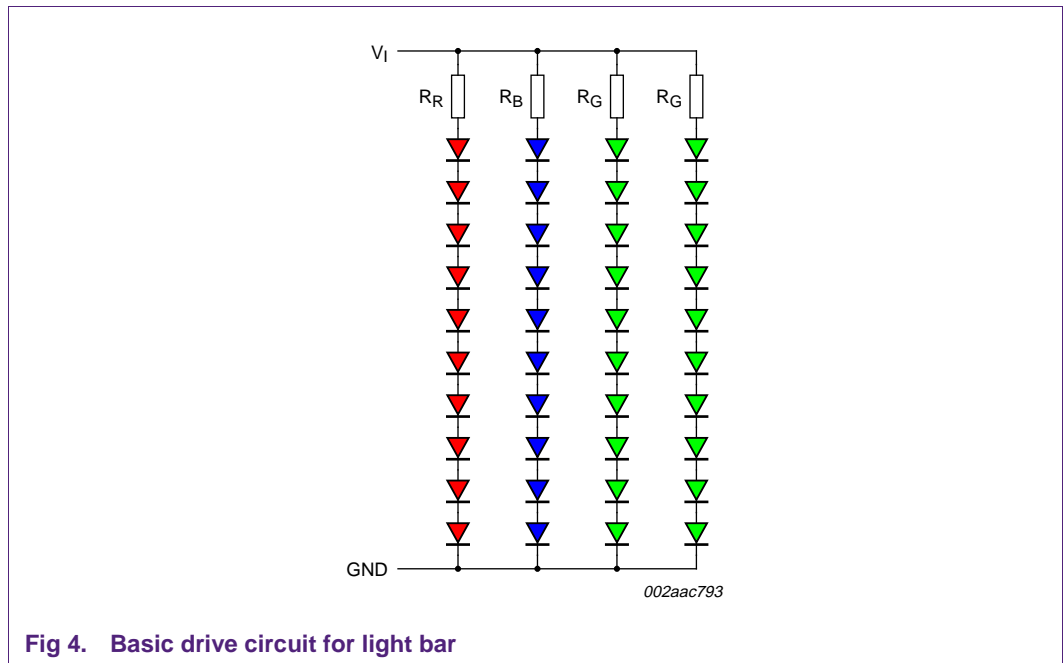

Fig 4. Basic drive circuit for light bar

To adjust the resultant color and the overall brightness of the light bar, the intensities of each string needs to be controllable. This can be accomplished by Pulse Width Modulated (PWM) power switches on each channel as shown in Figure 5. While the PWM control of LED strings can be implemented using a microcontroller or other hardware logic; using a PCA9633 is less complex, easier to implement and provides a simpler and flexible (scalable) design, especially, when multiple PWMs are involved.

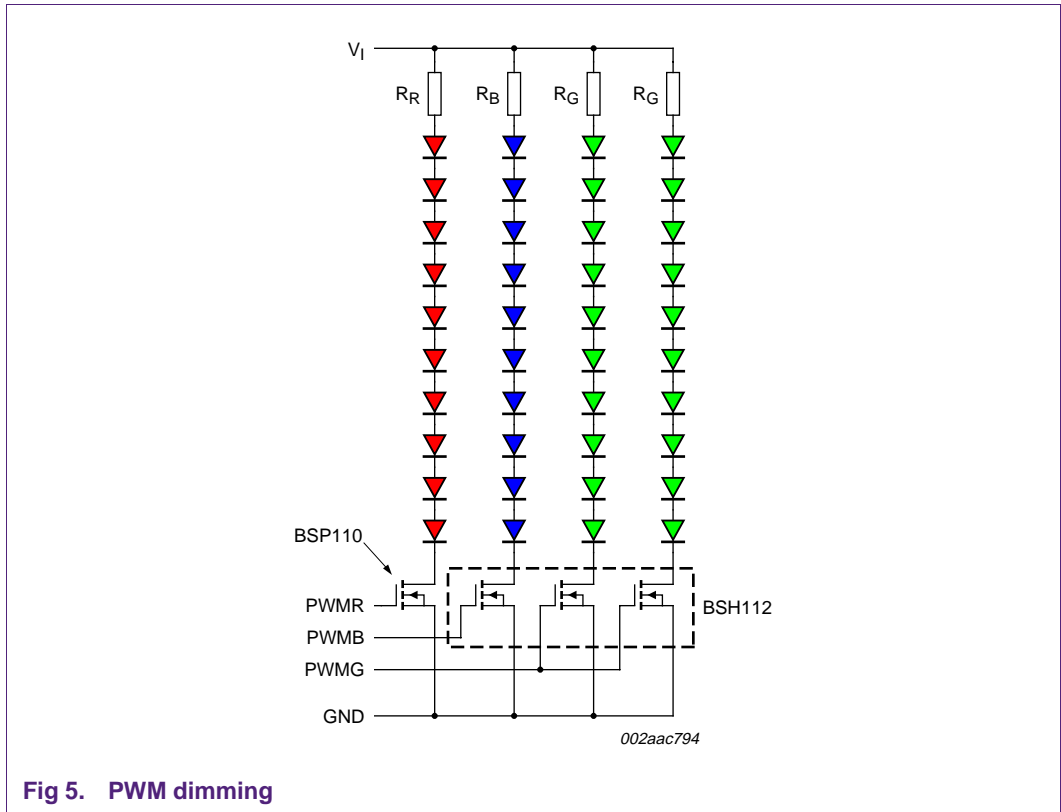

Fig 5. PWM dimming

### 3. The PCA9633 intelligent LED controller

#### 3.1 Programmable RGGB/RGBA controller

The PCA9633 is an I<sup>2</sup>C-bus controlled 4-bit LED driver optimized for Red/Green/Green/Blue (RGGB) or Red/Green/Blue/Amber (RGBA) color mixing applications. It is equipped with four individual PWM controllers. Each LED output has its own 8-bit resolution (256 steps) fixed frequency Individual PWM controller that operates at 97 kHz with a duty cycle that is adjustable from 0 % to 99.6 % to allow the LED to be set to a specific brightness value. A fifth 8-bit resolution (256 steps) Group PWM controller has both a fixed frequency of 190 Hz and an adjustable frequency between 24 Hz to once every 10.73 seconds with a duty cycle that is adjustable from 0 % to 99.6 % that is used to either dim or blink all LEDs with the same value.

Each LED output can be off, on (no PWM control), set at its Individual PWM controller value or at both Individual and Group PWM controller values. The LED output driver can be programmed to be either open-drain with a 25 mA current sink capability at 5 V or totem-pole with a 25 mA sink, 10 mA source capability at 5 V. The PCA9633 operates with a supply voltage range of 2.3 V to 5.5 V and the outputs are 5.5 V tolerant.

### 3.2 Functional description

The PCA9633 is configured and controlled by sending commands to the device via an I<sup>2</sup>C-bus.

Like all I<sup>2</sup>C-bus compatible ICs, PCA9633 has the following advantages:

- Only two bus lines are required; a serial data line (SDA) and a serial clock line (SCL).
- The simple 2-wire serial I<sup>2</sup>C-bus minimizes interconnections so ICs have fewer pins and there are not so many PCB tracks. Result: smaller and less expensive PCBs.
- Each device connected to the bus is software-addressable by a unique address.
- Multiple PCA9633 devices can be connected to the same I<sup>2</sup>C-bus without the need for address decoders or chip select pins.
- Reduced software development time due to simple command byte sequences needed for the control.
- Since PCA9633 supports Fast-mode Plus I<sup>2</sup>C-bus, serial, 8-bit oriented, bidirectional data transfers can be made at up to 1 Mbit/s and is backward compatible with existing Fast-mode and Standard-mode I<sup>2</sup>C-bus devices.
- The built-in 10× bus drive capability allows longer distance transmission, larger number of components on a single bus needed in architectural lighting and gaming.
- Built-in PWM oscillator minimizes component count and cost.
- Allows glueless connection of external FETs for driving high brightness LED strings and light bars.
- Special Group PWM control feature allows control of multiple units with simple software commands.

### 3.3 Basic electrical configuration for using a PCA9633

A typical application circuit used to drive LEDs is shown in [Figure 6](#).

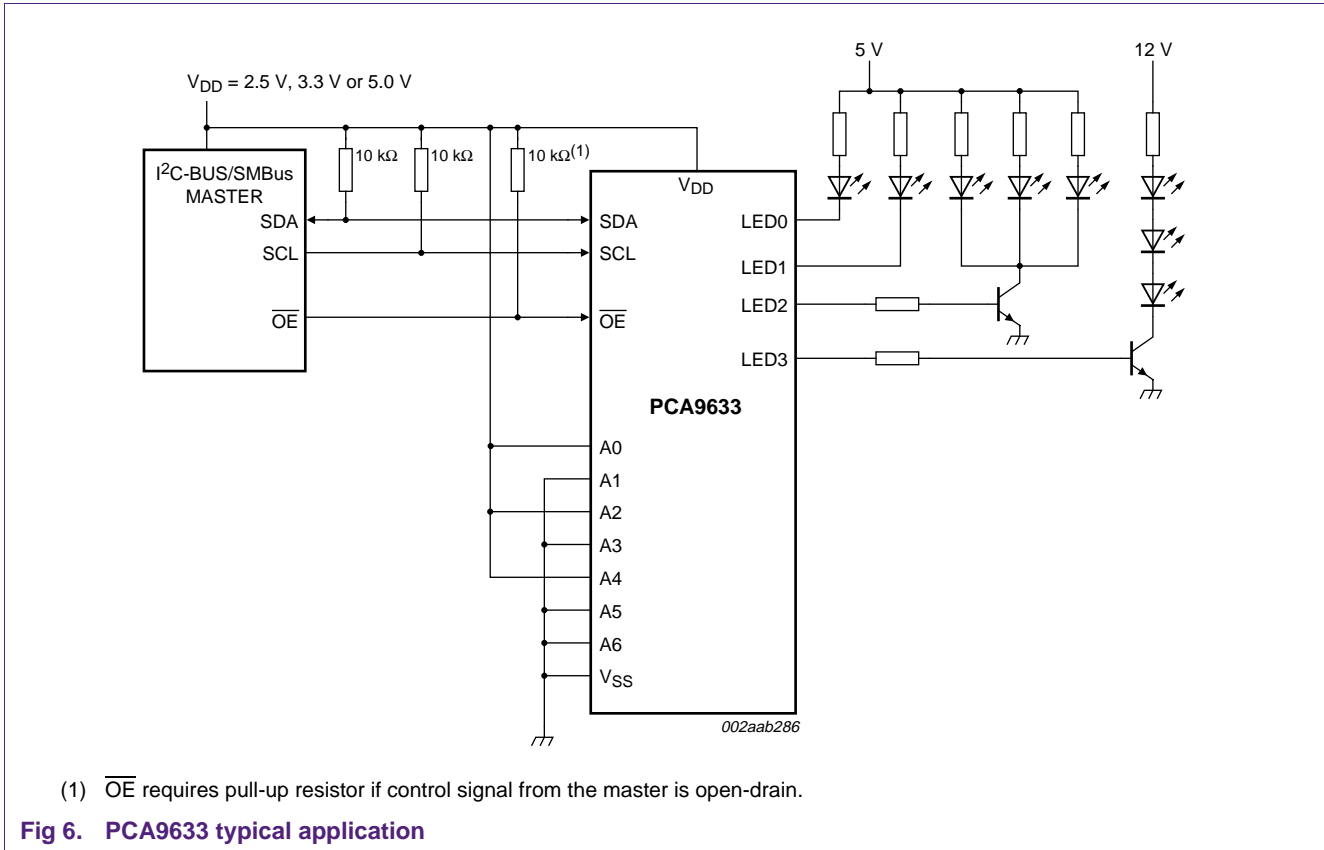

The PCA9633 acts like an I<sup>2</sup>C-bus slave. The I<sup>2</sup>C-bus master configures the settings for the 4 PWMs and the LED outputs by sending command bytes to the PCA9633 via the 2-wire I<sup>2</sup>C-bus. For detailed information on the PCA9633 including register definition and command set, refer to the PCA9633 data sheet.



### 3.4 Driving light bars with a PCA9633

Each LED string in the ADJD-MJ00/ADJD-MJ10 RGB light bar consists of ten LEDs connected in series. The total forward voltage drop across the LED string for each color for their rated DC forward current is given in [Table 1](#).

**Table 1. Electrical characteristics**

$T_j = 25\text{ °C}$

Color	Forward voltage, $V_F$ <sup>[1][2]</sup>			Testing forward current, $I_F$ <sup>[1]</sup>	Dynamic resistance, $R_{dyn}$ <sup>[3][4]</sup>
	Min	Typ	Max		
AllnGaP red	25 V	29 V	35 V	300 mA	26 $\Omega$
InGaN green G1	30 V	35 V	45 V	150 mA	31 $\Omega$
InGaN green G2	30 V	35 V	45 V	150 mA	31 $\Omega$
InGaN blue	30 V	35 V	45 V	150 mA	31 $\Omega$

[1] Per individual string.

[2]  $V_F$  tolerance is  $\pm 1.0$  V.

[3] Measured at  $T_j = 25\text{ °C}$ , applicable from  $I_F = 50$  mA onwards.

[4] Dynamic resistance is the inverse slope of the forward current versus forward voltage characteristic.

A DC supply rail of 45 V or greater is needed to drive the LED strings.

While many power converter solutions are available in the market, normally the PWMs are not offered as a part of the solution.

An application circuit for driving the LED strings using the PCA9633 PWMs is shown in [Figure 7](#).

The PCA9633 LED output drivers are 5.5 V only tolerant and can sink up to 25 mA at 5 V and source 10 mA. External switching FETs are used to drive the LED strings. These FETs must be able to switch the currents listed in [Table 1](#) and also their drain voltages must be able to withstand 45 V minimum.

When external FETs are used with the LED output pins of a PCA9633, output polarity inversion is needed. PCA9633 incorporates INVRT bit (MODE2 register) to accomplish this. For driving N-type FETs as shown in [Figure 5](#), the INVRT and the OUTDRV bits must both be set to logic 1.

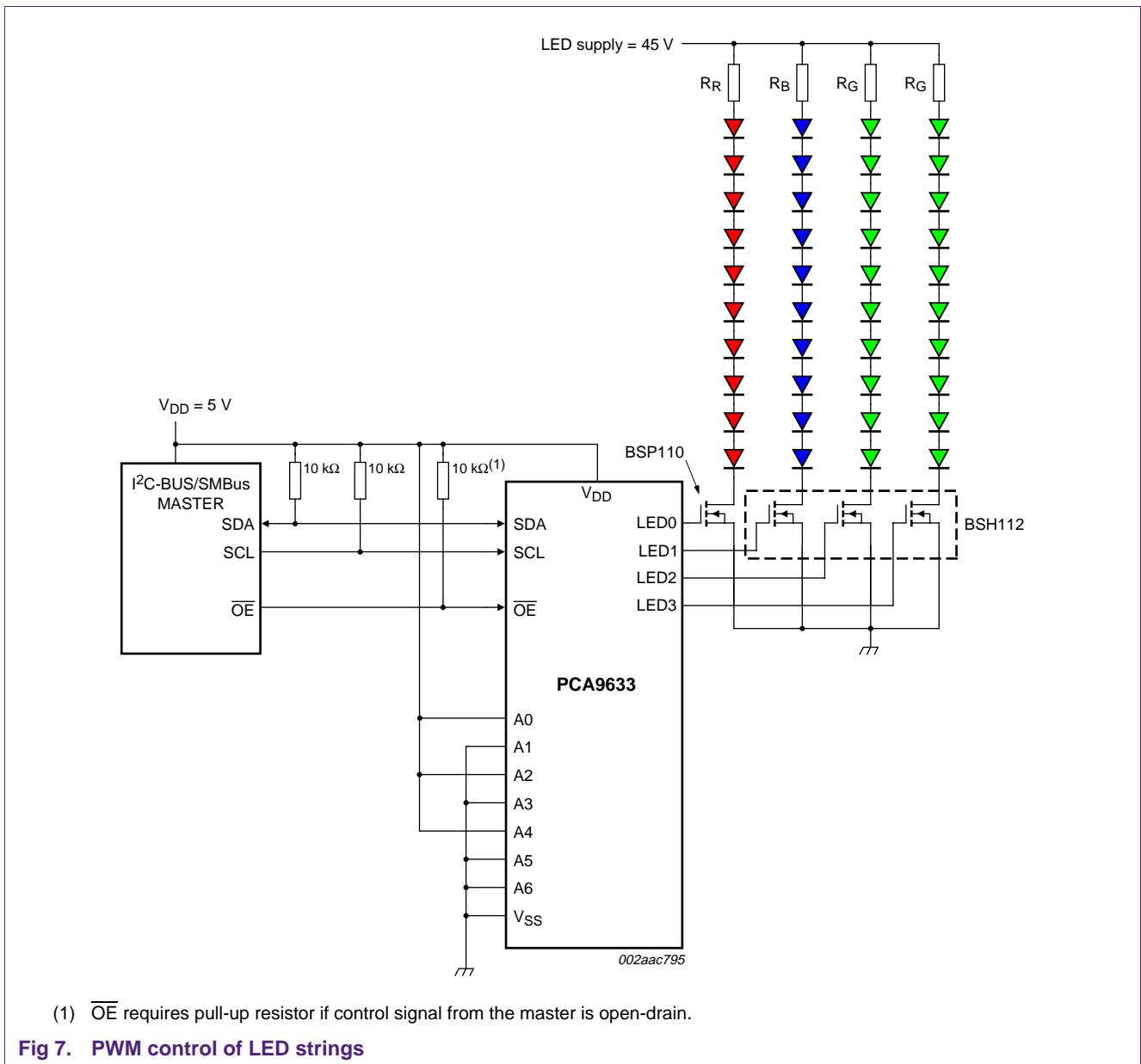

### 3.5 Individual brightness control with group dimming/blinking with PCA9633

A 97 kHz fixed frequency signal with programmable duty cycle (8 bits, 256 steps) is used to control individually the brightness for each LED string. On top of this signal (see [Figure 8](#)), one of the following signals can be superimposed (this signal can be applied to the 4 LED outputs):

- A lower 190 Hz fixed frequency signal with programmable duty cycle (8 bits, 256 steps) is used to provide a global brightness control.
- A programmable frequency signal from 24 Hz to  $\frac{1}{10.73}$  Hz (8 bits, 256 steps) with programmable duty cycle (8 bits, 256 steps) is used to provide a global blinking control.

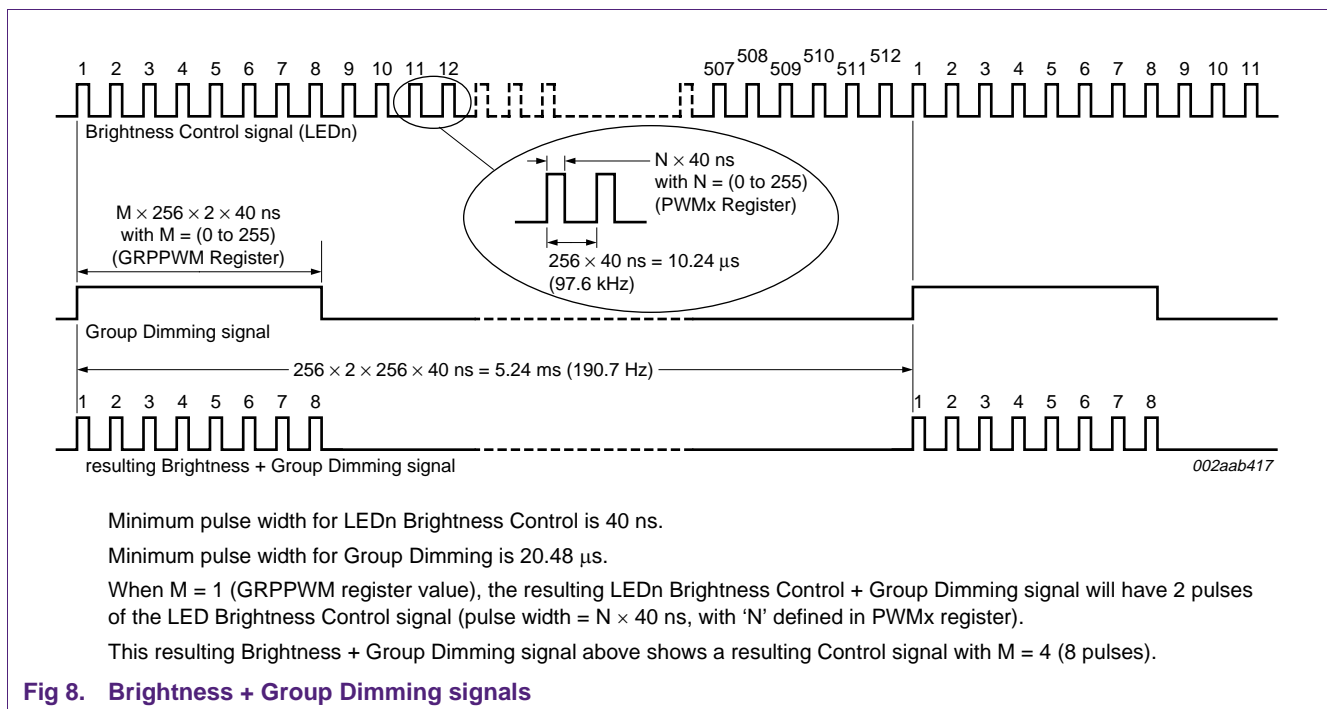

**Fig 8. Brightness + Group Dimming signals**

### 3.6 Color mixing and control

Color mixing is based on the RGB additive color model as shown in [Figure 9](#).

RGB model uses additive color mixing, because it describes what kind of light needs to be emitted to produce a given color.

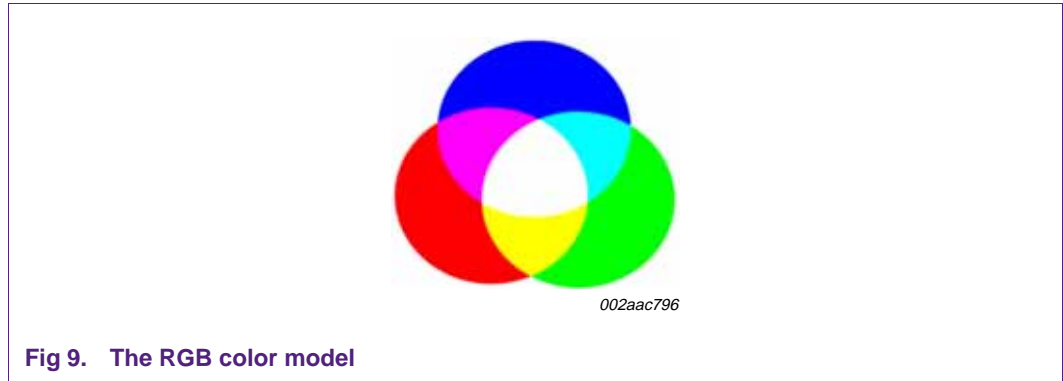

Fig 9. The RGB color model

Various ratios of the emitted light for the 3 colors determine the resulting color.

Human eye sees the sum of primary colors' average brightness:

$$X \% \text{ Red} + Y \% \text{ Green} + Z \% \text{ Blue}$$

Brightness of each color LED string is adjusted using the individual PWMs on the PCA9633. [Figure 10](#) shows an example waveform for color mixing using PWMs.

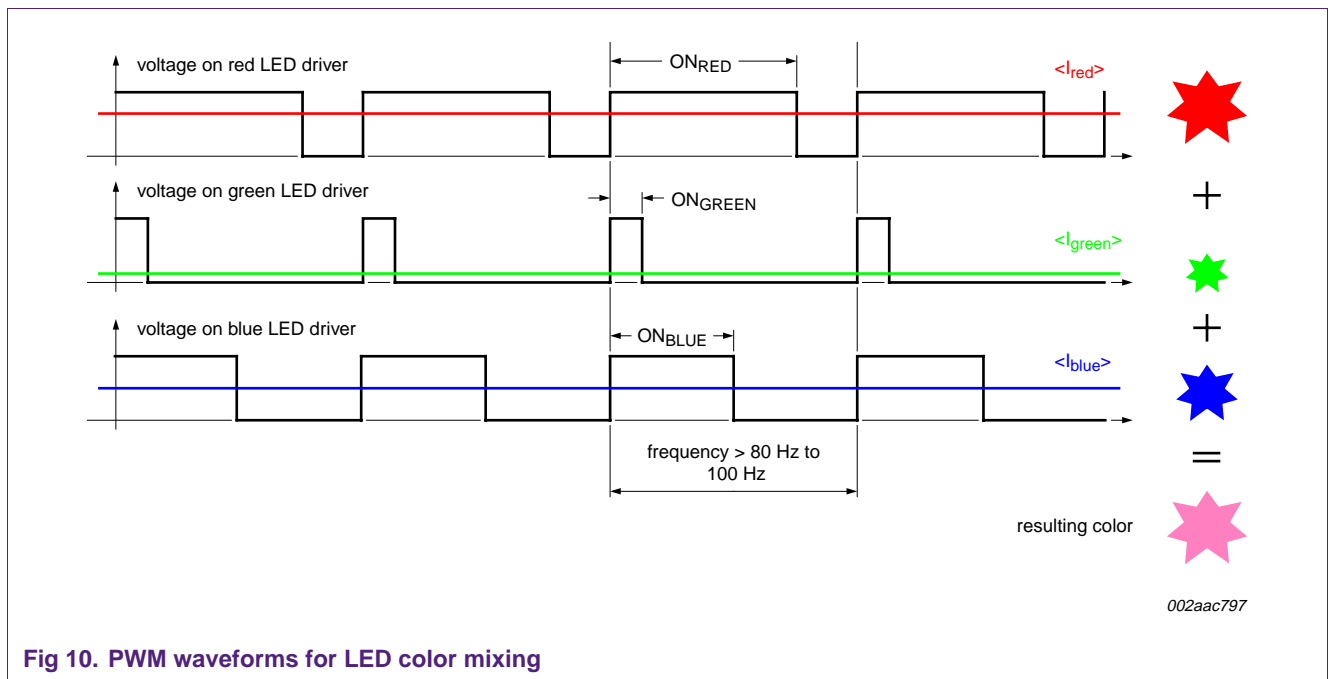

Fig 10. PWM waveforms for LED color mixing

Brightness for each primary color (desired amount of each primary color) is controlled with the duty cycle of PWMs. To perform color mixing the frequency of PWM should be high enough so that the human eye does not see the ON/OFF phases that could result in unwanted flicker.

### 4. NXP power solutions for LED supply

As mentioned earlier, a DC supply rail of 45 V or greater is needed to drive the LED strings used in the Light bars. This is best done using an offline power supply. NXP's highly efficient STARplug+ range of controller ICs for low-power switched mode power supplies (SMPs) are well-suited for this application. STARplug+ products operate directly from rectified universal mains supplies: 80 V to 276 V. Essentially turnkey solutions, they dramatically cut design-in time for new power supplies in many applications.

STARplug+ devices are manufactured using NXP's high-voltage EZ-HV process. This technology allows analog, digital and power circuitry to be implemented on the same chip. Combined with a low-voltage BiCMOS process, it enables low-power, low-cost and extremely compact solutions for power plugs and small supplies including power supply for LED light bars. All STARplug+ devices feature an integrated power switch, reducing the external component count and bill of materials.

Figure 11 shows one such power supply that provides 45 V for the LED light bar. The 120 V AC input voltage is rectified by a full bridge. A small filter or smoothing capacitor is used to hold the rectified voltage to approximately +170 V<sub>DC</sub>. The unregulated 170 V<sub>DC</sub> is connected to the input of the STARplug+ family switched mode controller chip that is configured for buck mode operation.

For more detailed information on NXP's power conversion solutions go to:  
[http://www.nxp.com/products/power\\_management/conversion/starplug/index.html](http://www.nxp.com/products/power_management/conversion/starplug/index.html)

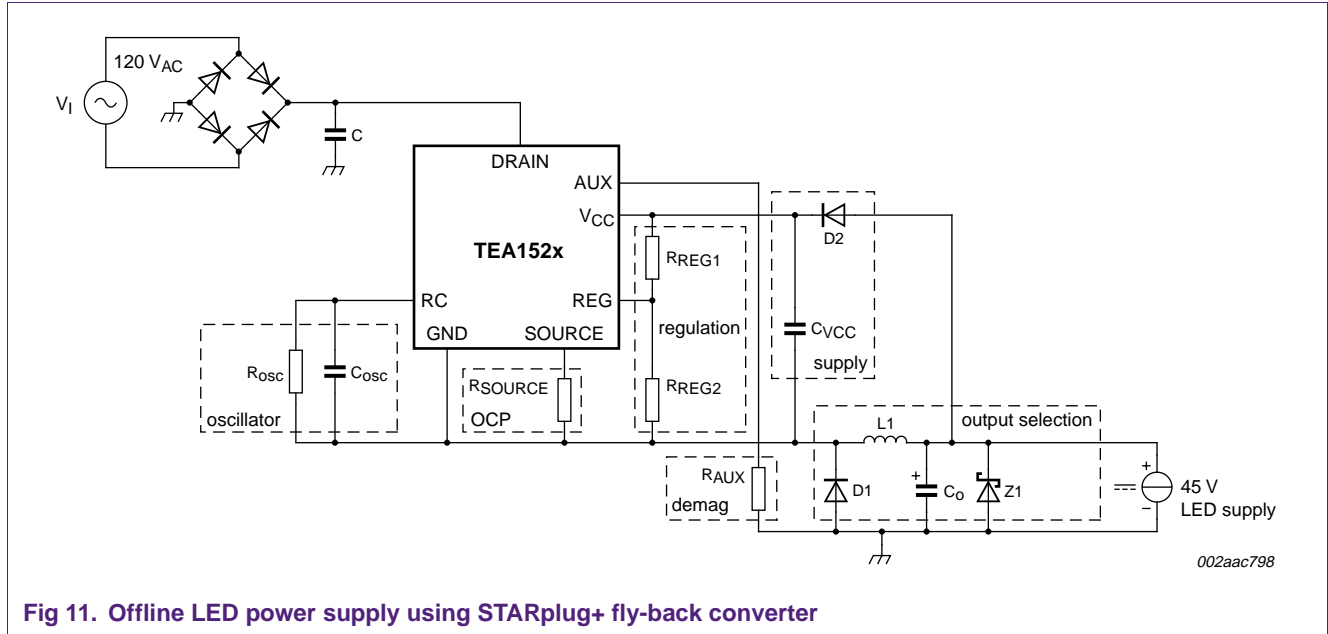

Fig 11. Offline LED power supply using STARplug+ fly-back converter

## 5. Summary

---

The PCA9633 LED controller can be used as a companion chip for providing a driver controller and color mixing capabilities for LED strings like the Avago ADJD-MJ00/ADJD-MJ10 RGB light bars. This application note outlined the capabilities of these devices and discussed how effective and programmable color mixing can be achieved with minimal software effort.

## 6. Additional information

---

Detailed information on PCA family of LED blinkers, dimmers, controllers and other I<sup>2</sup>C-bus products can be found at the NXP Semiconductors website:

[http://www.nxp.com/products/interface\\_control/i2c/](http://www.nxp.com/products/interface_control/i2c/)

For more detailed information on NXP Semiconductors power conversion solutions go to:

[http://www.nxp.com/products/power\\_management/conversion/starplug/index.html](http://www.nxp.com/products/power_management/conversion/starplug/index.html)

## 7. Abbreviations

---

**Table 2. Abbreviations**

Acronym	Description
BiCMOS	Bipolar Complementary Metal Oxide Semiconductor
CIE	Commission Internationale de l'Eclairage (International Commission on Illumination)
FET	Field-Effect Transistor
IC	Integrated Circuit
I <sup>2</sup> C-bus	Inter-Integrated Circuit bus
LED	Light Emitting Diode
PCB	Printed-Circuit Board
PWM	Pulse Width Modulator
RGB	Red/Green/Blue
SMPS	Switched Mode Power Supply

## 8. Legal information

---

### 8.1 Definitions

**Draft** — The document is a draft version only. The content is still under internal review and subject to formal approval, which may result in modifications or additions. NXP Semiconductors does not give any representations or warranties as to the accuracy or completeness of information included herein and shall have no liability for the consequences of use of such information.

### 8.2 Disclaimers

**General** — Information in this document is believed to be accurate and reliable. However, NXP Semiconductors does not give any representations or warranties, expressed or implied, as to the accuracy or completeness of such information and shall have no liability for the consequences of use of such information.

**Right to make changes** — NXP Semiconductors reserves the right to make changes to information published in this document, including without limitation specifications and product descriptions, at any time and without notice. This document supersedes and replaces all information supplied prior to the publication hereof.

**Suitability for use** — NXP Semiconductors products are not designed, authorized or warranted to be suitable for use in medical, military, aircraft, space or life support equipment, nor in applications where failure or malfunction of a NXP Semiconductors product can reasonably be expected to result in personal injury, death or severe property or environmental damage. NXP Semiconductors accepts no liability for inclusion and/or use of NXP Semiconductors products in such equipment or applications and therefore such inclusion and/or use is at the customer's own risk.

**Applications** — Applications that are described herein for any of these products are for illustrative purposes only. NXP Semiconductors makes no representation or warranty that such applications will be suitable for the specified use without further testing or modification.

### 8.3 Trademarks

Notice: All referenced brands, product names, service names and trademarks are the property of their respective owners.

**I<sup>2</sup>C-bus** — logo is a trademark of NXP B.V.

**STARplug+** — is a trademark of NXP B.V.

## 9. Contents

---

<b>1</b>	<b>Introduction</b> .....	<b>3</b>
<b>2</b>	<b>LED light bars</b> .....	<b>3</b>
2.1	Electrical configuration .....	3
2.2	Color configuration .....	4
2.3	Drive configuration .....	5
<b>3</b>	<b>The PCA9633 intelligent LED controller</b> .....	<b>6</b>
3.1	Programmable RGGB/RGBA controller .....	6
3.2	Functional description .....	7
3.3	Basic electrical configuration for using a PCA9633 .....	8
3.4	Driving light bars with a PCA9633 .....	9
3.5	Individual brightness control with group dimming/blinking with PCA9633 .....	11
3.6	Color mixing and control .....	12
<b>4</b>	<b>NXP power solutions for LED supply</b> .....	<b>13</b>
<b>5</b>	<b>Summary</b> .....	<b>14</b>
<b>6</b>	<b>Additional information</b> .....	<b>14</b>
<b>7</b>	<b>Abbreviations</b> .....	<b>14</b>
<b>8</b>	<b>Legal information</b> .....	<b>15</b>
8.1	Definitions .....	15
8.2	Disclaimers .....	15
8.3	Trademarks .....	15
<b>9</b>	<b>Contents</b> .....	<b>16</b>

---

Please be aware that important notices concerning this document and the product(s) described herein, have been included in section 'Legal information'.

---

© NXP B.V. 2007.

All rights reserved.

For more information, please visit: <http://www.nxp.com>

For sales office addresses, please send an email to: [salesaddresses@nxp.com](mailto:salesaddresses@nxp.com)

Date of release: 1 February 2007

Document identifier: AN10579\_1

founded by

**PHILIPS**