



# **Multimedia Applications Processors - Integrated Electronic Paper Display (EPD), High Performance, Arm® Cortex®-A8 Core**

## **i.MX508**

Last Updated: Jul 31, 2023

The i.MX508 processor is the first system-on-chip (SoC) designed specifically for eReaders that incorporates a high performance 800MHz Arm® Cortex®-A8 processor and an integrated hardware Electronic Paper Display (EPD) Controller certified by E Ink® to drive the latest and next generation Pearl™ panels. The i.MX508 enables reduced system cost, longer battery life and higher performance for faster page flips and a better reading experience.

The i.MX508 is supported by a companion NXP® power management IC, MMPF0100.

## i.MX508 Multimedia Applications Processor Block Diagram Block Diagram

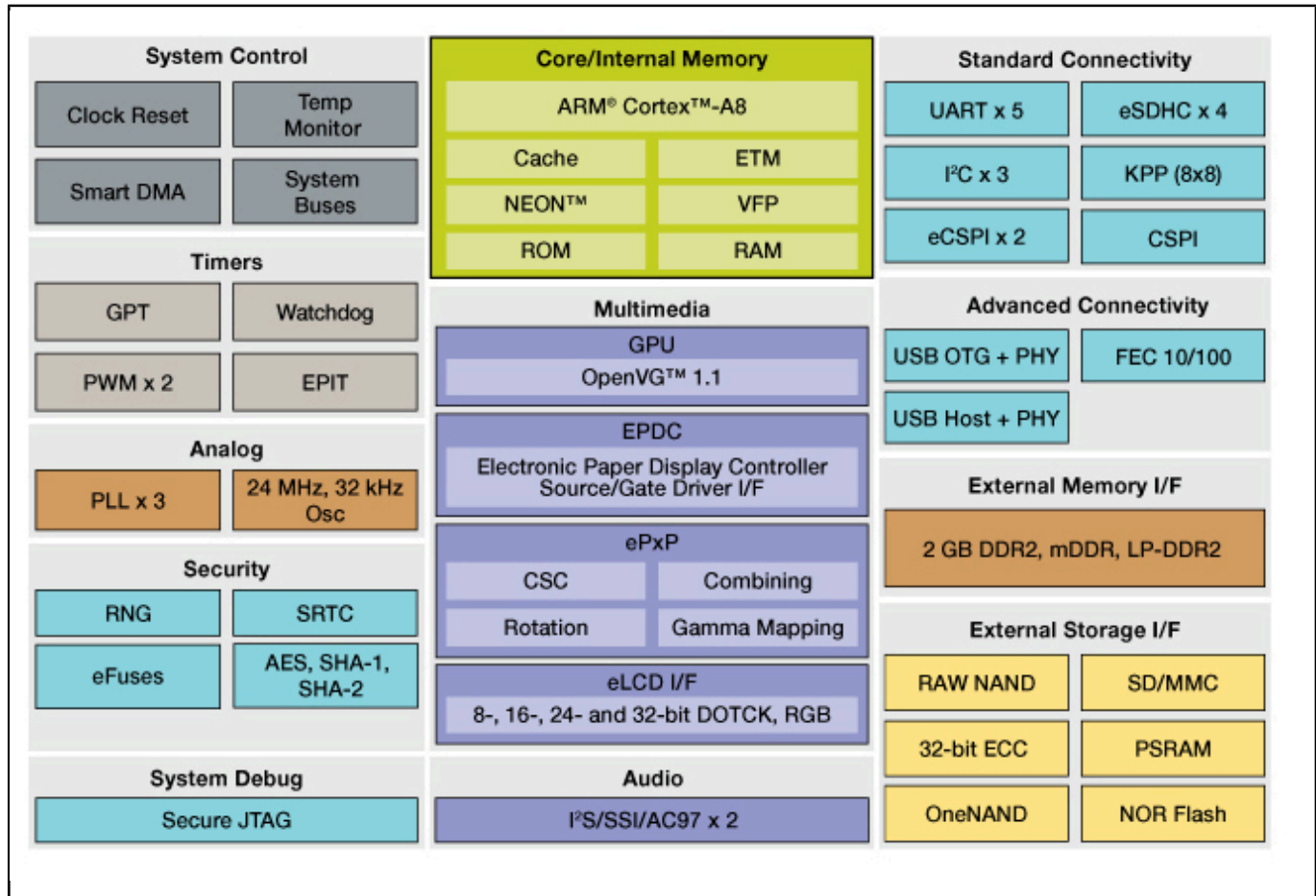

View additional information for [Multimedia Applications Processors - Integrated Electronic Paper Display \(EPD\), High Performance, Arm® Cortex®-A8 Core.](#)

Note: The information on this document is subject to change without notice.

[www.nxp.com](http://www.nxp.com)

NXP and the NXP logo are trademarks of NXP B.V. All other product or service names are the property of their respective owners. The related technology may be protected by any or all of patents, copyrights, designs and trade secrets. All rights reserved. © 2024 NXP B.V.