



High-Speed CAN/Dual-LIN Core System Basis Chip

UJA1078ATW

Last Updated: Jan 19, 2024

The UJA1078A core System Basis Chip (SBC) replaces the basic discrete components commonly found in Electronic Control Units (ECU) with an integrated High-Speed CAN transceiver and two LIN transceivers, combined with a 250 mA voltage regulator for supplying a microcontroller; extendable with external PNP transistor for active power distribution.

The UJA1078A supports the networking applications used to control power and sensor peripherals by using a High-Speed CAN as the main network interface and the LIN interfaces as local sub-busses.

The UJA1078A is designed to be used in combination with a microcontroller that incorporates a CAN controller. The SBC ensures that the microcontroller always starts up in a controlled manner.

UJA1078ATW Block Diagram Block Diagram

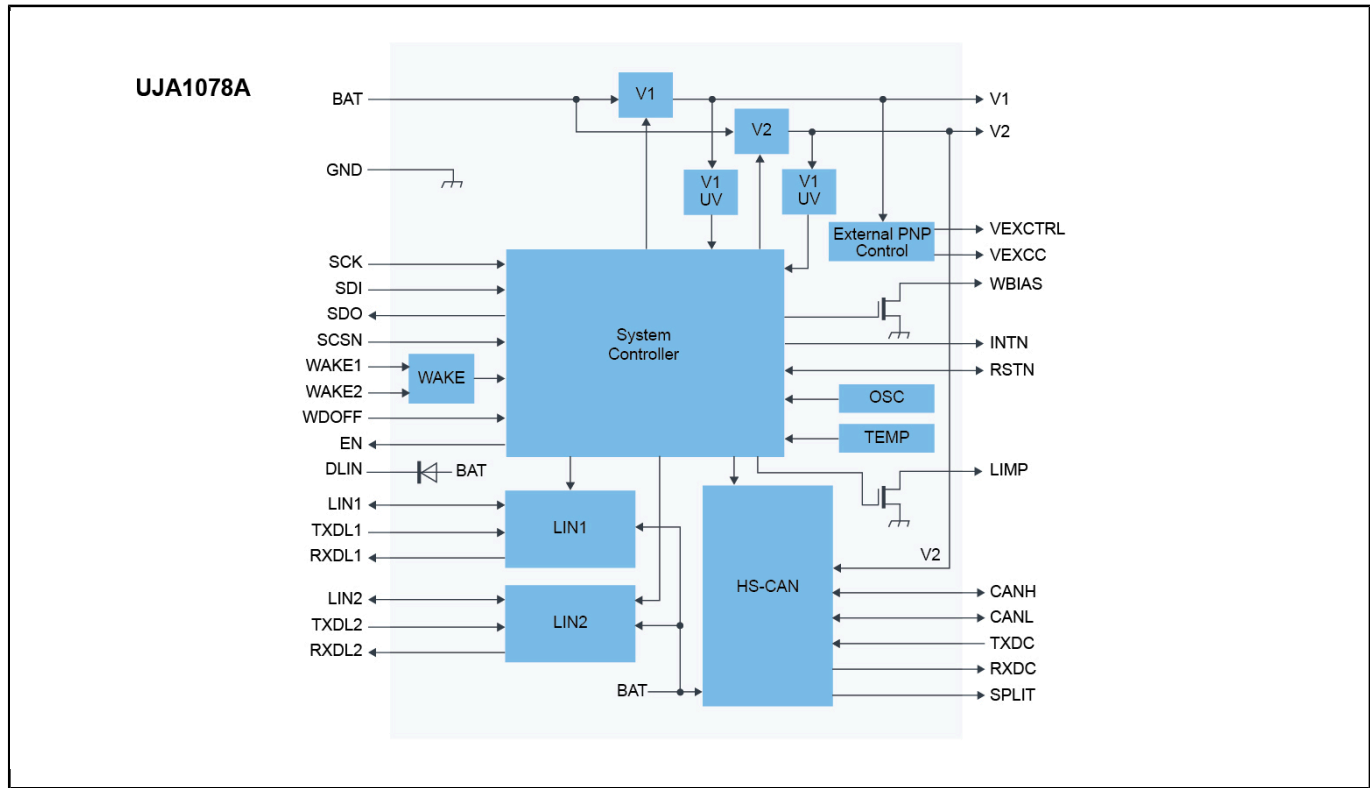

View additional information for [High-Speed CAN/Dual-LIN Core System Basis Chip](#).

Note: The information on this document is subject to change without notice.

www.nxp.com

NXP and the NXP logo are trademarks of NXP B.V. All other product or service names are the property of their respective owners. The related technology may be protected by any or all of patents, copyrights, designs and trade secrets. All rights reserved. © 2024 NXP B.V.