



# CAN SIC Evaluation Board

## UCANS32K1SIC

Last Updated: May 16, 2024

The UCANS32K1SIC is a CAN signal improvement capability (SIC) evaluation board designed for both automotive and industrial applications. CAN SIC enables more complex networks and CAN FD communication up to 8 Mbps by reducing the effects of signal ringing.

The UCANS32K1SIC provides two CAN SIC interfaces and is based on the 32-bit Arm® Cortex®M4 based S32K1 microcontroller family with access to ports on the processor. Also, the UCANS32K1SIC features EdgeLock® SE050 secure element for authentication and encryption development.

# UCANS32K1SIC Block Diagram Block Diagram

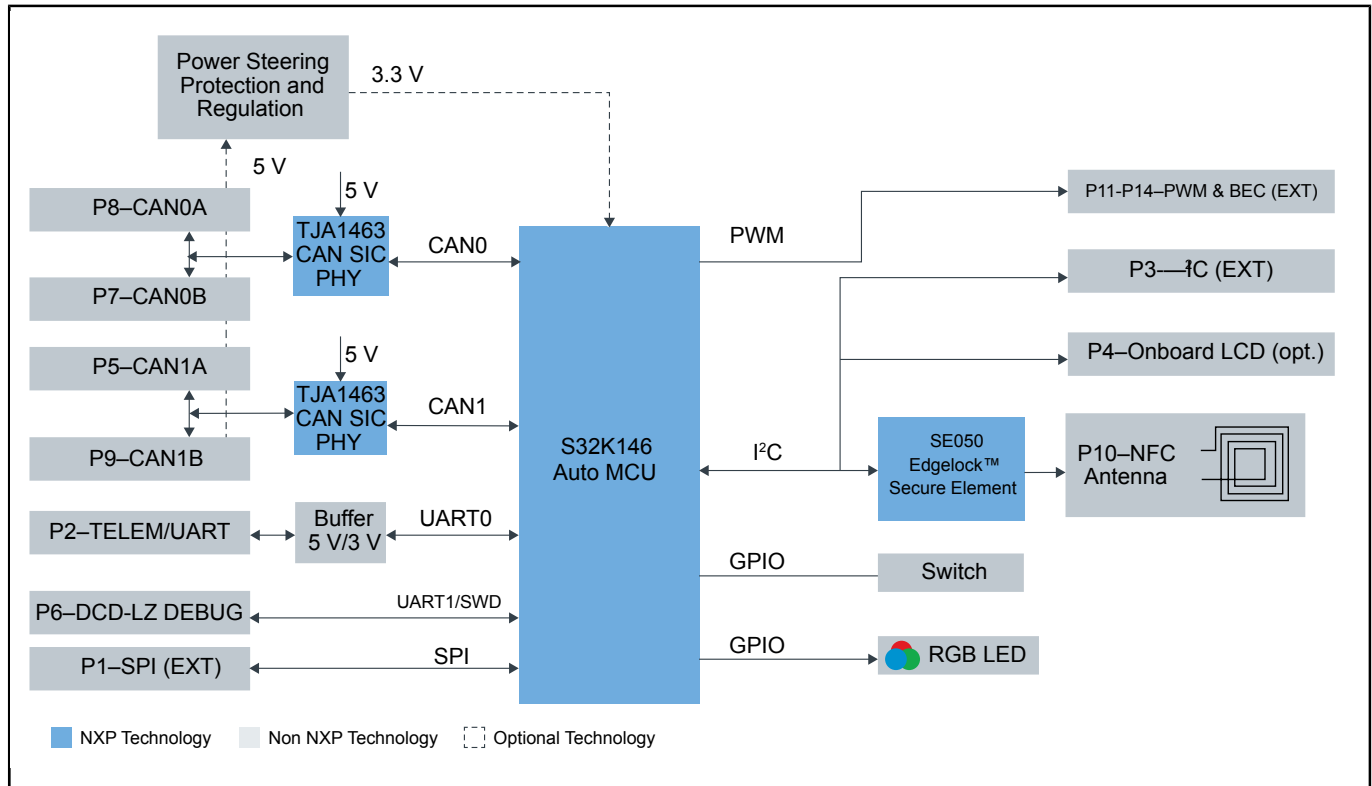

View additional information for [CAN SIC Evaluation Board](#).

**Note:** The information on this document is subject to change without notice.

**www.nxp.com**

NXP and the NXP logo are trademarks of NXP B.V. All other product or service names are the property of their respective owners. The related technology may be protected by any or all of patents, copyrights, designs and trade secrets. All rights reserved. © 2024 NXP B.V.