



Two-Phase Power Meter Reference Design

TWO-PHASE-POWER-METER

Last Updated: May 1, 2023

With the growing consumption of energy worldwide, particularly in the residential market, utility providers need increasingly accurate and cost-effective energy metering solutions. The Kinetis® M series two-phase electricity meter reference design addresses these accuracy and cost needs by providing a high-performance analog front end combined with an embedded programmable gain amplifier to increase the accuracy of energy measurement.

Two Phase Meter Block Diagram

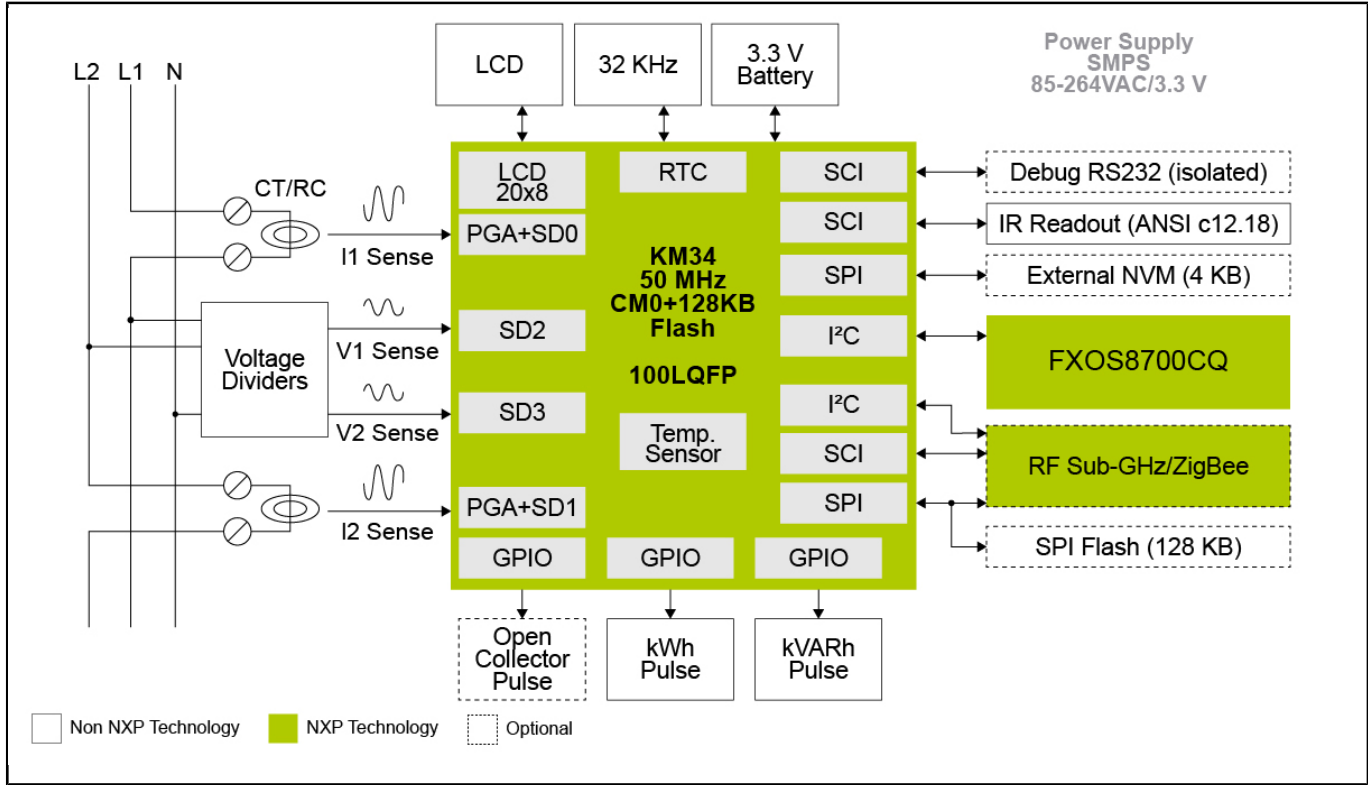

View additional information for [Two-Phase Power Meter Reference Design](#).

Note: The information on this document is subject to change without notice.

www.nxp.com

NXP and the NXP logo are trademarks of NXP B.V. All other product or service names are the property of their respective owners. The related technology may be protected by any or all of patents, copyrights, designs and trade secrets. All rights reserved. © 2024 NXP B.V.