



# Secure HS-CAN Transceiver with Sleep Mode

## TJA1153

Last Updated: Aug 3, 2023

NXP's new secure CAN transceiver TJA1153A provides a seamless and very cost-effective solution for securing classical CAN and CAN FD communication without cryptography. The TJA1153A belongs to a new generation of automotive high-speed CAN/CAN FD transceivers, offering security functions. It provides an interface between a classical CAN or CAN FD protocol controller and the physical two-wire CAN bus. As long as no security incidents have been detected, the TJA1153A behaves like a standard CAN transceiver with Sleep mode.

The security incidents that can be detected and contained are:

- Flooding the bus from the local node
- Transmitting a CAN message with an identifier that has not been assigned to the local node for transmission
- Receiving a CAN message from a remote host with an identifier that is identical to one uniquely assigned to this local node
- Tampered messages

## TJA1153 Application Block Diagram Block Diagram

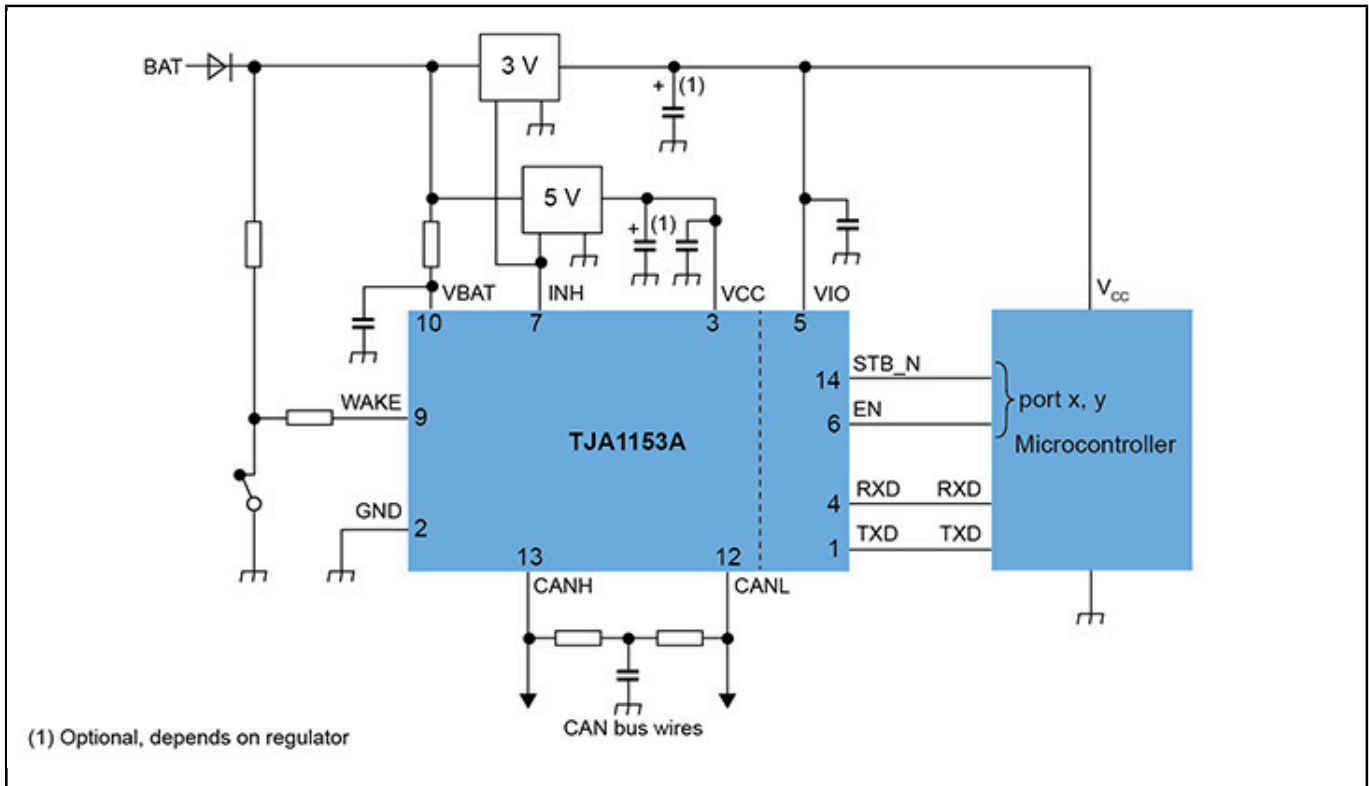

View additional information for [Secure HS-CAN Transceiver with Sleep Mode](#).

Note: The information on this document is subject to change without notice.

[www.nxp.com](http://www.nxp.com)

NXP and the NXP logo are trademarks of NXP B.V. All other product or service names are the property of their respective owners. The related technology may be protected by any or all of patents, copyrights, designs and trade secrets. All rights reserved. © 2024 NXP B.V.