



# FlexRay Active Star Coupler – 2 Branch

## TJA1086G

Last Updated: Jul 20, 2023

The TJA1086G is a FlexRay™ active star coupler that connects two branches of a FlexRay network. The TJA1086G is compliant with the FlexRay electrical physical layer specification V3.0.1/ISO17458-4.

- Several TJA1085G and TJA1086G devices can be connected via their TRXD0/1 interfaces to increase the number of branches in the network
- A dedicated Communication Controller interface allows for integration into an ECU
- Supports low-power management by offering bus wake-up capability along with battery supply and voltage regulator control
- Meets industry standards for EMC/ESD performance and provides enhanced bus error detection, low current consumption and unmatched asymmetric delay performance

# TJA1086G Block Diagram Block Diagram

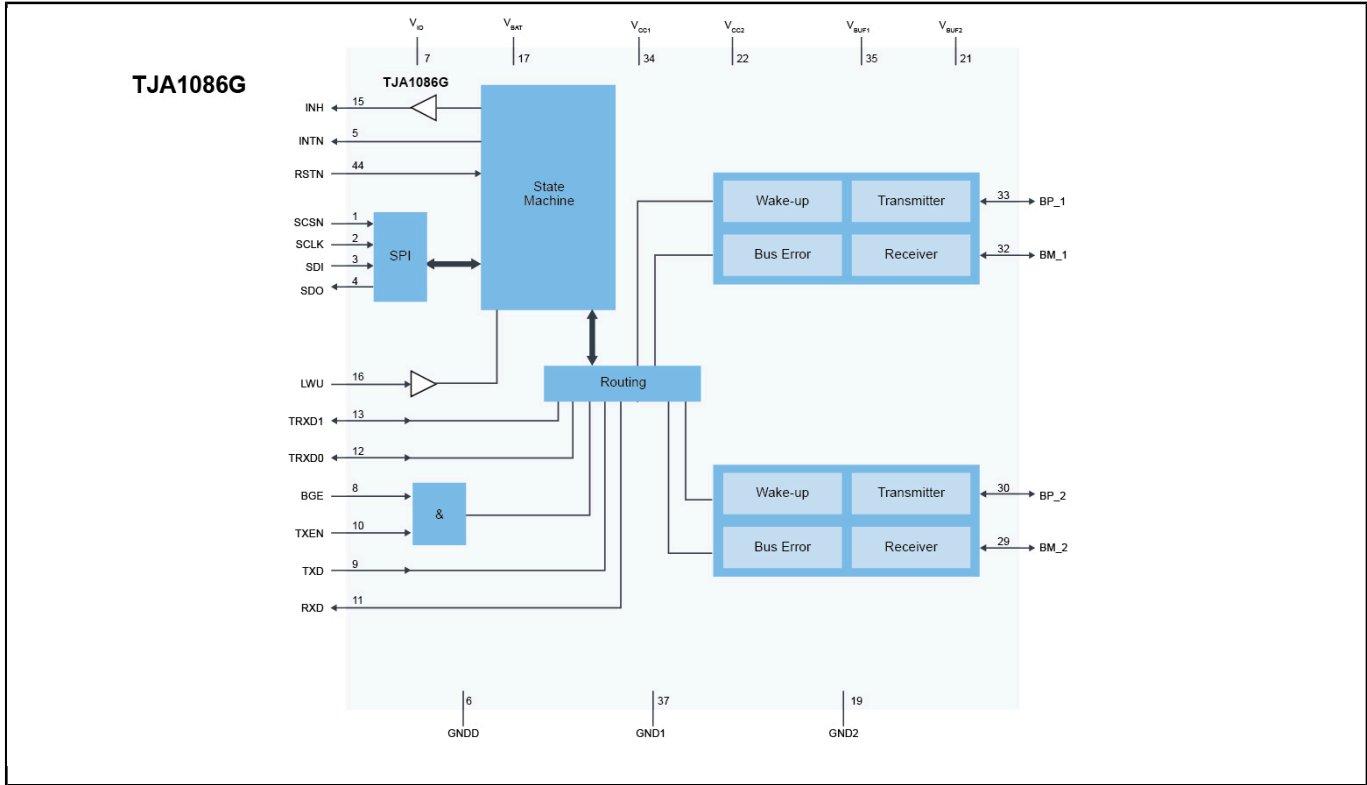

Active star coupler that connects two branches of a FlexRay network Block Diagram

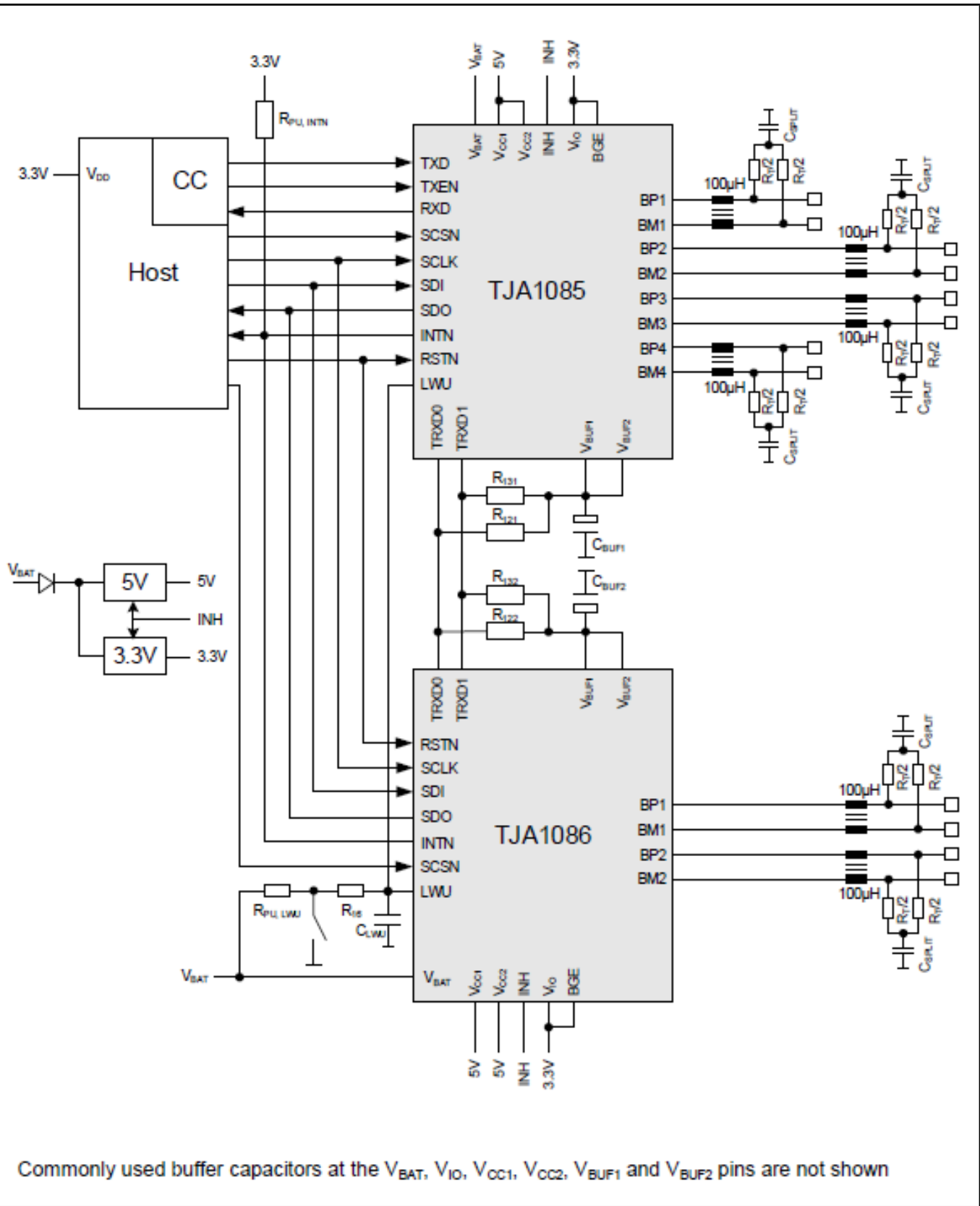

View additional information for [FlexRay Active Star Coupler – 2 Branch](#).

Note: The information on this document is subject to change without notice.

**[www.nxp.com](http://www.nxp.com)**

NXP and the NXP logo are trademarks of NXP B.V. All other product or service names are the property of their respective owners. The related technology may be protected by any or all of patents, copyrights, designs and trade secrets. All rights reserved. © 2024 NXP B.V.