



FlexRay Transceiver

TJA1080ATS

Last Updated: Jul 20, 2023

The TJA1080A is a FlexRay transceiver that is fully compliant with the FlexRay electrical physical layer specification V2.1 Rev. A. In addition, it incorporates features and parameters included in V3.0.1. It is primarily intended for communication systems from 1 Mbit/s to 10 Mbit/s, and provides an advanced interface between the protocol controller and the physical bus in a FlexRay network.

The TJA1080A can be configured to be used as an active star transceiver or as a node transceiver.

The TJA1080A provides differential transmit capability to the network and differential receive capability to the FlexRay controller. It offers excellent EMC performance as well as high ESD protection.

The TJA1080A actively monitors the system performance using dedicated error and status information (readable by any microcontroller), as well as internal voltage and temperature monitoring.

The TJA1080A supports the mode control as used in NXP Semiconductors TJA1054 and TJA1041 CAN transceivers.

The TJA1080A is the next step up from the TJA1080 FlexRay transceiver. Being fully pin compatible and offering the same excellent ESD protection, the TJA1080A also features:

- Improved power-on reset concept
- Improved ElectroMagnetic Emission (EME)
- Support of 60 ns minimum bit time
- Improved bus error detection functionality

This makes the TJA1080A an excellent choice in any kind of FlexRay node.

TJA1080A Block Diagram Block Diagram

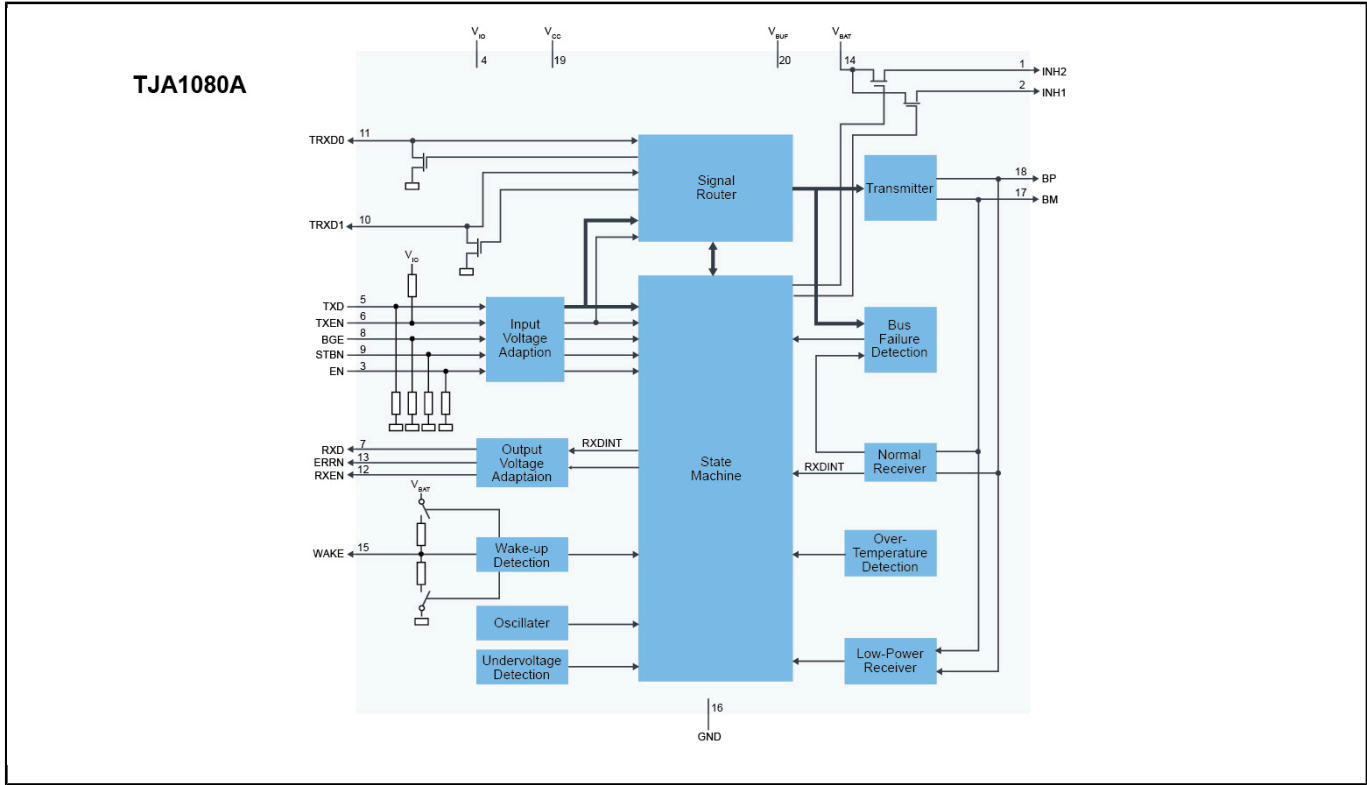

View additional information for [FlexRay Transceiver](#).

Note: The information on this document is subject to change without notice.

www.nxp.com

NXP and the NXP logo are trademarks of NXP B.V. All other product or service names are the property of their respective owners. The related technology may be protected by any or all of patents, copyrights, designs and trade secrets. All rights reserved. © 2024 NXP B.V.