



# High-Speed CAN Transceiver with Standby Mode

## TJA1049

Last Updated: Apr 20, 2023

For security on TJA1042, TJA1044, TJA1049, go to Secure CAN TJA1152, for higher data rates on these devices, go to CAN SIC TJA1462.

The TJA1049 high-speed CAN transceiver provides an interface between a Controller Area Network (CAN) protocol controller and the physical two-wire CAN bus. The transceiver is designed for high-speed CAN applications in the automotive industry, supplying the differential transmit and receive capability to (a microcontroller with) a CAN protocol controller.

The TJA1049 belongs to the third generation of high-speed CAN transceivers from NXP Semiconductors, offering significant improvements over first- and second-generation devices such as the TJA1040. It offers improved ElectroMagnetic Compatibility (EMC) and ElectroStatic Discharge (ESD) performance, and also features:

- Ideal passive behavior to the CAN bus when the supply voltage is off
- A very low-current Standby mode with bus wake-up capability
- TJA1049T/3 and TJA1049TK/3 can be interfaced directly to microcontrollers with supply voltages from 3 V to 5 V

The TJA1049 implements the CAN physical layer as defined in the current ISO11898 standard (ISO11898-2:2003, ISO11898-5:2007 and the pending updated version of ISO 11898-2:2016). Pending the release of ISO11898-2:2016 including CAN FD and SAE J2284-4/5, additional timing parameters defining loop delay symmetry are specified. This implementation enables reliable communication in the CAN FD fast phase at data rates up to 5 Mbit/s.

These features make the TJA1049 an excellent choice for all types of HS-CAN networks, in nodes that require a low-power mode with wake-up capability via the CAN bus.

# TJA1049 Block Diagram Block Diagram

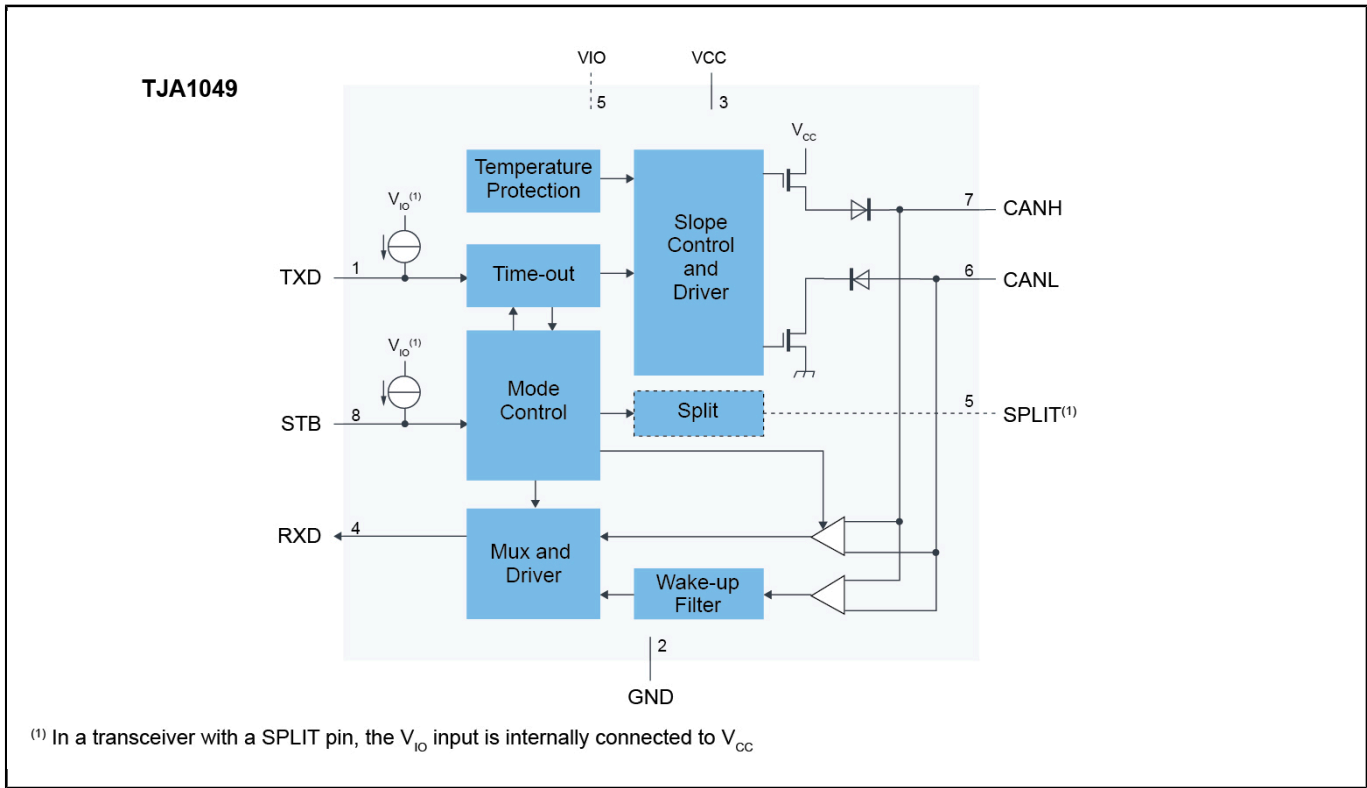

View additional information for [High-Speed CAN Transceiver with Standby Mode](#).

**Note:** The information on this document is subject to change without notice.

**www.nxp.com**

NXP and the NXP logo are trademarks of NXP B.V. All other product or service names are the property of their respective owners. The related technology may be protected by any or all of patents, copyrights, designs and trade secrets. All rights reserved. © 2024 NXP B.V.