



VeLIO Certified, Dual High-Speed CAN Transceivers with Standby Mode for Automotive Applications

TJA1046V

Last Updated: Jun 24, 2026

The TJA1046V is a dual high-speed CAN transceiver that provides two interfaces between a Controller Area Network (CAN) protocol controller and the physical two-wire CAN-bus. It is composed of two fully independent TJA1044V transceivers.

The transceivers are designed for high-speed CAN applications in the automotive industry, providing the differential transmit and receive capability to (a microcontroller with) a CAN protocol controller.

The TJA1046V guarantees robust communication at data rates up to 5 Mbit/s as used in, for example, CAN FD networks. The TJA1046V offers a feature set optimized for 12 V automotive applications and excellent ElectroMagnetic Compatibility (EMC) performance.

TJA1046V Block Diagram Block Diagram

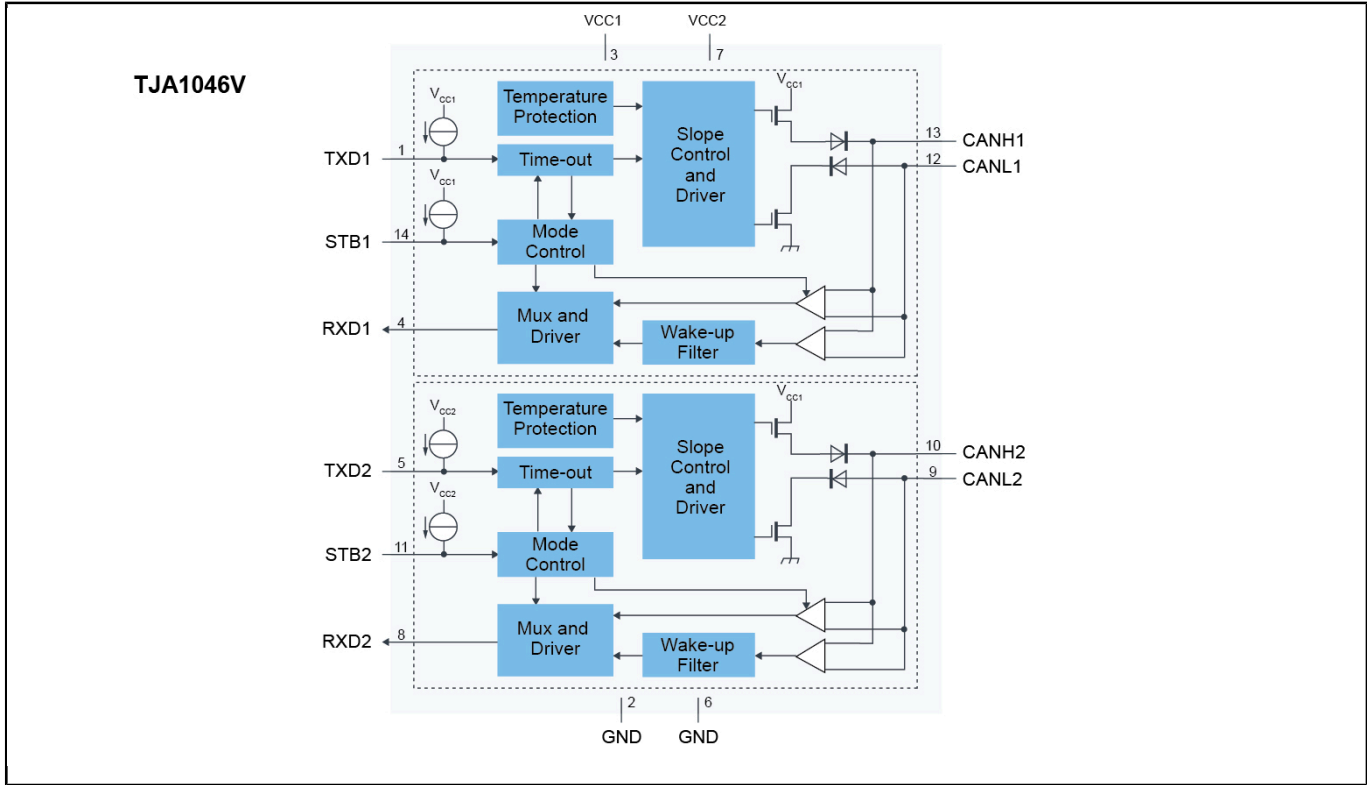

View additional information for [VeLIO Certified, Dual High-Speed CAN Transceivers with Standby Mode for Automotive Applications](#).

Note: The information on this document is subject to change without notice.

www.nxp.com

NXP and the NXP logo are trademarks of NXP B.V. All other product or service names are the property of their respective owners. The related technology may be protected by any or all of patents, copyrights, designs and trade secrets. All rights reserved. © 2026 NXP B.V.