



# Dual High-Speed CAN Transceiver with Standby Mode

## TJA1046

Last Updated: Jul 8, 2026

The TJA1046 is a dual high-speed CAN transceiver that provides two interfaces between a Controller Area Network (CAN) protocol controller and the physical two-wire CAN-bus. It is composed of two fully independent TJA1044GT transceivers. The transceivers are designed for high-speed CAN applications in the automotive industry, providing the differential transmit and receive capability to (a microcontroller with) a CAN protocol controller. The TJA1046 guarantees robust communication at data rates up to 5 Mbit/s as used in, for example, CAN FD networks.

The TJA1046 offers a feature set optimized for 12 V automotive applications and excellent ElectroMagnetic Compatibility (EMC) performance.

Additionally, the TJA1046 features:

- Ideal passive behavior to the CAN-bus when the supply voltage is off
- A very low-current Standby mode with bus wake-up capability
- Excellent EMC performance at speeds up to 500 kbit/s, even without a common mode choke

The HVSON package allows for more than 70 % PCB space saving compared with traditional SO packages. These features make the TJA1046 an excellent choice for networks containing more than one HS-CAN interface requiring a low-power mode with wake-up capability via the CAN-bus, especially for body and gateway control units.

The TJA1046 implements the CAN physical layer as defined in the current ISO11898 standard (ISO11898-2: 2003, ISO11898-5: 2007 and the pending updated version of ISO 11898-2:2016). Pending the release of ISO11898-2:2016 including CAN FD and SAE-J2284-4/5, additional timing parameters defining loop delay symmetry are specified. This implementation enables reliable communication in the CAN FD fast phase at data rates up to 5 Mbit/s.

# TJA1046V Block Diagram

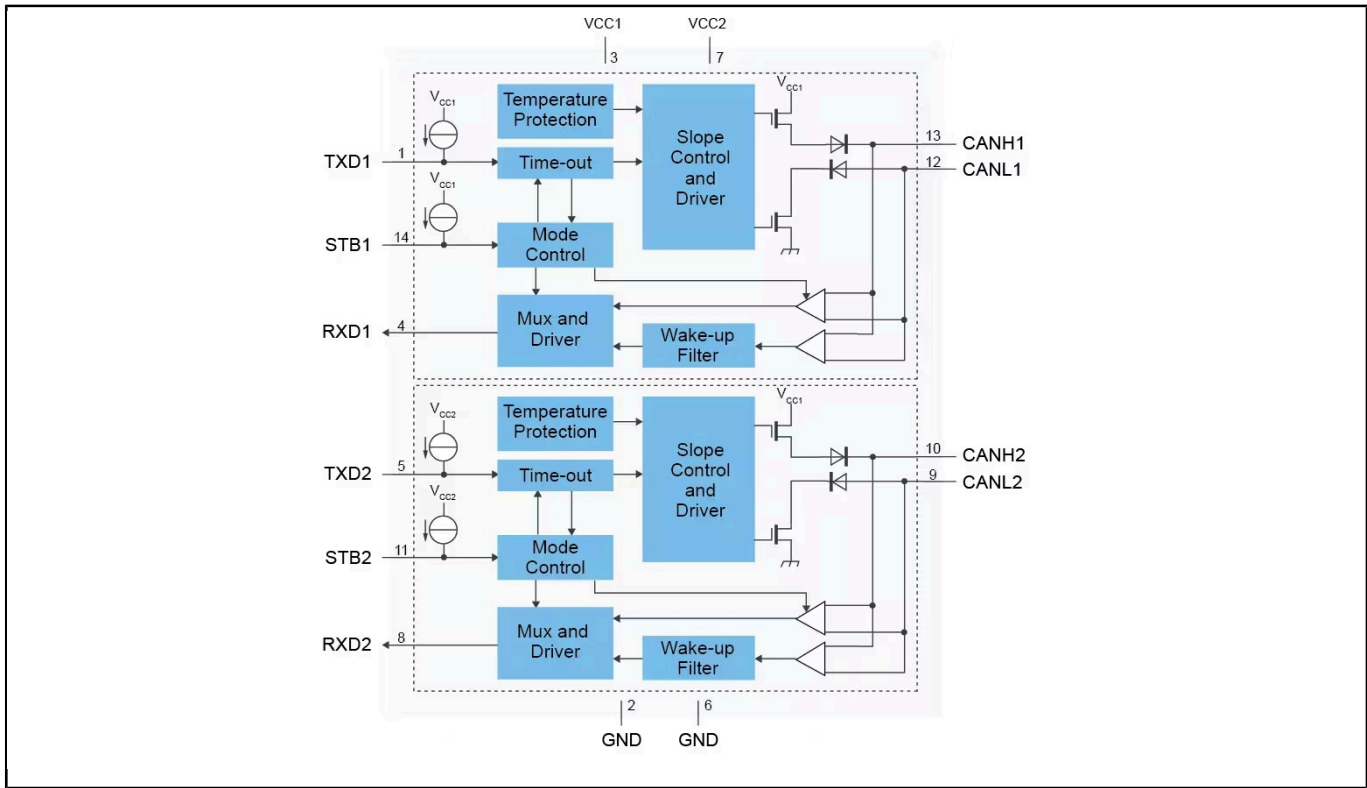

View additional information for [Dual High-Speed CAN Transceiver with Standby Mode](#).

**Note:** The information on this document is subject to change without notice.

**www.nxp.com**

NXP and the NXP logo are trademarks of NXP B.V. All other product or service names are the property of their respective owners. The related technology may be protected by any or all of patents, copyrights, designs and trade secrets. All rights reserved. © 2026 NXP B.V.