



KV Series 3-Phase AC Induction Motor Control

THREE-PHASE-AC-INDUCTION

Last Updated: May 1, 2023

The 3-phase AC induction motor (ACIM) control reference design is based on V series MCUs and provides an example for 3-phase sensorless ACIM control solutions. The reference solution features field oriented vector control (FOC) of rotor speed without any need for a speed or position sensor, improving reliability and lowering final design cost.

AC Induction Motor Block Diagram

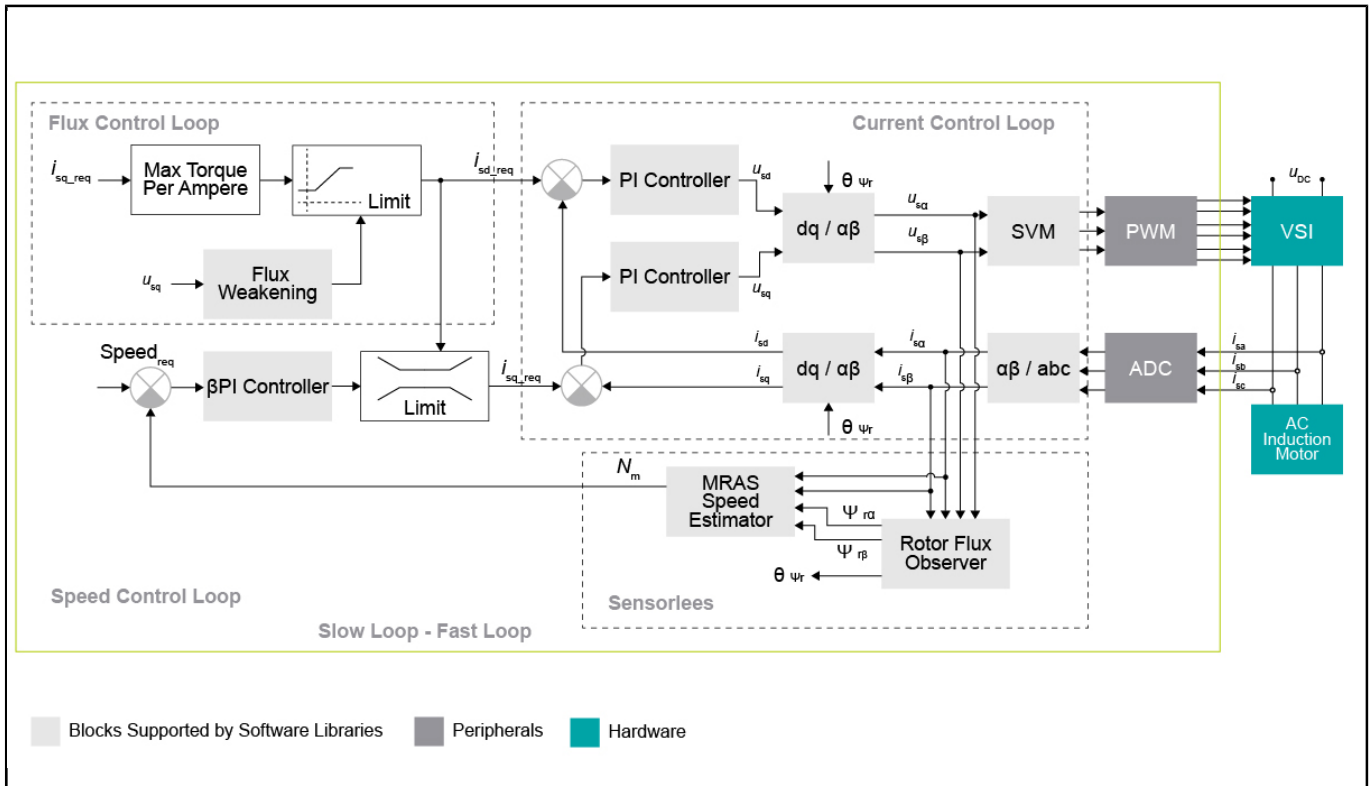

View additional information for [KV Series 3-Phase AC Induction Motor Control](#).

Note: The information on this document is subject to change without notice.

www.nxp.com

NXP and the NXP logo are trademarks of NXP B.V. All other product or service names are the property of their respective owners. The related technology may be protected by any or all of patents, copyrights, designs and trade secrets. All rights reserved. © 2024 NXP B.V.