



GreenChip Dual LLC SR Switching Controller

TEA2095

Last Updated: Aug 3, 2023

The TEA2095T/TE is a high performance synchronous rectifier (SR) controller IC for switch mode power supplies.

This SR controller incorporates an adaptive gate drive method to save the maximum amount of energy at any load. To increase efficiency, the TEA2095T/TE can operate at 90 μ A with a -25 mV regulation level, which optimizes functionality for use with low-ohmic MOSFETs.

TEA2095T/TE's undervoltage lockout (UVLO) protection allows devices to remain fully functional when supply voltage is below the minimum operating voltage and ensures the device stays off when voltage is below the UVLO threshold. This feature enhances overall system performance and increases efficiency.

Our product has two driver stages to drive SR MOSFETs, which rectify the outputs of the central tap secondary transformer windings. The two gate driver stages operate independently and come with differential inputs that sense the SR MOSFET's drain and source voltages.

The TEA2095T/TE is optimally used in resonant power supplies for servers, PCs, TVs, adapters, and other switch mode power supplies.

TEA2095 Block diagram Block Diagram

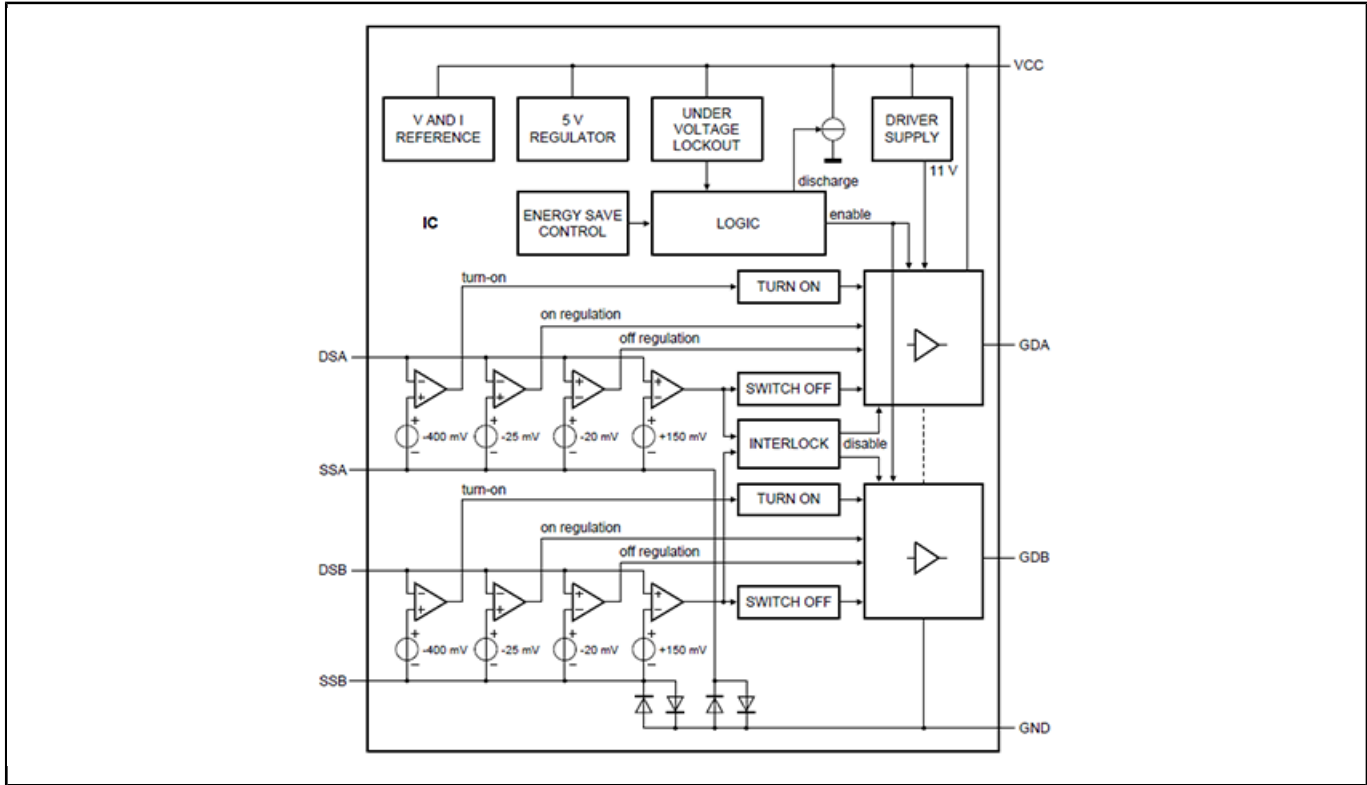

View additional information for [GreenChip Dual LLC SR Switching Controller](#).

Note: The information on this document is subject to change without notice.

www.nxp.com

NXP and the NXP logo are trademarks of NXP B.V. All other product or service names are the property of their respective owners. The related technology may be protected by any or all of patents, copyrights, designs and trade secrets. All rights reserved. © 2024 NXP B.V.