



Dual Synchronous Rectification Controller Suitable for Both High-Side and Low-Side Control

TEA1795T

Last Updated: Apr 11, 2024

The TEA1795T is a member of the new generation of Synchronous Rectifier (SR) controller ICs for switched mode power supplies. Its high level of integration enables the design of a cost-effective power supply with a minimum number of external components. The TEA1795T is a dedicated controller IC for synchronous rectification on the secondary side of resonant converters. It has two driver stages for driving the SR MOSFETs, which are rectifying the outputs of the central tap secondary transformer windings. The two gate driver stages have their own sensing inputs and operate independently of each other. The TEA1795T is fabricated in a Silicon On Insulator (SOI) process.

TEA1795T Block Diagram Block Diagram

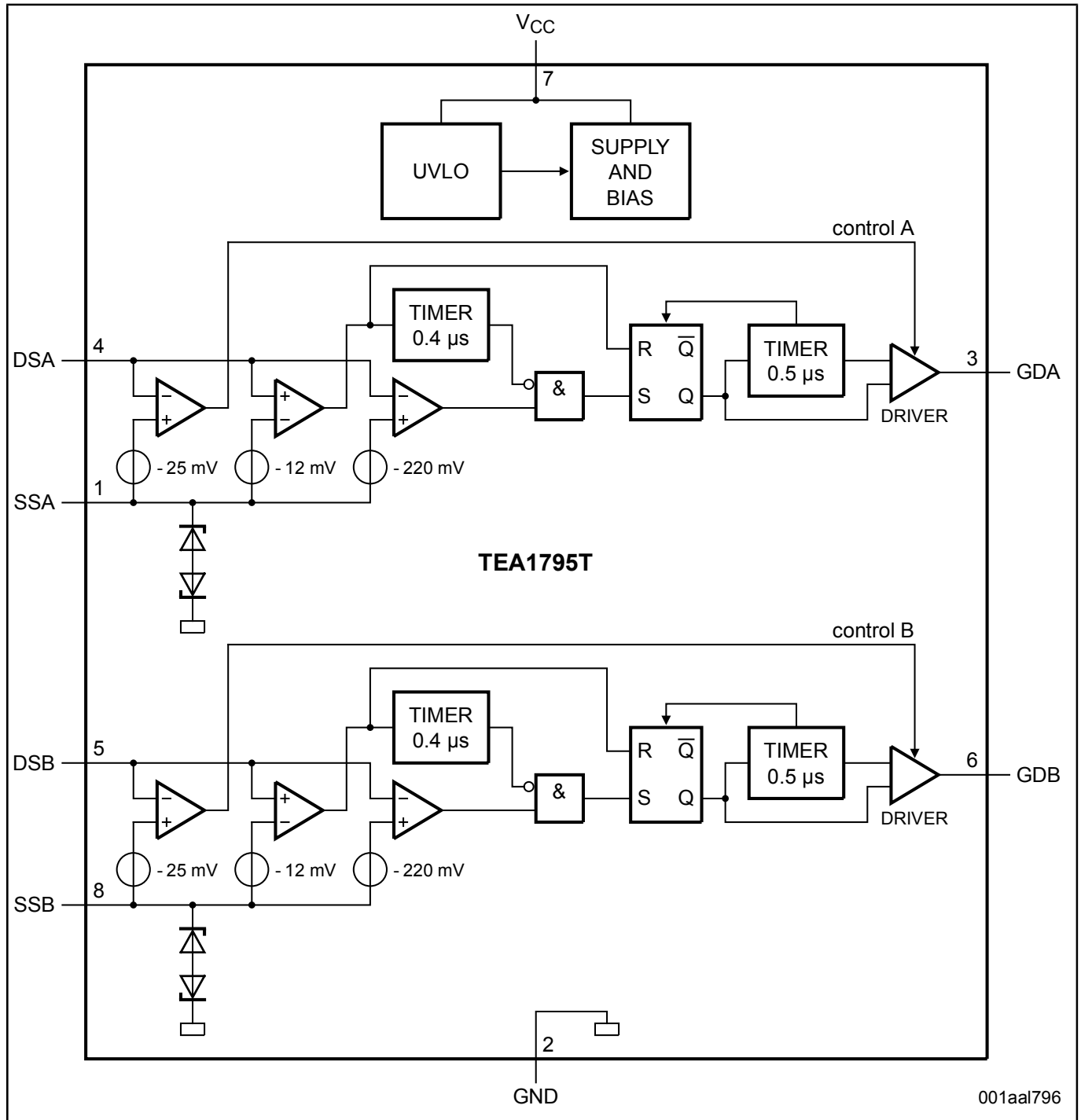

Block diagram TEA1795T Block Diagram

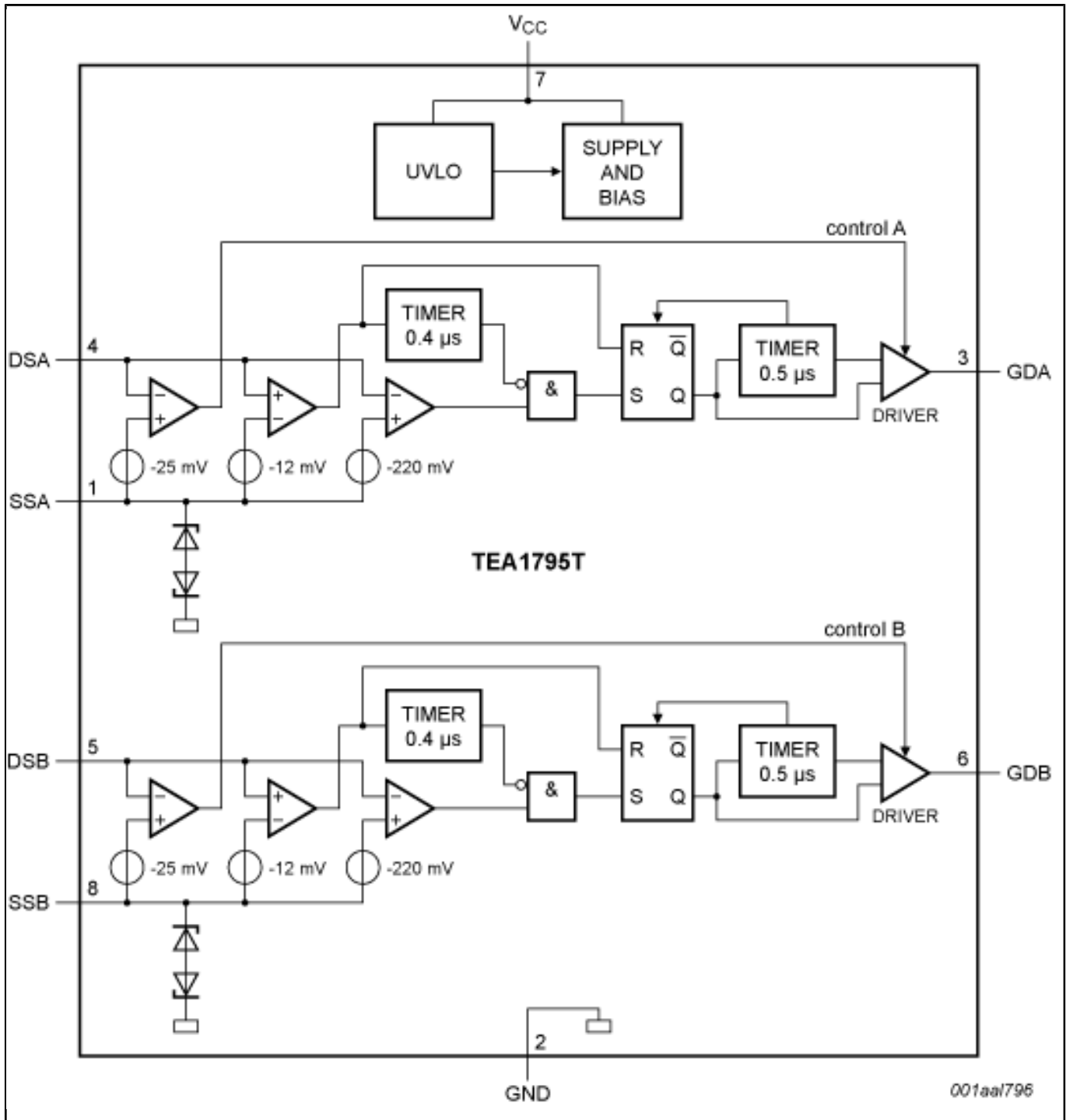

View additional information for [Dual Synchronous Rectification Controller Suitable for Both High-Side and Low-Side Control](#).

Note: The information on this document is subject to change without notice.

www.nxp.com

NXP and the NXP logo are trademarks of NXP B.V. All other product or service names are the property of their respective owners. The related technology may be protected by any or all of patents, copyrights, designs and trade secrets. All rights reserved. © 2024 NXP B.V.