



# 1.8 V Single UART, 20 Mbit/s (max.) with 128-Byte FIFOs, Infrared (IrDA), and XScale VLIO Bus Interface

## SC16C850SVIBS

### アーカイブス

このページには、製造中止（生産終了）となった製品の情報が記載されています。本ページに記載されている仕様および情報は、過去の参考情報です。

Last Updated: Nov 9, 2023

The SC16C850SV is a 1.8 V, low power single channel Universal Asynchronous Receiver and Transmitter (UART) used for serial data communications. Its principal function is to convert parallel data into serial data and vice versa. The UART can handle serial data rates up to 20 Mbit/s (4× sampling rate). SC16C850SV can be programmed to operate in extended mode where additional advanced UART features are available. The SC16C850SV family UART provides enhanced UART functions with 128-byte FIFOs, modem control interface and IrDA encoder/decoder. On-board status registers provide the user with error indications and operational status. System interrupts and modem control features may be tailored by software to meet specific user requirements. An internal loopback capability allows on-board diagnostics. Independent programmable baud rate generators are provided to select transmit and receive baud rates.

The SC16C850SV with Intel XScale processor VLIO interface operates at 1.8 V and is available in the HVQFN32 package.

# SC16C850SV Block Diagram

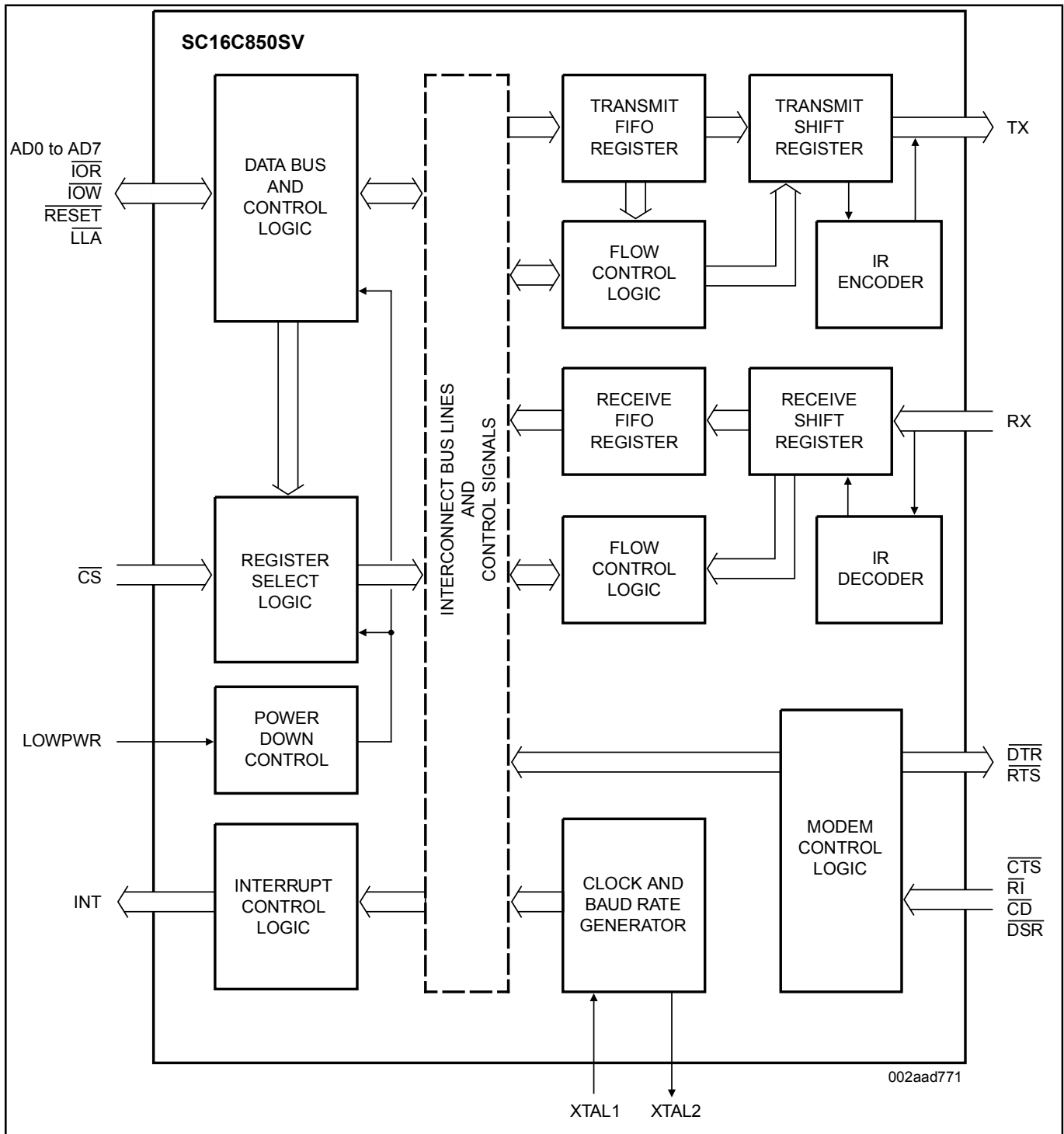

View additional information for [1.8 V Single UART, 20 Mbit/s \(max.\) with 128-Byte FIFOs, Infrared \(IrDA\), and XScale VLIO Bus Interface](#).

**Note:** The information on this document is subject to change without notice.

**[www.nxp.com](http://www.nxp.com)**

NXP and the NXP logo are trademarks of NXP B.V. All other product or service names are the property of their respective owners. The related technology may be protected by any or all of patents, copyrights, designs and trade secrets. All rights reserved. © 2024 NXP B.V.