



1.8 V Single UART, 16 Mode or 68 Mode Parallel Bus Interface

SC16C850L

Archived

このページには、製造中止（生産終了）となった製品の情報が記載されています。本ページに記載されている仕様および情報は、過去の参考情報です。

Last Updated: Aug 16, 2023

The SC16C850L is a 1.8 V, low power, single channel Universal Asynchronous Receiver and Transmitter (UART) used for serial data communications. Its principal function is to convert parallel data into serial data and vice versa. The UART can handle serial data rates up to 5 Mbit/s. The SC16C850L is functionally (software) compatible with the SC16C650B. SC16C850L can be programmed to operate in extended mode (see Section 6.2) where additional advanced UART features are available. The SC16C850L UART provides enhanced UART functions with 128-byte FIFOs, modem control interface and IrDA encoder/decoder. On-board status registers provide the user with error indications and operational status. System interrupts and modem control features may be tailored by software to meet specific user requirements. An internal loopback capability allows on-board diagnostics.

The SC16C850LIBS with Intel (16 mode) or Motorola (68 mode) bus host interface operates at 1.8 V and is available in a very small (Micro-UART) HVQFN32 package.

The SC16C850LIET with Intel (16 mode) bus host interface operates at 1.8 V and is available in a very small TFBGA36 package.

SC16C850LIB, SC16C850LIBS, SC16C850LIET Block Diagram

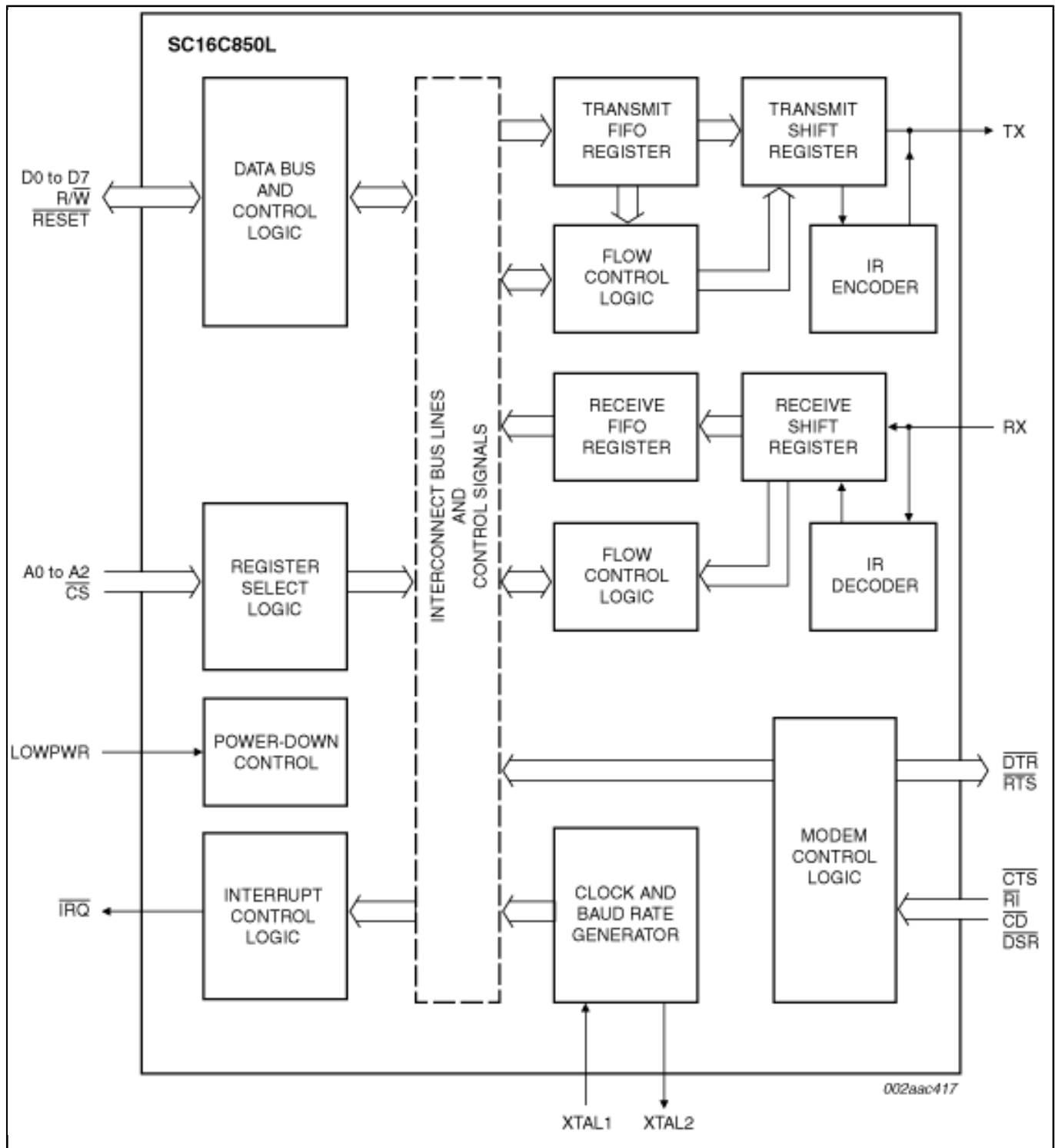

SC16C850LIB, SC16C850LIBS, SC16C850LIET Block Diagram

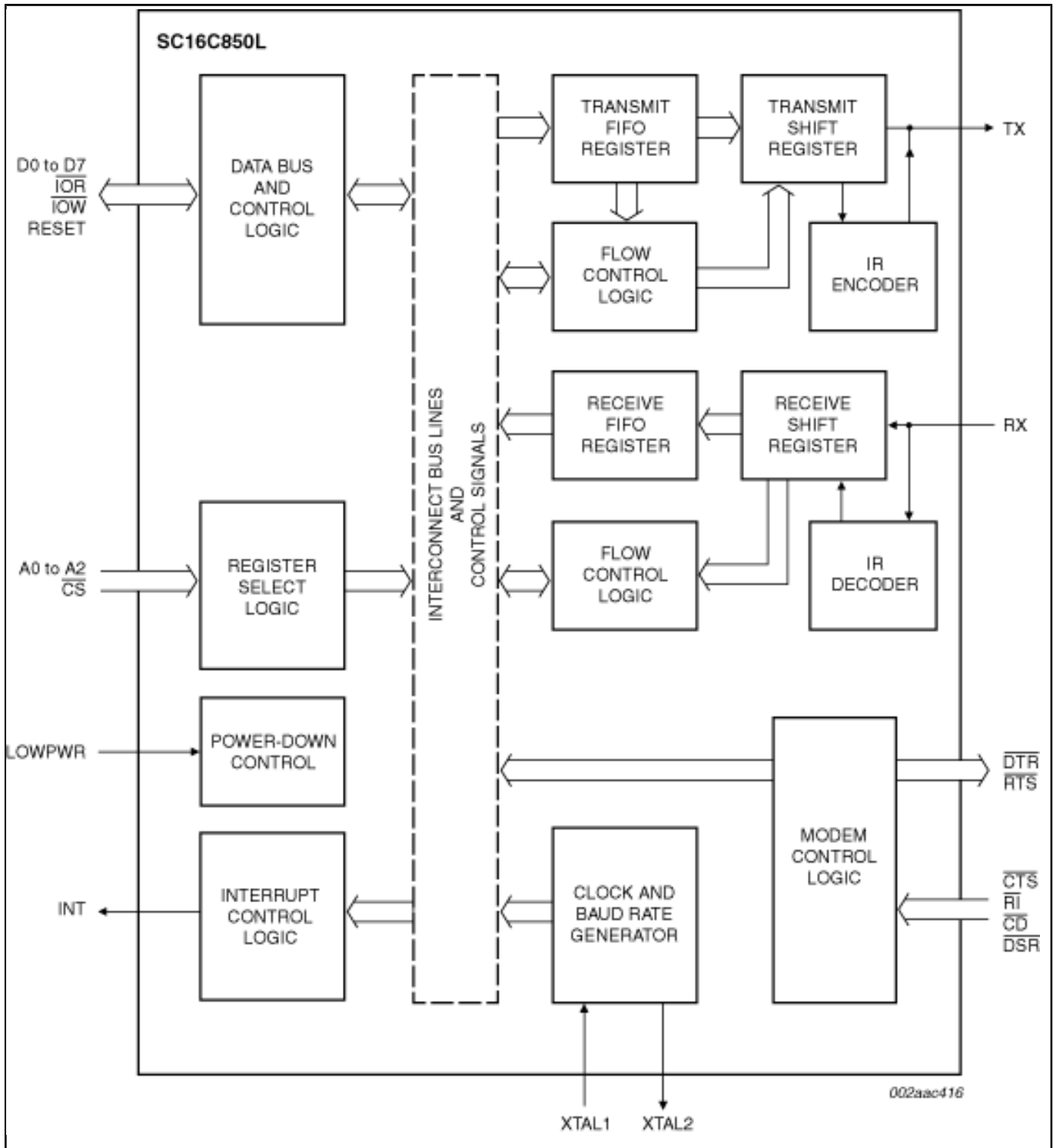

View additional information for [1.8 V Single UART, 16 Mode or 68 Mode Parallel Bus Interface](#).

Note: The information on this document is subject to change without notice.

NXP and the NXP logo are trademarks of NXP B.V. All other product or service names are the property of their respective owners. The related technology may be protected by any or all of patents, copyrights, designs and trade secrets. All rights reserved. © 2025 NXP B.V.