



# Mixed-Signal MCU for Automotive and Industrial Motor Control Applications

## S12ZVMA

Last Updated: Mar 12, 2024

The S12ZVMA MCU family is a programmable single-chip solution for simple loads needed to be controlled in the car remotely via LIN or PWM command. Integrated LIN-PHY, 12V-Vreg, and half-bridge gate driver allow building extremely compact solutions for DC-motors, solenoids or resistive loads.

## S12ZVMA-BD Block Diagram Block Diagram

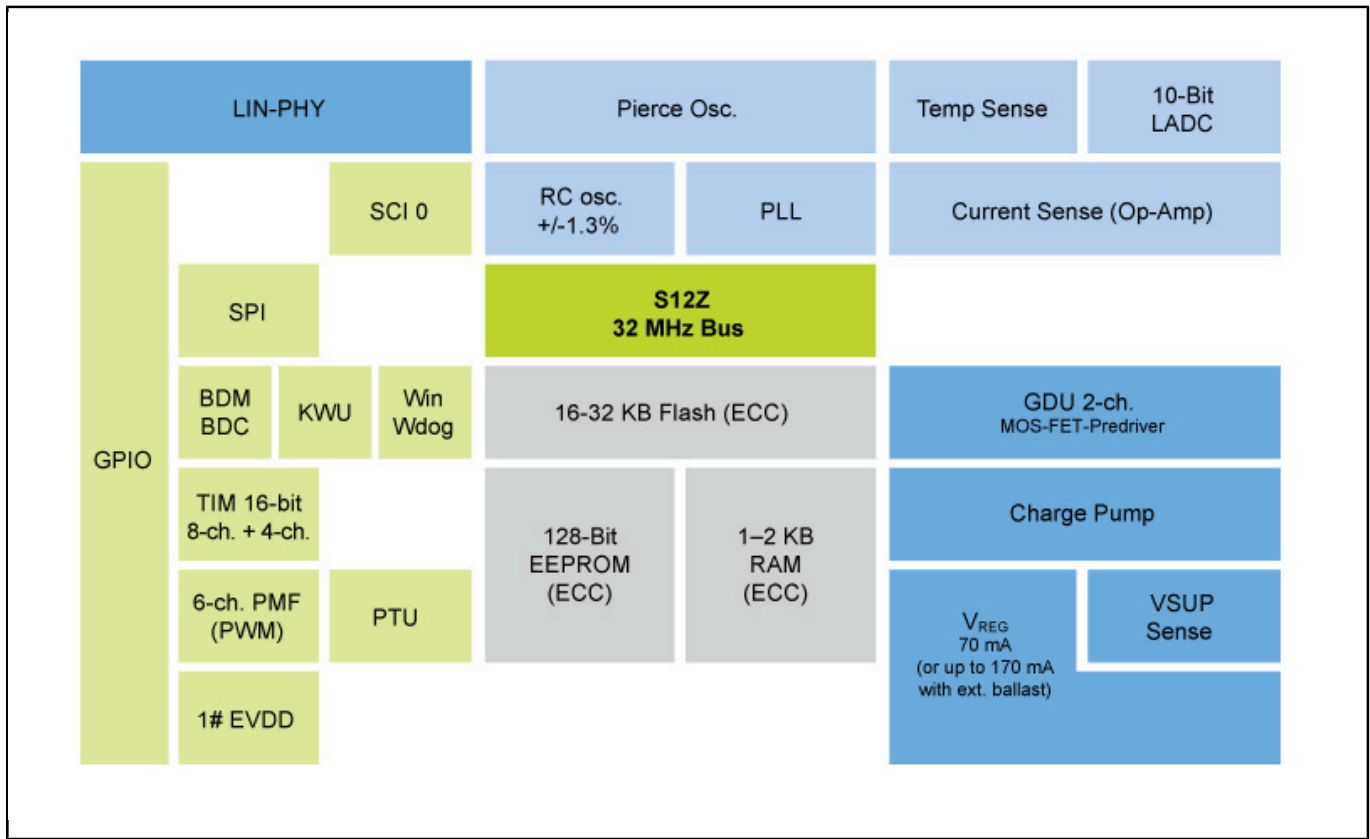

## DC Motor Application Using S12ZVMA Block Diagram

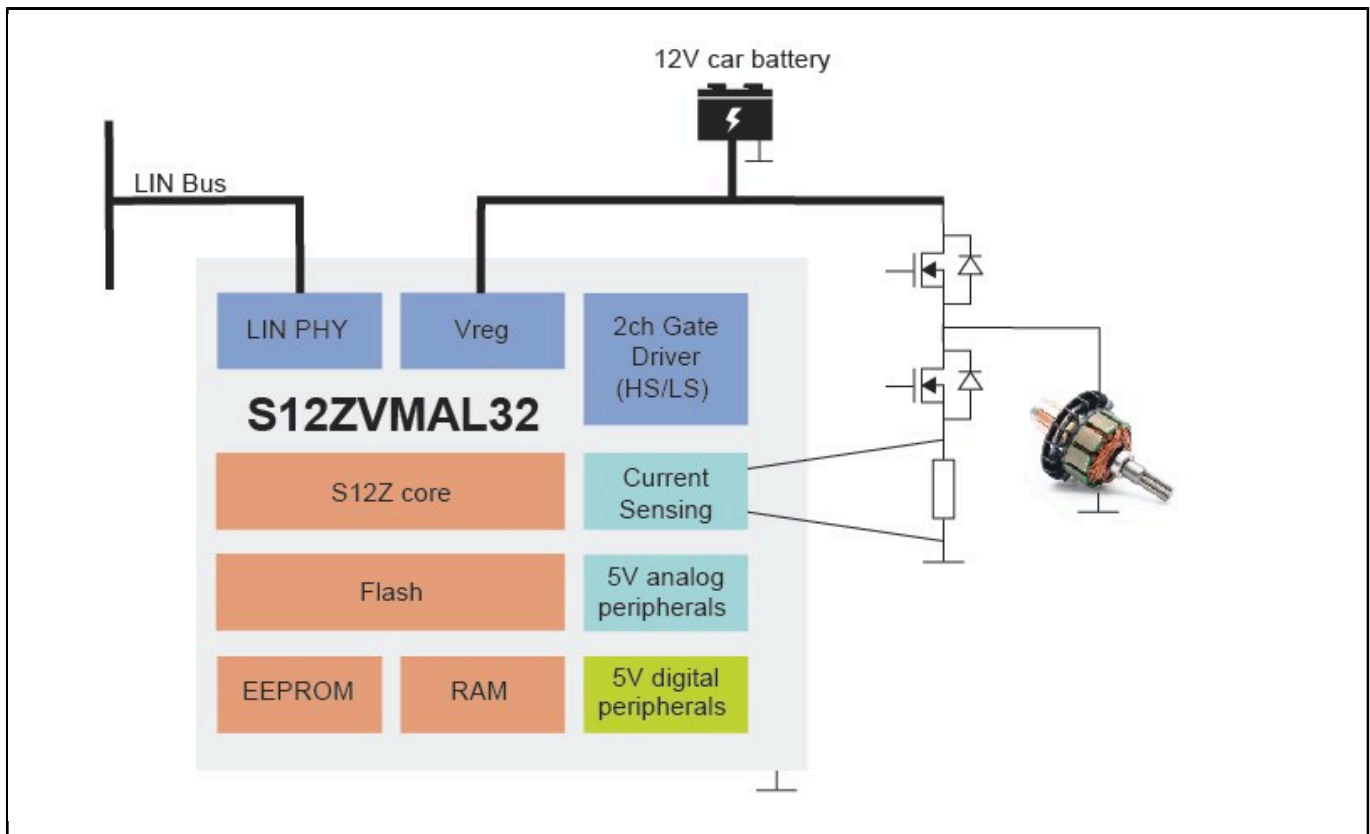

View additional information for [Mixed-Signal MCU for Automotive and Industrial Motor Control Applications](#).

**Note:** The information on this document is subject to change without notice.

---

**[www.nxp.com](http://www.nxp.com)**

NXP and the NXP logo are trademarks of NXP B.V. All other product or service names are the property of their respective owners. The related technology may be protected by any or all of patents, copyrights, designs and trade secrets. All rights reserved. © 2024 NXP B.V.