



# Ethernet Media Converter for Drones, Rovers, Mobile Robotics and Automotive

## RDDRONE-T1ADAPT

Last Updated: Apr 30, 2024

The RDDRONE-T1ADAPT media converter translates between automotive 2-wire Ethernet (100BASE-T1) to Fast Ethernet (100BASE-TX). Automotive IEEE 100BASE-T1 compliant, with 100Mbit/s transmit and receive capability up to at least 15m of unshielded twisted pair (UTP) cable.

Based on the TJA1101B 100BASE-T1 PHY and the LPC812 microcontroller Arm® M0+ MCU family, this plug and play tool is well suited for the evaluation and debugging of 100BASE-T1 Ethernet networks in various applications like Automotive, Industrial and IoT segments. Further, it can be used to develop distributed architectures where robotics nodes are connected over robust and reliable 100BASE-T1 Ethernet interfaces.

Learn more about our Ethernet products.

## Block Diagram

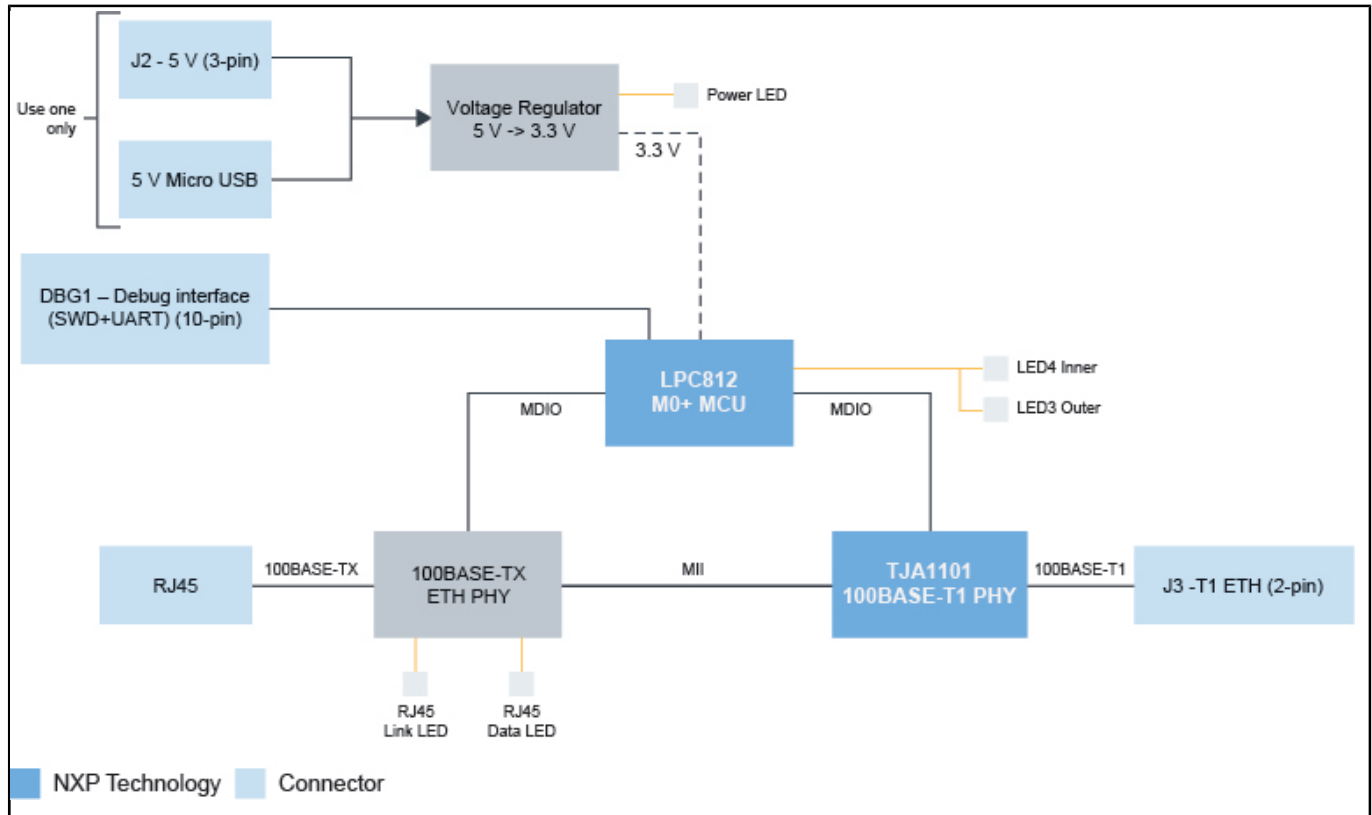

View additional information for [Ethernet Media Converter for Drones, Rovers, Mobile Robotics and Automotive](#).

Note: The information on this document is subject to change without notice.

[www.nxp.com](http://www.nxp.com)

NXP and the NXP logo are trademarks of NXP B.V. All other product or service names are the property of their respective owners. The related technology may be protected by any or all of patents, copyrights, designs and trade secrets. All rights reserved. © 2024 NXP B.V.