



# SuperSpeed USB 3.0 Redriver

## PTN36001HX

Last Updated: Aug 17, 2023

PTN36001 is a small, low power SuperSpeed USB 3.0 redriver IC that enhances signal quality by performing receive equalization on the deteriorated input signal followed by transmit de-emphasis maximizing system link performance for mobile applications. With its superior differential signal conditioning and enhancement capability, the device delivers significant flexibility and performance scaling for various systems with different PCB trace and cable channel conditions.

PTN36001 is a dual-channel device that supports data signaling rate of 5 Gbit/s through each channel. The data flow of one channel is facing the USB host and another channel is facing the USB peripheral or device. Each channel consists of a high-speed Transmit (Tx) differential lane and a high-speed Receive (Rx) differential lane.

PTN36001 is powered from a 1.8 V supply and is available in a small X2QFN12 package (1.25 mm × 2.1 mm × 0.35 mm) with 0.4 mm pitch.

# PTN36001 Block Diagram

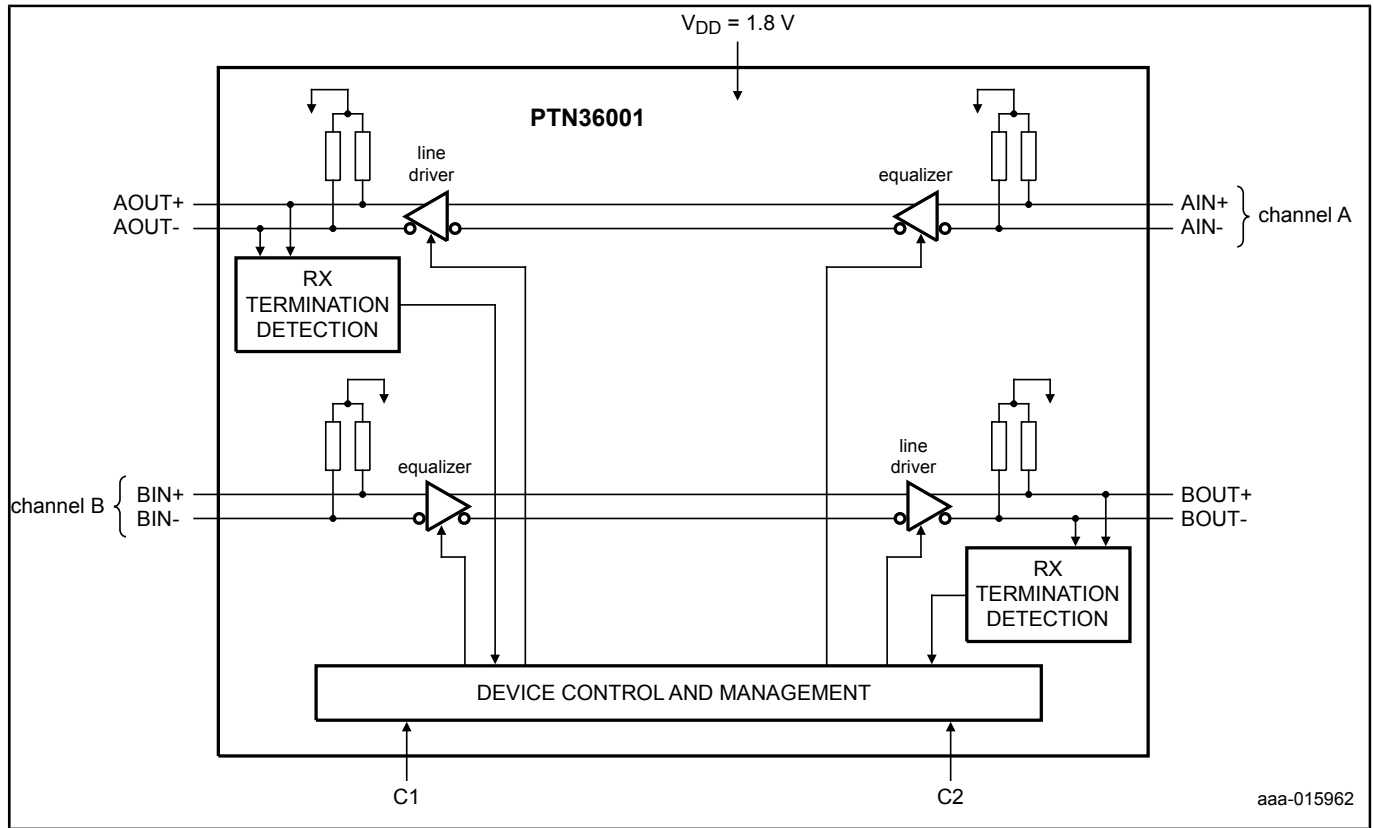

View additional information for [SuperSpeed USB 3.0 Redriver](#).

**Note:** The information on this document is subject to change without notice.

[www.nxp.com](http://www.nxp.com)

NXP and the NXP logo are trademarks of NXP B.V. All other product or service names are the property of their respective owners. The related technology may be protected by any or all of patents, copyrights, designs and trade secrets. All rights reserved. © 2024 NXP B.V.