



Two-Lane Displayport to VGA Adapter IC

PTN3392BS

新規採用非推奨

このページでは、新規設計を推奨しない製品に関する情報を掲載しています。

Last Updated: Oct 13, 2023

The PTN3392 is a DisplayPort to VGA adapter IC designed to connect a DisplayPort source to a VGA sink. The PTN3392 integrates a DisplayPort receiver and a high-speed triple video digital-to-analog converter that supports display resolutions from VGA to WUXGA. The PTN3392 supports either one or two DisplayPort v1.1a lanes operating at either 2.7 Gbit/s or 1.62 Gbit/s per lane. The PTN3392 has 'Flash-over-AUX' capability enabling simple firmware upgradability in the field.

The PTN3392 supports I²C-bus over AUX per DisplayPort v1.1a specification, and bridges the VESA DDC channel to the DisplayPort Interface.

The PTN3392 is designed for single supply and minimizes application costs. It can be powered directly from the DisplayPort source side 3.3 V supply without a need for additional core voltage regulator. The VGA output is powered down when there is no valid DisplayPort source data being transmitted. The PTN3392 also aids in monitor detection by performing load sensing and reporting sink connection status to the source.

PTN3392 Block Diagram

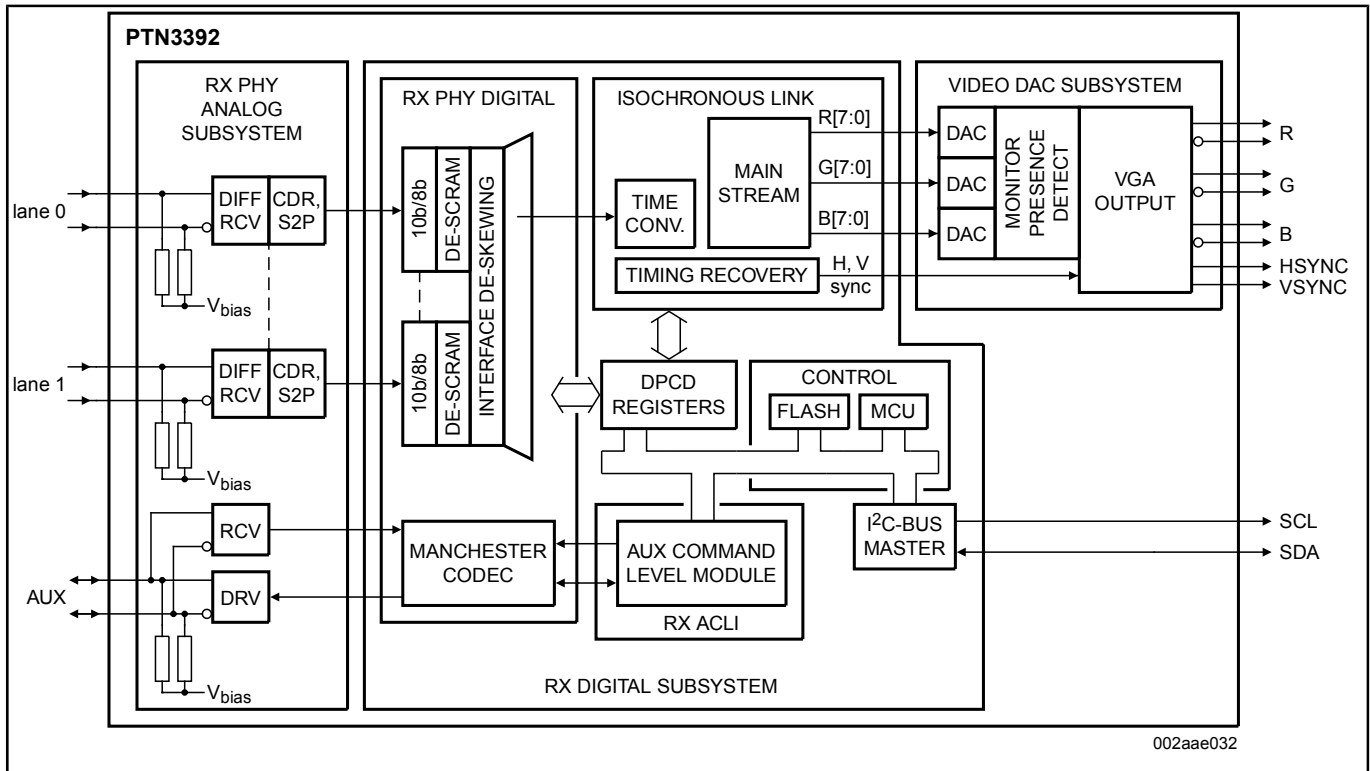

View additional information for [Two-Lane Displayport to VGA Adapter IC](#).

Note: The information on this document is subject to change without notice.

www.nxp.com

NXP and the NXP logo are trademarks of NXP B.V. All other product or service names are the property of their respective owners. The related technology may be protected by any or all of patents, copyrights, designs and trade secrets. All rights reserved. © 2024 NXP B.V.