



# I<sup>2</sup>C-Bus Controller

## PCF8584

Last Updated: Jun 15, 2022

The PCF8584 is an integrated circuit designed in CMOS technology which serves as an interface between most standard parallel-bus microcontrollers/microprocessors and the serial I<sup>2</sup>C-bus. The PCF8584 provides both controller and target functions.

Communication with the I<sup>2</sup>C-bus is carried out on a byte-wise basis using interrupt or polled handshake. It controls all the I<sup>2</sup>C-bus specific sequences, protocol, arbitration and timing. The PCF8584 allows parallel-bus systems to communicate bidirectionally with the I<sup>2</sup>C-bus.

# PCF8584 Block Diagram Block Diagram

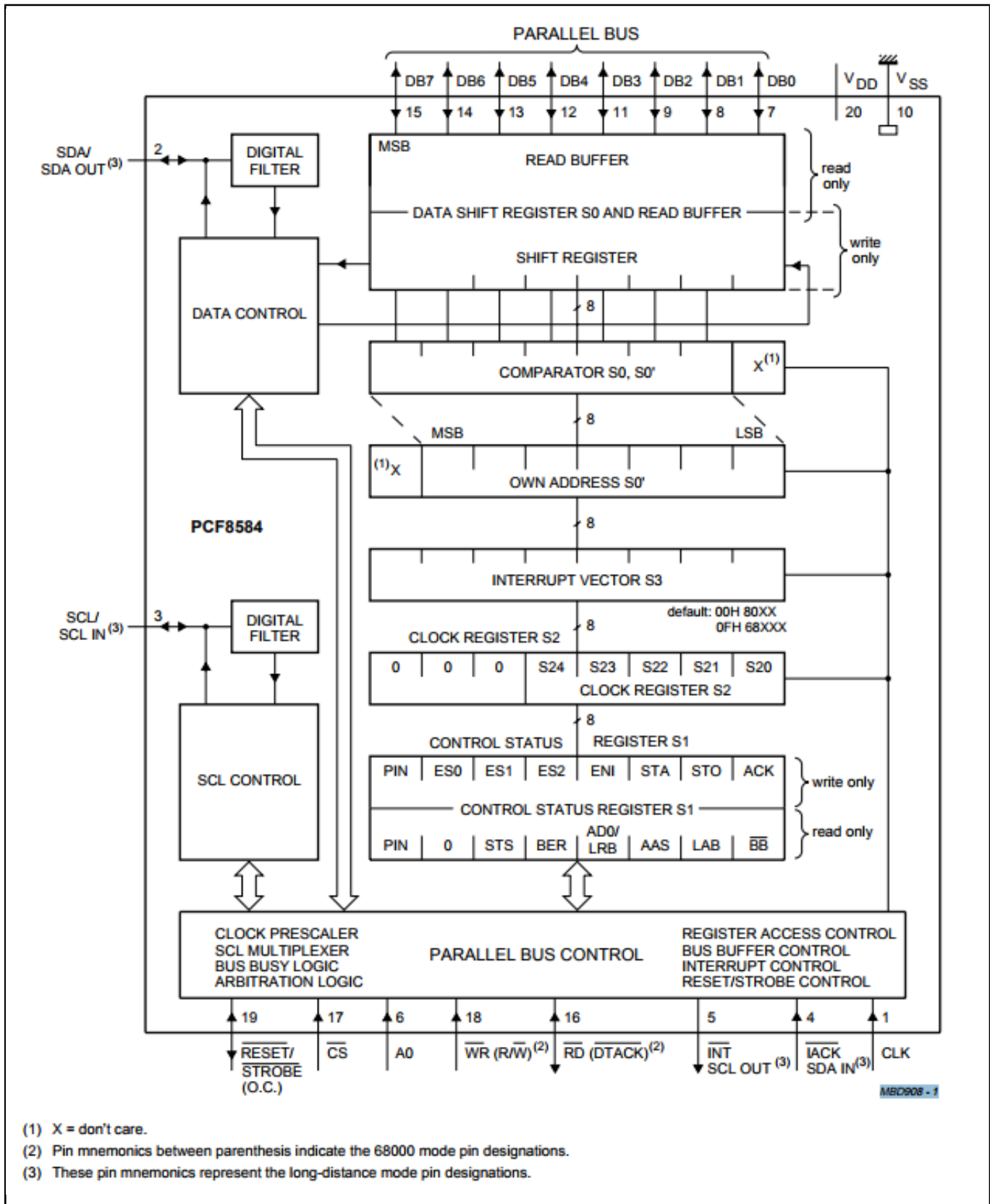

**Note:** The information on this document is subject to change without notice.

---

**[www.nxp.com](http://www.nxp.com)**

NXP and the NXP logo are trademarks of NXP B.V. All other product or service names are the property of their respective owners. The related technology may be protected by any or all of patents, copyrights, designs and trade secrets. All rights reserved. © 2024 NXP B.V.