



# Universal LCD Driver for Low Multiplex Rates

## PCF8562TT

新規採用非推奨

このページでは、新規設計を推奨しない製品に関する情報を掲載しています。

Last Updated: Mar 19, 2024

The PCF8562 is a peripheral device which interfaces to almost any Liquid Crystal Display (LCD) with low multiplex rates. It generates the drive signals for any static or multiplexed LCD containing up to four backplanes and up to 32 segments. The PCF8562 is compatible with most microcontrollers and communicates via the two-line bidirectional I<sup>2</sup>C-bus. Communication overheads are minimized by a display RAM with auto-incremented addressing, by hardware subaddressing and by display memory switching (static and duplex drive modes).

PCF8562TT should not be used for new designs. Recommended replacement: PCF85162T

## PCF8562 Block Diagram

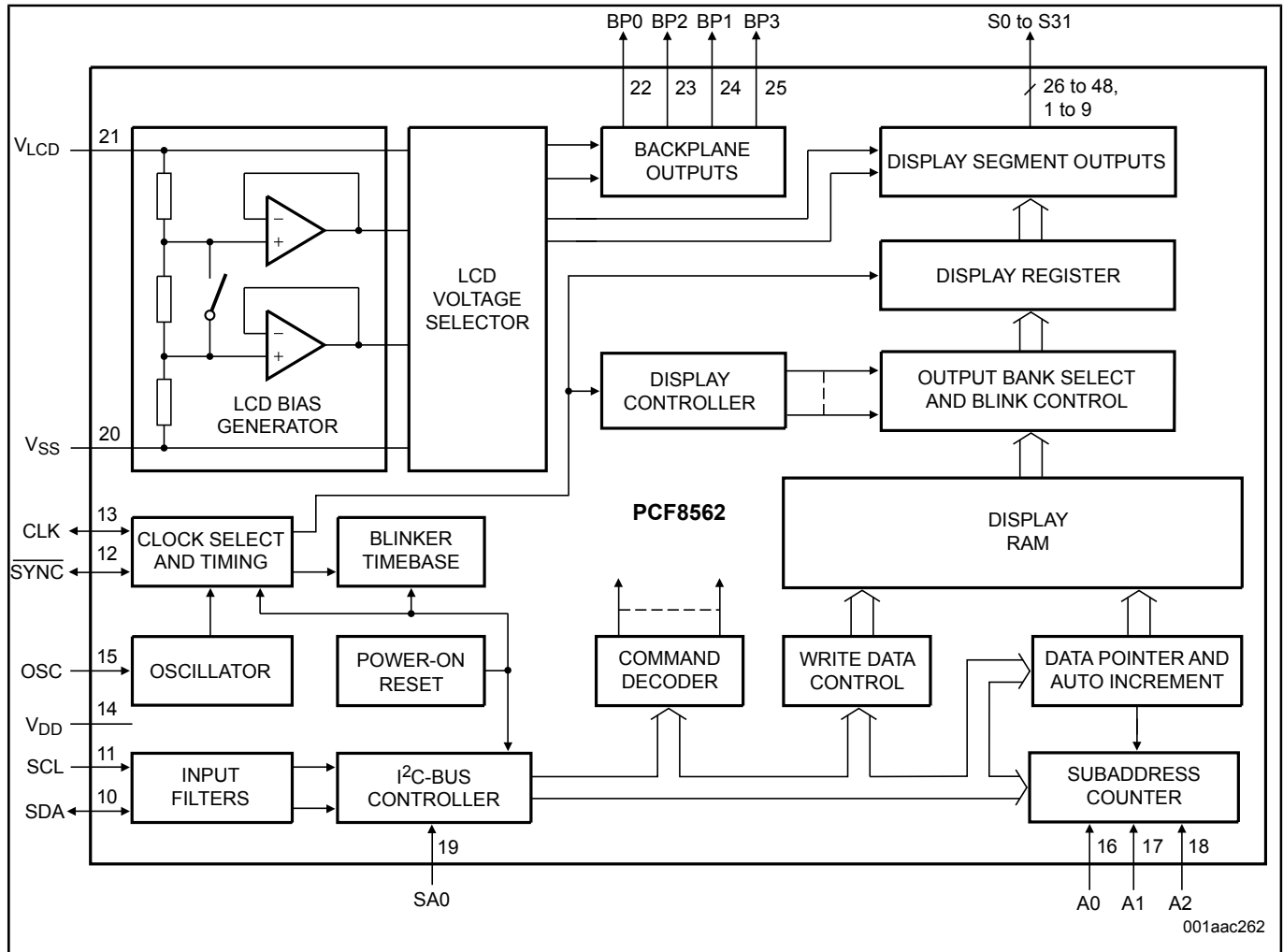

## PCF8562TT Block Diagram

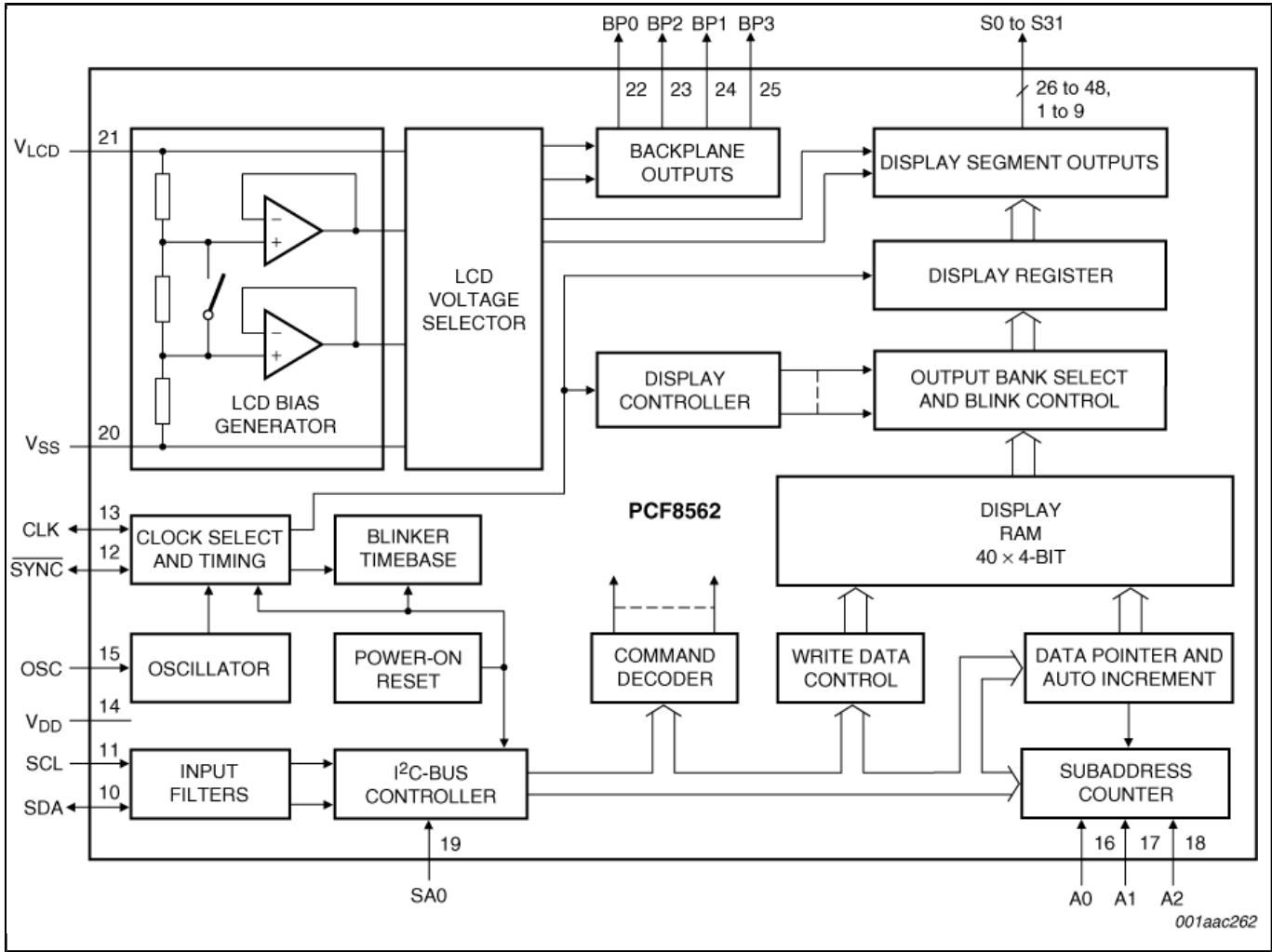

View additional information for [Universal LCD Driver for Low Multiplex Rates](#).

Note: The information on this document is subject to change without notice.

[www.nxp.com](http://www.nxp.com)

NXP and the NXP logo are trademarks of NXP B.V. All other product or service names are the property of their respective owners. The related technology may be protected by any or all of patents, copyrights, designs and trade secrets. All rights reserved. © 2024 NXP B.V.