



Universal LCD Driver for Low Multiplex Rates

PCF8533U

アーカイブス

このページには、製造中止（生産終了）となった製品の情報が記載されています。本ページに記載されている仕様および情報は、過去の参考情報です。

Last Updated: Aug 11, 2023

The PCF8533 is a peripheral device which interfaces to almost any Liquid Crystal Display (LCD) with low multiplex rates. It generates the drive signals for any static or multiplexed LCD containing up to four backplanes and up to 80 segments and can easily be cascaded for larger LCD applications. The PCF8533 is compatible with most microcontrollers and communicates via the two-line bidirectional I²C-bus. Communication overheads are minimized by a display RAM with auto-incremental addressing, by hardware subaddressing and by display memory switching (static and duplex drive modes).

PCF8533 Block Diagram

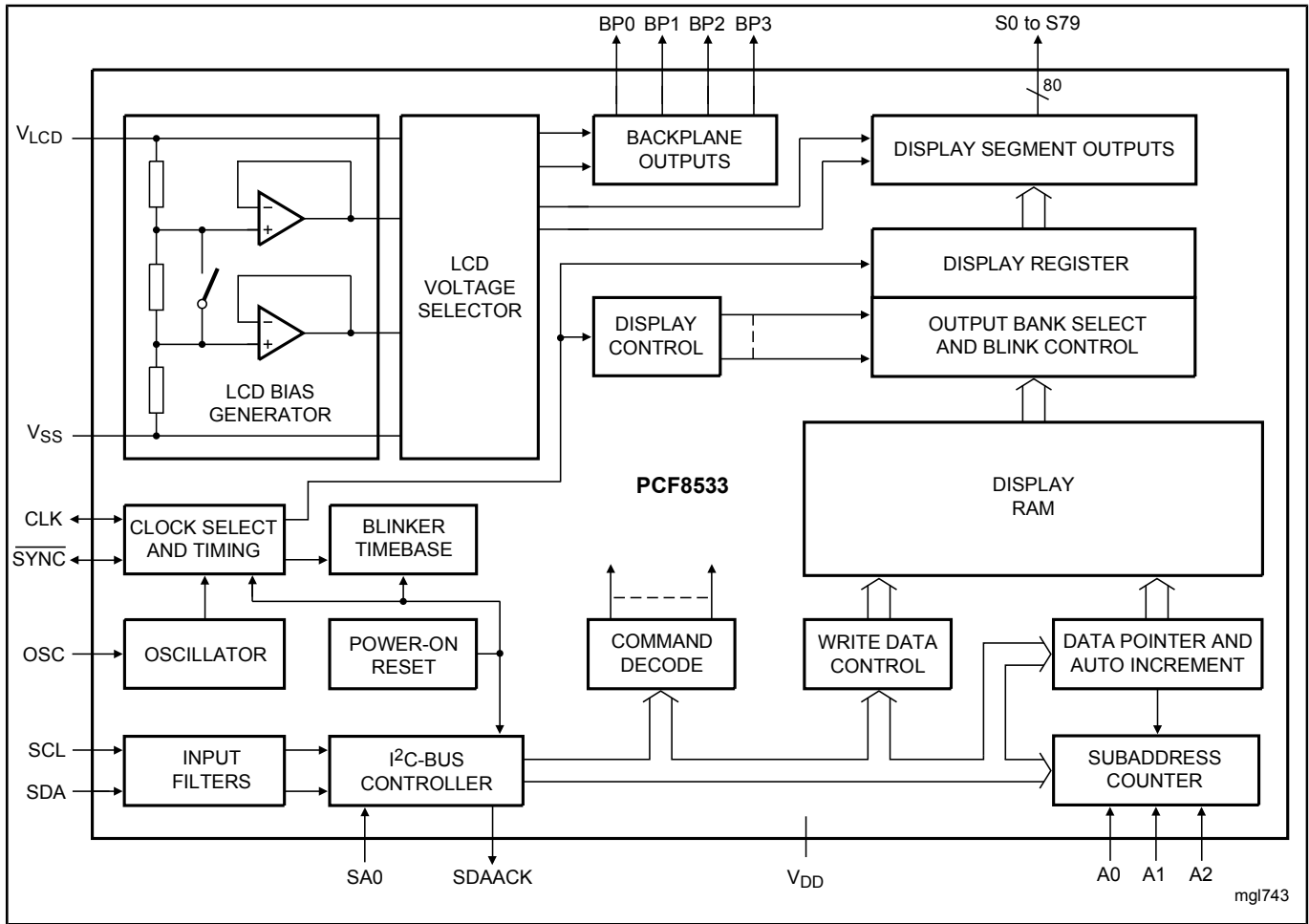

View additional information for [Universal LCD Driver for Low Multiplex Rates](#).

Note: The information on this document is subject to change without notice.

www.nxp.com

NXP and the NXP logo are trademarks of NXP B.V. All other product or service names are the property of their respective owners. The related technology may be protected by any or all of patents, copyrights, designs and trade secrets. All rights reserved. © 2024 NXP B.V.