



LCD drivers

PCF2100CT

アーカイブス

このページには、製造中止（生産終了）となった製品の情報が記載されています。本ページに記載されている仕様および情報は、過去の参考情報です。

Last Updated: Jul 21, 2023

The PCF21xxC family are single-chip, silicon gate CMOS LCD driver circuits. A 3-line bus (CBUS) structure enables serial data transfer with microcontrollers.

PCF21XXC_FAM Block Diagram Block Diagram

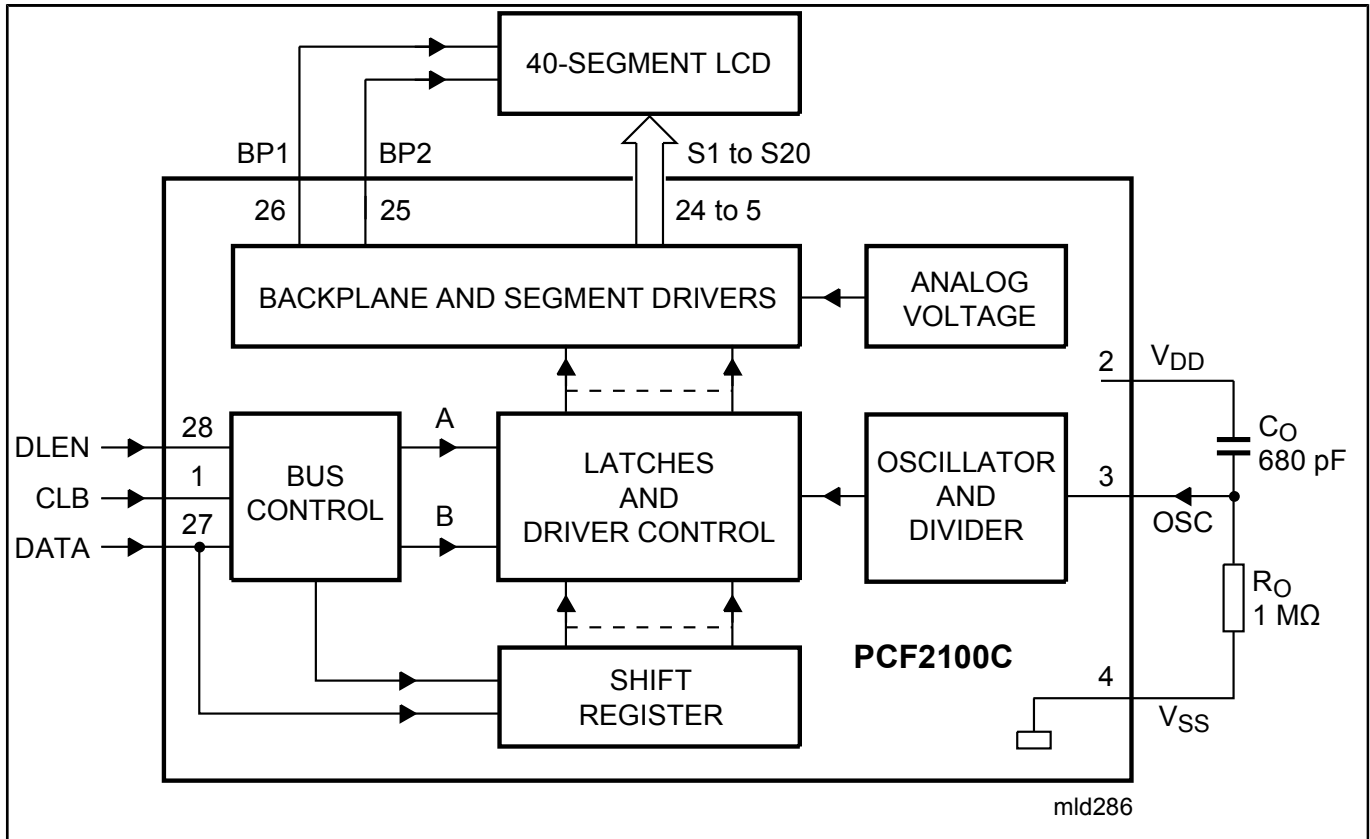

Block diagram: PCF2100CT, PCF2111CT, PCF2112CP, PCF2112CT Block Diagram

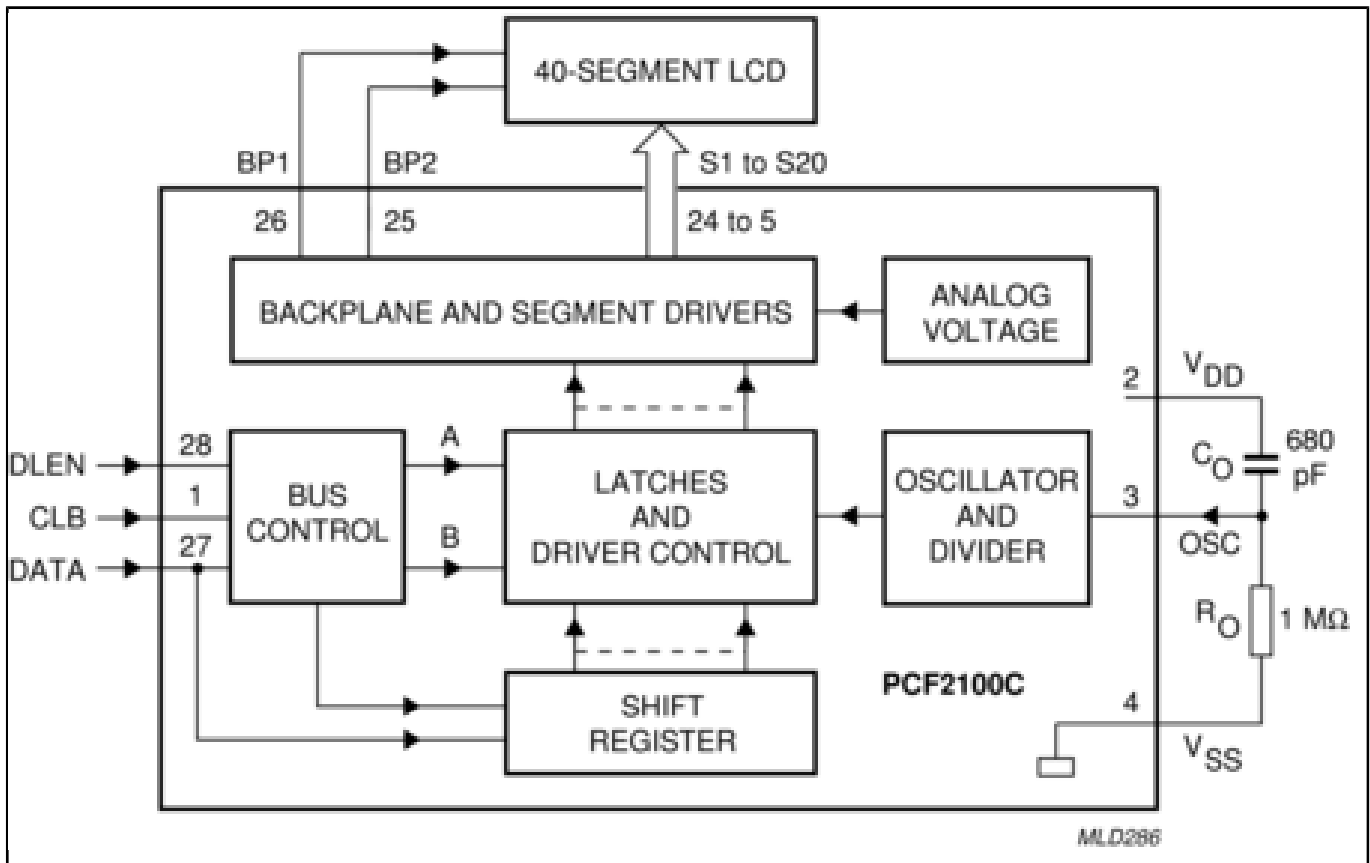

Block diagram: PCF2100CT, PCF2111CT, PCF2112CP, PCF2112CT Block Diagram

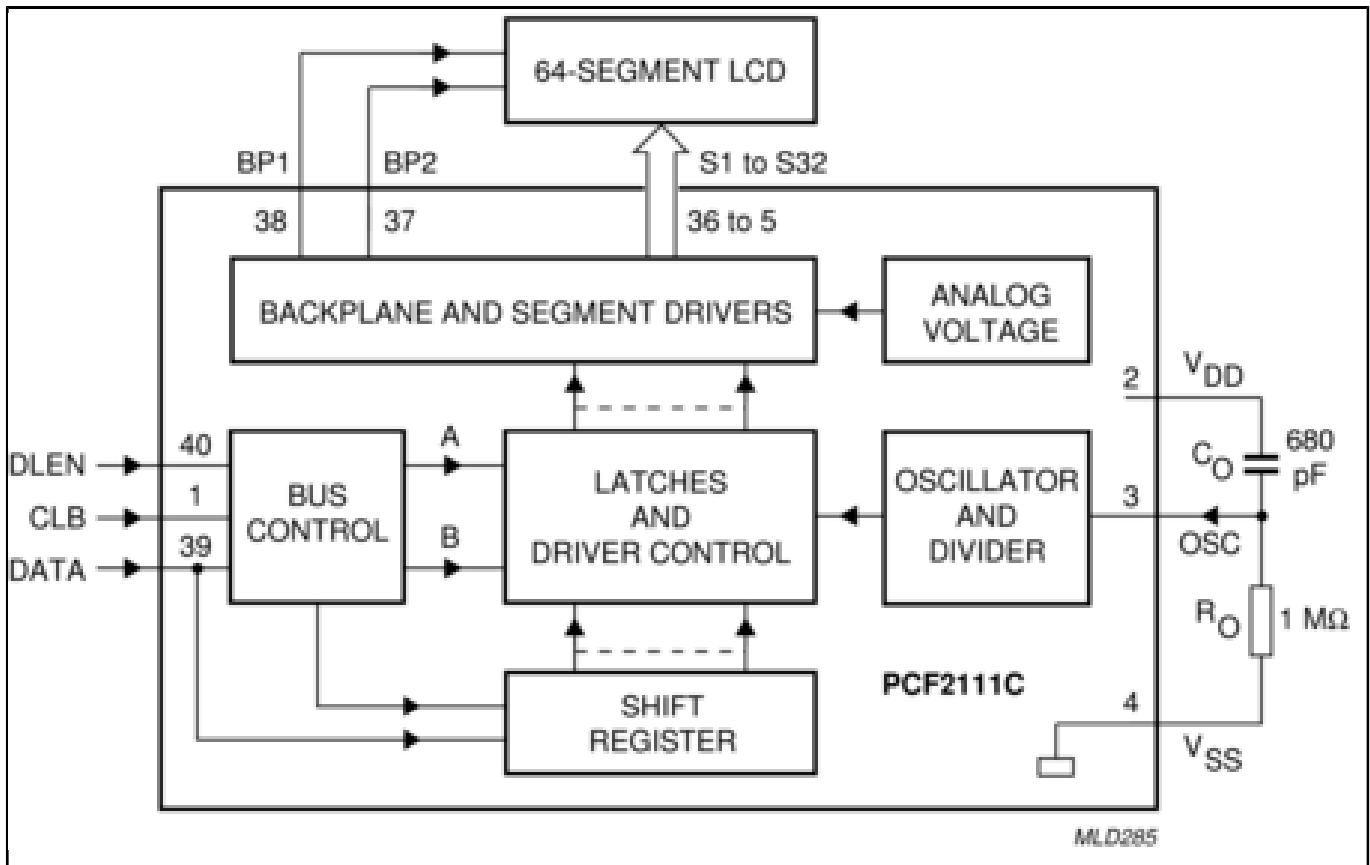

Block diagram: PCF2100CT, PCF2111CT, PCF2112CP, PCF2112CT Block Diagram

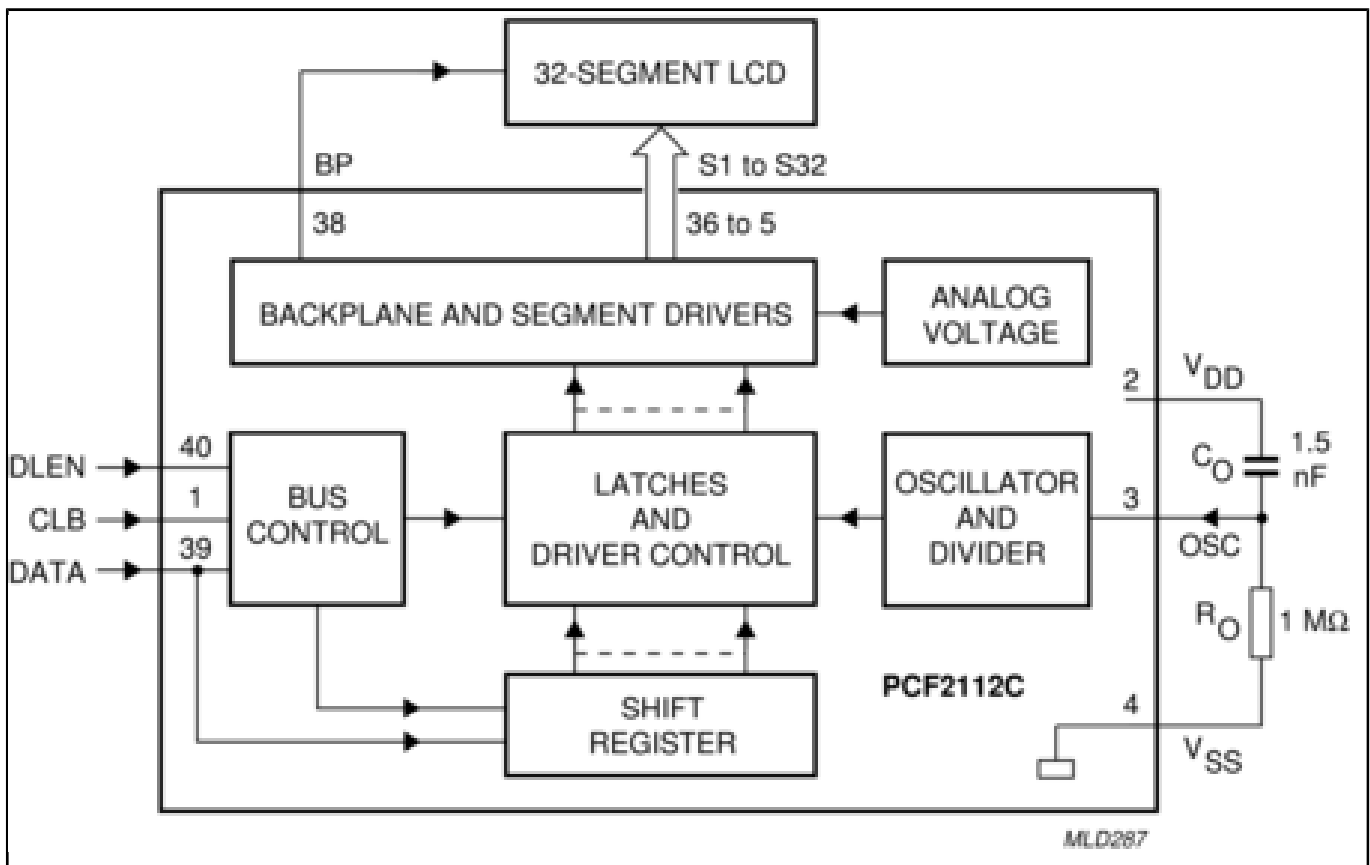

View additional information for [LCD drivers](#).

Note: The information on this document is subject to change without notice.

www.nxp.com

NXP and the NXP logo are trademarks of NXP B.V. All other product or service names are the property of their respective owners. The related technology may be protected by any or all of patents, copyrights, designs and trade secrets. All rights reserved. © 2024 NXP B.V.