



# 8-Bit Fm+ I<sup>2</sup>C-Bus 100 mA 40 V LED Driver

## PCA9624

### アーカイブス

このページには、製造中止（生産終了）となった製品の情報が記載されています。本ページに記載されている仕様および情報は、過去の参考情報です。

Last Updated: Jul 25, 2023

The PCA9624 is an I<sup>2</sup>C-bus controlled 8-bit LED driver optimized for voltage switch dimming and blinking 100 mA Red/Green/Blue/Amber (RGBA) LEDs. Each LED output has its own 8-bit resolution (256 steps) fixed frequency individual PWM controller that operates at 97 kHz with a duty cycle that is adjustable from 0 % to 99.6 % to allow the LED to be set to a specific brightness value. An additional 8-bit resolution (256 steps) group PWM controller has both a fixed frequency of 190 Hz and an adjustable frequency between 24 Hz to once every 10.73 seconds with a duty cycle that is adjustable from 0 % to 99.6 % that is used to either dim or blink all LEDs with the same value.

Each LED output can be off, on (no PWM control), set at its individual PWM controller value or at both individual and group PWM controller values. The PCA9624 operates with a supply voltage range of 2.3 V to 5.5 V and the 100 mA open-drain outputs allow voltages up to 40 V.

The PCA9624 is one of the first LED controller devices in a new Fast-mode Plus (Fm+) family. Fm+ devices offer higher frequency (up to 1 MHz) and more densely populated bus operation (up to 4000 pF).

The active LOW Output Enable input pin (OE) blinks all the LED outputs and can be used to externally PWM the outputs, which is useful when multiple devices must be dimmed or blinked together without using software control.

Software programmable LED group and three Sub Call I<sup>2</sup>C-bus addresses allow all or defined groups of PCA9624 devices to respond to a common I<sup>2</sup>C-bus address, allowing, for example, all red LEDs to be turned on or off at the same time or marquee chasing effect, thus minimizing I<sup>2</sup>C-bus commands. Seven hardware address pins allow up to 126 devices on the same bus.

The Software Reset (SWRST) Call allows the leader to perform a reset of the PCA9624 through the I<sup>2</sup>C-bus, identical to the Power-On Reset (POR) that initializes the registers to their default state causing the outputs to be set HIGH (LED off). This allows an easy and quick way to reconfigure all device registers to the same condition.

The PCA9624 and PCA9634 software are identical and if the PCA9624 on-chip 100 mA NAND FETs do not provide enough current or voltage to drive the LEDs, then the PCA9634 with larger current or higher voltage external drivers can be used.

### PCA9624 Block Diagram

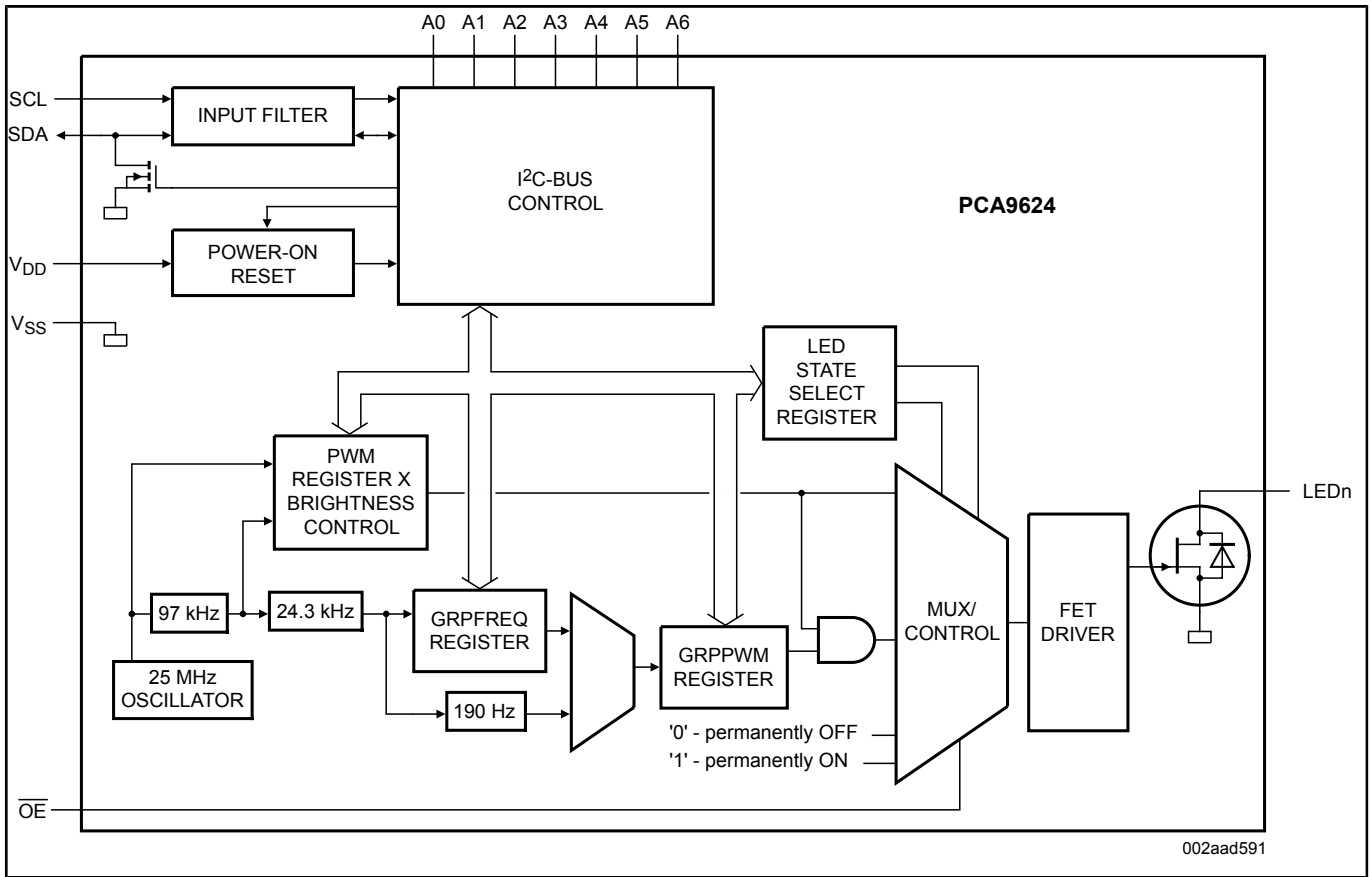

### PCA9624BS, PCA9624PW Block Diagram

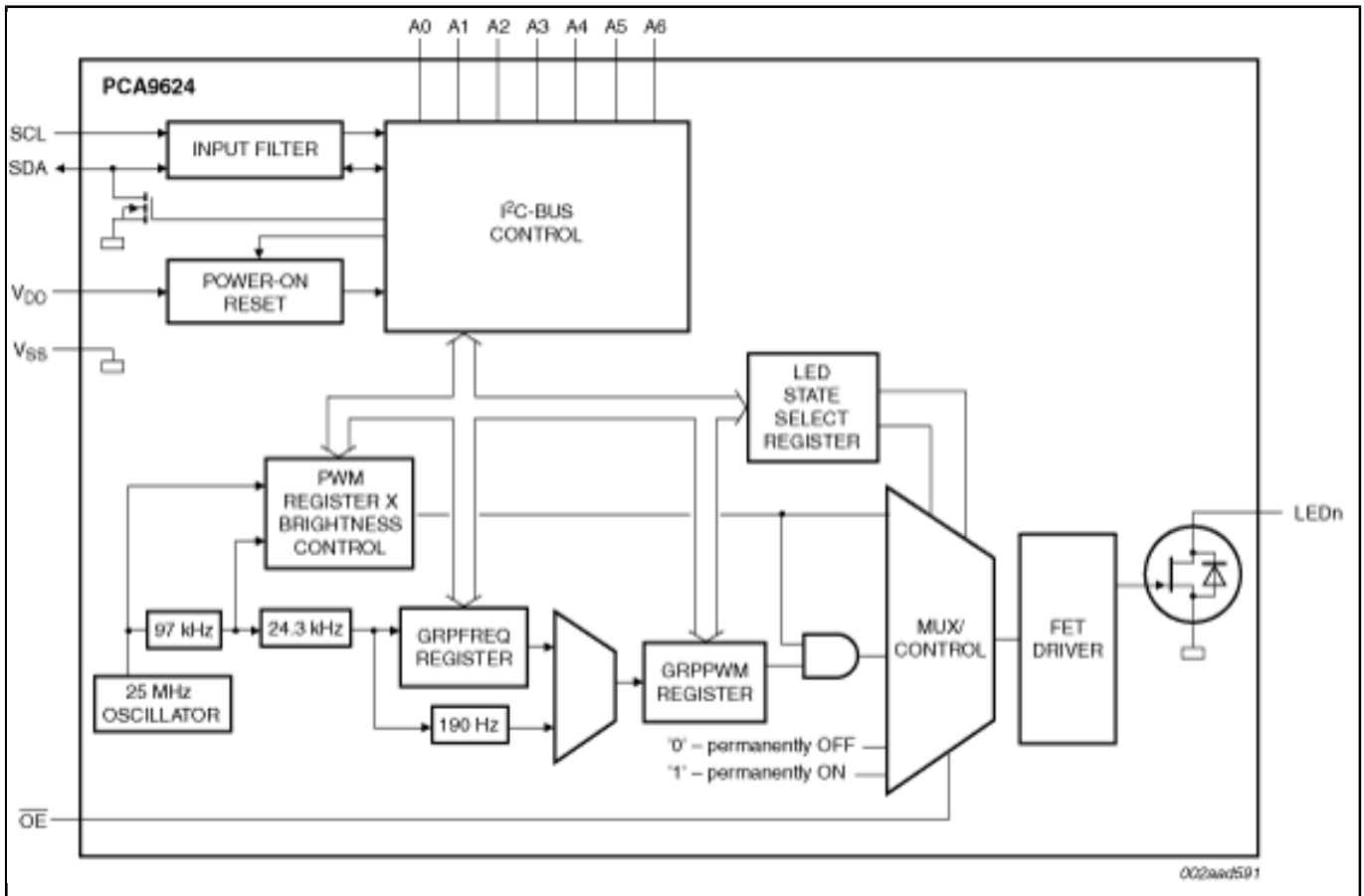

View additional information for [8-Bit Fm+ I<sup>2</sup>C-Bus 100 MA 40 V LED Driver](#).

**Note:** The information on this document is subject to change without notice.

---

**[www.nxp.com](http://www.nxp.com)**

NXP and the NXP logo are trademarks of NXP B.V. All other product or service names are the property of their respective owners. The related technology may be protected by any or all of patents, copyrights, designs and trade secrets. All rights reserved. © 2024 NXP B.V.