



32 KHz Watch Circuit with Programmable Adaptive Motor Pulse and Pulse Period

PCA2003U

Last Updated: Jan 31, 2024

The PCA2003 is a CMOS integrated circuit for battery operated wrist watches with a 32 kHz quartz crystal as timing element and a bipolar 1 Hz stepping motor. The quartz crystal oscillator and the frequency divider are optimized for minimum power consumption. A timing accuracy of 1 ppm is achieved with a programmable, digital frequency adjustment.

To obtain the minimum overall power consumption for the watch, an automatic motor pulse adaptation function is provided. The circuit supplies only the minimum drive current, which is necessary to ensure a correct motor step. Changing the drive current of the motor is achieved by chopping the motor pulse with a variable duty cycle. The pulse period and the range of the variable duty cycle can be programmed to suit different types of motors. The automatic pulse adaptation scheme is based on a safe dynamic detection of successful motor steps.

A pad RESET is provided (used for stopping the motor) for accurate time setting and for accelerated testing of the watch.

PCA2003 -BD Block Diagram

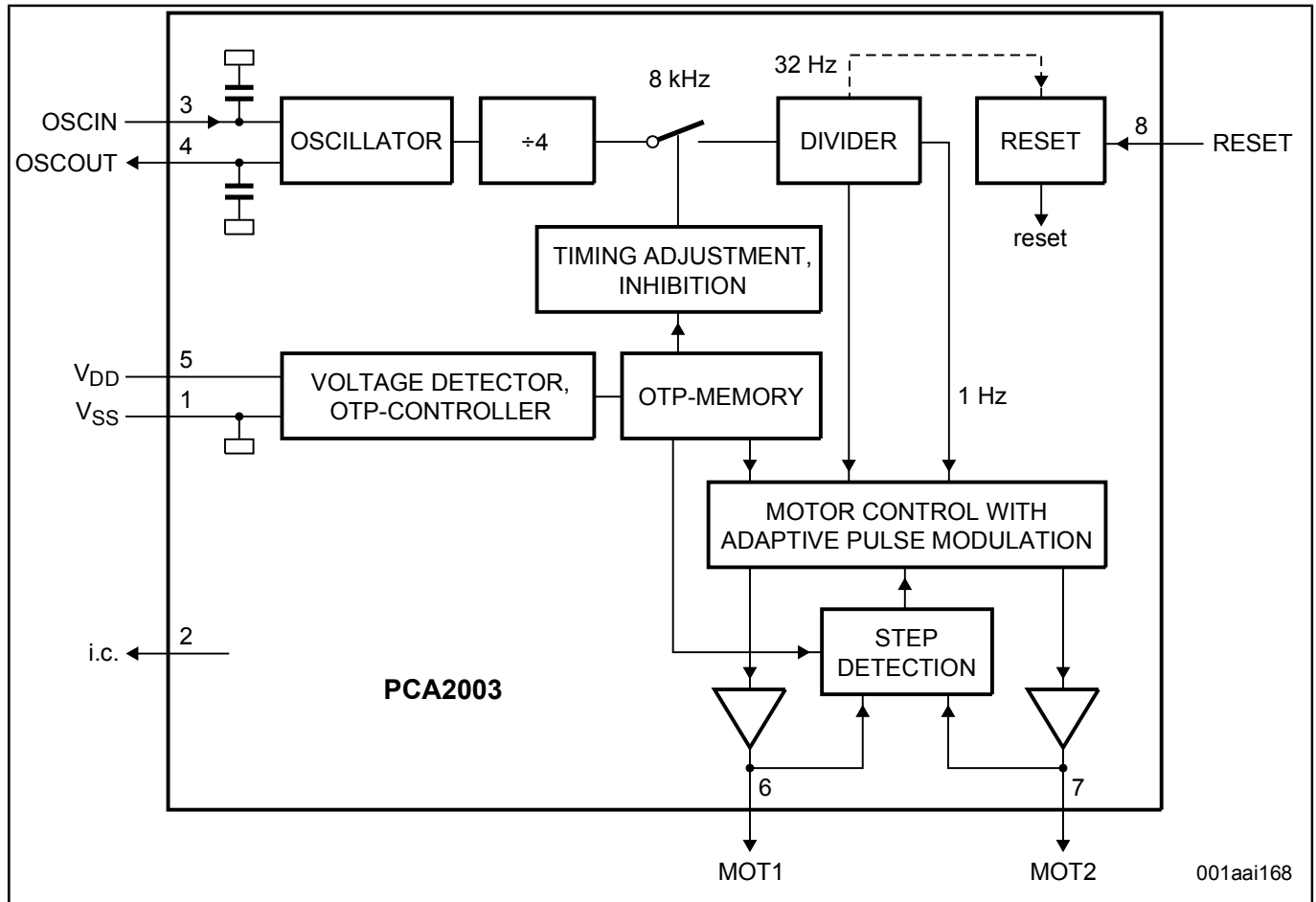

Block diagram: PCA2003U Block Diagram

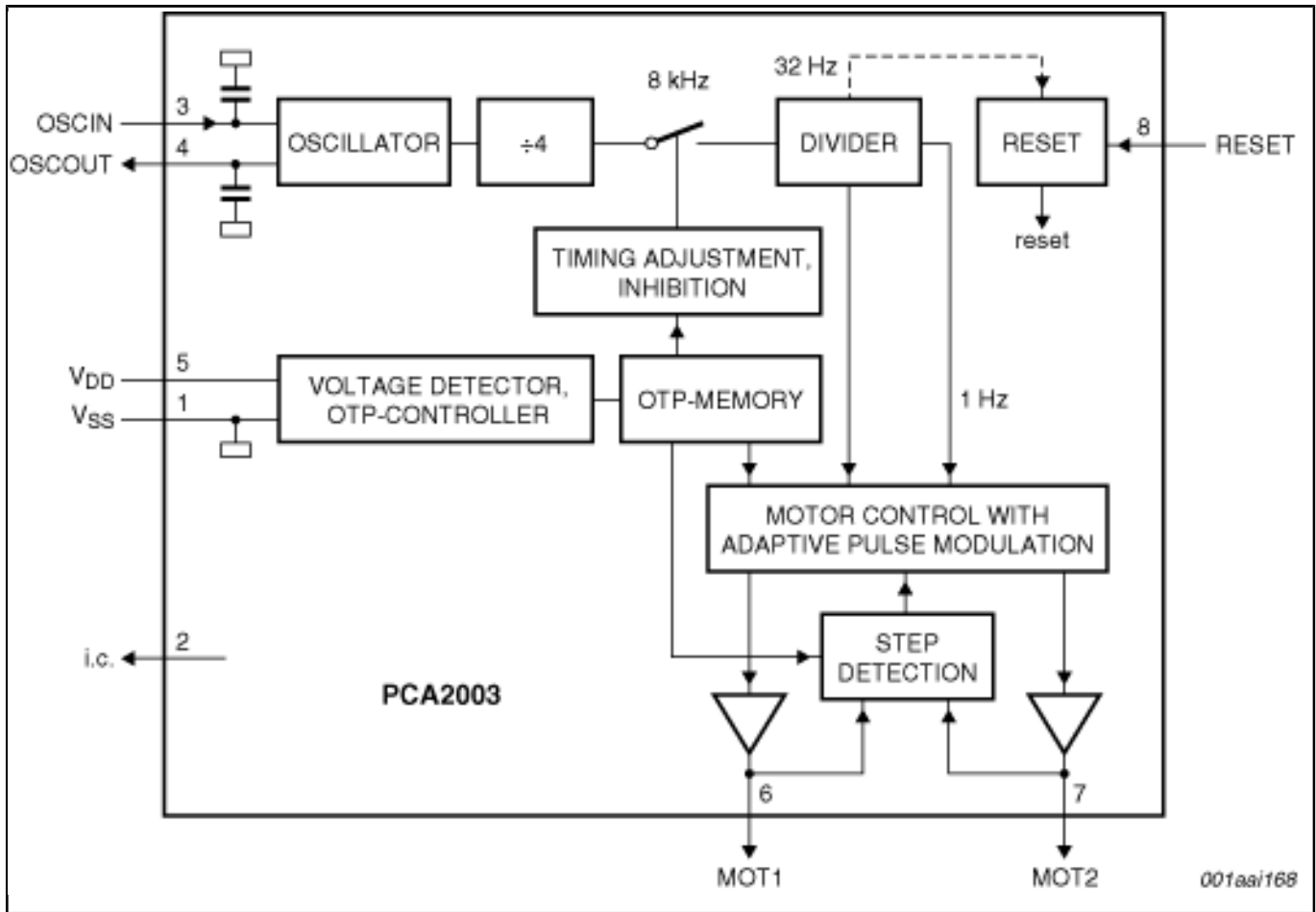

View additional information for [32 KHz Watch Circuit with Programmable Adaptive Motor Pulse and Pulse Period](#).

Note: The information on this document is subject to change without notice.

www.nxp.com

NXP and the NXP logo are trademarks of NXP B.V. All other product or service names are the property of their respective owners. The related technology may be protected by any or all of patents, copyrights, designs and trade secrets. All rights reserved. © 2024 NXP B.V.