



8-Bit Microcontroller with On-Chip CAN

P80C592FFA

Last Updated: Mar 8, 2023

The P8xC592 is a single-chip 8-bit high-performance microcontroller with on-chip CAN-controller, derived from the 80C51 microcontroller family.

It uses the powerful 80C51 instruction set.

The P8xC592 is manufactured in an advanced CMOS process, and is designed for use in automotive and general industrial applications. In addition to the 80C51 standard features, the device provides a number of dedicated hardware functions for these applications.

Two versions of the P8xC592 will be offered:

- P80C592 (without ROM)
- P83C592 (with ROM).

Hereafter these versions will be referred to as P8xC592.

The temperature range includes (max. fCLK= 16 MHz):

- -40 to +85 °C version, for general applications
- -40 to +125 °C version for automotive applications.

The P8xC592 combines the functions of the P8xC552 (microcontroller) and the PCA82C200 (Philips CAN-controller) with the following enhanced features:

- 16 kbytes Program Memory
- 2 x 256 bytes Data Memory
- DMA between CAN Transmit/Receive Buffer and internal RAM.

The main differences between P8xC592 and P8xC552 are:

- 16 kbytes programmable ROM (P8xC552 has 8 kbytes)
- Additional 256 bytes RAM
- A CAN-controller instead of the I²C-serial interface.

Block diagram: P80C592FFA, P80CE598FFB Block Diagram

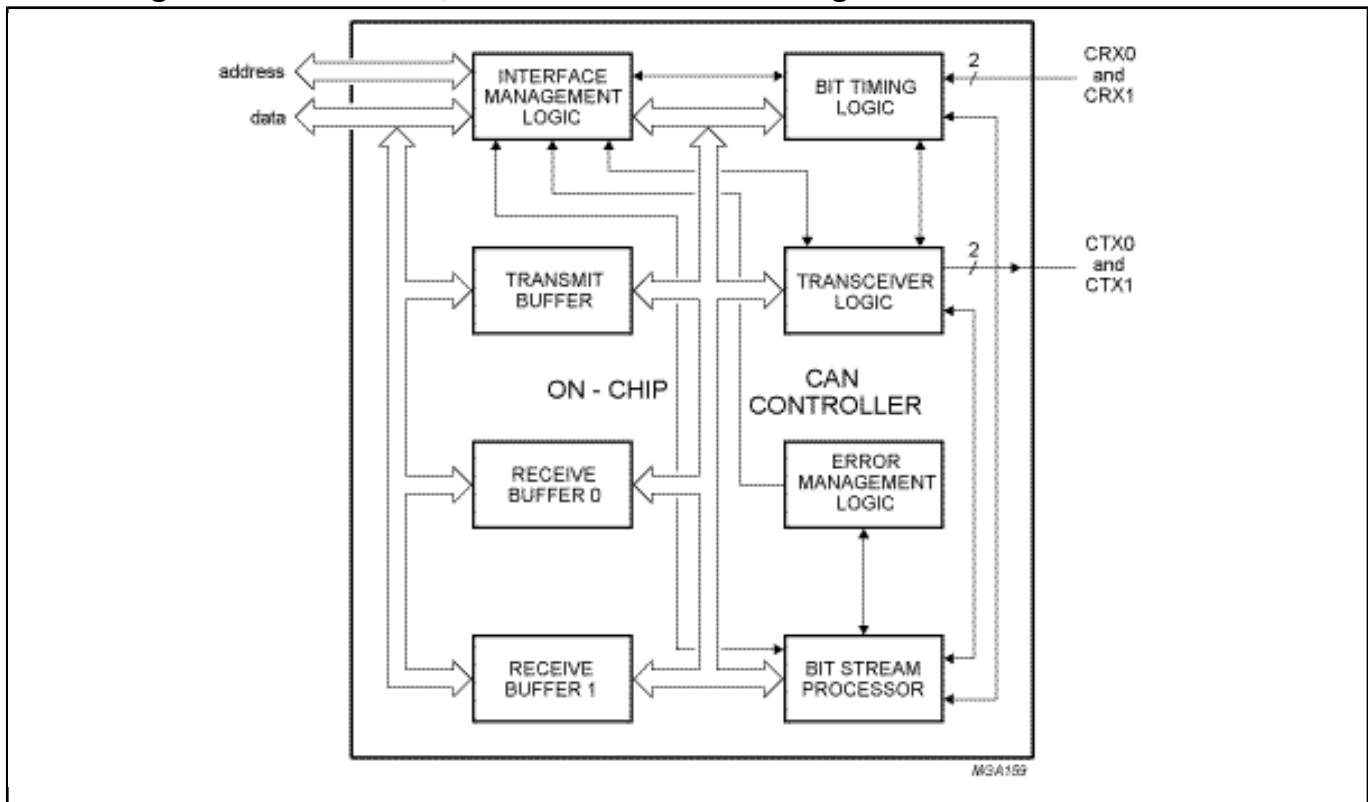

Block diagram: P80C592FFA, P80CE598FFB Block Diagram

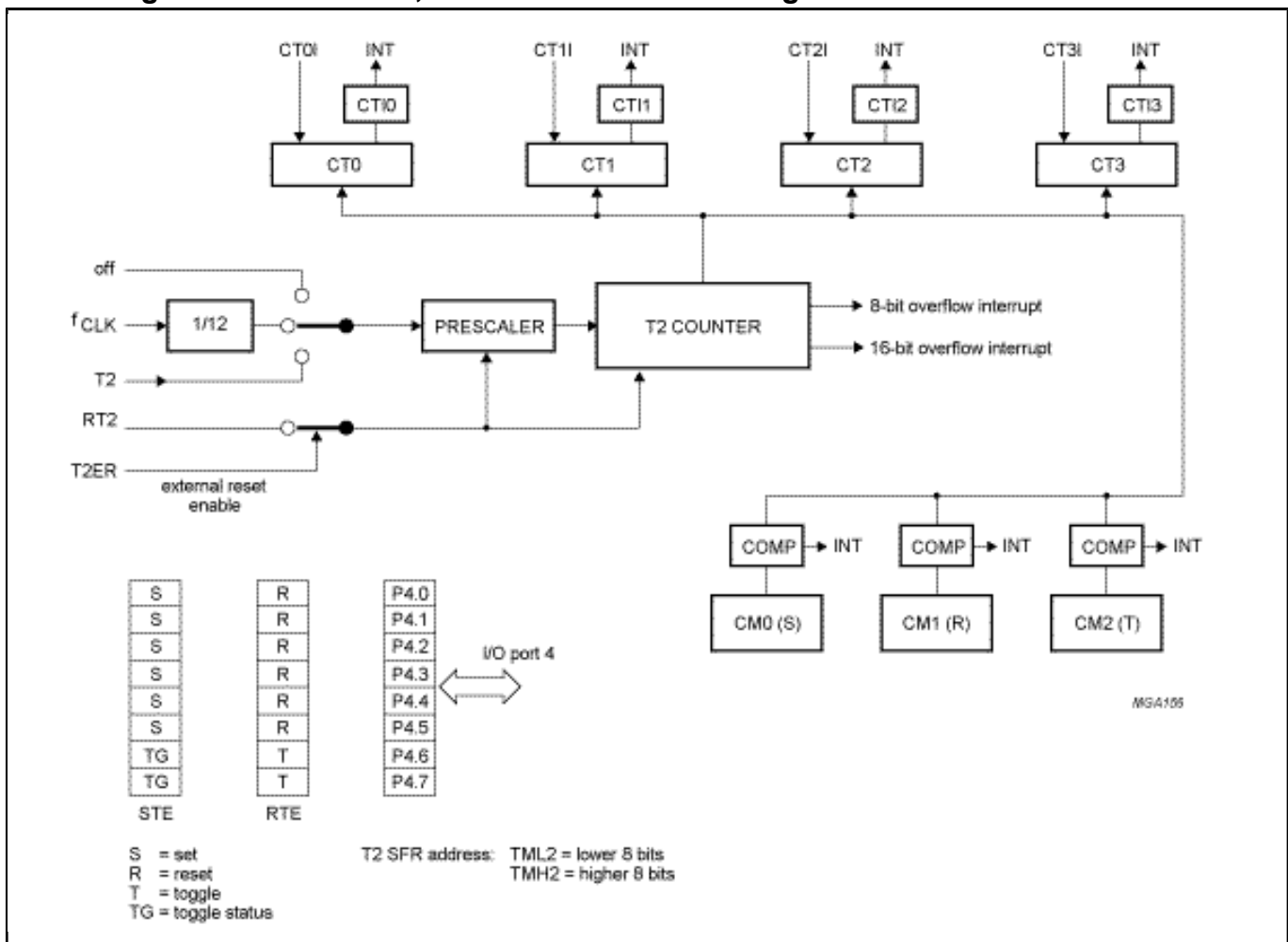

Block diagram: P80C592FFA Block Diagram

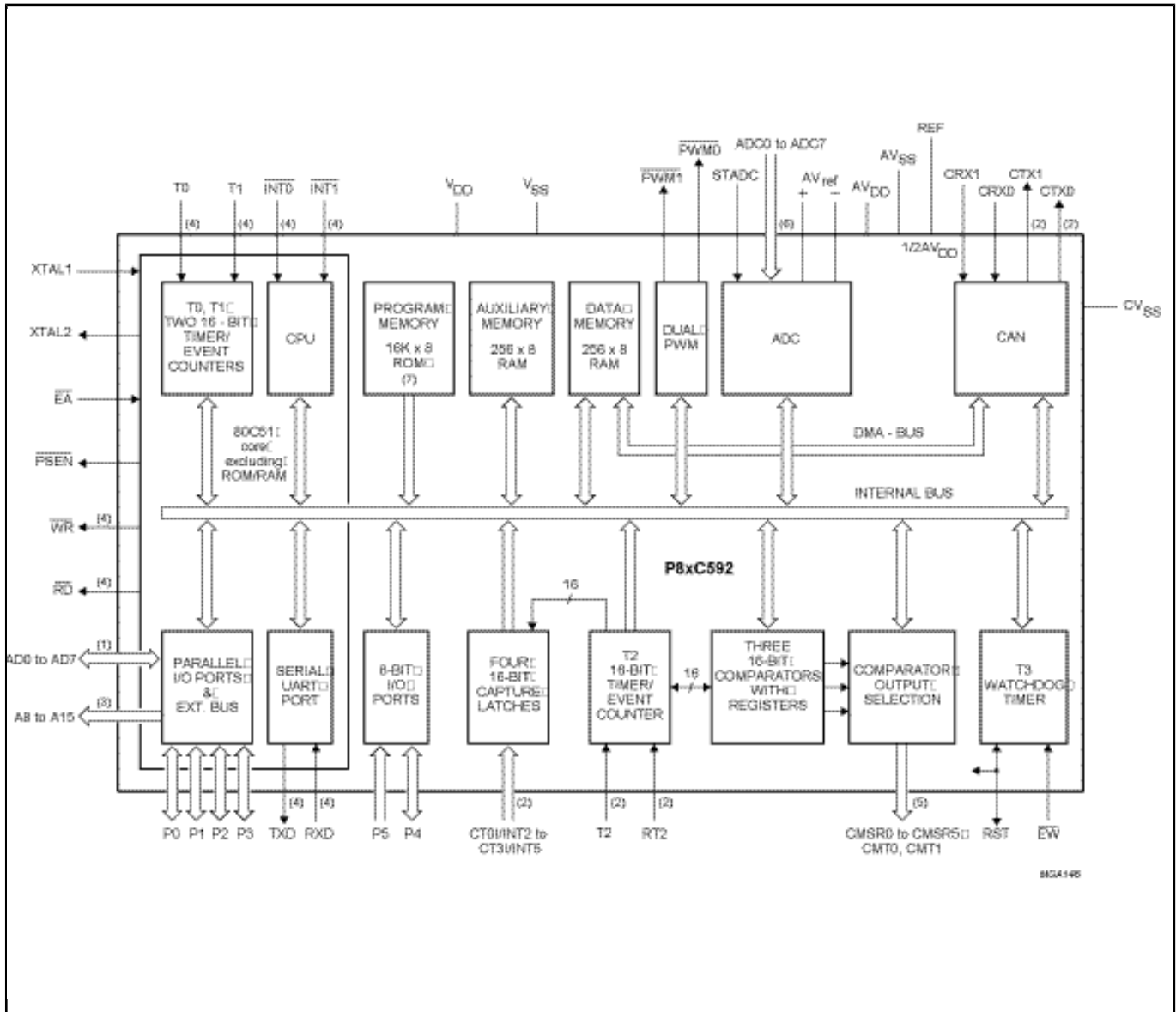

View additional information for [8-Bit Microcontroller with On-Chip CAN](#).

Note: The information on this document is subject to change without notice.

www.nxp.com

NXP and the NXP logo are trademarks of NXP B.V. All other product or service names are the property of their respective owners. The related technology may be protected by any or all of patents, copyrights, designs and trade secrets. All rights reserved. © 2024 NXP B.V.