



QorIQ® P1024/15 Single- and Dual-Core Communications Processors

P1024

新規採用非推奨

このページでは、新規設計を推奨しない製品に関する情報を掲載しています。

Last Updated: Oct 17, 2022

P1024 and P1015 devices are "Not recommended for new designs", please use the replacement families Power Architecture (T1013, T1023), Arm Architecture (LS1012, LS1023).

The QorIQ® P1 family, which includes the P1015 and P1024 communications processors, offers extensive integration and extreme power for a wide variety of applications in the networking, telecom, defense and industrial markets. Based on 45 nm technology for low-power implementation, the P1015 and P1024 processors provide single- and dual-core solutions for the 400 MHz to 667 MHz performance range, along with advanced security and a rich set of interfaces.

The QorIQ P1015 and P1024 processors are pin-compatible with the QorIQ P1016, P1025 products, and software-compatible with the P1011/P1020 and P2010/P2020 offering a six-chip range of cost-effective solutions. Scaling from a single core at 400 MHz (P1015) to a dual core at 1.2 GHz per core (P2020), the two QorIQ platforms deliver an impressive 4.5x aggregate frequency range.

Freescale QorIQ P1024/15 Communication Processor Block Diagram Block Diagram

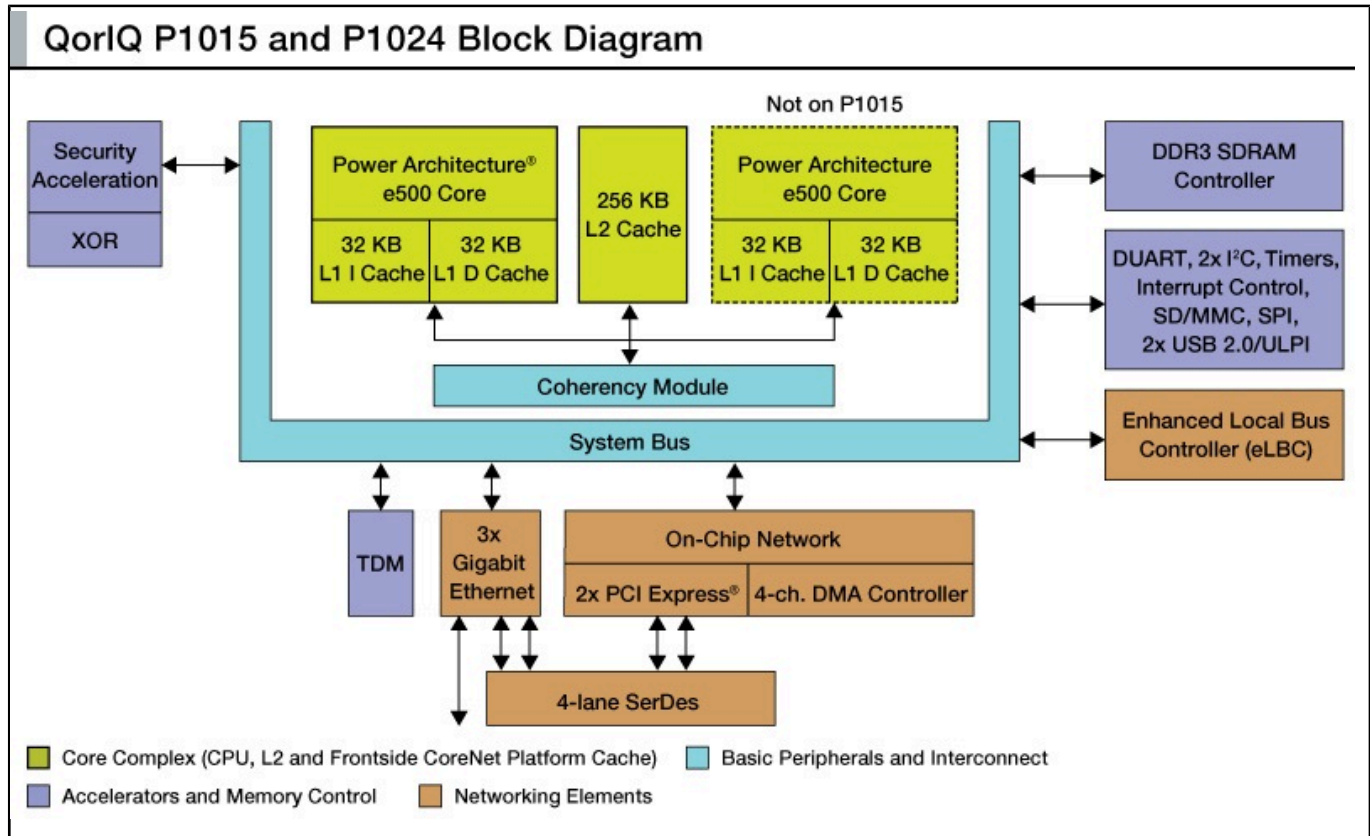

View additional information for [QorIQ® P1024/15 Single- and Dual-Core Communications Processors](#).

Note: The information on this document is subject to change without notice.

www.nxp.com

NXP and the NXP logo are trademarks of NXP B.V. All other product or service names are the property of their respective owners. The related technology may be protected by any or all of patents, copyrights, designs and trade secrets. All rights reserved. © 2024 NXP B.V.