



Triple Low-Ohmic Single-Pole Double-Throw Analog Switch

NX3L4053

Last Updated: Jan 31, 2024

The NX3L4053 is a triple low-ohmic single-pole double-throw analog switch, suitable for use as an analog or digital multiplexer/demultiplexer. Each switch has a digital select input (nS), two independent inputs/outputs (nY0 and nY1) and a common input/output (nZ). All three switches share an enable input (E). A digital enable pin E is common to all switches. When E is HIGH, the switches are turned off.

Schmitt trigger action at the digital inputs makes the circuit tolerant to slower input rise and fall times. Low threshold digital inputs allows this device to be driven by 1.8 V logic levels in 3.3 V applications without significant increase in supply current ICC. This makes it possible for the NX3L4053 to switch 4.3 V signals with a 1.8 V digital controller, eliminating the need for logic level translation. The NX3L4053 allows signals with amplitude up to VCC to be transmitted from nZ to nY0 or nY1; or from nY0 or nY1 to nZ. Its low ON resistance (0.5 Ω) and flatness (0.13 μV) ensures minimal attenuation and distortion of transmitted signals.

NX3L4053 Block Diagram Block Diagram

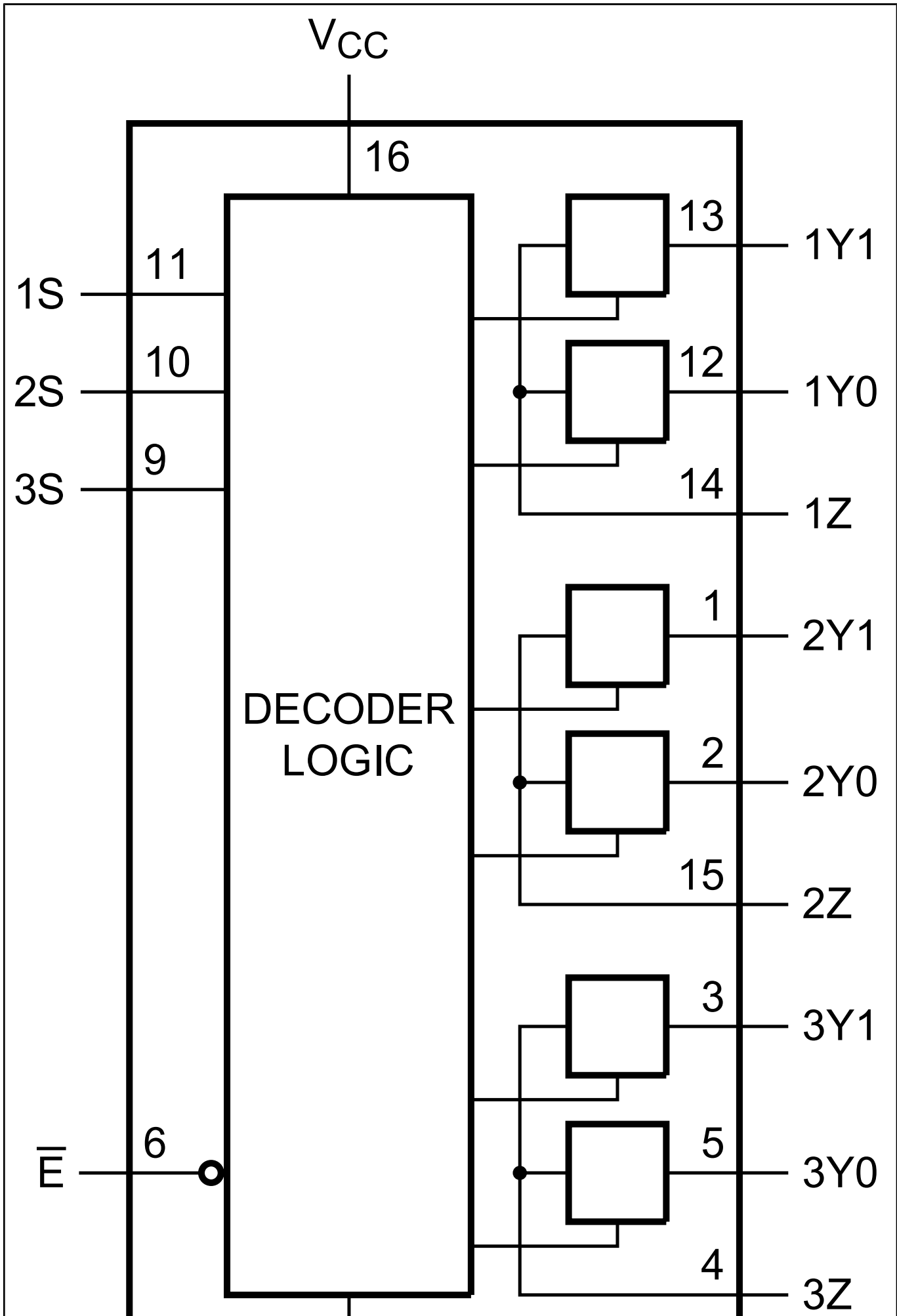

View additional information for [Triple Low-Ohmic Single-Pole Double-Throw Analog Switch](#).

Note: The information on this document is subject to change without notice.

www.nxp.com

NXP and the NXP logo are trademarks of NXP B.V. All other product or service names are the property of their respective owners. The related technology may be protected by any or all of patents, copyrights, designs and trade secrets. All rights reserved. © 2024 NXP B.V.