



Bidirectional Power Switch for Charger and USB-OTG Combinations

NX18P3001UK

アーカイブス

このページには、製造中止（生産終了）となった製品の情報が記載されています。本ページに記載されている仕様および情報は、過去の参考情報です。

Last Updated: Jul 13, 2023

The NX18P3001 is an advanced bidirectional power switch and ESD- protection device for combined USB-OTG and charger port applications. It includes undervoltage lockout, overvoltage lockout and overtemperature protection circuits designed to automatically isolate the power switch terminals when a fault condition occurs.

The device features two power switch input/output terminals (VBUSI and VBUSO), an open-drain acknowledge output (ACK), an enable input which includes logic level translation (EN) and low capacitance Transient Voltage Suppression (TVS) type ESD clamps for USB data and ID pins.

When EN is set HIGH the device enters a low-power mode, disabling all protection circuits. When used in combined charger and USB-OTG applications the 30 V tolerant VBUSI switch terminal is used as the supply and switch input when charging, for USB-OTG the VBUSO switch terminal is used as the supply and switch input.

Designed for operation from 3.2 V to 17.5 V, it is used in battery charging and power domain isolation applications to reduce power dissipation and extend battery life.

NX18P3001 Block Diagram Block Diagram

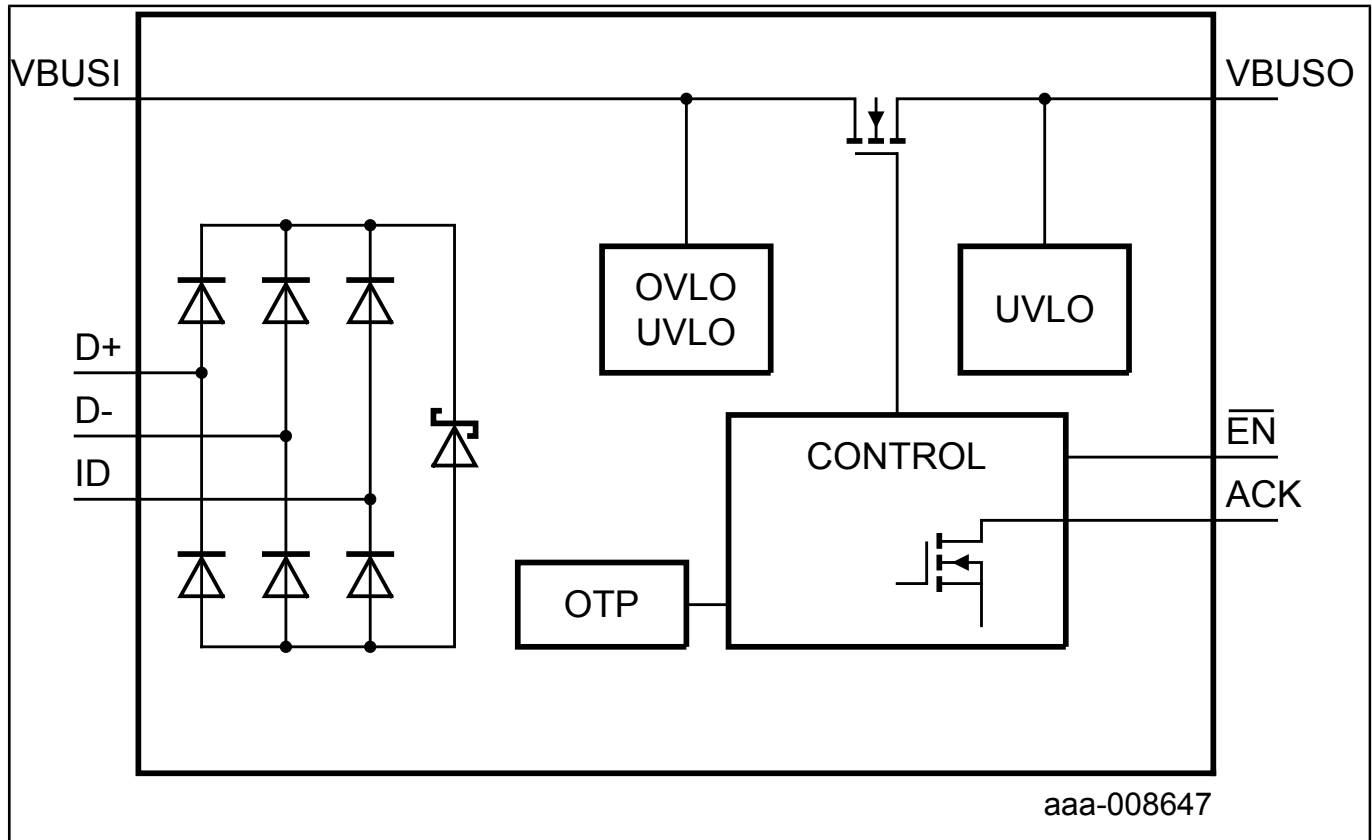

View additional information for [Bidirectional Power Switch for Charger and USB-OTG Combinations](#).

Note: The information on this document is subject to change without notice.

www.nxp.com

NXP and the NXP logo are trademarks of NXP B.V. All other product or service names are the property of their respective owners. The related technology may be protected by any or all of patents, copyrights, designs and trade secrets. All rights reserved. © 2024 NXP B.V.