



15 Watt Dual-device Wireless Power Controller for Auto Applications

MWCT1213A

Last Updated: Apr 9, 2022

The NXP® MWCT1213A multi-coil wireless charging transmitter IC provides complete controller functionality to implement a wireless charging transmitter controller in an automotive environment. System supports dual-channel transmitter control, and manage overall system state, such as FOD, temperature and system efficiency

- The NXP® MWCT1213A multi-coil wireless charging transmitter IC provides complete controller functionality to implement a wireless charging transmitter in an automotive environment. System supports one chip dual-channel transmitter control, and manage overall system state, such as FOD, temperature and system efficiency for both channels.
- Latest WPC Qi v1.2.4 certified and can be designed for v1.3 with authentication
 - Latest WPC Qi v1.2.4 support, new Qi v1.3 with authentication ready
- Supports Qi certified EPP 15W receiver, max power is 30W(15W x 2), system compatible with customized fast charge mode
 - Supports 2x Qi certified EPP 15W receiver, max power is 30W (15W x 2), system compatible with customized fast charge mode

MWCT1213 based solution Block Diagram Block Diagram

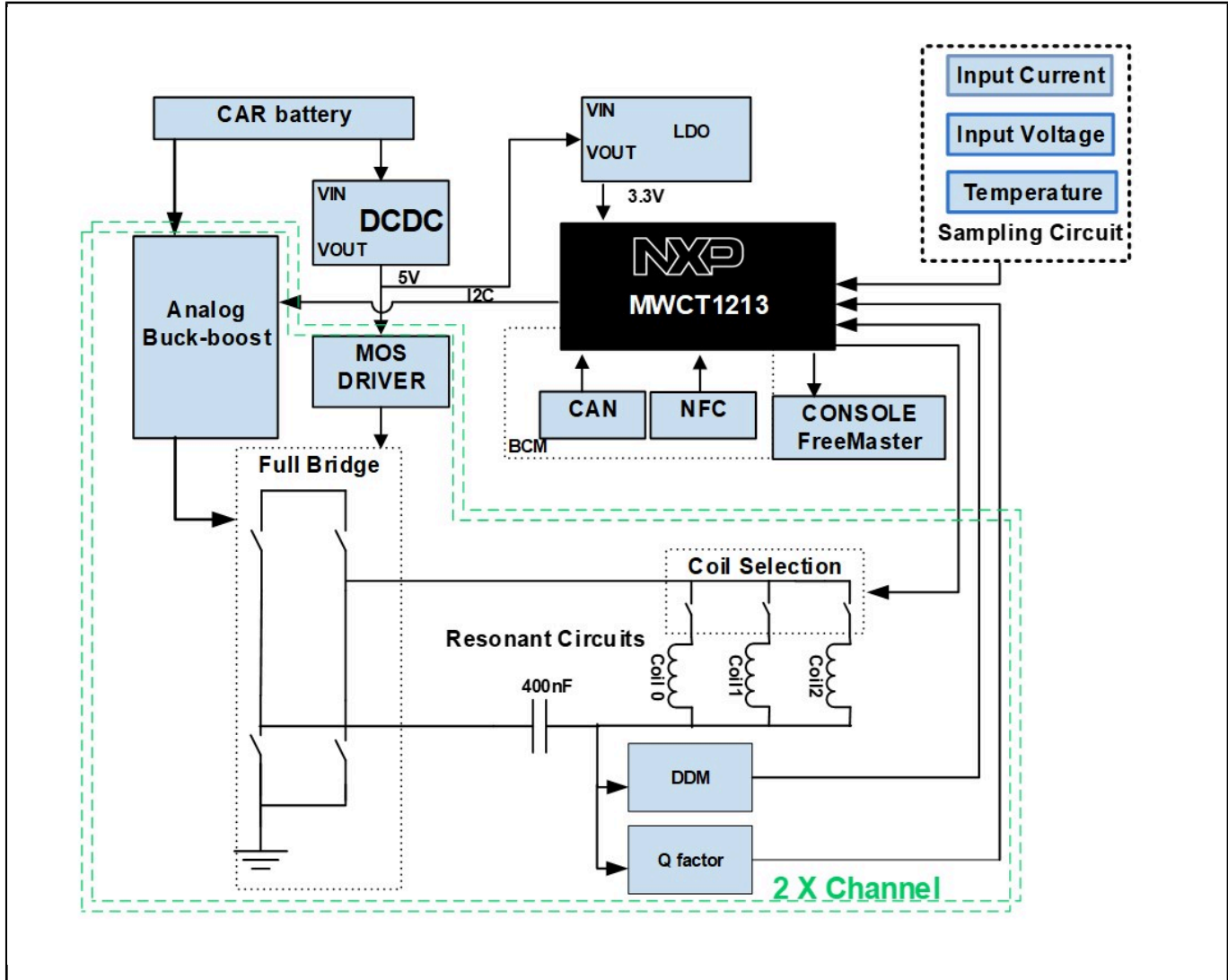

View additional information for [15 Watt Dual-device Wireless Power Controller for Auto Applications](#).

Note: The information on this document is subject to change without notice.

www.nxp.com

NXP and the NXP logo are trademarks of NXP B.V. All other product or service names are the property of their respective owners. The related technology may be protected by any or all of patents, copyrights, designs and trade secrets. All rights reserved. © 2024 NXP B.V.