



Absolute Digital Pressure Sensor (50 to 115 kPa)

MPL115A

Last Updated: May 17, 2024

The MPL115A1ST1 and MPL115A2ST1 are the recommend devices for new designs as the MPL115A1T1 and MPL115A2T1 are discontinued.

The MPL115A is a simple barometer with digital output for cost-effective applications. It employs a MEMS pressure sensor with a conditioning integrated circuit to provide accurate pressure data. An integrated analog-to-digital converter (ADC) provides digitized temperature and pressure sensor outputs via either a serial peripheral interface (SPI) (MPL115A1) or I²C (MPL115A2) port. Calibration data is housed in on-board ROM, is used by the host microcontroller to apply compensation algorithms to the raw sensor data and may be accessed at any time. Calibration data is typically accessed when the host micro first enables the sensor. The MPL115A1 operates as a SPI follower with bus speeds up to 8 Mbps. The MPL115A2 operates as a I²C target capable of bus speeds up to 400 Kbps (fast mode). Both versions are offered in a 5.0 mm x 3.0 mm x 1.2 mm max LGA package and are specified for operation from -40°C to 105°C. All packages are surface mount and RoHs compliant.

MPL115A Pressure Sensor Block Diagram Block Diagram

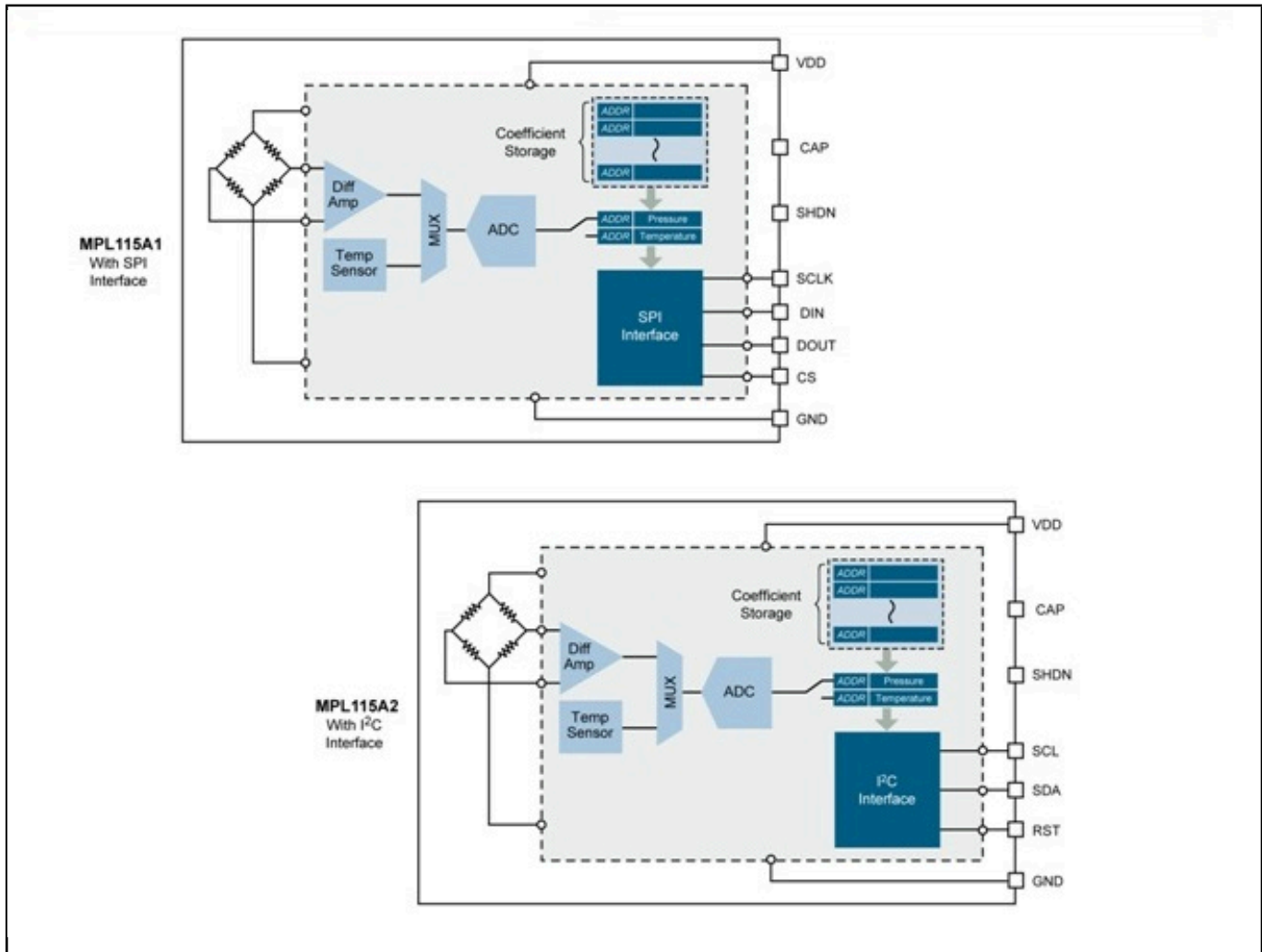

View additional information for [Absolute Digital Pressure Sensor \(50 to 115 kPa\)](#).

Note: The information on this document is subject to change without notice.

www.nxp.com

NXP and the NXP logo are trademarks of NXP B.V. All other product or service names are the property of their respective owners. The related technology may be protected by any or all of patents, copyrights, designs and trade secrets. All rights reserved. © 2024 NXP B.V.