



# MPC860 PowerQUICC® Processor

## MPC860

新規採用非推奨

このページでは、新規設計を推奨しない製品に関する情報を掲載しています。

Last Updated: Apr 8, 2022

The MPC860 PowerQUICC® offers an integrated processor and peripheral solution that can be used in a variety of communications and networking controller applications.

- Delivers higher performance in all areas of device operation including flexibility, extensions in capability, and integration
- Provides lower power consumption than traditional architectures
- Backed by strong third-party tool support through Our Design Alliance Program

# MPC860\_BLKDIAG Block Diagram

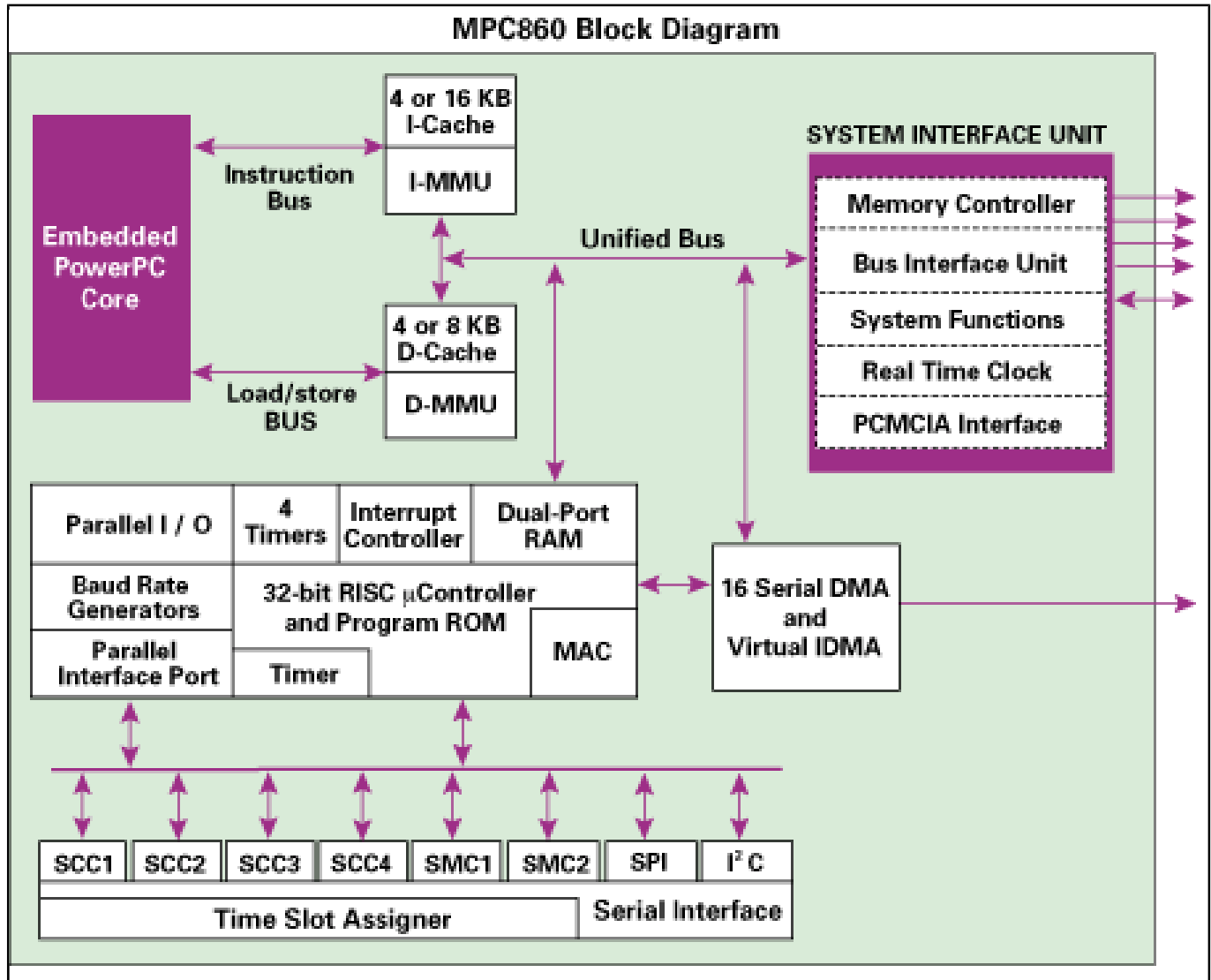

View additional information for [MPC860 PowerQUICC® Processor](#).

Note: The information on this document is subject to change without notice.

[www.nxp.com](http://www.nxp.com)

NXP and the NXP logo are trademarks of NXP B.V. All other product or service names are the property of their respective owners. The related technology may be protected by any or all of patents, copyrights, designs and trade secrets. All rights reserved. © 2024 NXP B.V.