



Ultra-Reliable MPC560xS MCU for Automotive and Industrial Instrument Clusters

MPC560xS

Last Updated: Apr 27, 2023

The NXP MPC560xS family of microcontrollers addresses color thin-film transistor (TFT) displays in automotive instrument cluster applications.

- Provides a cost-effective, mid-level instrument cluster solution
- Offers scalable features to fit specific performance needs
- Low-power design enables dynamic power management of core and peripherals
- Comprehensive development and software support help accelerate time-to-market

MPC560XS Microcontroller Block Diagram

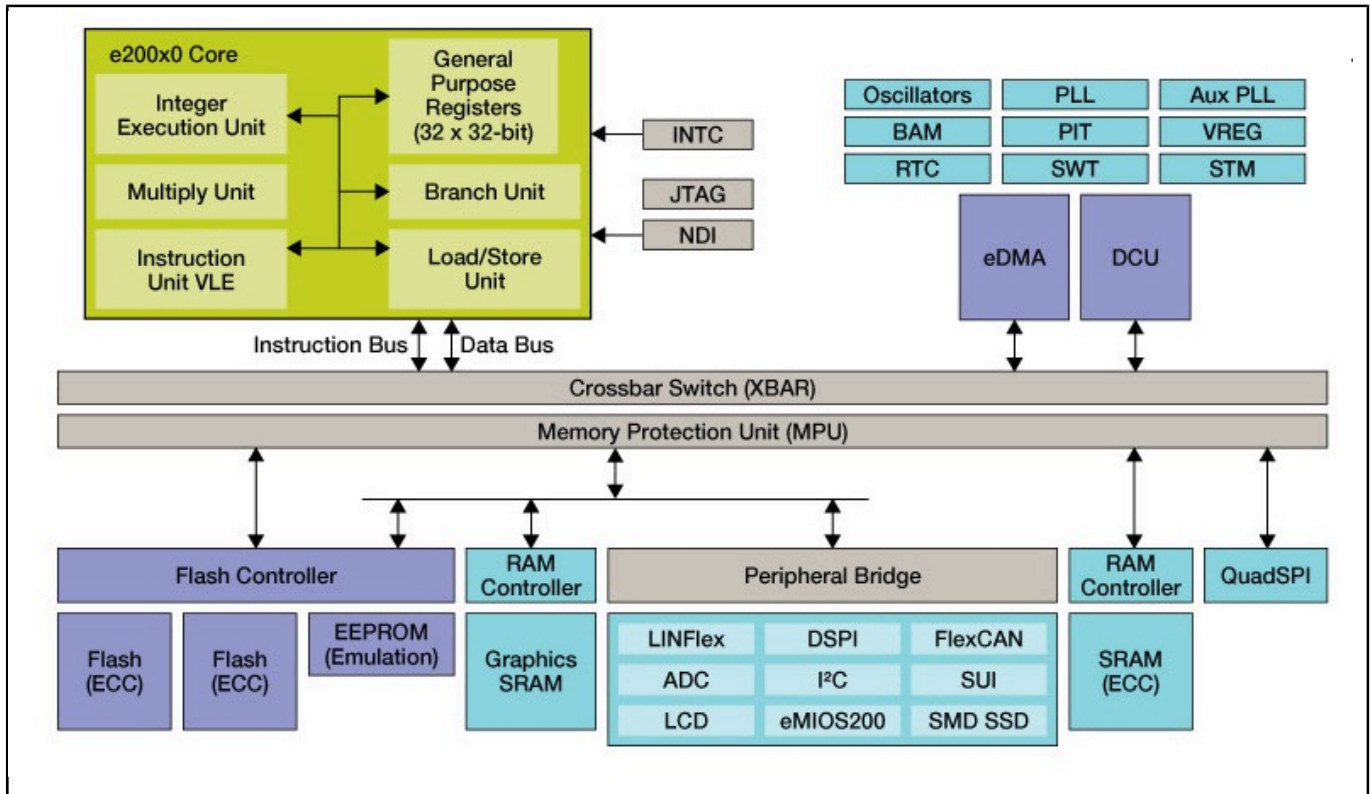

View additional information for [Ultra-Reliable MPC560xS MCU for Automotive and Industrial Instrument Clusters](#).

Note: The information on this document is subject to change without notice.

www.nxp.com

NXP and the NXP logo are trademarks of NXP B.V. All other product or service names are the property of their respective owners. The related technology may be protected by any or all of patents, copyrights, designs and trade secrets. All rights reserved. © 2024 NXP B.V.