



Dual H-Bridge, Motor Driver, 2-8.6 V, 1.4 A, 200 kHz

MPC17531

アーカイブス

このページには、製造中止（生産終了）となった製品の情報が記載されています。本ページに記載されている仕様および情報は、過去の参考情報です。

Last Updated: Jul 26, 2023

The NXP® MPC17531A is a monolithic dual H-Bridge power IC ideal for portable electronic applications containing bipolar step motors and/or brush DC-motors, such as cameras and disk drive head positioners.

- Operates from 2.0 V to 8.6 V using the internal charge pump, with independent control of each H-Bridge via parallel MCU interface
- Features built-in shoot-through current protection and an undervoltage shutdown function
- Has four operating modes: Forward, Reverse, Brake, and Tri-States (High Impedance)
- Efficiently drives many types of micromotors with low power dissipation owing to its low output resistance and high output slew rates

MPC17531 Block Diagram

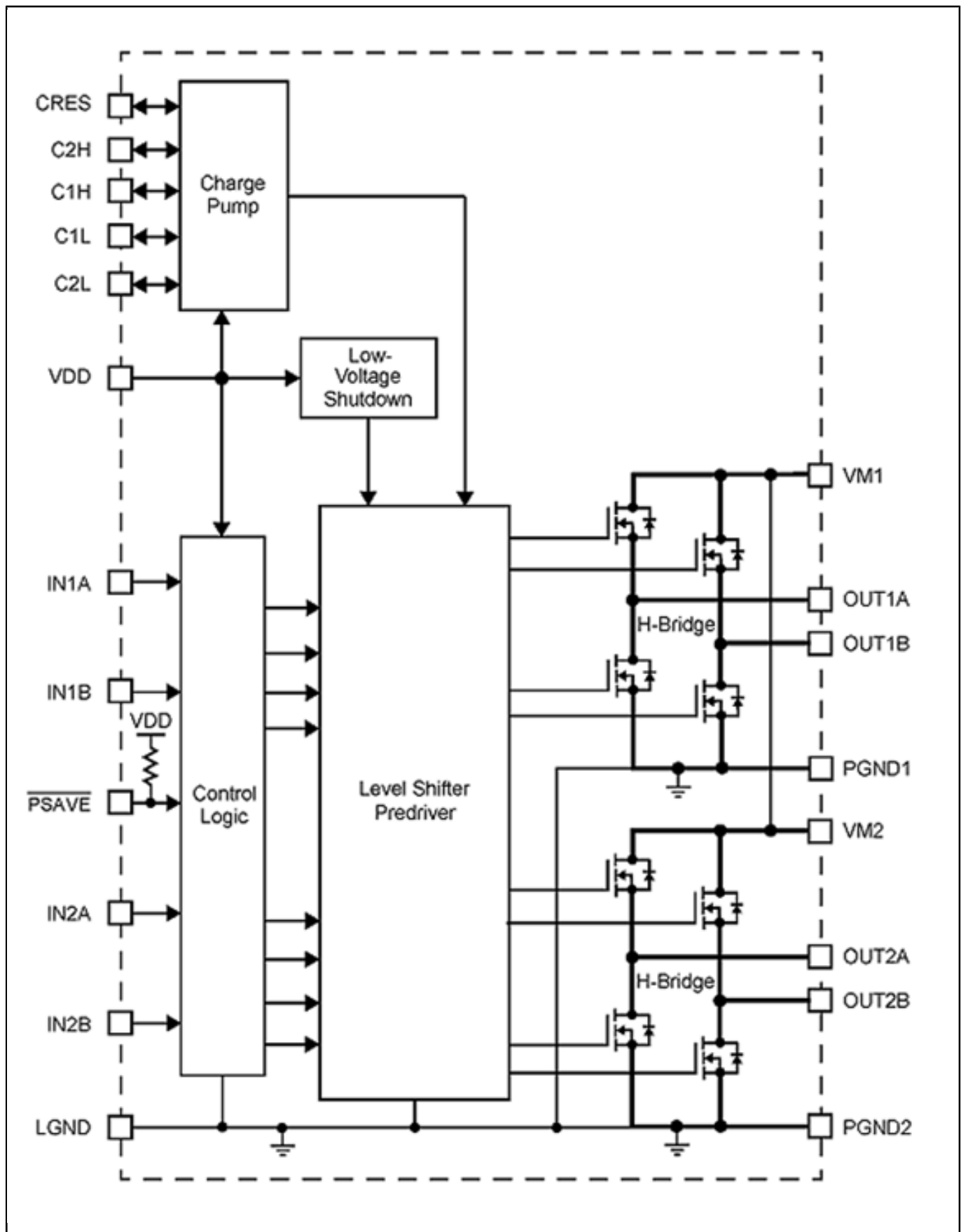

View additional information for [Dual H-Bridge, Motor Driver, 2-8.6 V, 1.4 A, 200 kHz](#).

Note: The information on this document is subject to change without notice.

www.nxp.com

NXP and the NXP logo are trademarks of NXP B.V. All other product or service names are the property of their respective owners. The related technology may be protected by any or all of patents, copyrights, designs and trade secrets. All rights reserved. © 2024 NXP B.V.