



DSI2.5 $\pm 25g$ to $\pm 375g$ X-Axis, Medium- or High-g, Digital Inertial Sensor

MMA26xx

新規採用非推奨

このページでは、新規設計を推奨しない製品に関する情報を掲載しています。

Last Updated: Sep 26, 2023

The MMA26xxW and MMA26xxNWR2 inertial satellite sensors support the DSI communication protocol for front and side crash detection in automotive applications.

- Offers the only supplier with an x-axis over-damped inertial satellite sensor housed in a QFN package
- Enables a smaller footprint and more flexibility for module orientation in vehicles
- Provides SafeAssure functional safety

MMA16xx Acceleration Sensor Block Diagram Block Diagram

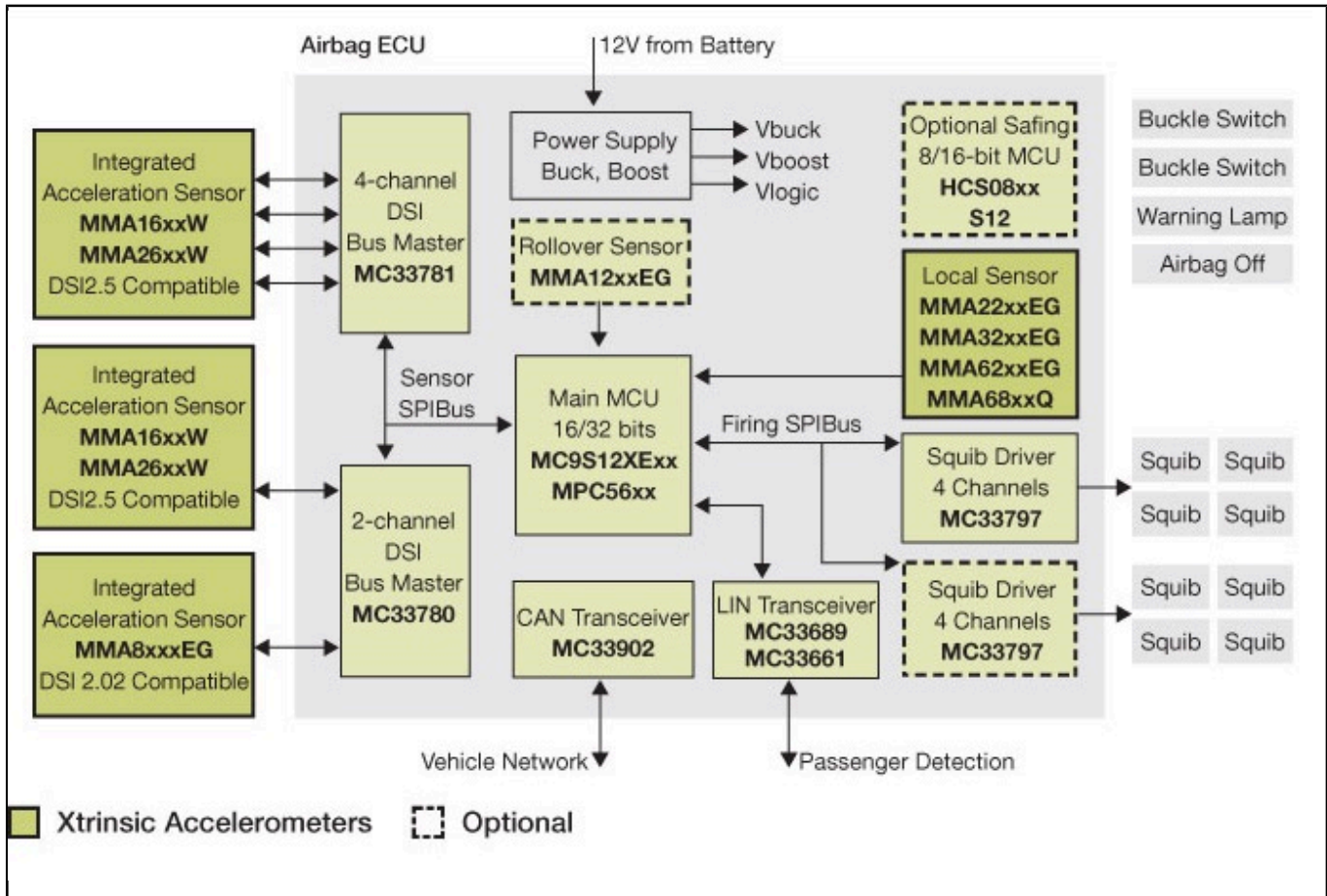

View additional information for [DSI2.5 ±25g to ±375g X-Axis, Medium- or High-g, Digital Inertial Sensor](#).

Note: The information on this document is subject to change without notice.

www.nxp.com

NXP and the NXP logo are trademarks of NXP B.V. All other product or service names are the property of their respective owners. The related technology may be protected by any or all of patents, copyrights, designs and trade secrets. All rights reserved. © 2024 NXP B.V.